



US00D372686S

United States Patent [19]

[11] Patent Number: **Des. 372,686**

Hattori et al.

[45] Date of Patent: ****Aug. 13, 1996**

[54] PASSENGER CAR

D. 318,828 8/1991 Wada et al. D12/91
D. 358,118 5/1995 Lee et al. D12/91

[75] Inventors: **Moriyoshi Hattori; Yutaka Yamamoto**, both of Shizuoka-ken, Japan

FOREIGN PATENT DOCUMENTS

731787 of 1988 Japan .
844006 of 1992 Japan .

[73] Assignee: **Suzuki Motor Corporation**, Shizuoka-ken, Japan

Primary Examiner—Brian N. Vinson
Attorney, Agent, or Firm—Kinney & Lange, P.A.

[**] Term: **14 Years**

[57] CLAIM

[21] Appl. No.: **32,570**

The ornamental design for a passenger car, as shown and described.

[22] Filed: **Dec. 21, 1994**

DESCRIPTION

[30] Foreign Application Priority Data

Jun. 24, 1994 [JP] Japan 6-18814
[52] U.S. Cl. **D12/91**
[58] Field of Search D12/82, 86-87,
D12/93; 296/185

FIG. 1 is a front elevational view;
FIG. 2 is a rear elevational view;
FIG. 3 is a top plan view;
FIG. 4 is a bottom plan view;
FIG. 5 is a right side view;
FIG. 6 is a left side view;
FIG. 7 is a front perspective view; and,
FIG. 8 is a rear perspective view.

[56] References Cited

U.S. PATENT DOCUMENTS

D. 296,537 7/1988 Kim D12/91
D. 318,827 8/1991 Wada et al. D12/91

1 Claim, 7 Drawing Sheets

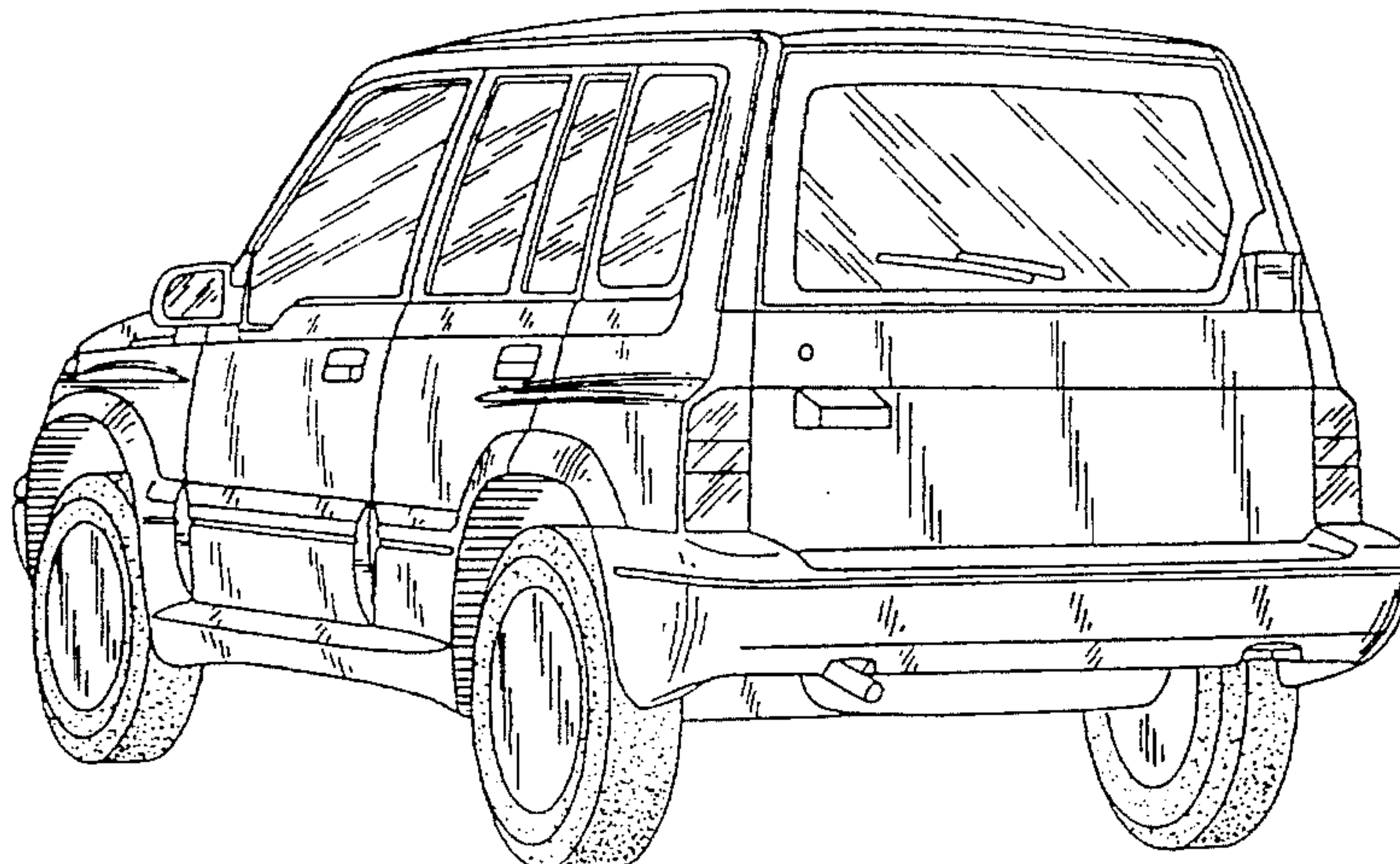
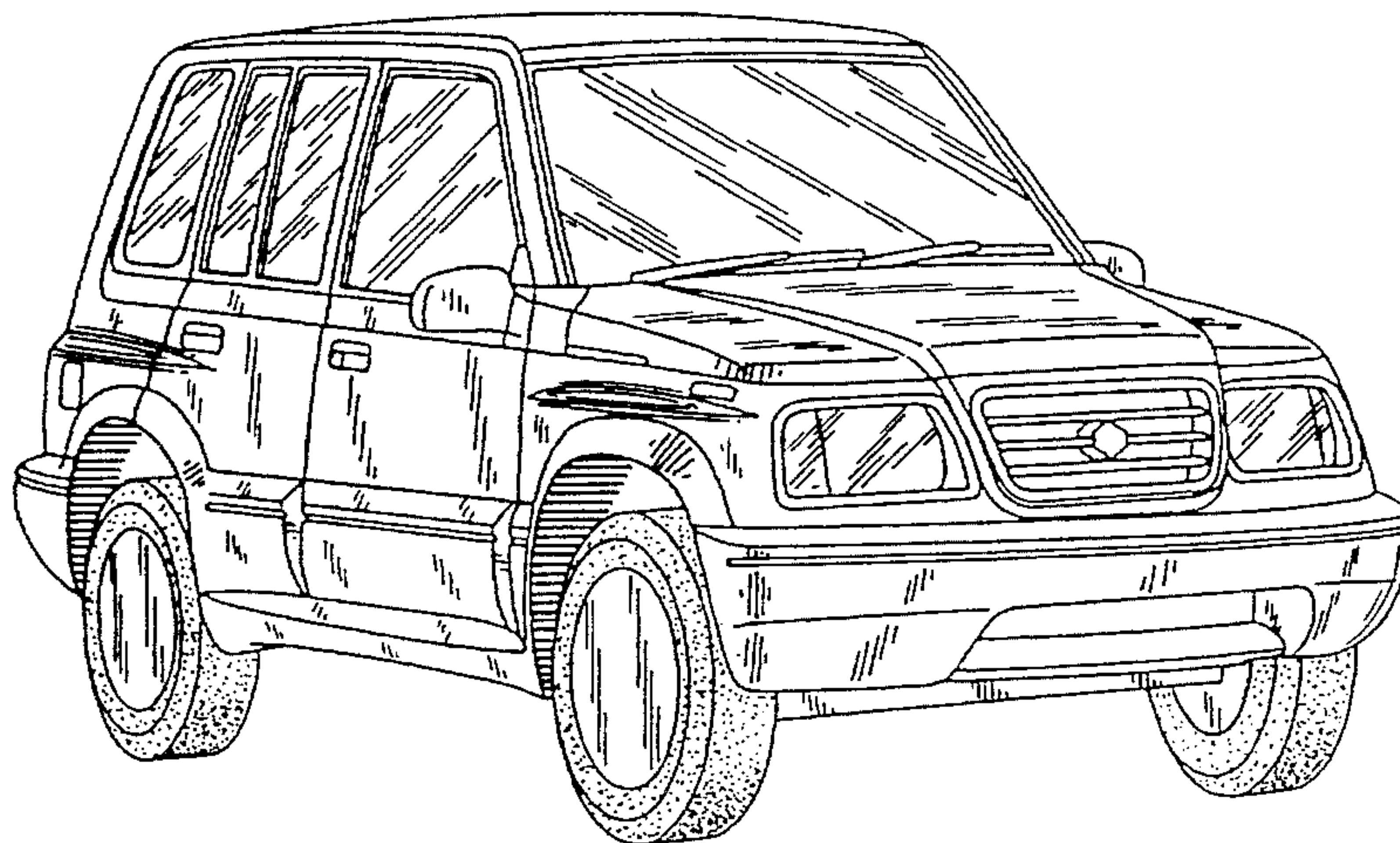

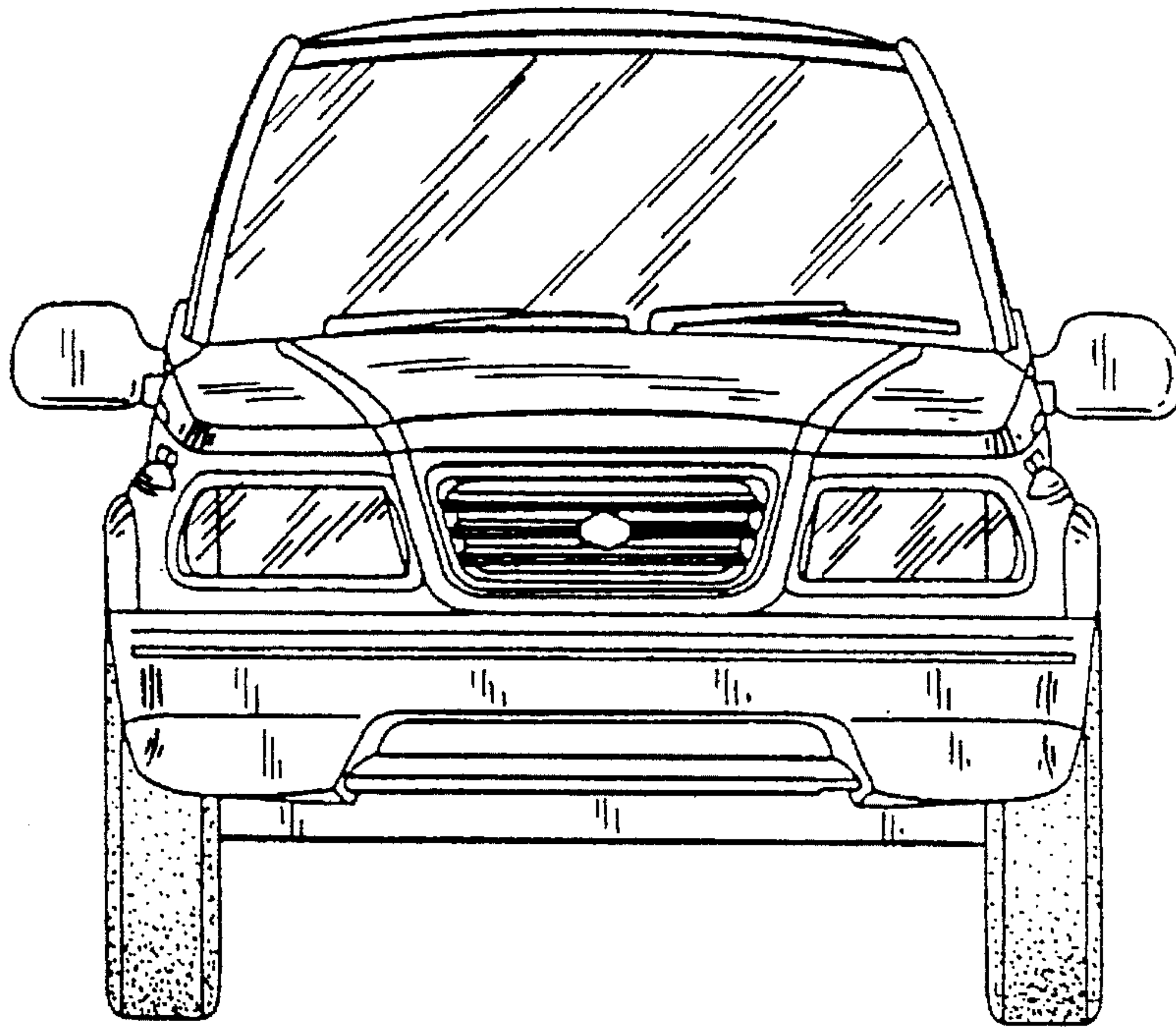

Fig. 1

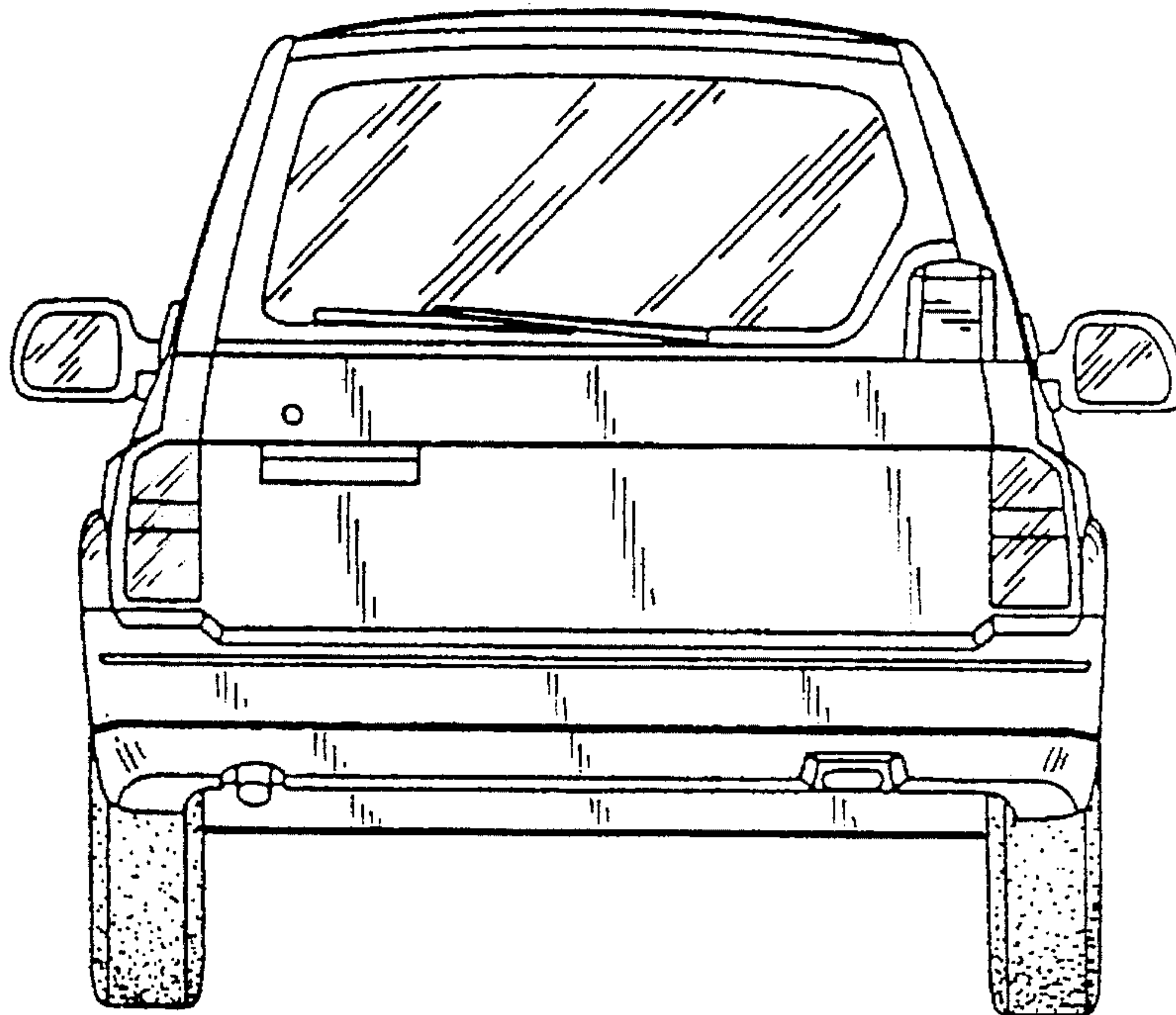

Fig. 2

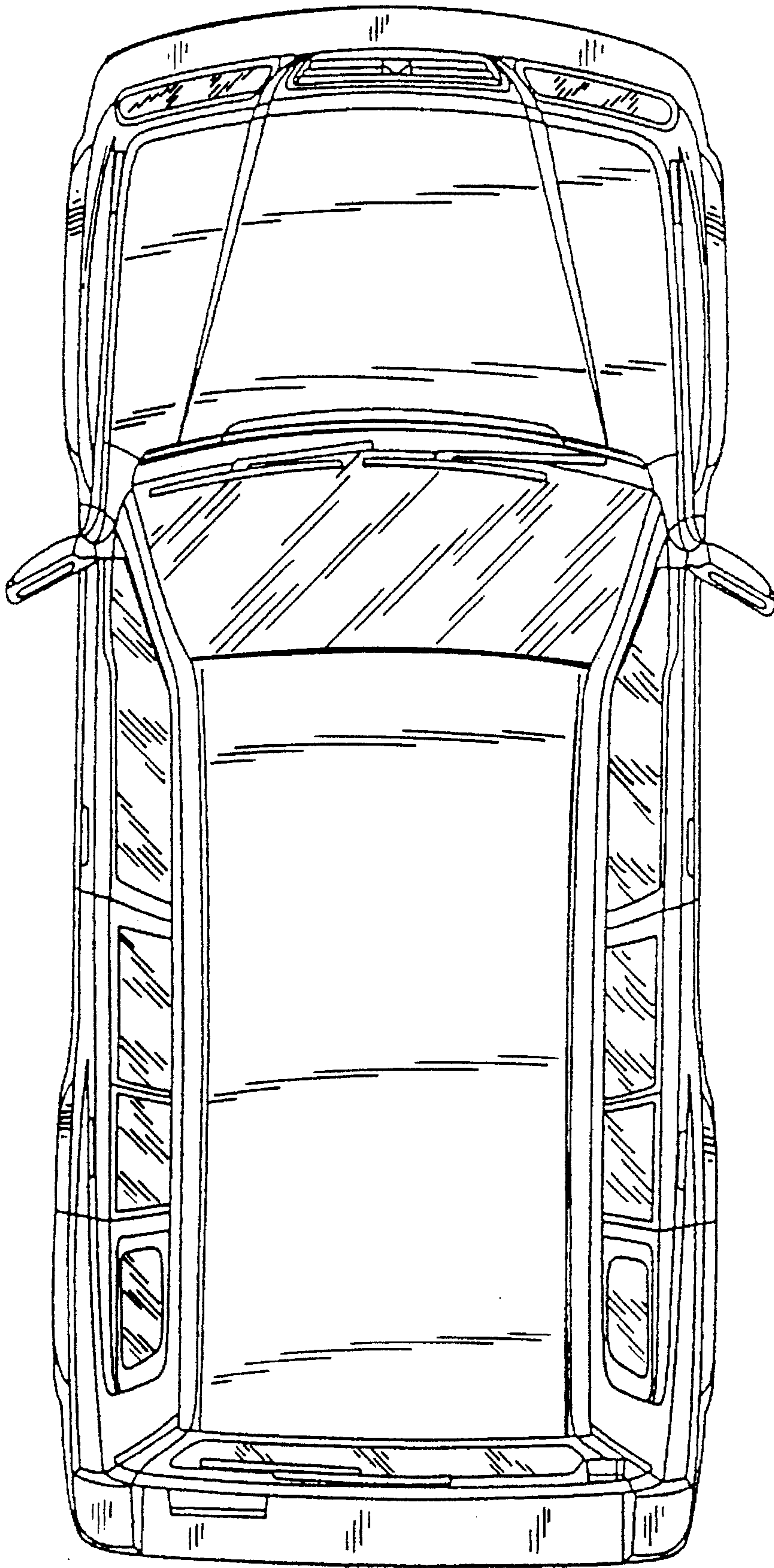

Fig. 3

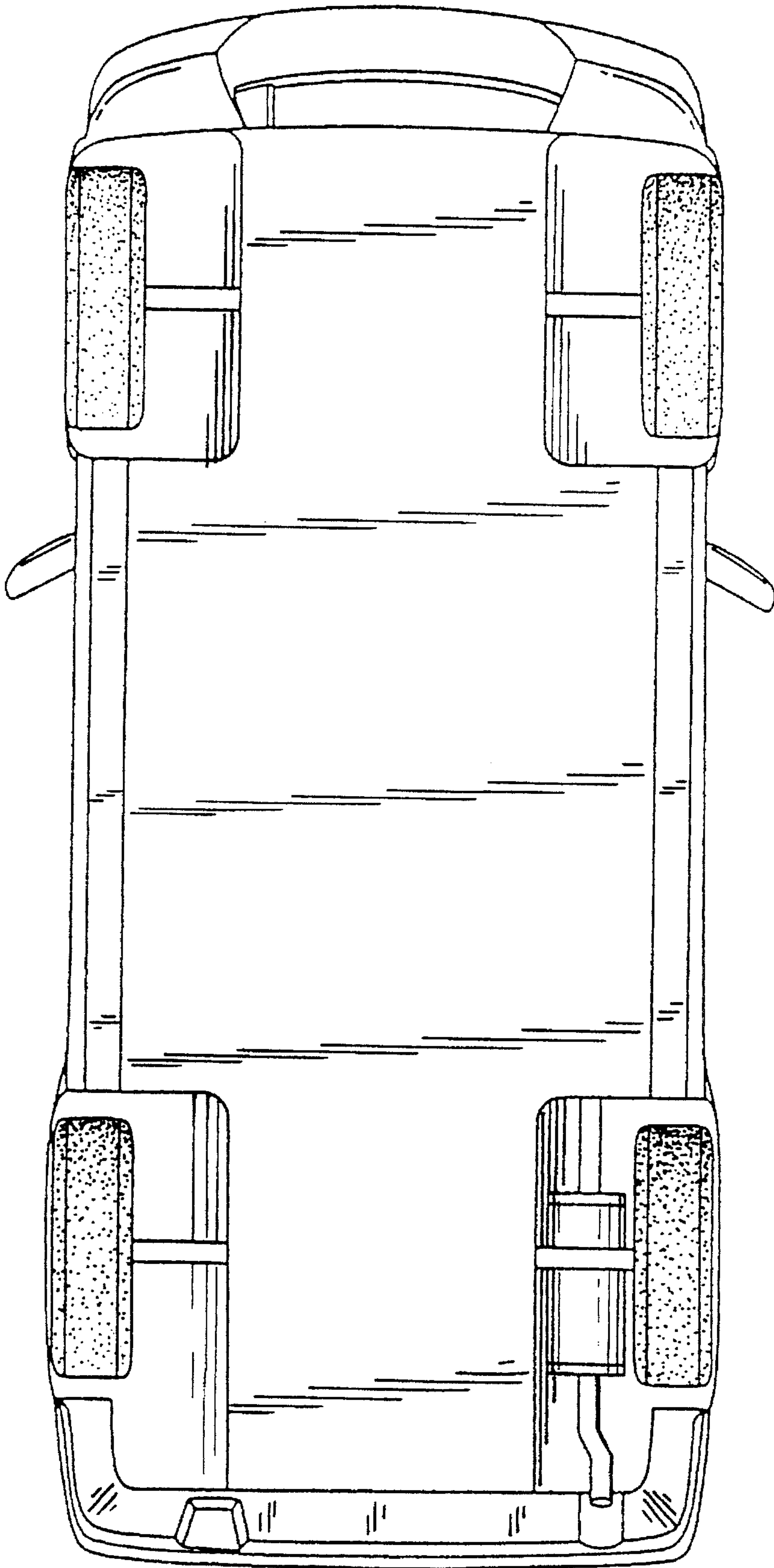

Fig. 4

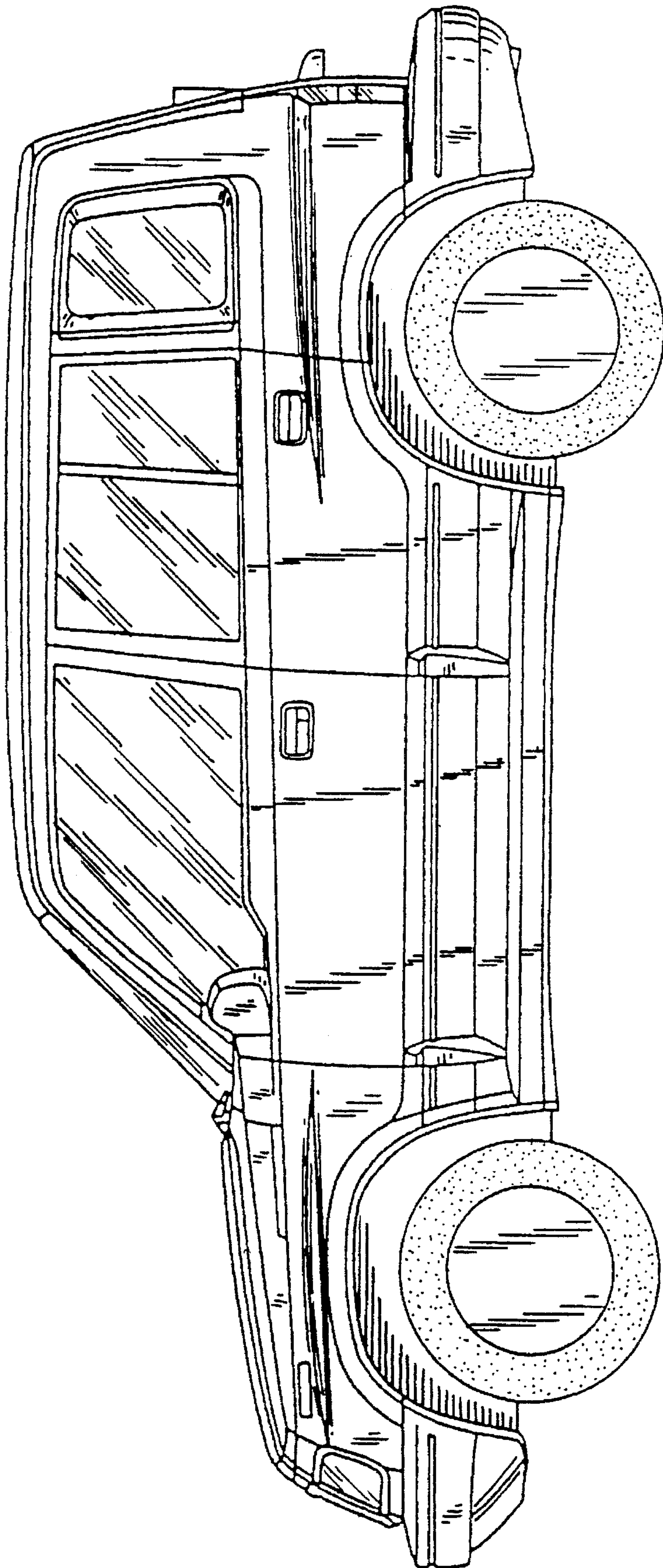

Fig. 5

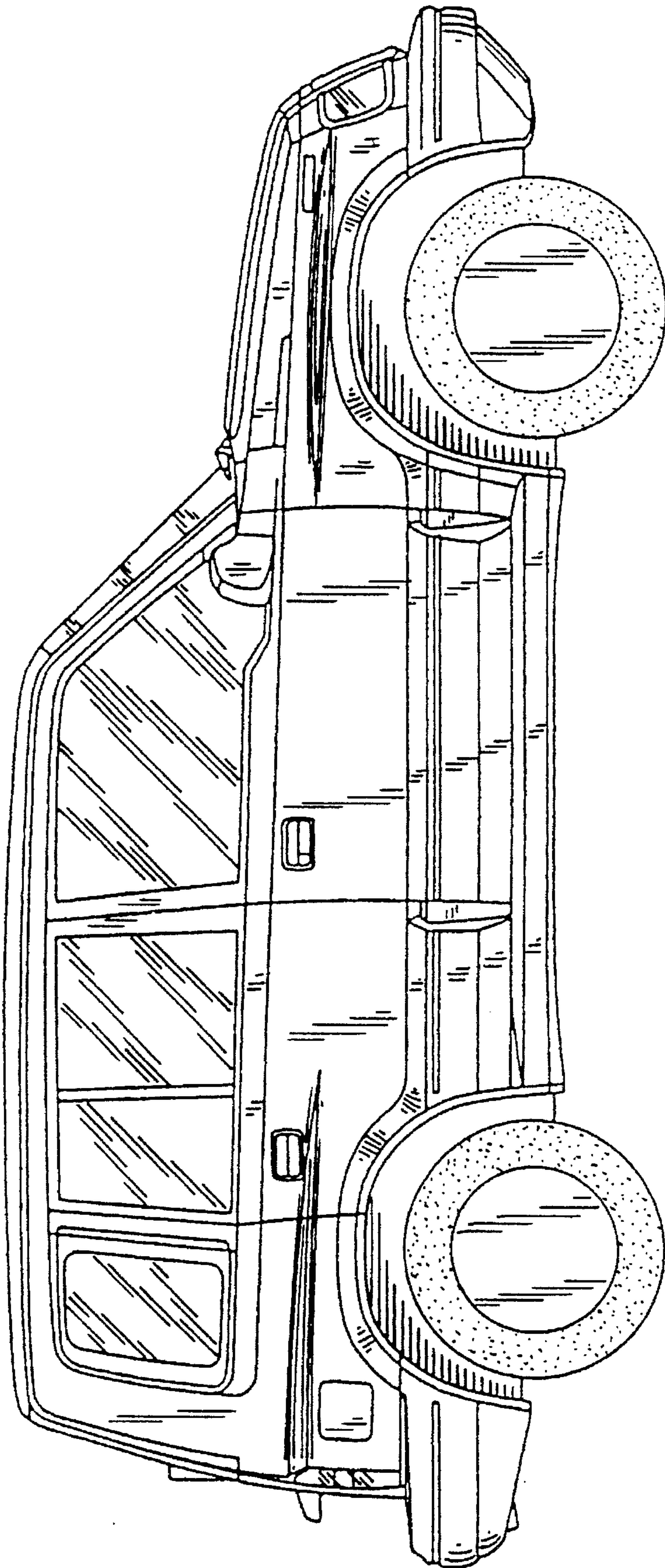

Fig. 6

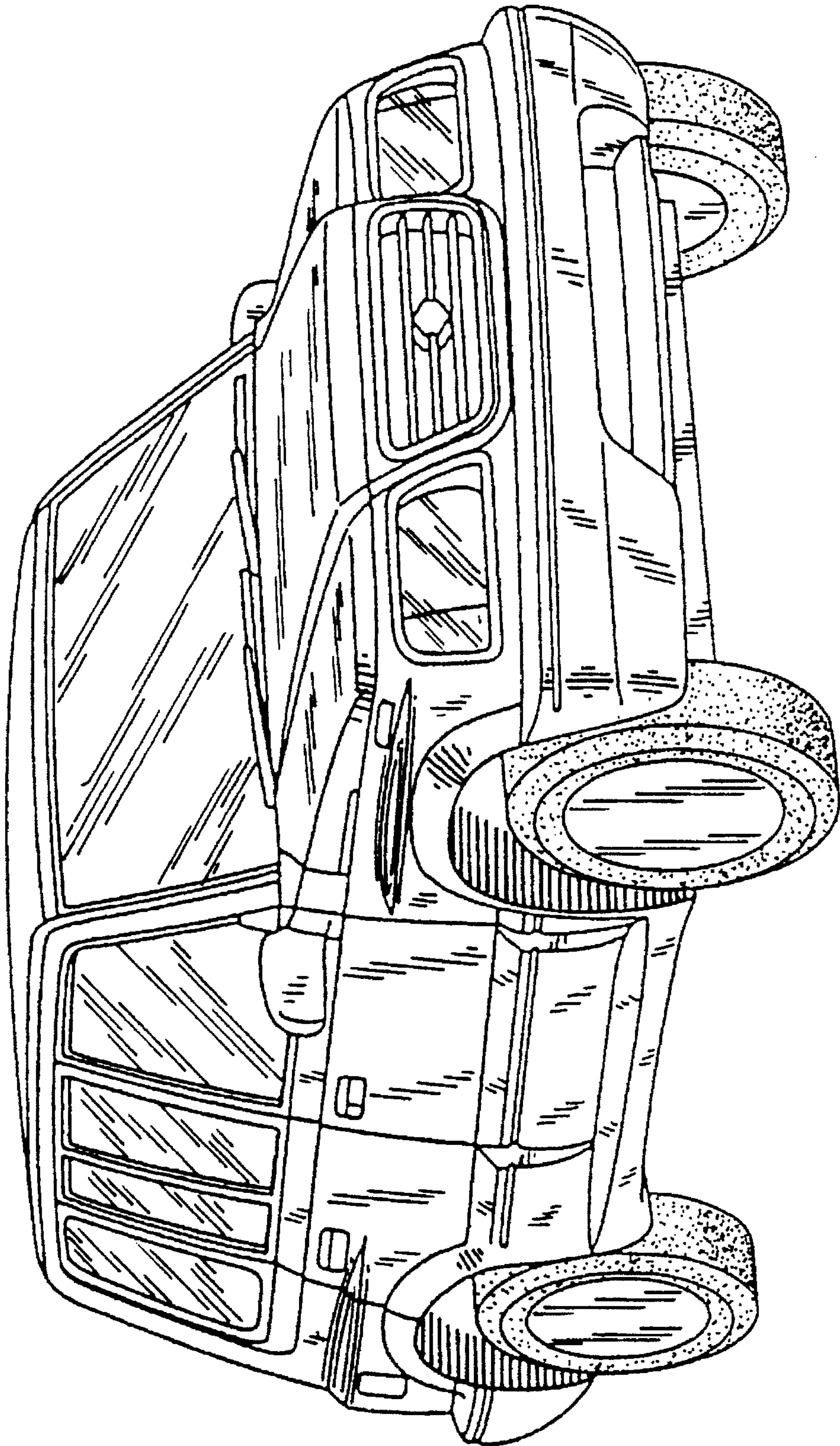

Fig. 7

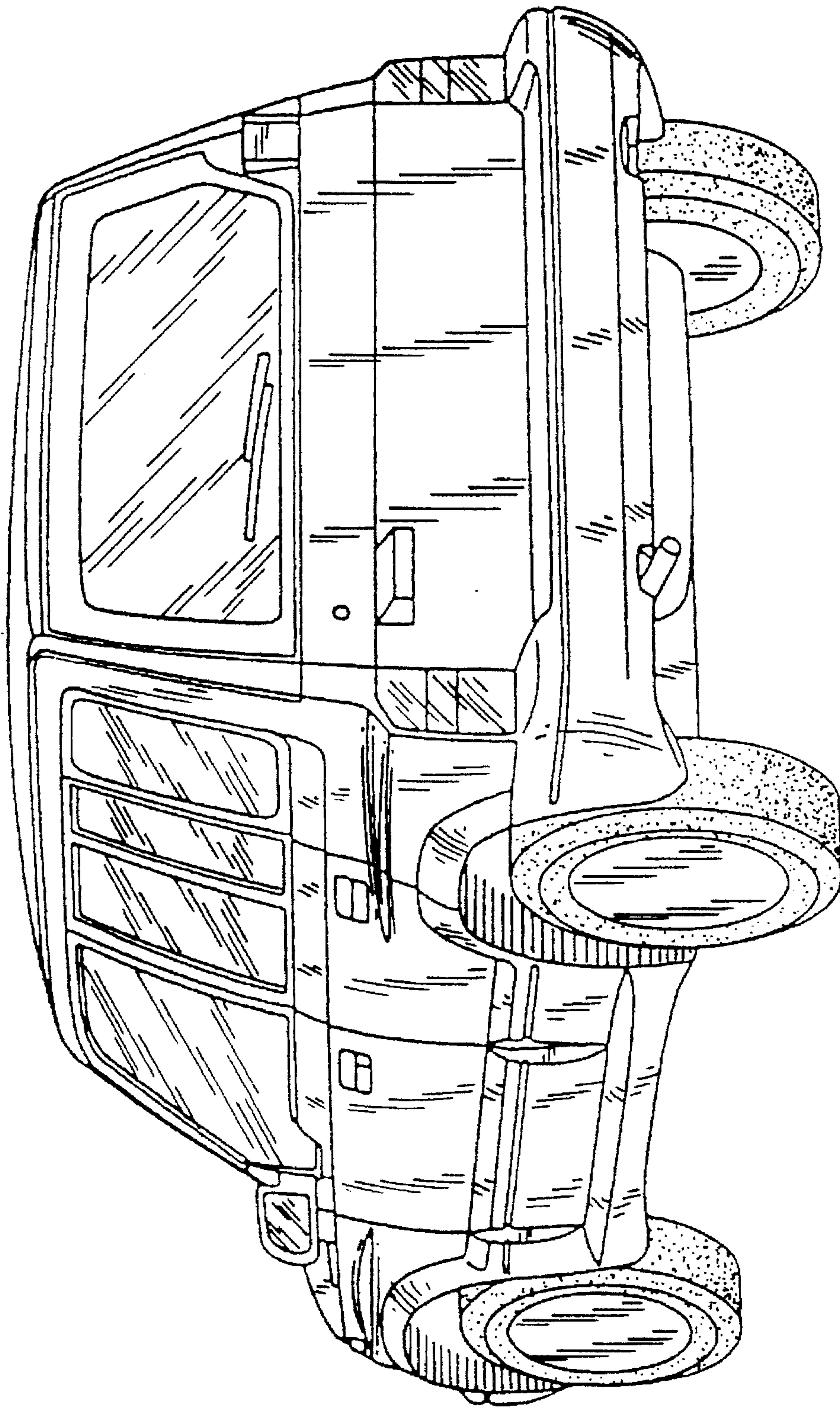

Fig. 8