



US00D372515S

United States Patent [19] Douglas

[11] Patent Number: **Des. 372,515**

[45] Date of Patent: ****Aug. 6, 1996**

[54] **WATER PURIFICATION UNIT**

[75] Inventor: **John H. Douglas**, Clearwater, Fla.

[73] Assignee: **Paragon Water Systems**, Clearwater, Fla.

[**] Term: **14 Years**

[21] Appl. No.: **34,585**

[22] Filed: **Feb. 8, 1995**

[52] U.S. Cl. **D23/209**

[58] **Field of Search** D23/207, 208, D23/209, 210, 200; 202/81, 82, 83, 160, 176, 181, 185.3, 185.5, 206, 234, 239, 97; 210/153, 162, 163, 172, 190-1, 198.1, 198.3, 244, 232, 245, 246, 435, 257.1, 448, 460, 282, 130, 348, 266, 449

2,466,999 4/1949 Rohland 210/438
 3,802,563 4/1974 Sasaki et al. 210/120
 5,308,478 5/1994 Harty 210/435 X

FOREIGN PATENT DOCUMENTS

404094708 3/1992 Japan 210/435

Primary Examiner—Joel Sincavage
Assistant Examiner—Cynthia E. Ramirez
Attorney, Agent, or Firm—M. K. Silverman

[57] CLAIM

The ornamental design for a water purification unit, as shown and described.

DESCRIPTION

FIG. 1 is a perspective view of my design for a water purification unit;
 FIG. 2 is a rear view thereof;
 FIG. 3 is a front view thereof;
 FIG. 4 is a right side view of which the left side view is a mirror image thereof;
 FIG. 5 is a bottom view; and,
 FIG. 6 is a top view of the inventive design.
 The valve in FIGS. 5 and 6 is shown in an alternate position.

[56] References Cited

U.S. PATENT DOCUMENTS

D. 227,886 7/1973 Martinez D23/209
 D. 228,065 8/1973 Comroe D23/207
 D. 304,363 10/1989 Ruesch D23/209
 D. 307,933 5/1990 Baer D23/209
 D. 318,093 7/1991 Ferguson D23/209
 D. 347,462 5/1994 Douglas D23/209

1 Claim, 2 Drawing Sheets

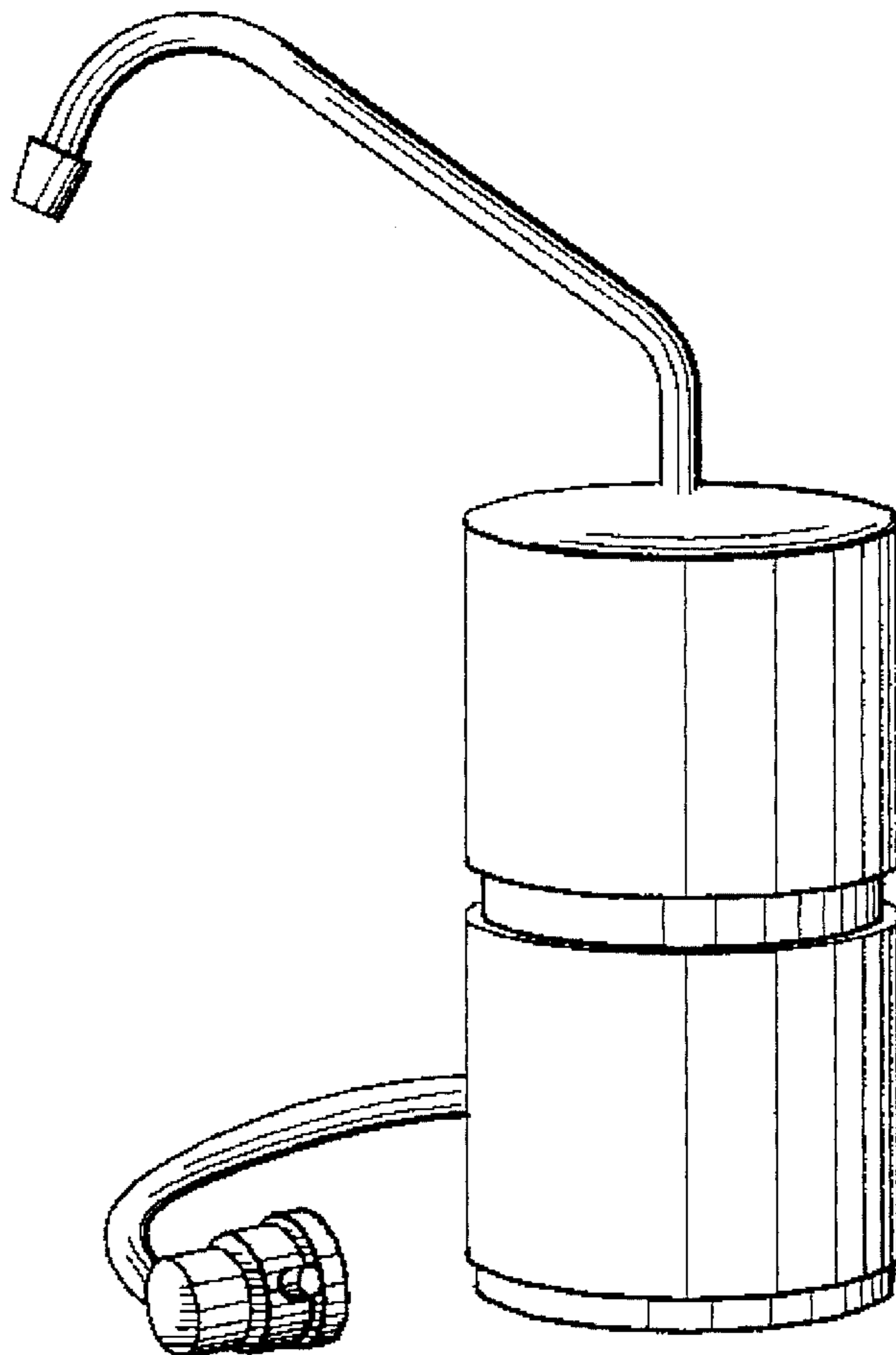

FIG. 1.

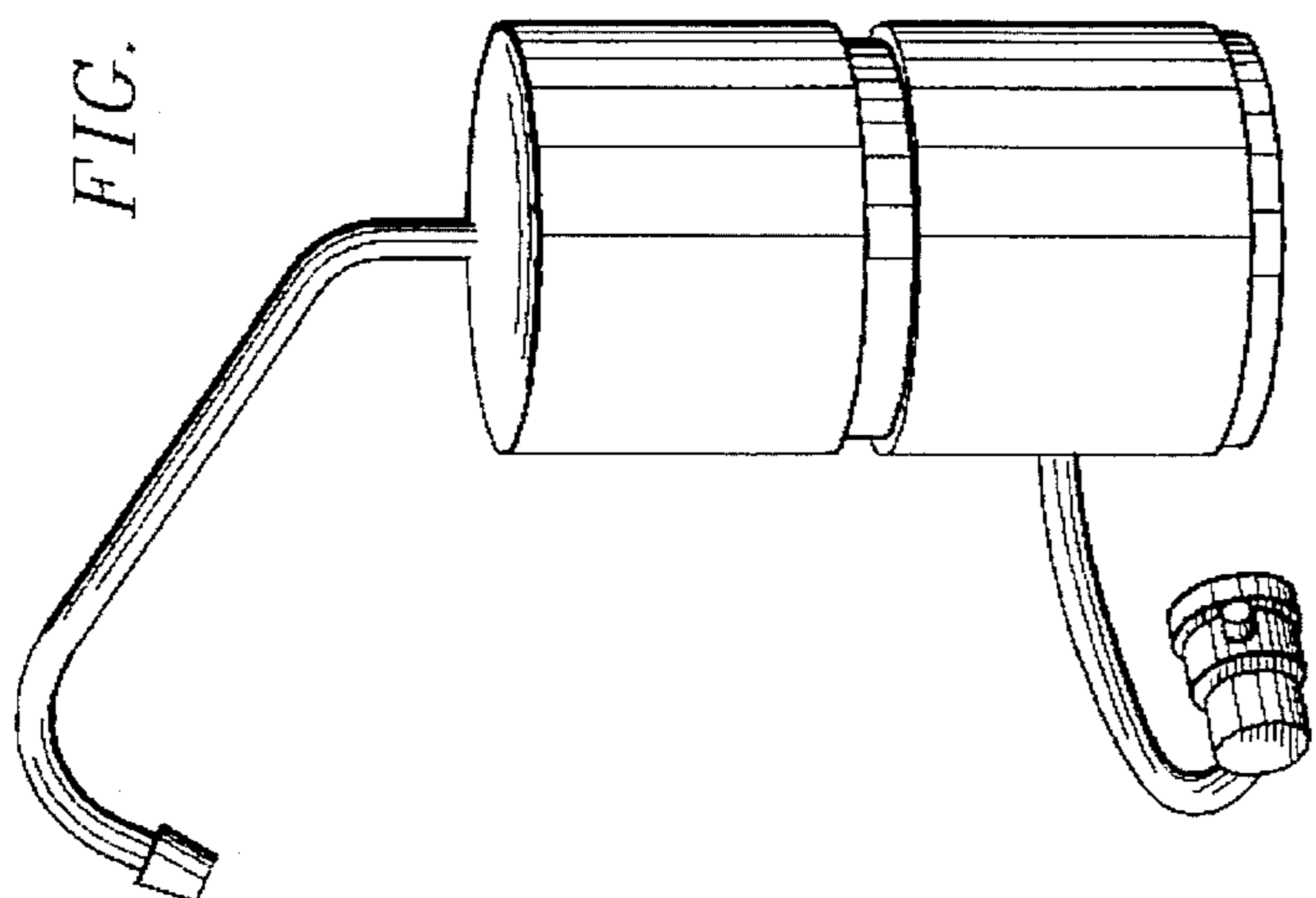

FIG. 3.

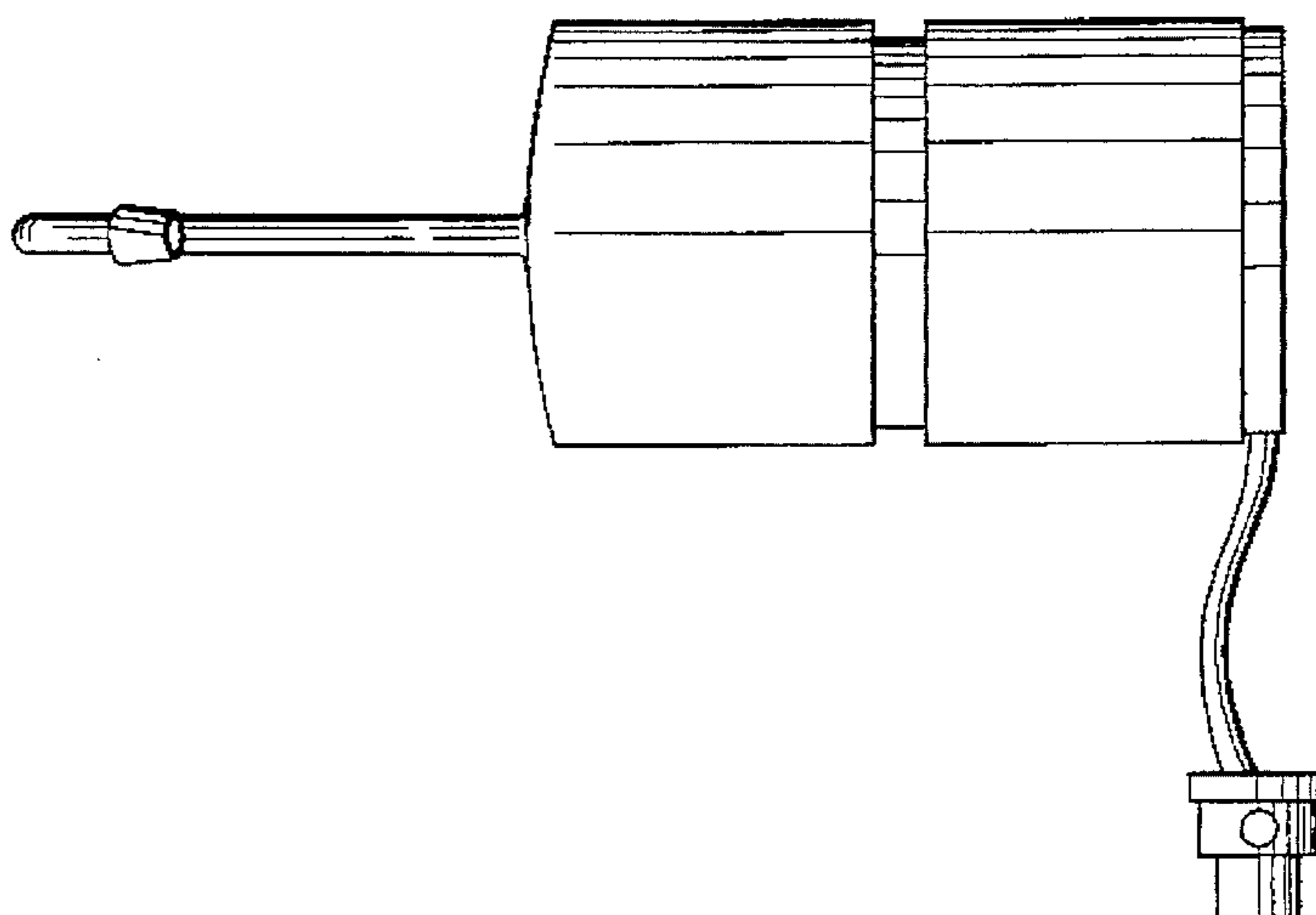

FIG. 2.

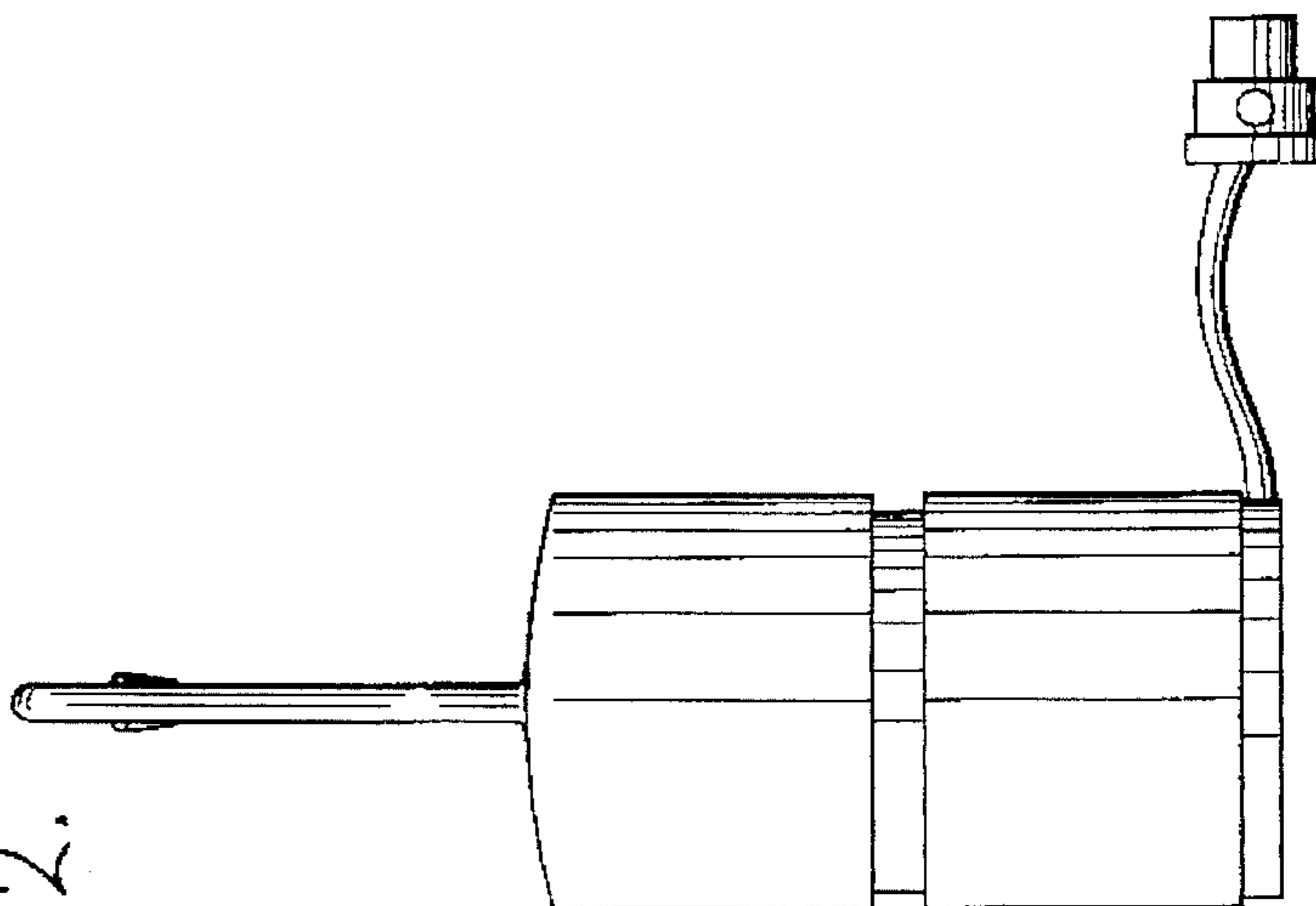

FIG. 5.

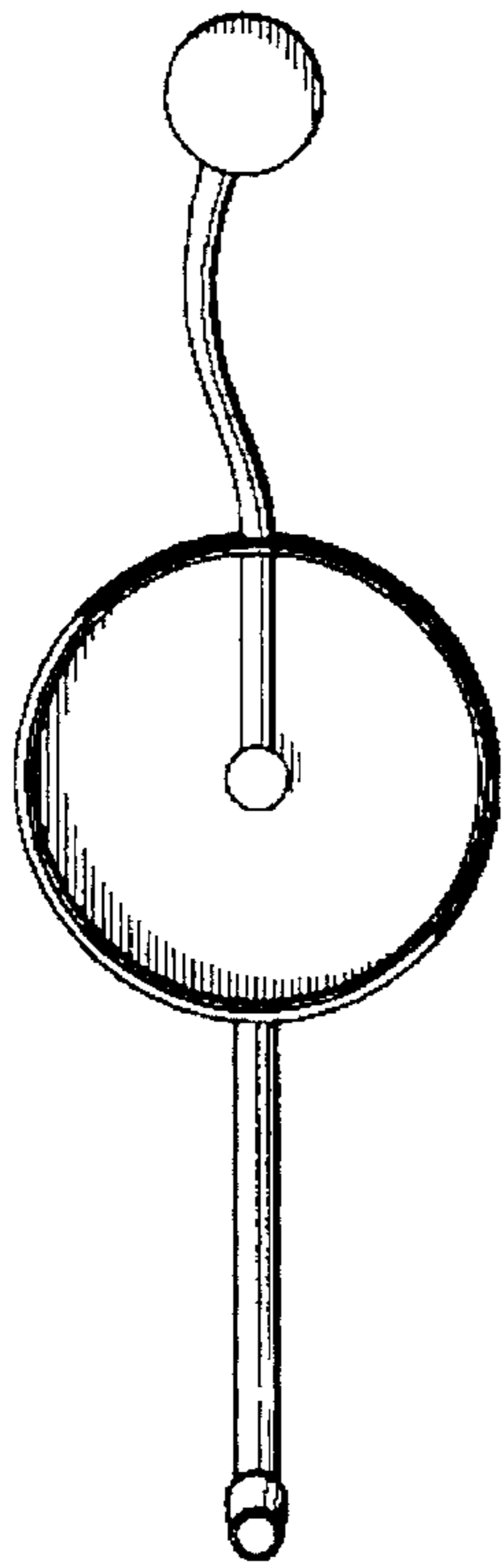

FIG. 6.

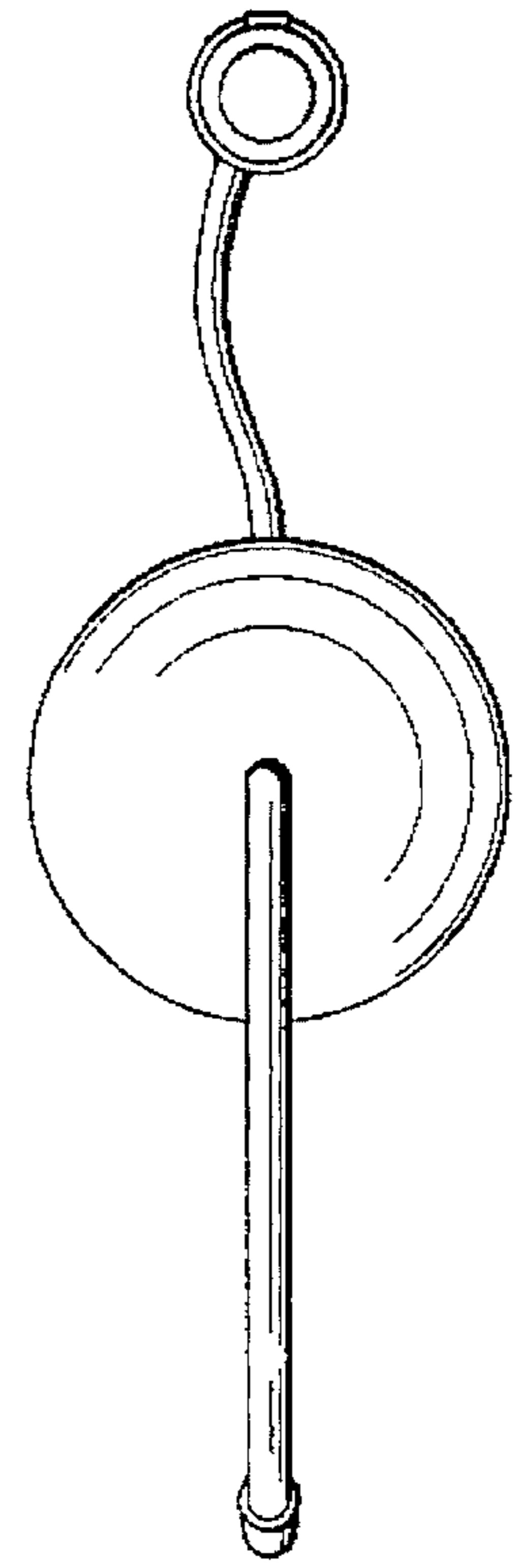

FIG. 4.

