



US00D372498S

# United States Patent [19]

[11] Patent Number: **Des. 372,498**

**Sato**

[45] Date of Patent: **\*\*Aug. 6, 1996**

[54] **PAPER CLIP**

*Primary Examiner*—Martie Thompson  
*Attorney, Agent, or Firm*—Kanesaka & Tekeuchi

[76] Inventor: **Hisao Sato**, Fujimidai Mansion 2002,  
29-10, Nukui 1-Chome, Nerima-Ku,  
Tokyo, Japan

[57] **CLAIM**

[\*\*] Term: **14 Years**

The ornamental design for a paper clip, as shown and described.

[21] Appl. No.: **40,211**

**DESCRIPTION**

[22] Filed: **Jun. 13, 1995**

[52] U.S. Cl. .... **D19/65**; D8/395; D19/86

FIG. 1 is a perspective view of a paper clip showing my new design, the view showing a state with a pair of pinches thereof up;

[58] Field of Search ..... D8/382, 395; D19/35,  
D19/65, 86, 88, 90; 24/67 r, 67.1-67.11,  
499, 500-506, 180, 186, 545, 546, 558

FIG. 2 is a perspective view of the paper clip, the view showing a state with a pair of pinches thereof down;

[56] **References Cited**

FIG. 3 is a front view of the paper clip as shown in FIG. 1;

**U.S. PATENT DOCUMENTS**

FIG. 4 is a left side view of the paper clip as shown in FIG. 1, the right view being identical;

D. 302,242	7/1989	Belash .....	D8/395
D. 321,209	10/1991	Hikomori .....	D19/65
D. 321,210	10/1991	Hikomori .....	D19/65
1,435,917	11/1922	Ensign .....	24/558
1,965,554	7/1934	Mainwaring .....	24/558
4,532,680	8/1985	Hashimoto .....	24/67 R
4,696,081	9/1987	Yeu .....	24/558
4,761,862	8/1988	Hikomori .....	24/67.9

FIG. 5 is a cross sectional view taken along a line 5—5 in FIG. 3;

**FOREIGN PATENT DOCUMENTS**

169310	9/1921	United Kingdom .....	24/588
--------	--------	----------------------	--------

FIG. 6 is a top plan view of the paper clip as shown in FIG. 1; and,

FIG. 7 is a bottom plan view of the paper clip as shown FIG. 1.

**1 Claim, 3 Drawing Sheets**

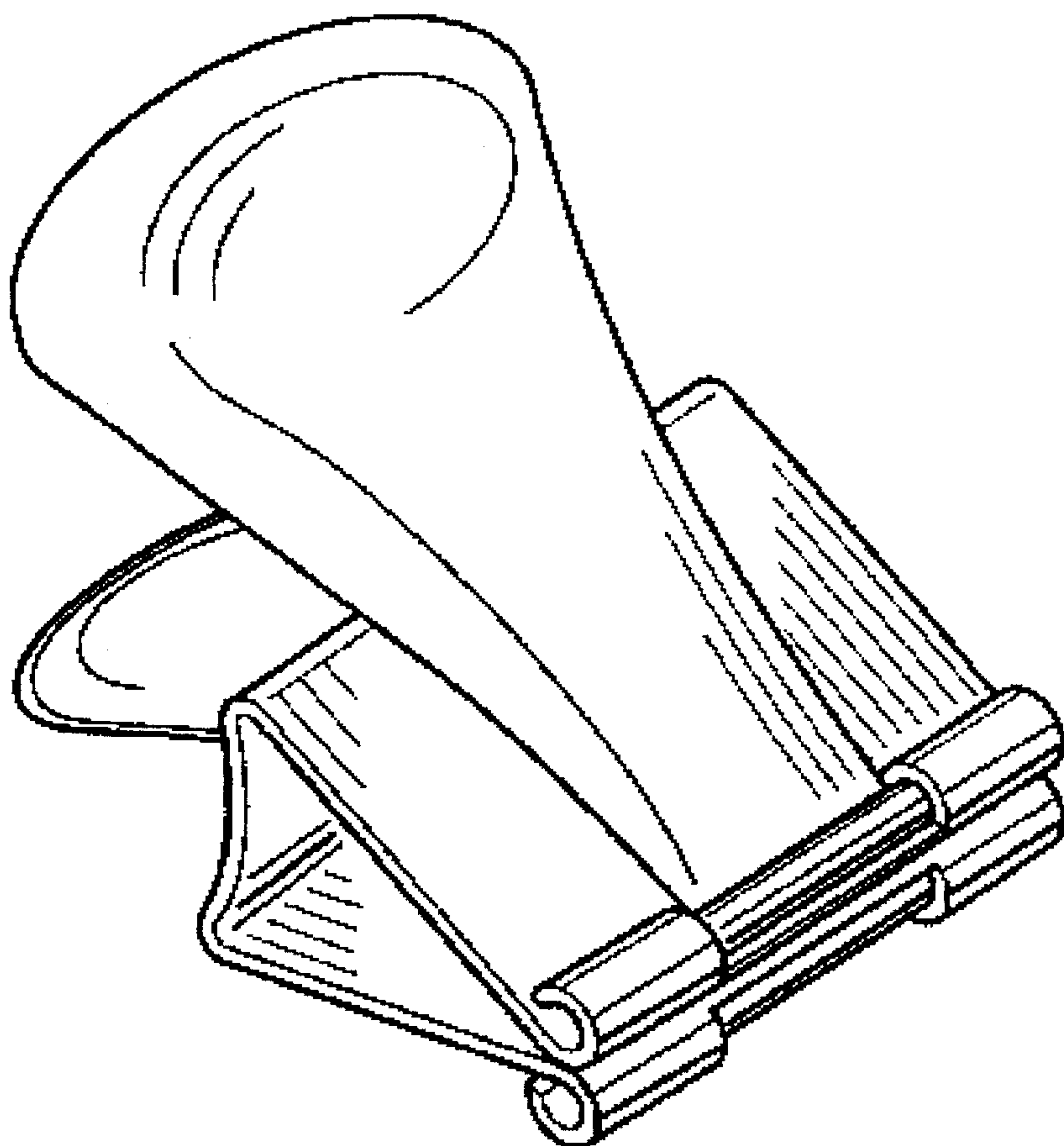

FIG. 1

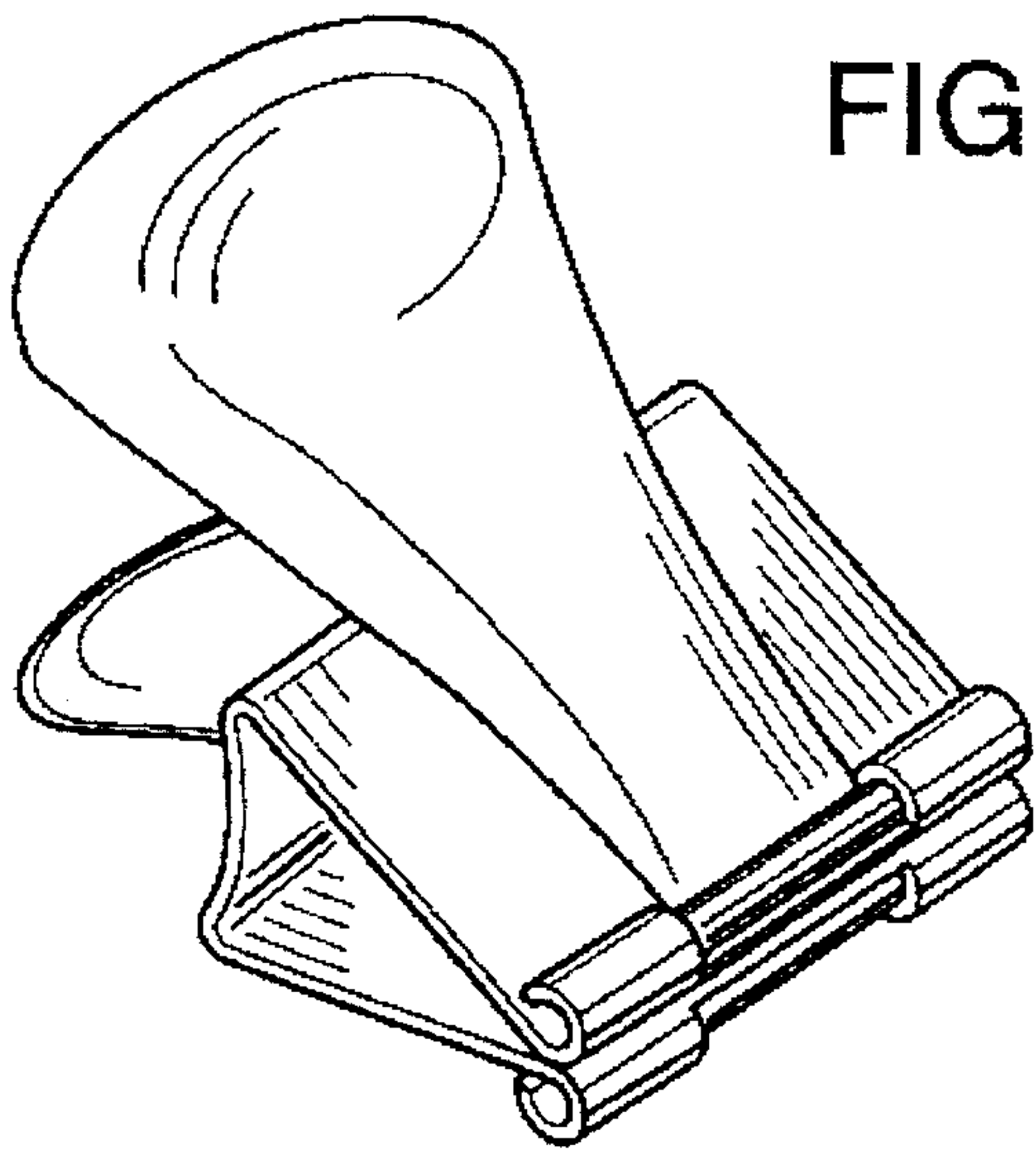

FIG. 2

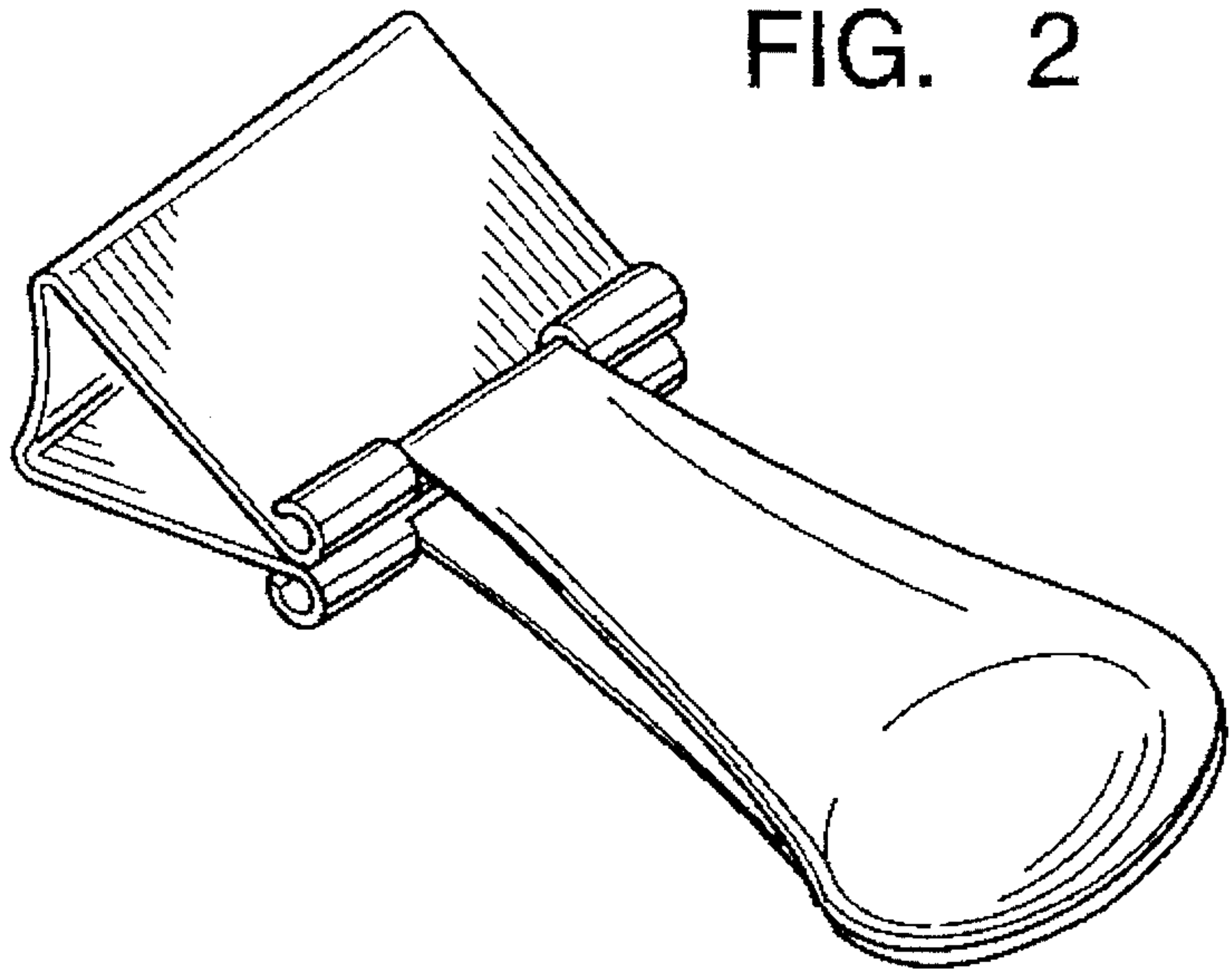
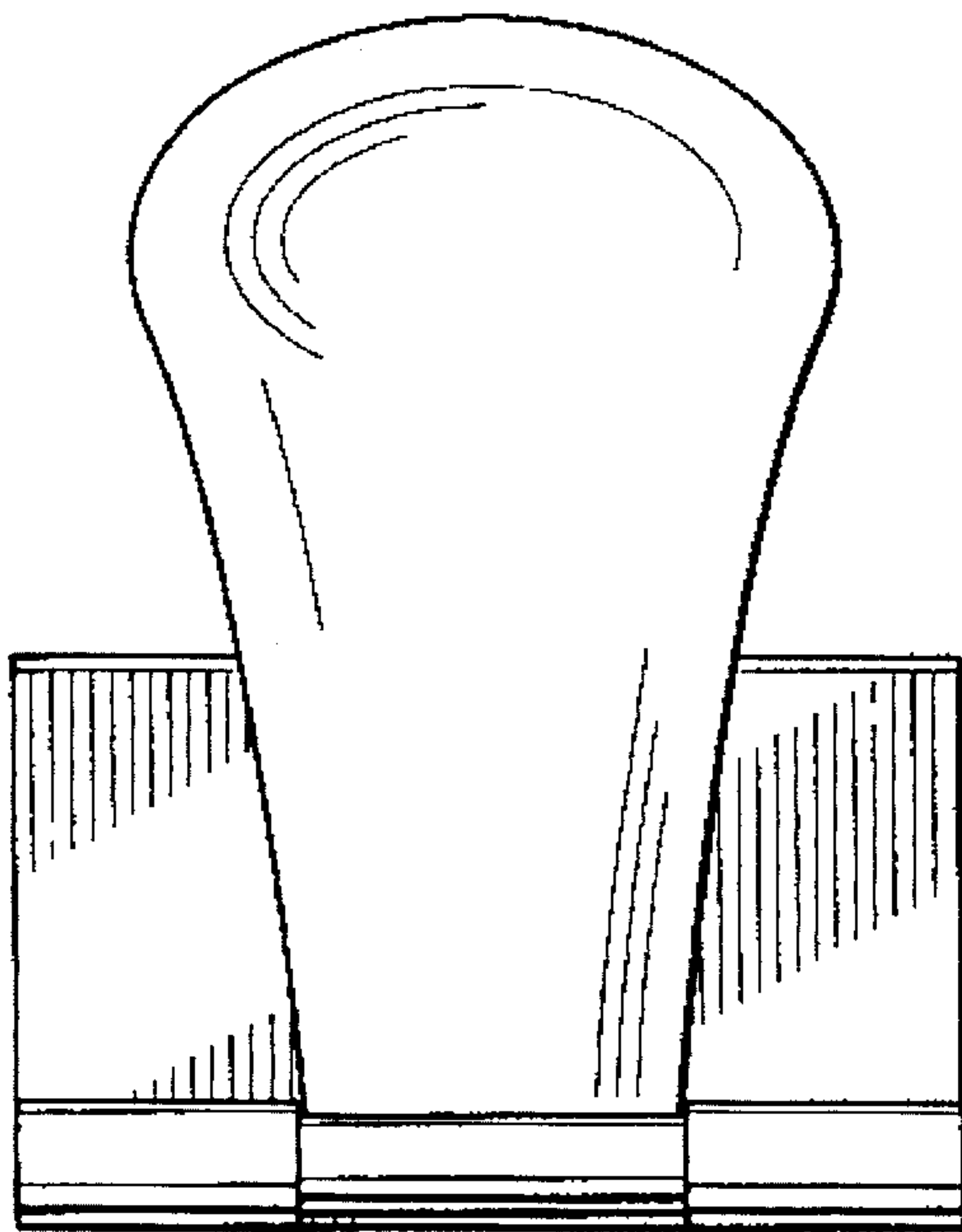

FIG. 3

5 ←



5 ←

FIG. 4

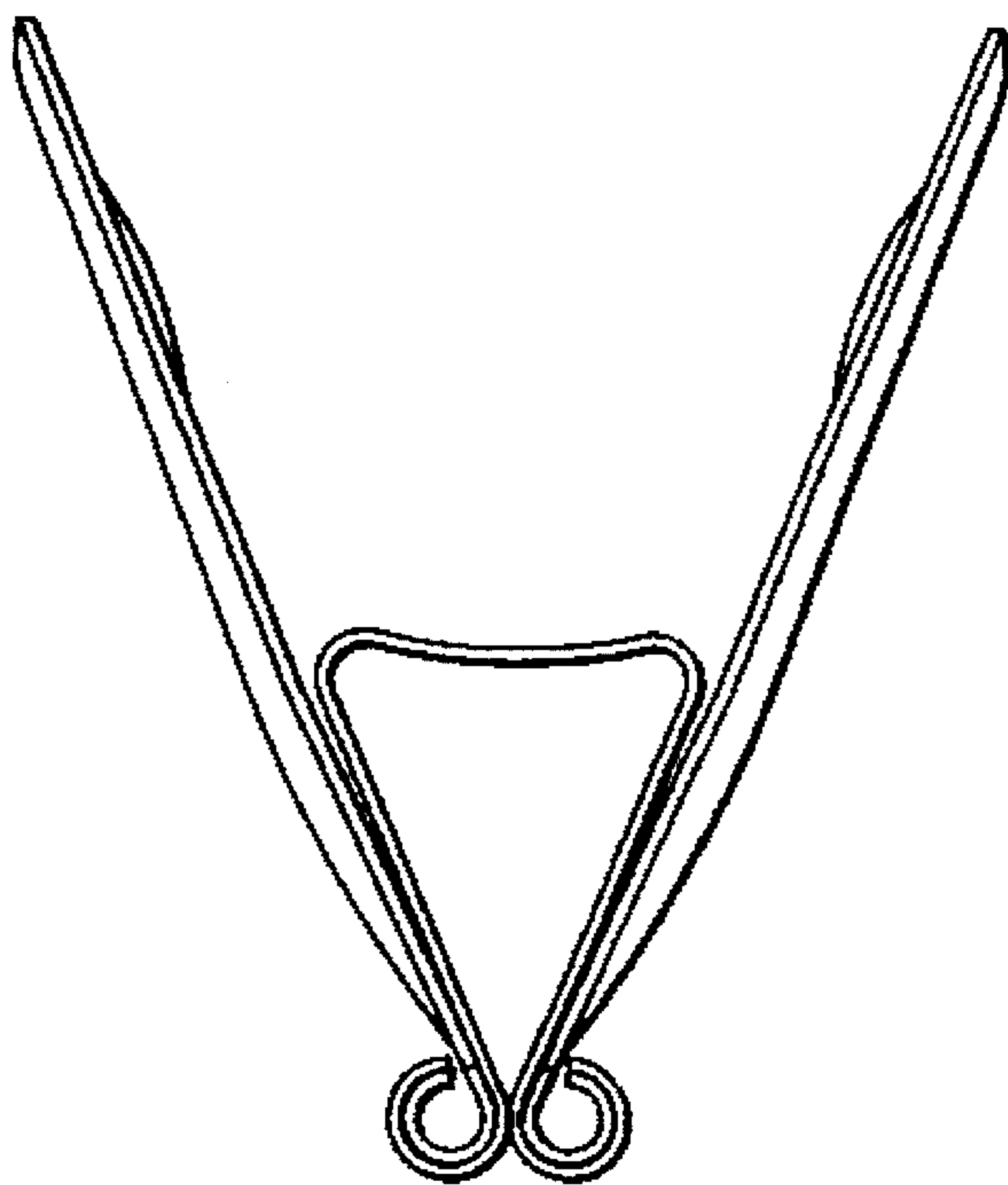

FIG. 5

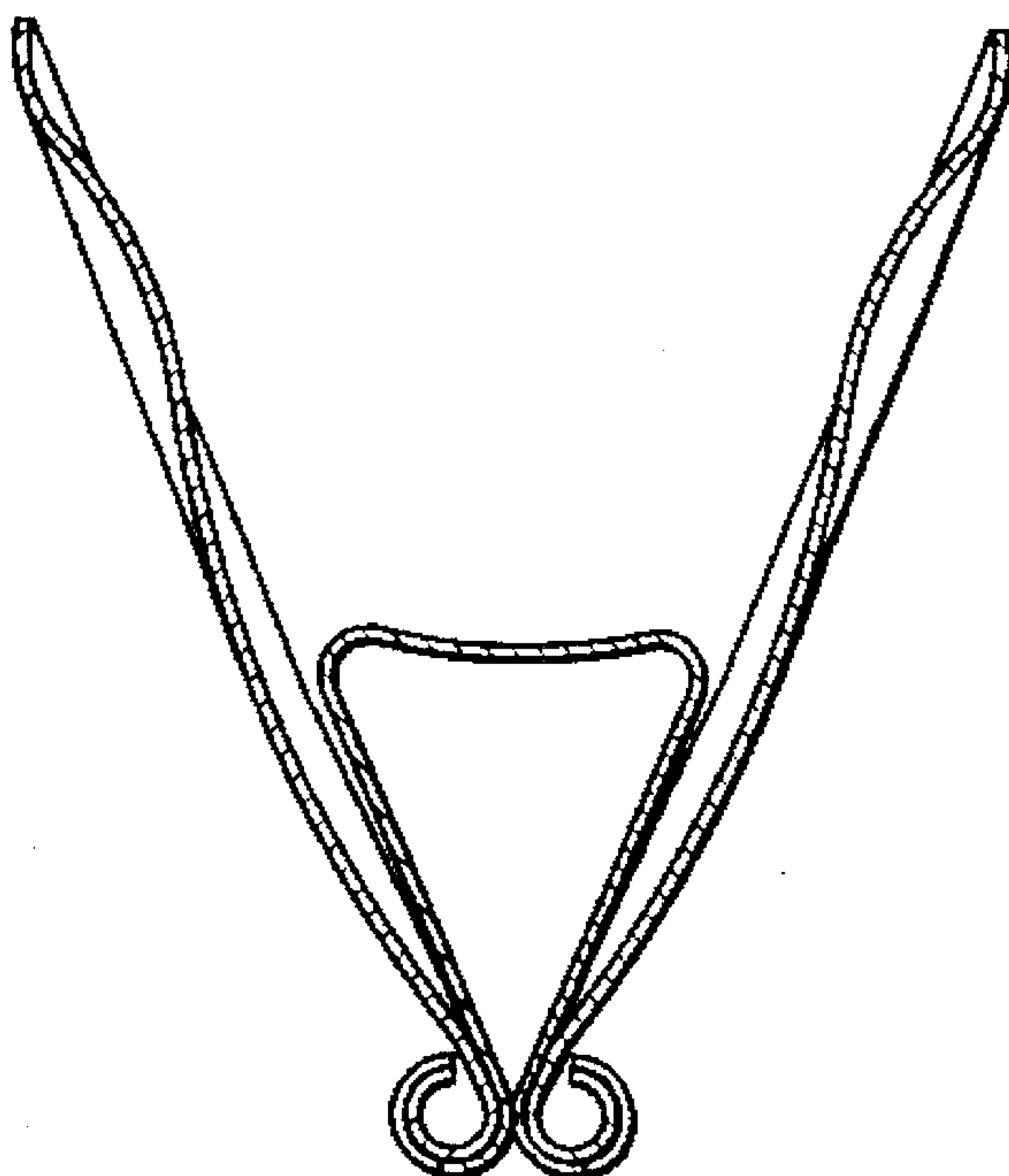

FIG. 6

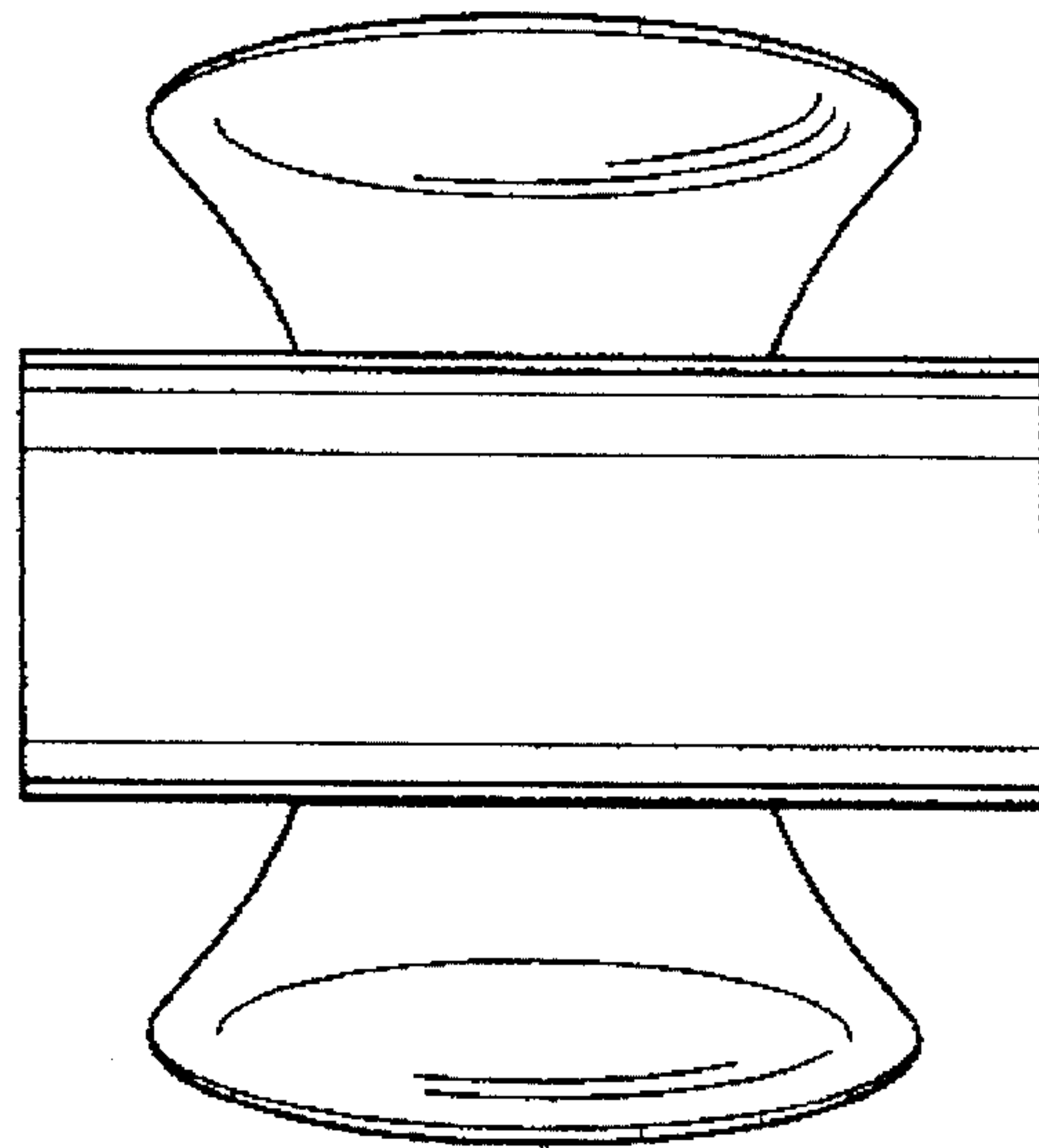

FIG. 7

