



US00D372441S

United States Patent [19]

Axe

[11] **Patent Number: Des. 372,441**

[45] **Date of Patent: **Aug. 6, 1996**

[54] MOTOR VEHICLE

[75] Inventor: **Royden Axe**, Warwick, England

[73] Assignee: **Rolls-Royce Motor Cars Limited**,
Crewe, England

[**] Term: **14 Years**

[21] Appl. No.: **29,270**

[22] Filed: **Sep. 1, 1994**

[30] Foreign Application Priority Data

Mar. 1, 1994 [GB] United Kingdom 2037417

[52] U.S. Cl. **D12/92**

[58] Field of Search D12/82, 86; 296/185

[56] References Cited

U.S. PATENT DOCUMENTS

D. 236,706 9/1975 Pininfarina D12/92

D. 327,238 6/1992 Honda et al. D12/92

D. 353,351 12/1994 Heffernan D12/92

OTHER PUBLICATIONS

Motor Trend (Jan. 1993) pp. 104-106, Bentley Continental.
Motor Trend (Sep. 1993) p. 88, Audi Cabriolet.

Primary Examiner—Brian N. Vinson
Attorney, Agent, or Firm—Cushman Darby & Cushman,
L.L.P.

[57] CLAIM

The ornamental design for a motor vehicle, as shown and described.

DESCRIPTION

FIG. 1 is a front elevational view of a motor vehicle showing my new design;

FIG. 2 is a rear elevational view thereof;

FIG. 3 is a right side elevational view thereof;

FIG. 4 is a left side elevational view thereof;

FIG. 5 is a top plan view thereof; and,

FIG. 6 is a bottom plan view thereof.

1 Claim, 5 Drawing Sheets

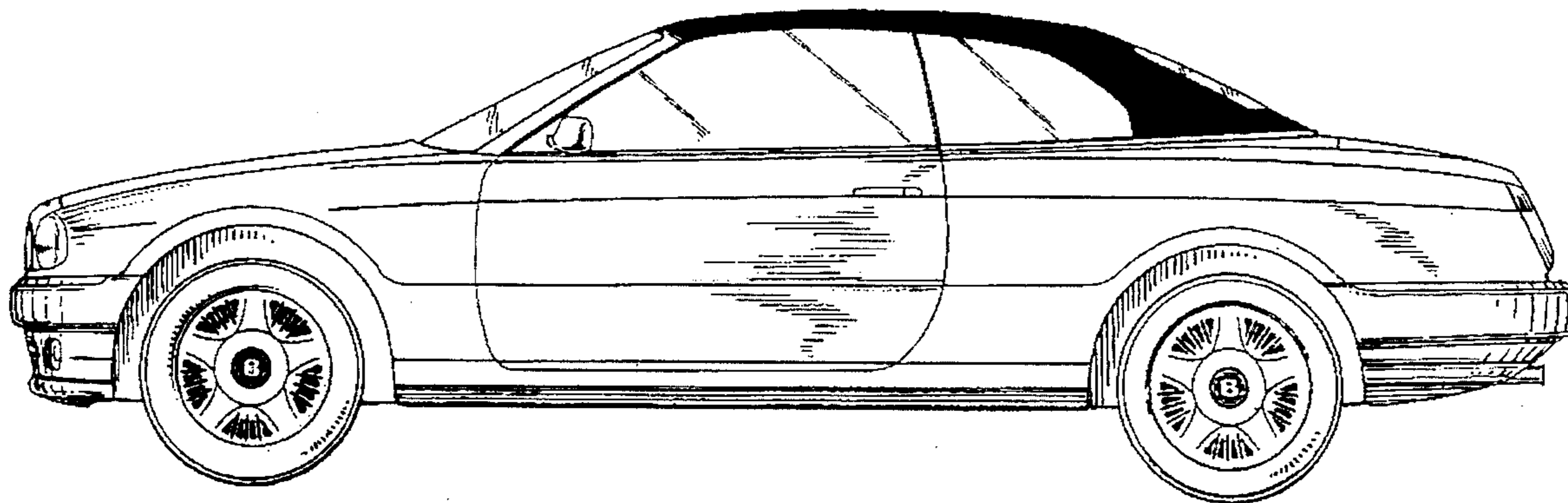
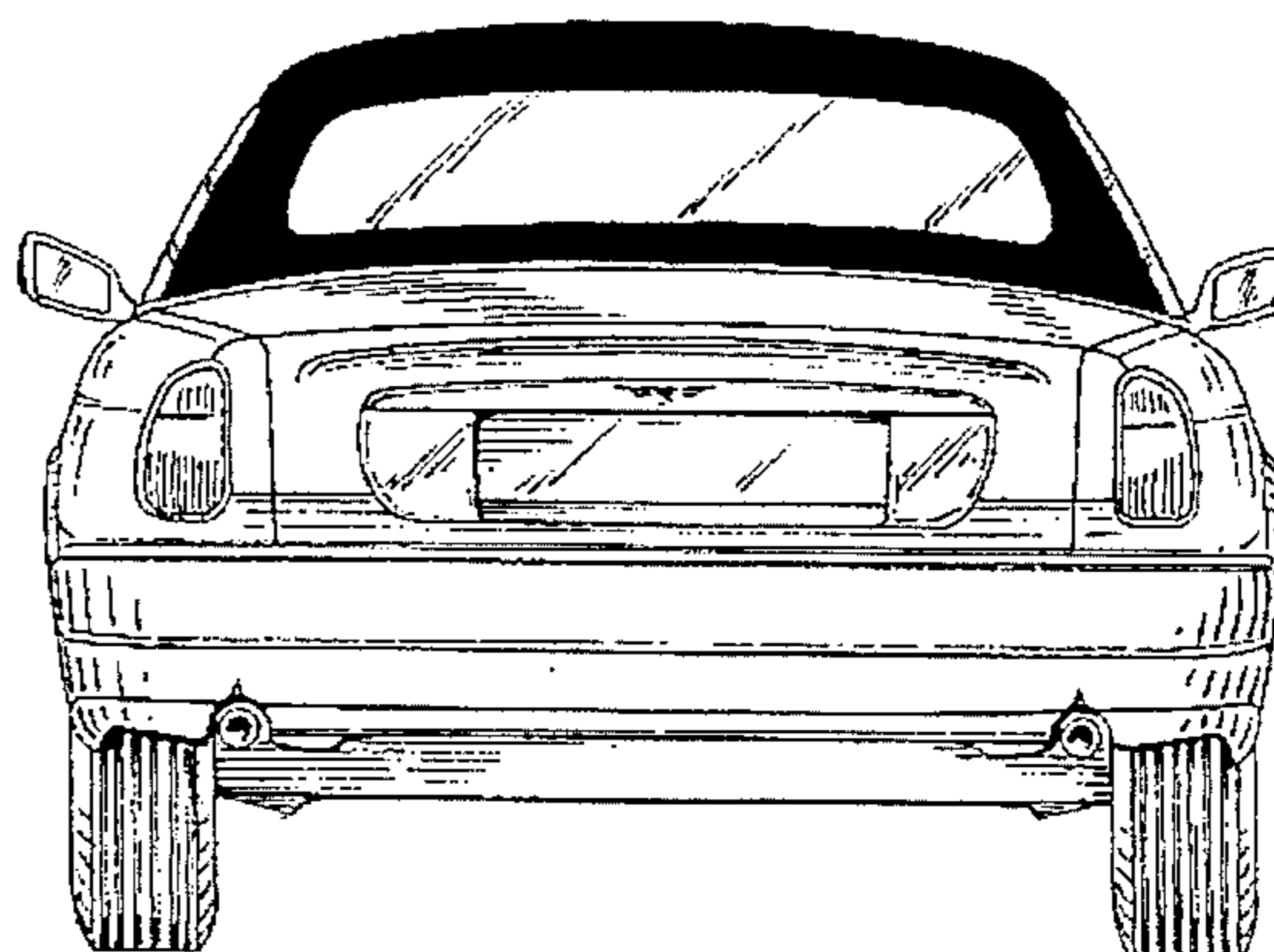
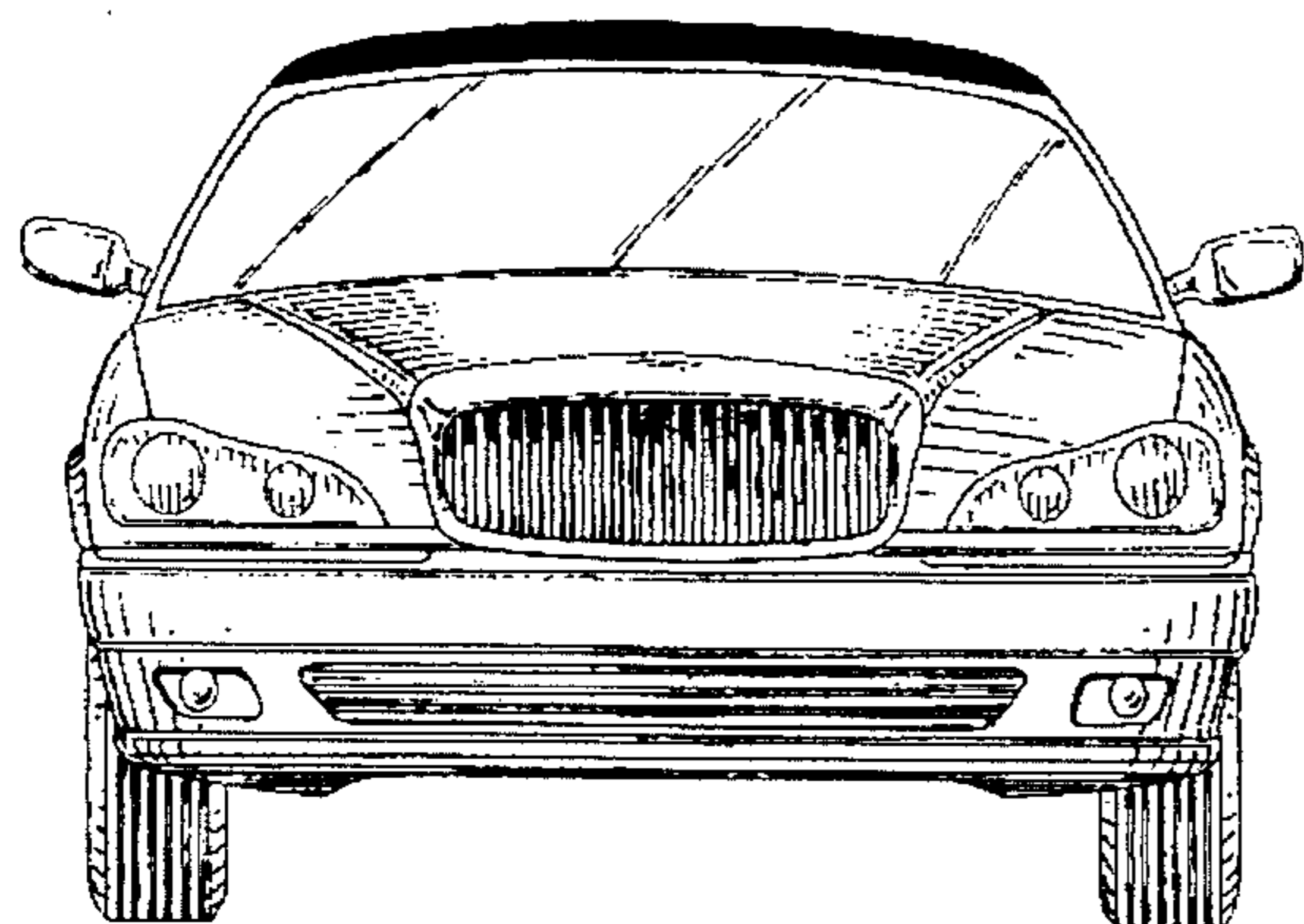

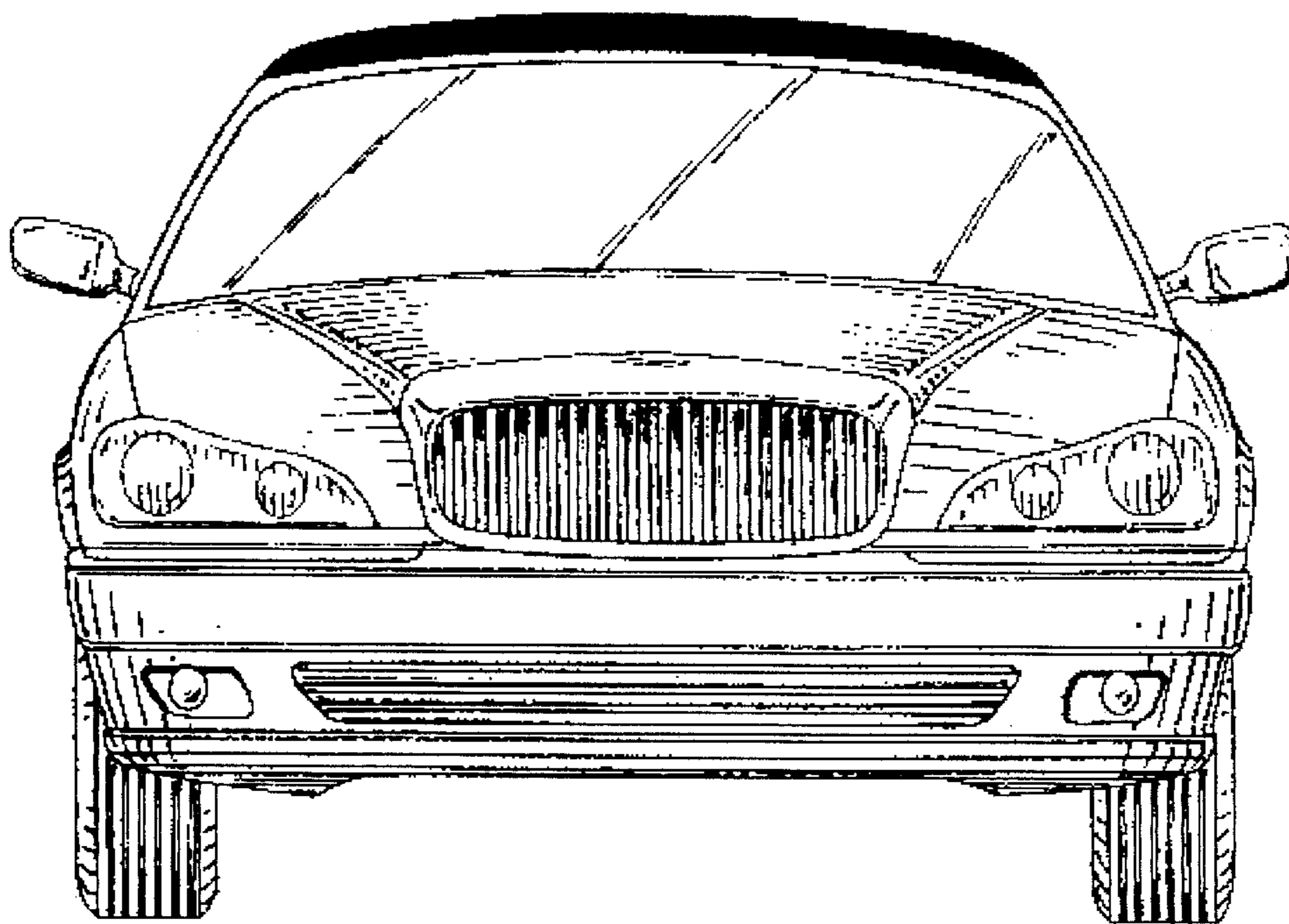

FIG. 1

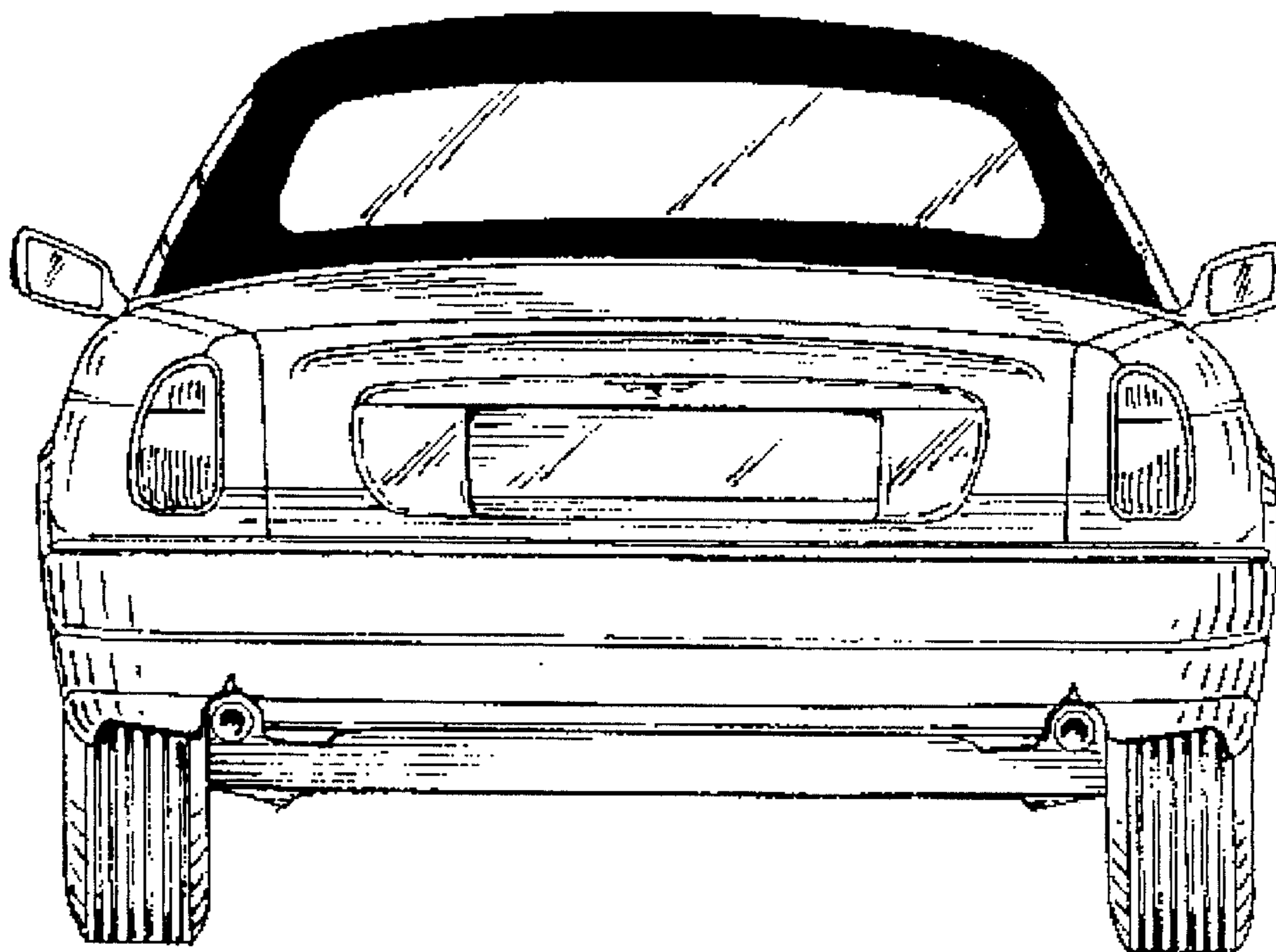
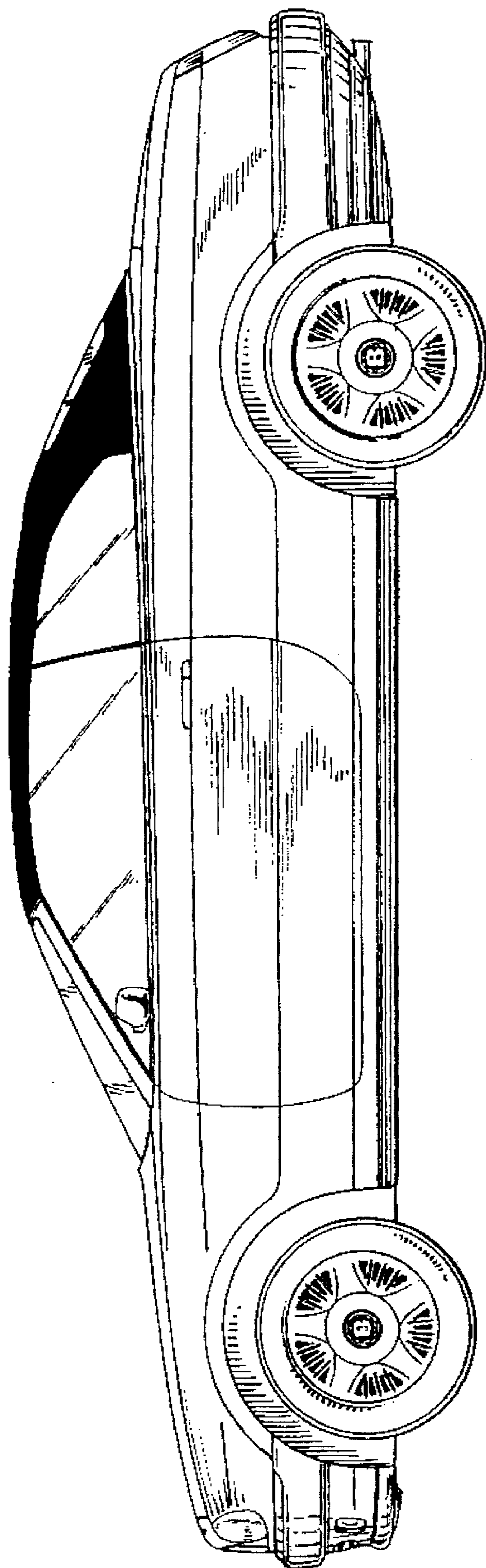

FIG. 2



FE3

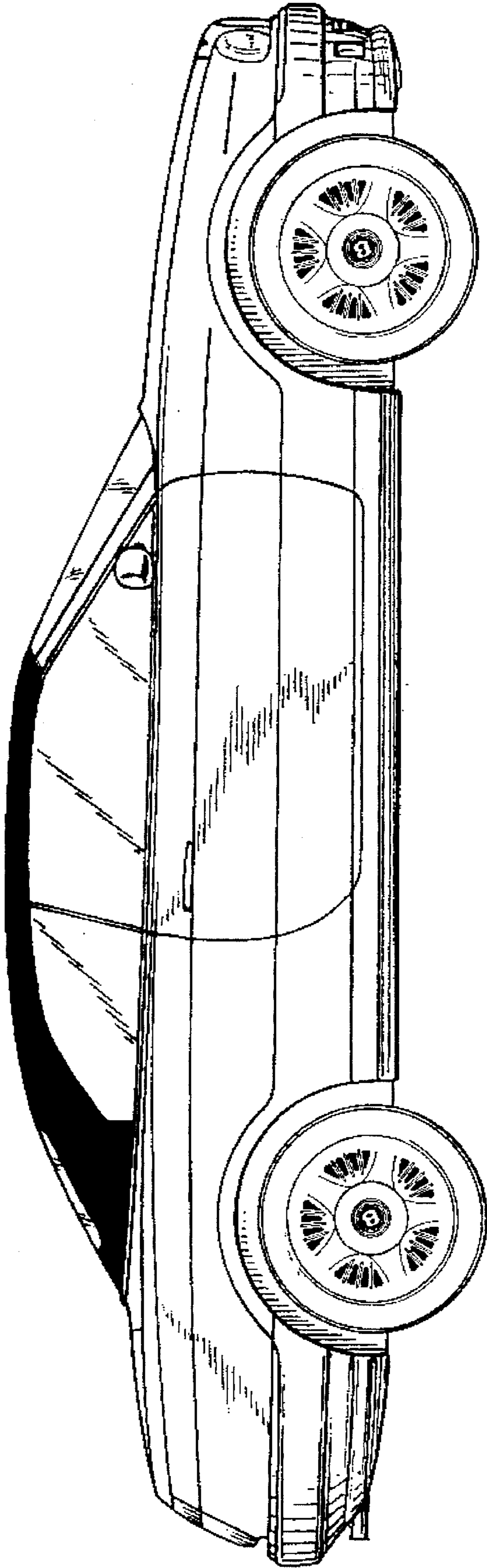

FIG. 4

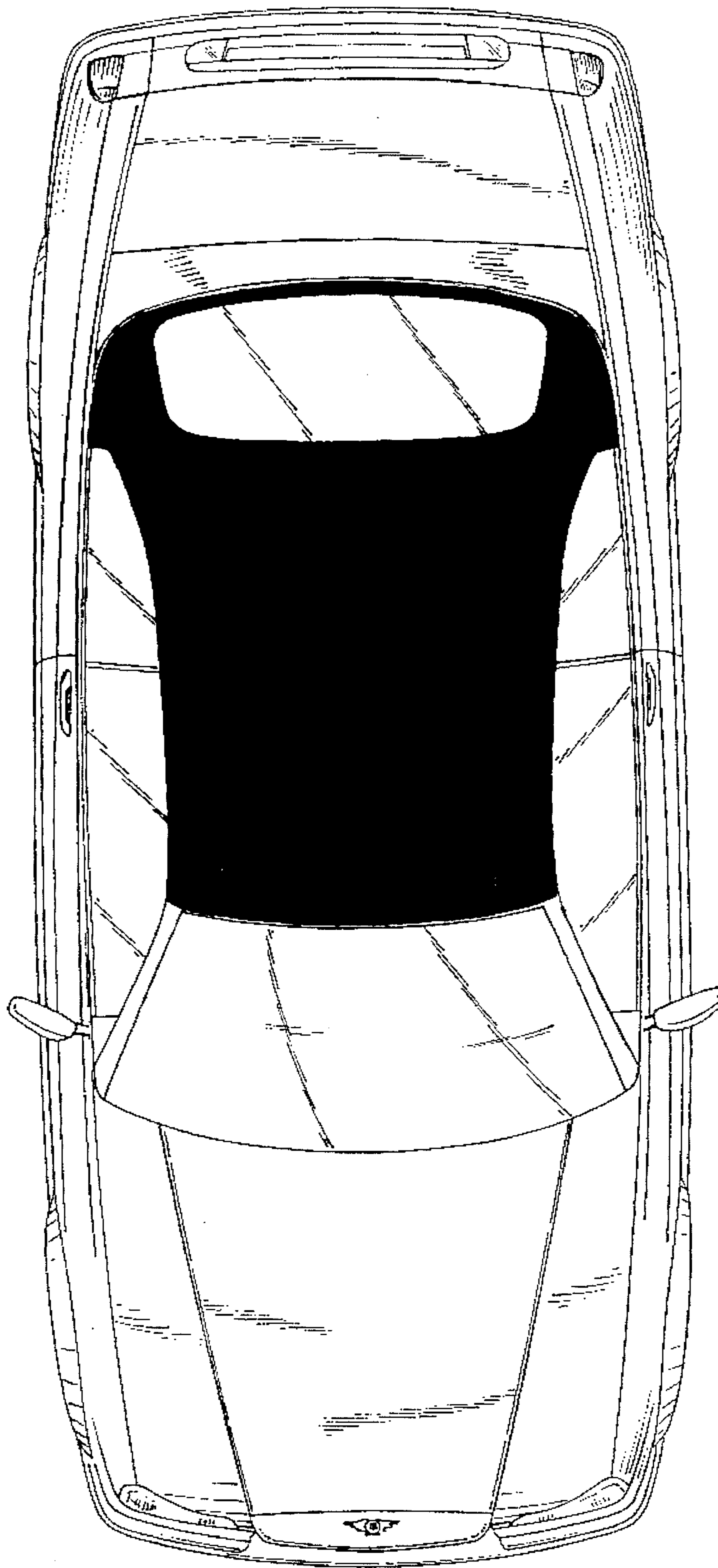

FIG. 5

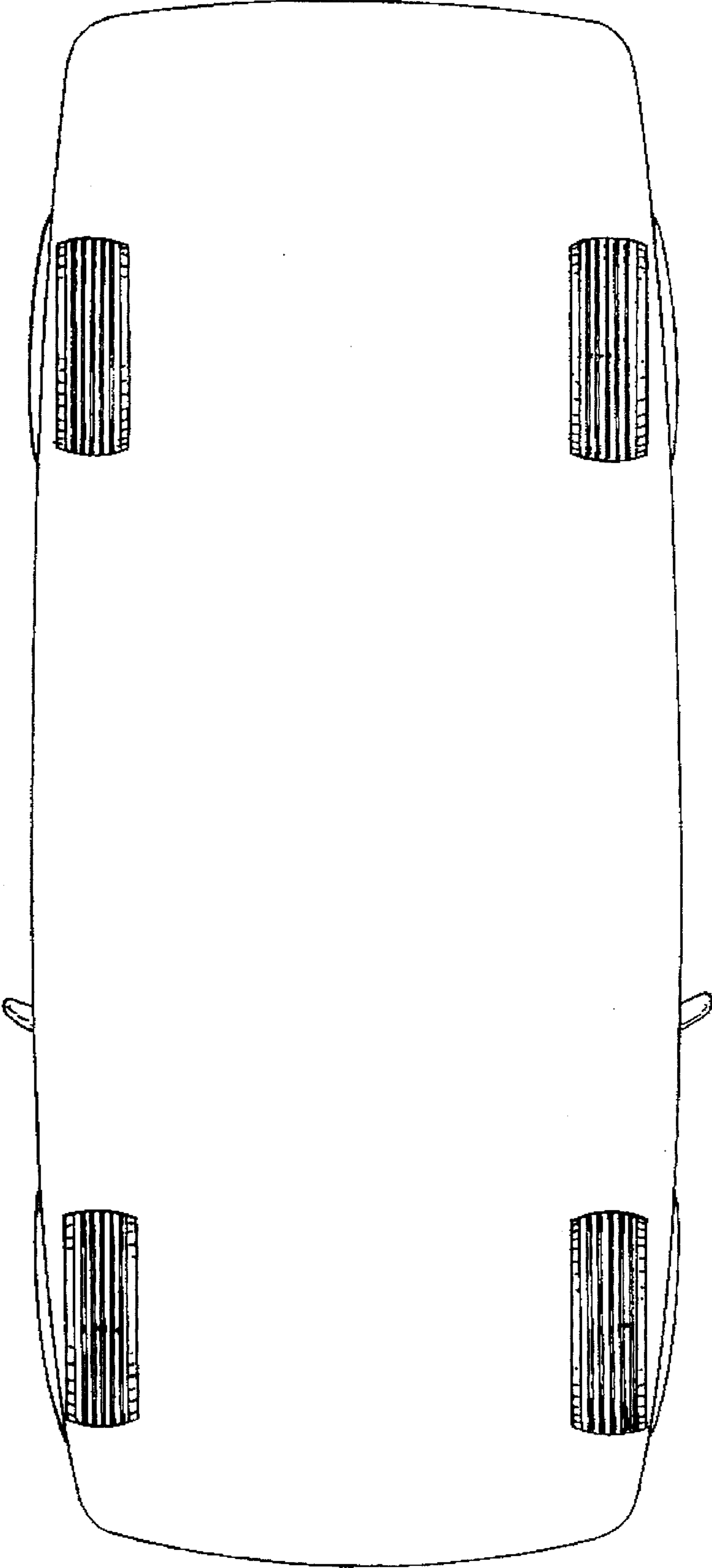

FIG. 6