



US00D372378S

United States Patent [19]
Kruger

[11] **Patent Number: Des. 372,378**

[45] **Date of Patent: **Aug. 6, 1996**

[54] **MODULAR STORAGE DRAWER**

[75] Inventor: **Cory J. Kruger**, Gardner, Mass.

[73] Assignee: **Sterilite Corporation**, Townsend, Mass.

[**] Term: **14 Years**

[21] Appl. No.: **20,292**

[22] Filed: **Mar. 23, 1994**

[52] U.S. Cl. **D6/448**

[58] **Field of Search** D6/432, 448, 509-511;
D9/418, 432, 424, 425; D3/305, 304-314;
D19/75, 99, 52; 206/425; 224/273, 42.11,
42.42

[56] **References Cited**

U.S. PATENT DOCUMENTS

D. 255,518	6/1980	Logsdon	D6/448
D. 279,952	8/1985	Daenen et al.	D9/425 X
D. 280,216	8/1985	Boklund	D19/52
D. 297,688	9/1988	Solomon et al.	D6/448
D. 302,774	8/1989	Murphy	D9/425 X
D. 313,817	1/1991	Thomas	D19/75
D. 319,977	9/1991	Curry	D9/425
D. 327,705	7/1992	Aaldenberg et al.	D19/75
D. 330,161	10/1992	Schuh	D9/425 X
D. 351,184	2/1993	Kruger	.	

OTHER PUBLICATIONS

Basic Line "Jaffa Block w. Drawer" (U.S. made); 2 pc. Molded Frame (open grid); 1 pc. Molded Drawer (opaque) Frame (inner) width forms drawer guides, No. stacking feature; drawer sidewalls without stiffening Rim. (disor-tions) poor fits. date prior to Mar. 23, 1993.

Jap. Stacking Draw. syst. 1986 Trade Show; 2pc Frame all enclosed, opaque; 1 pc Molded Drawer, all clear; Frame top attaches w/tabs on frame bottom; inner rib struct. for "rack-ing" re-enforcement; Integral handle in drawer front; lid distortion, does not impair function.

Korean Stacking Drawer (circa 1992); 3 pc. Molded Frame (front bezel) clear. 1 pc. Molded Drawer, clear. Stacking feature, deodorant feature, Good function, Stacking feature. Too many ribs & offsets, heavy walls. To much weight for size.

Berg (U.S. made) 1 pc. Molded frame (thick wall, styrene); 1 pc, Molded Drawer (thick wall, styrene). Poor sliding co-efficient, too heavy. Stacking feature. date prior to Mar. 23, 1993.

A. Bee-"Stax"; Single & Multiple drawer/frame system; 1 pc. Molded Frame-opaque; 2 pc. Molded Drawer (snap assy.)-clear.

Extremely distorted, bad function, flimsy. Stacking feature. date prior to Mar. 23, 1993.

Tenex Modular Storage (drawer) syst. (circa 1991)l 1 pc. Molded Frame (opaque); 2 pc. Molded Drawer (clear); Excessive clearance, distortion, Poor function (poor drawer guide motion) Poor stacking feature, or, rubber foot pads. date prior to Mar. 23, 1993.

Rubbermaid Stacking Drawers (1992); 2 pc. Molded Frame-(opaque); 1 pc. Molded Drawer (clear); Poor drawer to frame fit, Excessive drawer side motion; Insufficient drawer guide interface; Minimal stacking surf. interface; require additional tabs for stacking ability.

Sterilite Storage Drawer #3300 (1980); 1 pc. Molded Frame (opaque); 1 pc. Molded Drawer (clear); #6600 (1980) same construction as #3300. Drawer frames have stacking fea-tures.

Sterilite Drawer #150 (1983); 2 pc. Molded Frame (opaque); 1 pc Molded Drawer (opaque); Frames shaped so that indiv. drawers can be stacked as well as frames w/o top-lid (2nd part of frame) will snap atop each other for a flush. Perm. connected struct. of several drawer units.

Sterilite Storage Drawer #1632 (1988); 1 pc. Molded Frame (opaque); 1 pc. Molded Drawer (clear); Drawer frames have stacking feature.

Sterilite Storage Drawer #1634 (1992); 1 pc. Molded Frame (opaque); 1 pc. Molded Drawer (check) Drawer frames having stacking feature.

Primary Examiner—Carmen H. Vales-Lado

Attorney, Agent, or Firm—Donald Brown; Ernest V. Linek

[57] **CLAIM**

The ornamental design for a modular storage drawer, as shown and described.

DESCRIPTION

FIG. 1 is a perspective view of a modular storage drawer showing my new design;

FIG. 2 is a top plan view thereof;

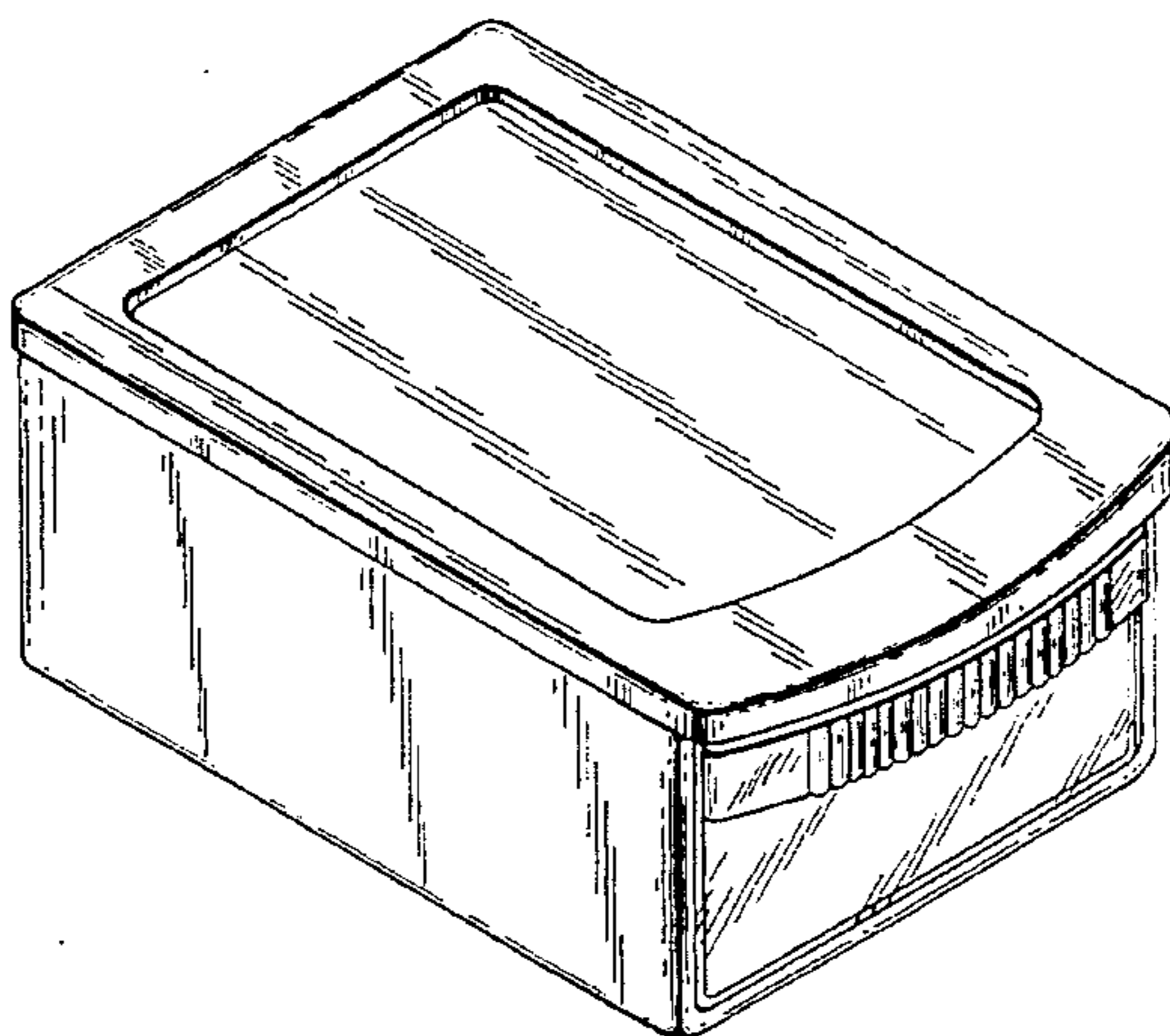

FIG. 3 is a side elevational view, the opposite side being a mirror image thereof;

FIG. 4 is a front elevational view thereof;

FIG. 5 is a rear elevational view thereof; and,

FIG. 6 is a bottom plan view thereof.

1 Claim, 3 Drawing Sheets

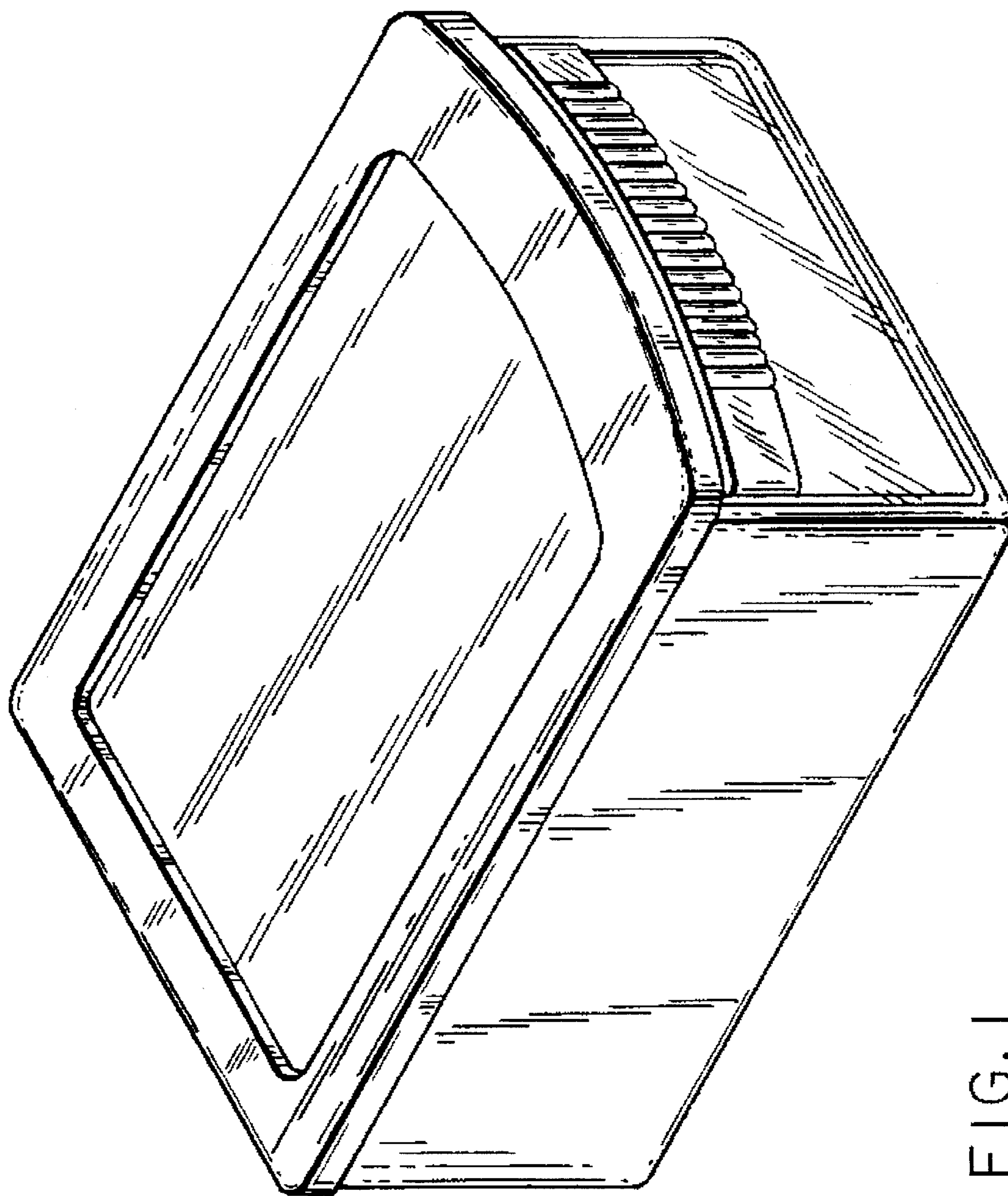

FIG. 1

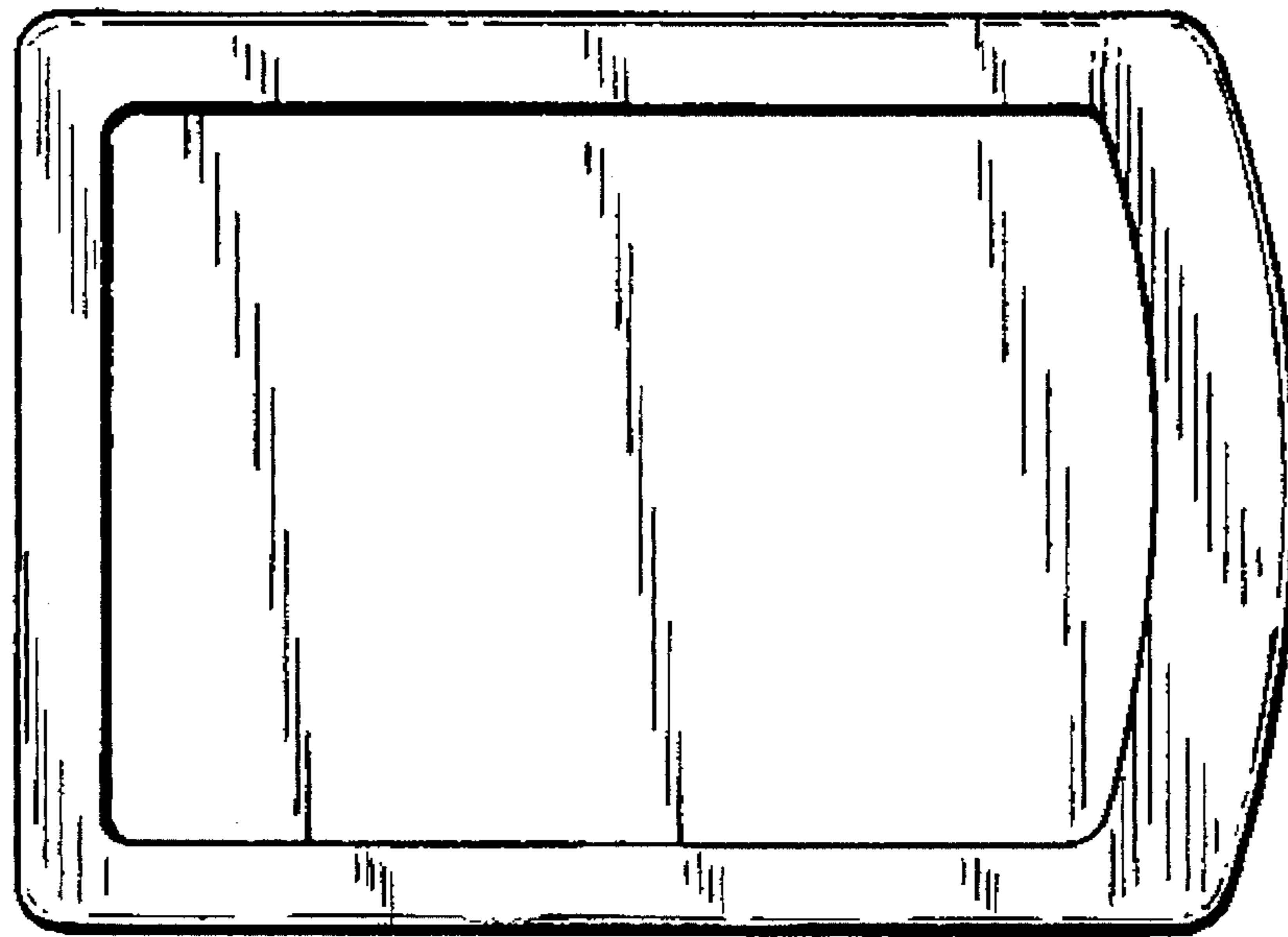

FIG. 2

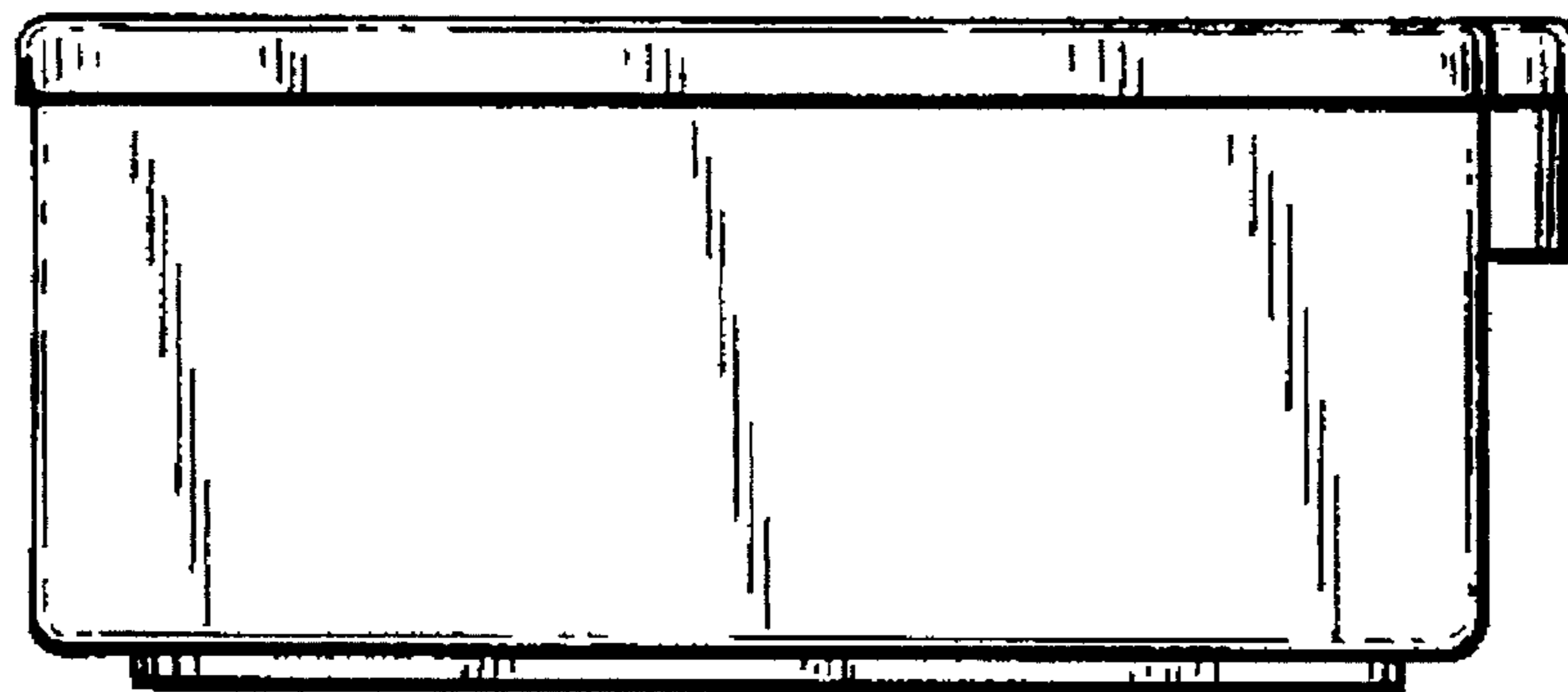

FIG. 3

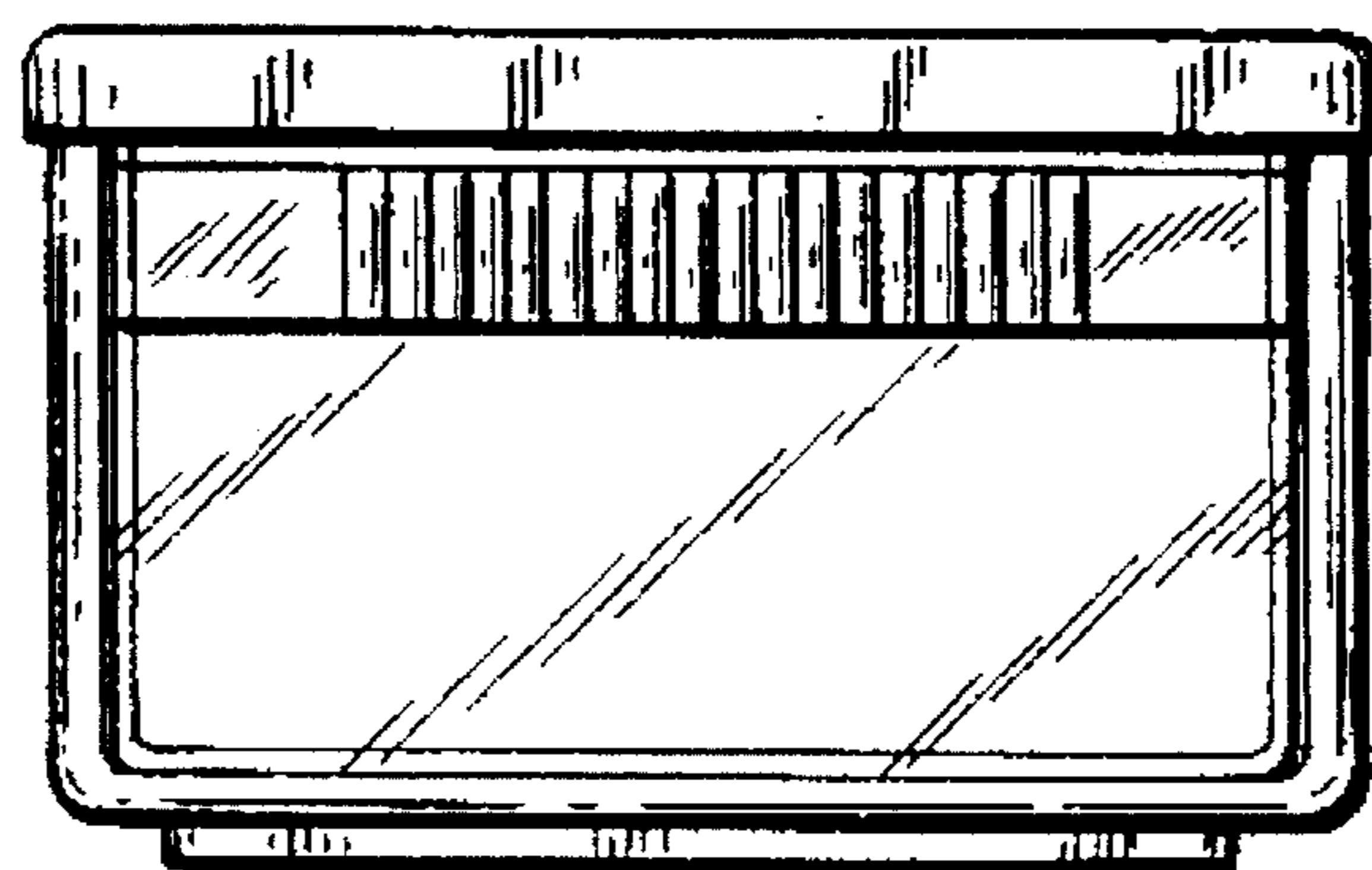

FIG. 4

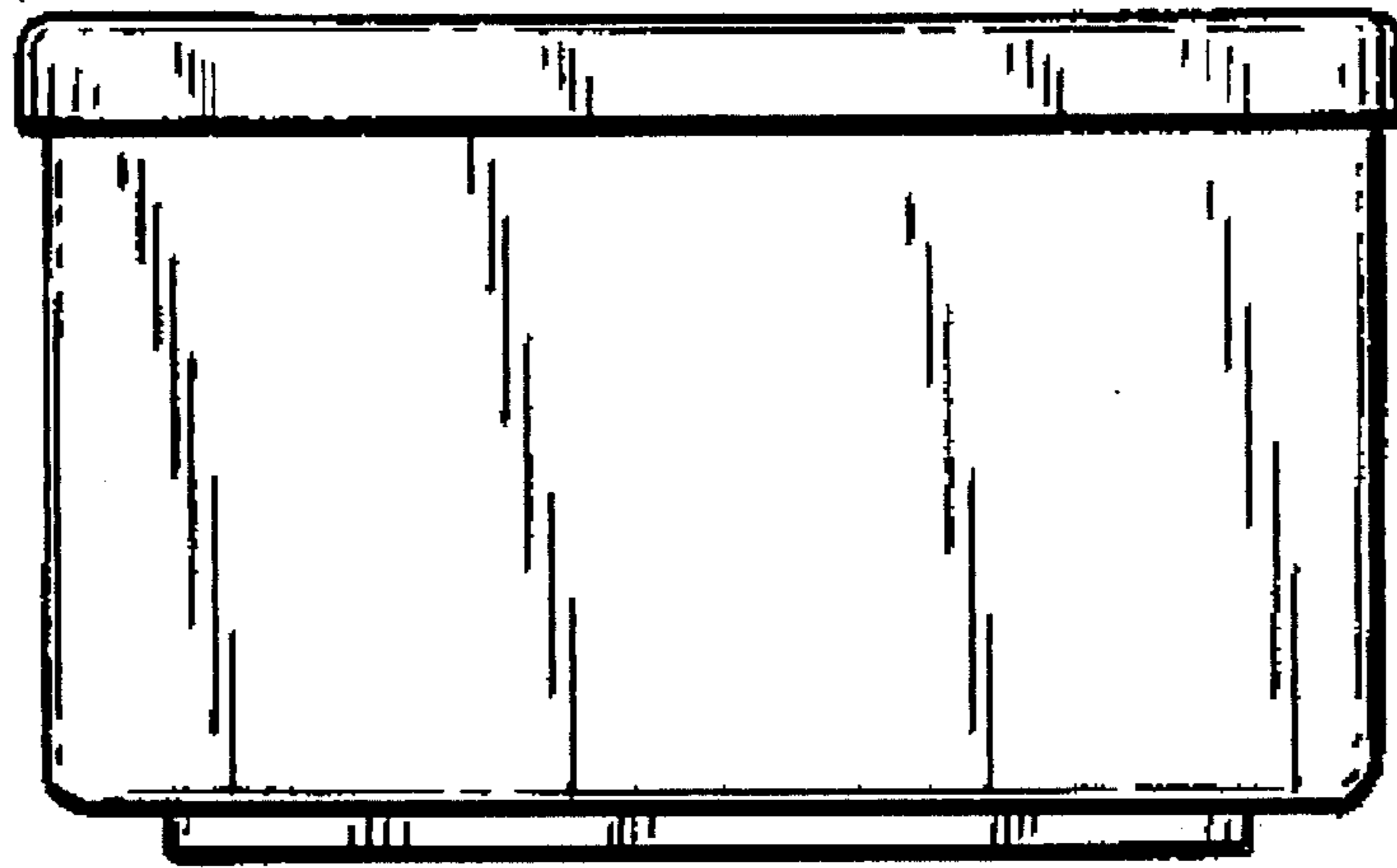

FIG. 5

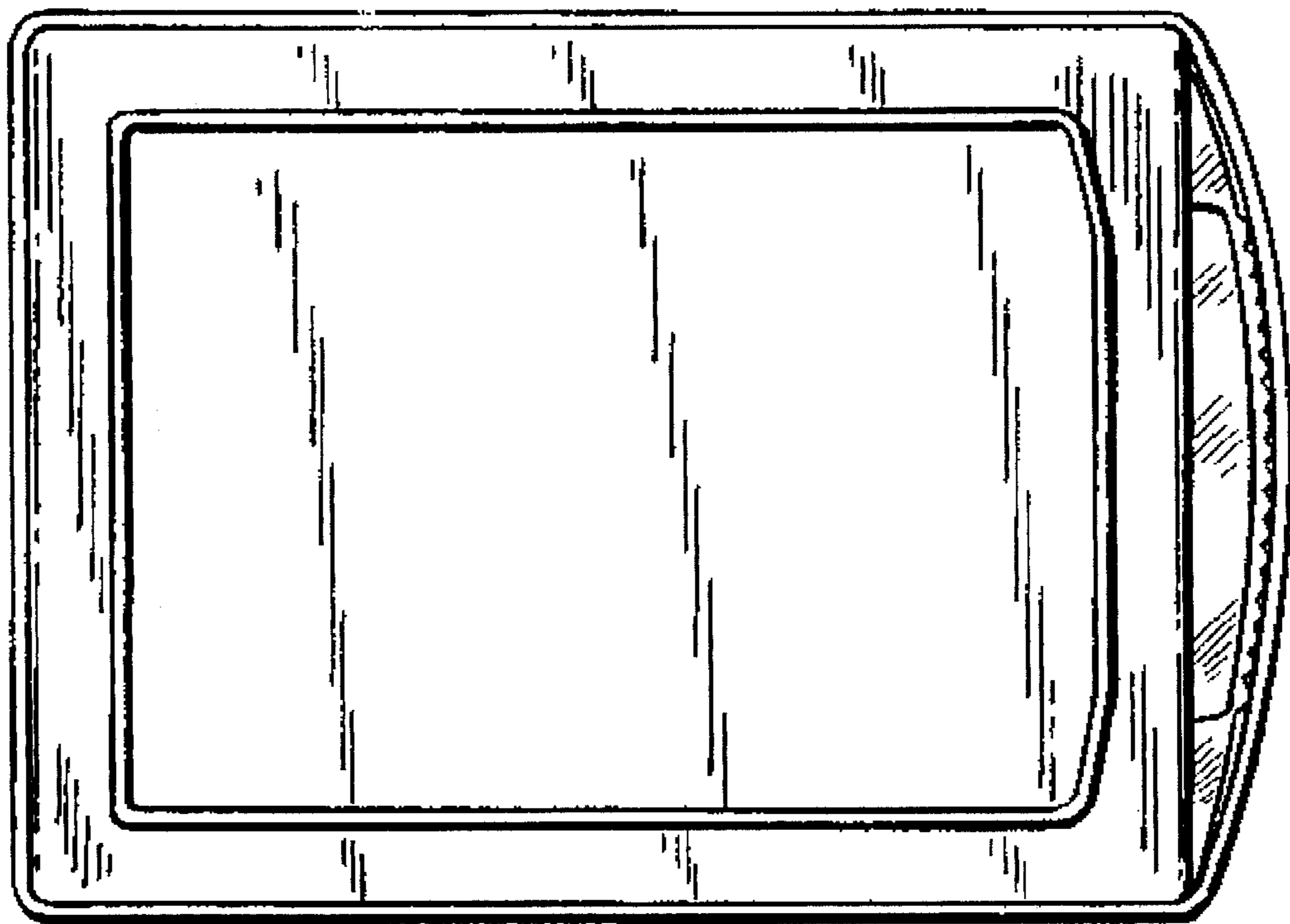

FIG. 6