



US00D372317S

**United States Patent** [19]  
**Kijima**

[11] **Patent Number: Des. 372,317**

[45] **Date of Patent: \*\*Jul. 30, 1996**

[54] **TAIL-LAMP FOR A VEHICLE**

*Primary Examiner*—Marcus A. Jackson

[76] **Inventor: Takayuki Kijima**, No. 57-7, 1-chome,  
Nishi-Nippori, Arakawa-ku, Tokyo 116,  
Japan

[57] **CLAIM**

The ornamental design for a tail-lamp for a vehicle, as shown and described.

[\*\*] **Term: 14 Years**

**DESCRIPTION**

[21] **Appl. No.: 19,047**

FIG. 1 is a front view of the tail-lamp for a vehicle having a semitransparent body cover;

[22] **Filed: Feb. 22, 1994**

FIG. 2 is a rear view of the tail-lamp for a vehicle;

[30] **Foreign Application Priority Data**

FIG. 3 is a right-side of the tail-lamp for a vehicle showing the semitransparent body cover wherein the right-side view being the same for the left-side view;

Oct. 27, 1993 [JP] Japan ..... 5-32656

[52] **U.S. Cl.** ..... **D26/28**

FIG. 4 is a plan view of the tail-lamp for a vehicle showing the semitransparent body cover;

[58] **Field of Search** ..... D26/28-35, 46,  
D26/37-50; 362/61, 72, 157, 158, 183-208

FIG. 5 is the bottom view of the tail-lamp for a vehicle showing the semitransparent body cover; and,

[56] **References Cited**

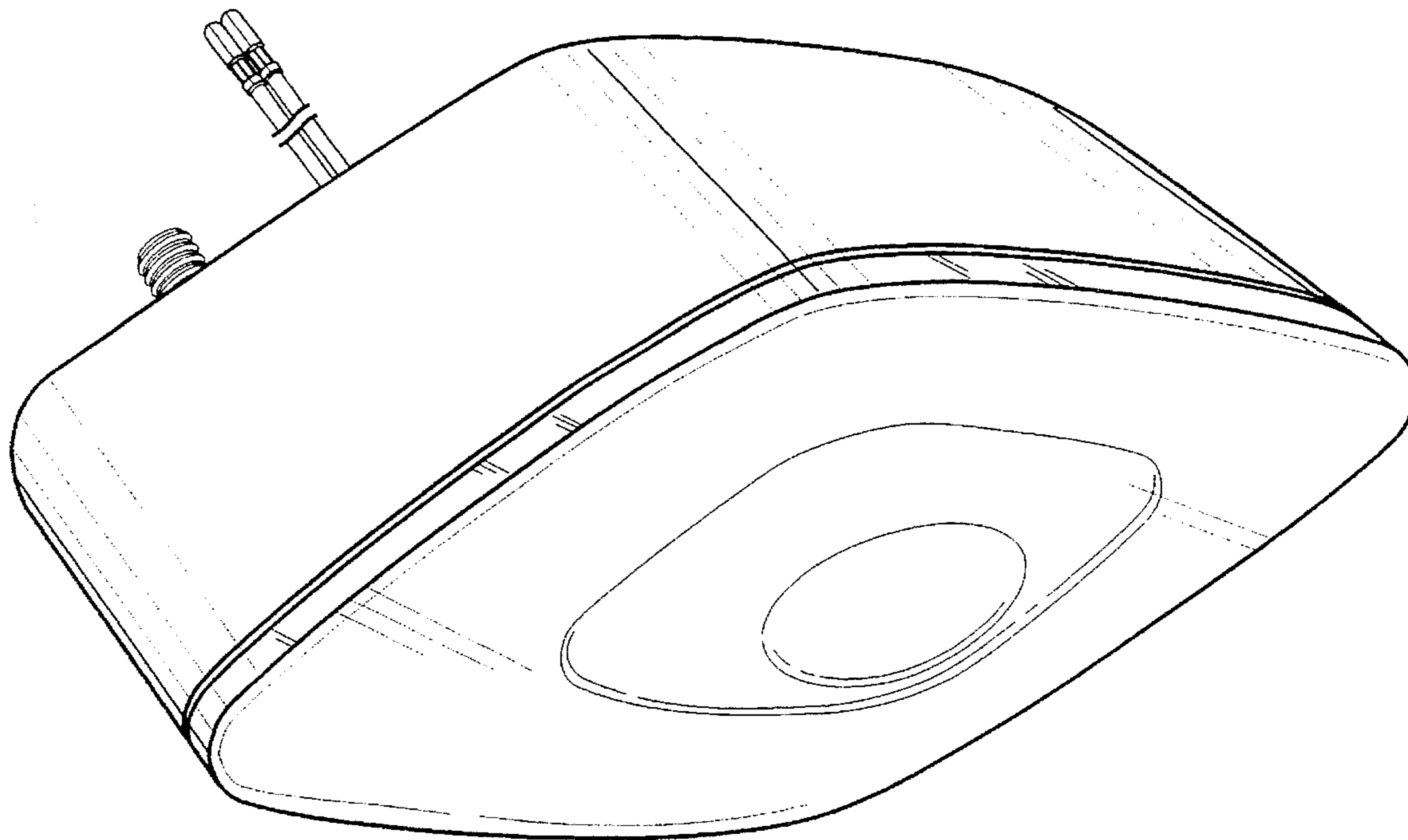
FIG. 6 is a perspective view of the tail-lamp from the front, top and left side.

**U.S. PATENT DOCUMENTS**

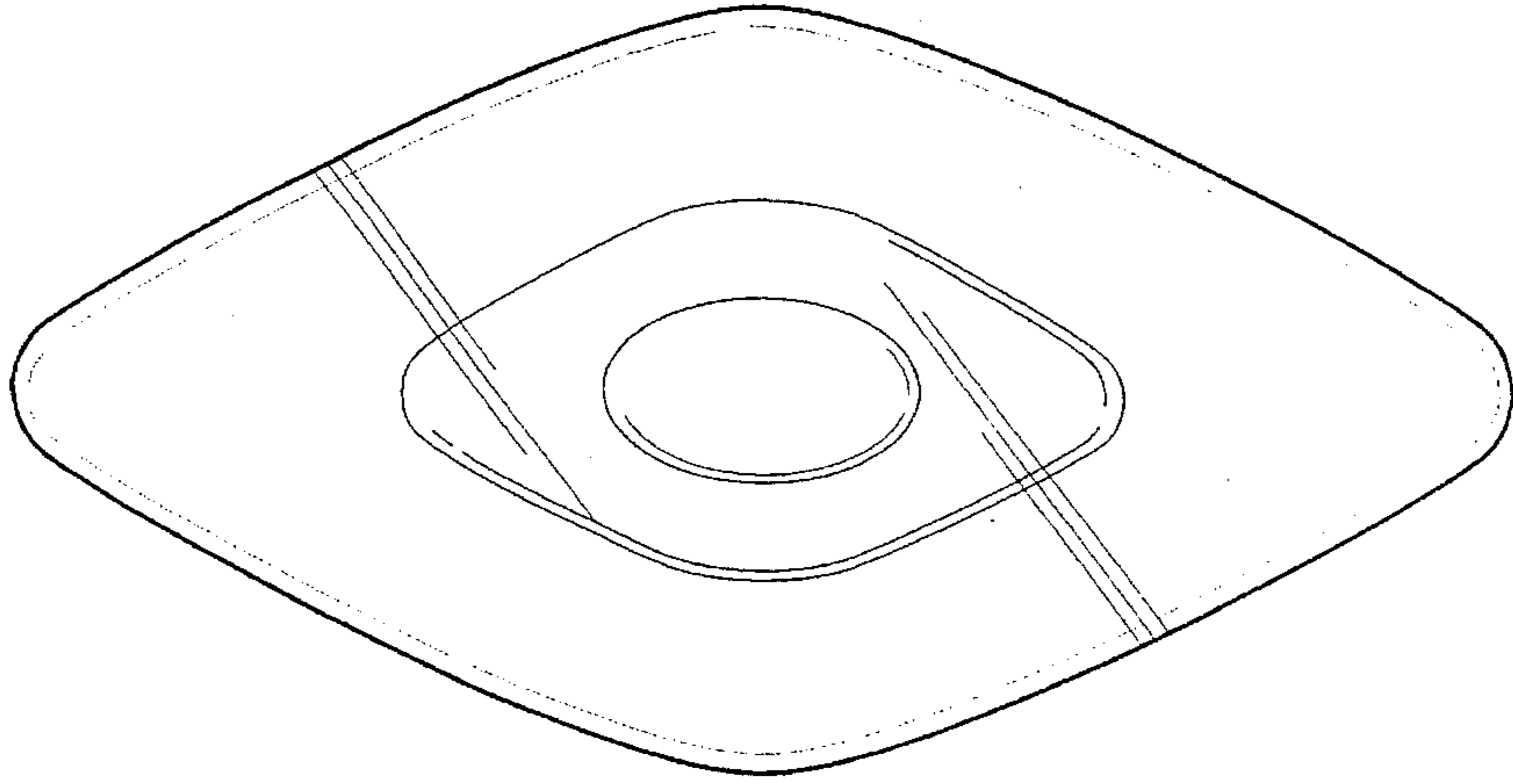
D. 324,577 3/1992 Tsuyama ..... D26/28

D. 346,231 4/1994 Zai ..... D26/28

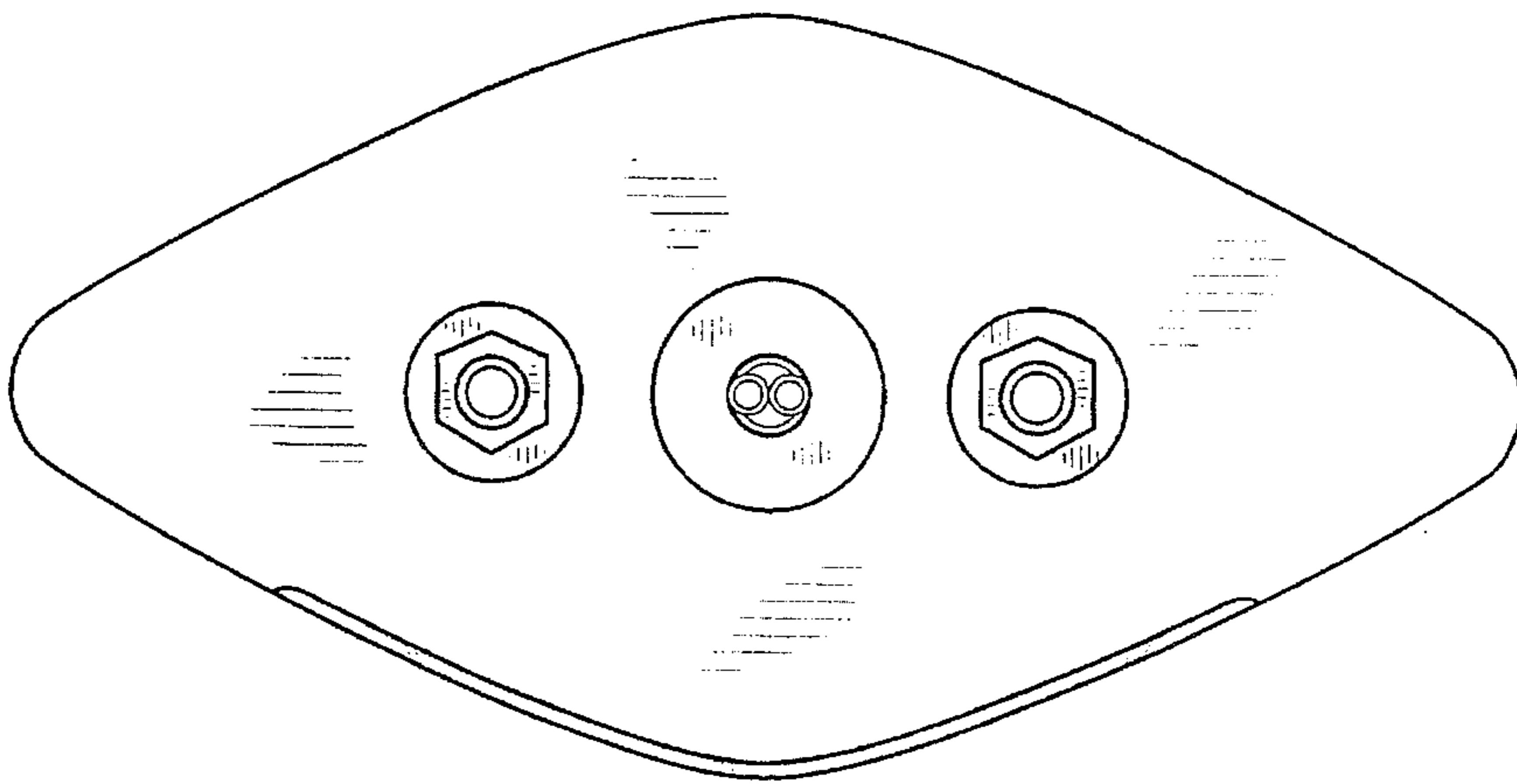
**1 Claim, 3 Drawing Sheets**



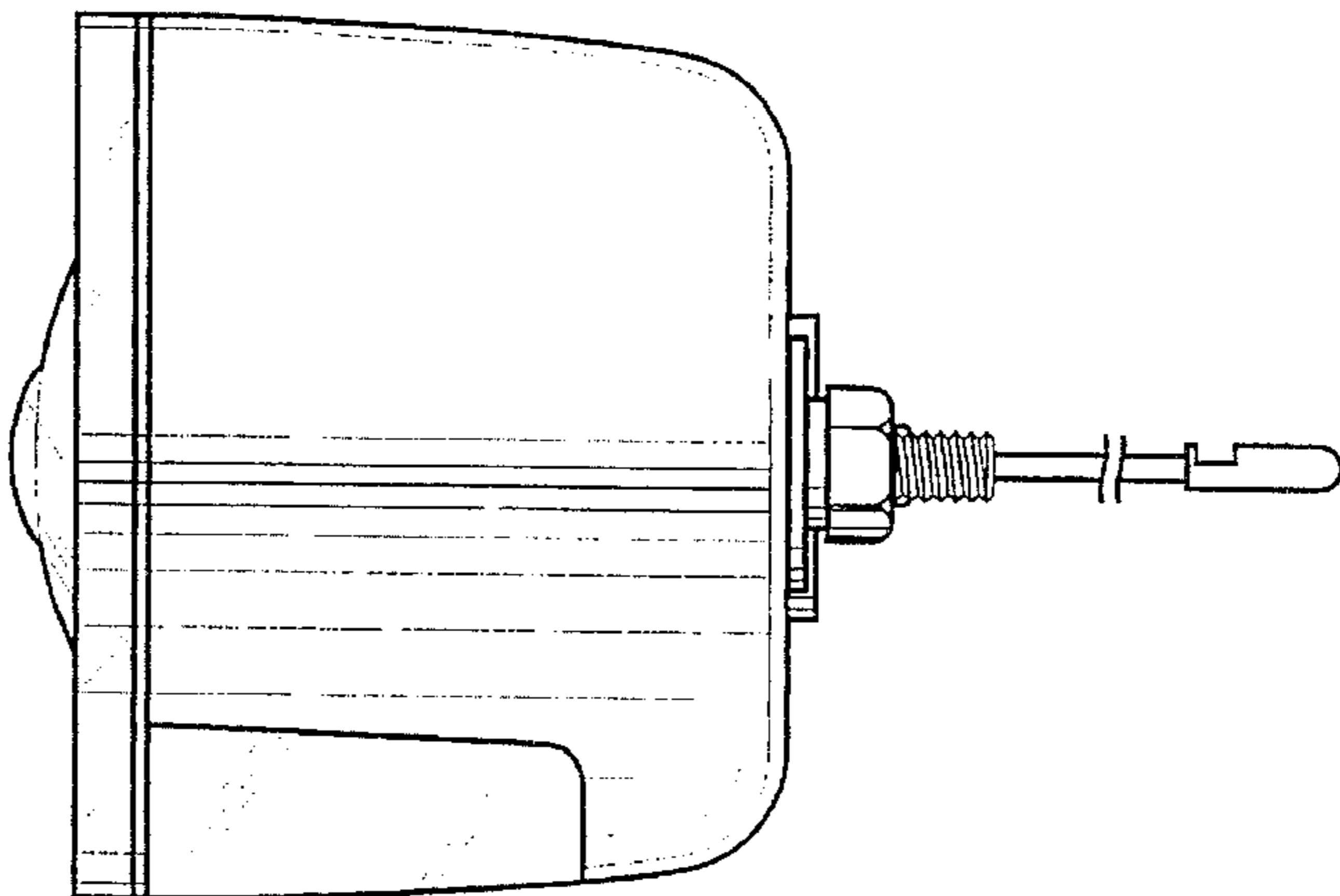
**FIG.1**

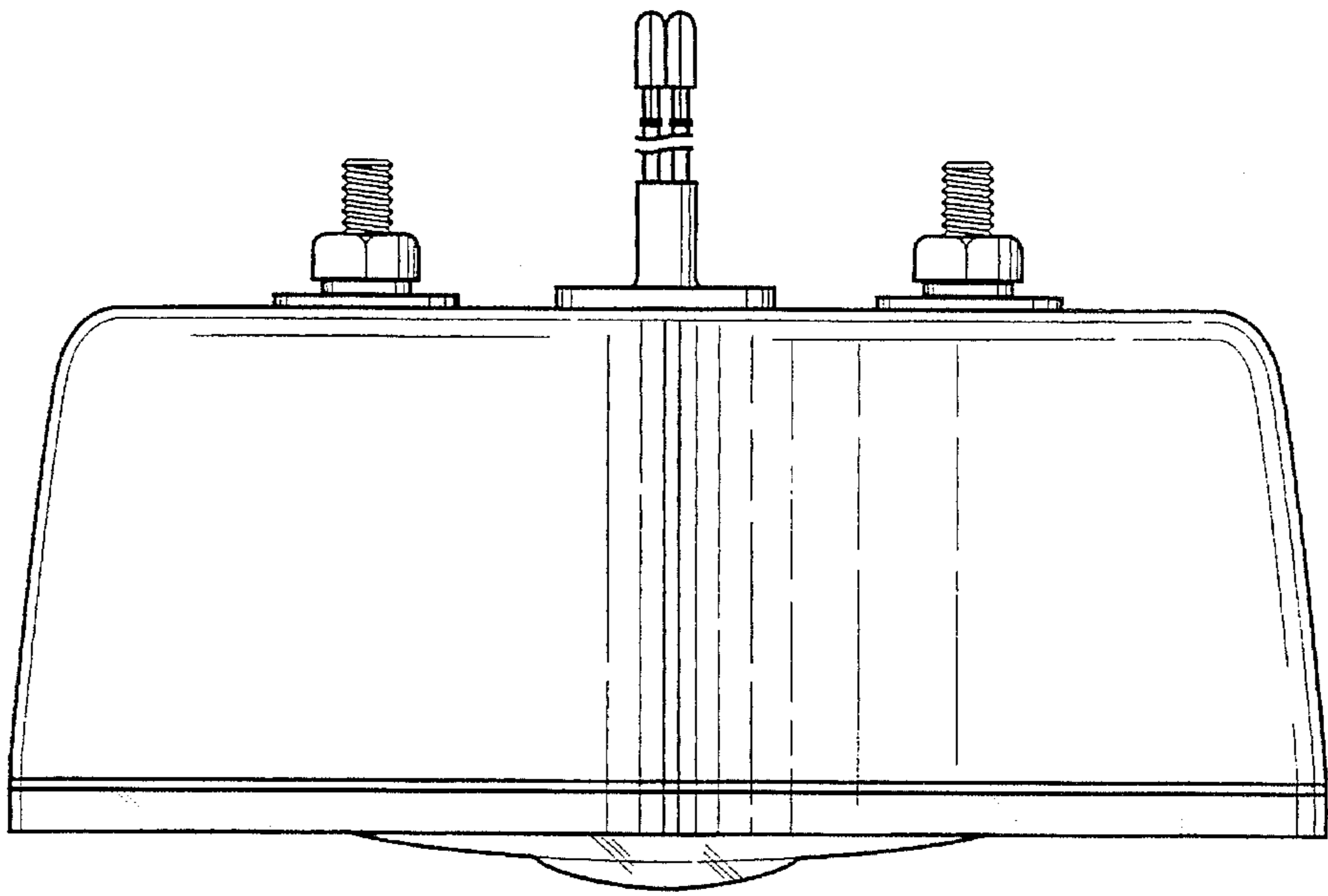


**FIG.2**



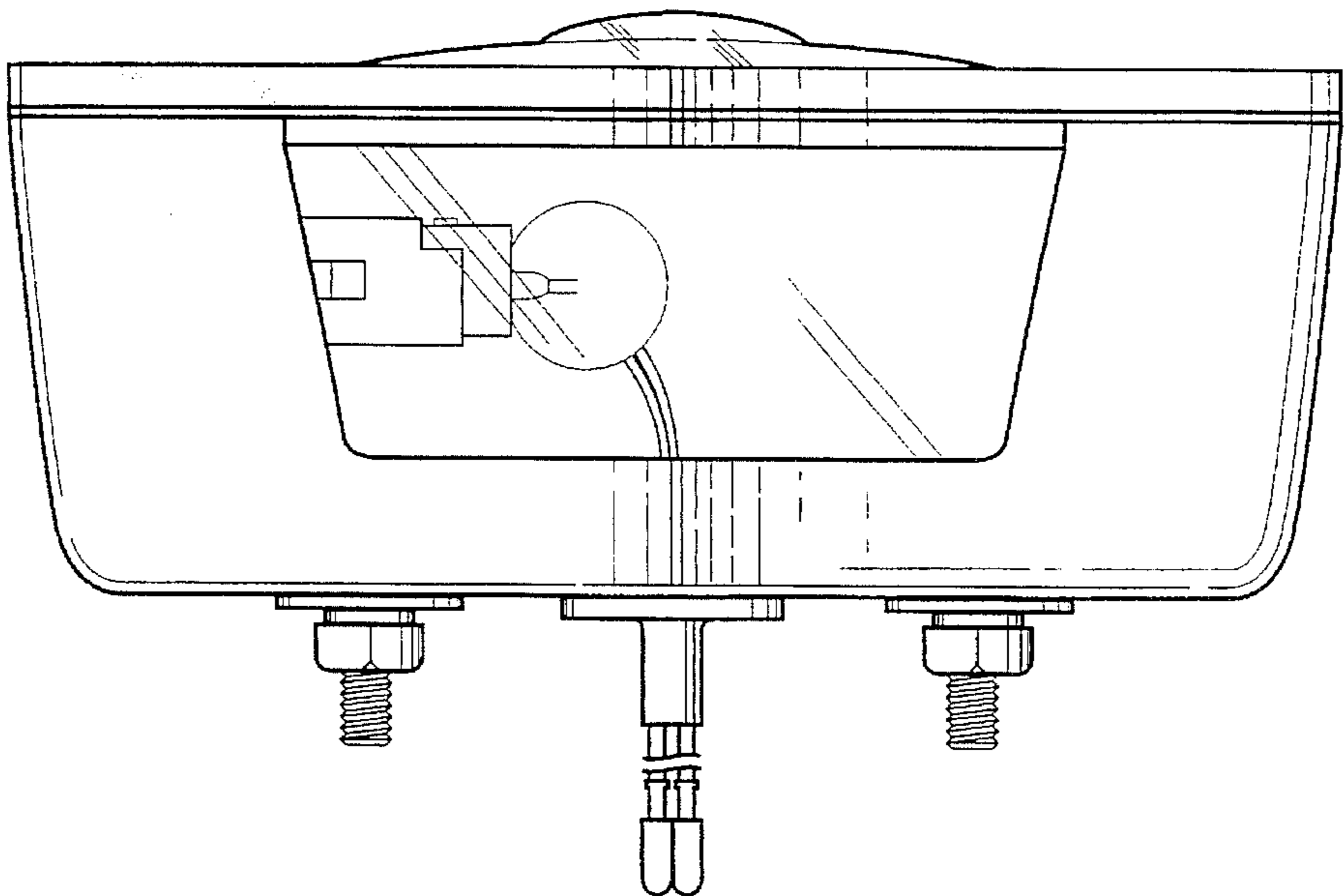
**FIG.3**





**FIG.4**

**FIG.5**



**FIG.6**

