



US00D372255S

United States Patent [19] Nakamura

[11] Patent Number: **Des. 372,255**
[45] Date of Patent: ****Jul. 30, 1996**

[54] VIDEO CAMERA WITH LIQUID CRYSTAL MONITOR AND VIDEO TAPE RECORDER

[75] Inventor: **Makoto Nakamura**, Kyoto, Japan
[73] Assignee: **Matsushita Electric Industrial Co., Ltd.**, Osaka, Japan
[**] Term: **14 Years**

[21] Appl. No.: **44,248**
[22] Filed: **Sep. 21, 1995**

[30] Foreign Application Priority Data

Mar. 22, 1995 [JP] Japan 7-7832

[52] U.S. Cl. **D16/202**

[58] Field of Search D16/200-206,
D16/208; 348/143, 373-376; 352/242, 243;
354/81, 82, 288; 358/906; H04N 5/225

[56] References Cited

U.S. PATENT DOCUMENTS

D. 342,752 12/1993 Urushihara et al. D16/202
D. 345,172 3/1994 Ishikawa D16/202
D. 356,806 3/1995 Kim D16/202
D. 356,807 3/1995 Sato et al. D16/202
4,772,902 9/1988 Inoue et al. 354/82

FOREIGN PATENT DOCUMENTS

4-84571 3/1992 Japan H04N 5/225

OTHER PUBLICATIONS

Panasonic Leaflet issued May, 1994 (6 pages).
Sharp's Leaflet issued Sep., 1993 (4 pages).
Sony's leaflet issued Feb., 1994, (6 pages).
Video Magazine, Jan. 1993 p. 28 (Minolta's master 8-848).

Primary Examiner—Ted Shooman
Assistant Examiner—Adir Aronovich
Attorney, Agent, or Firm—Sughrue, Mion, Zinn, Macpeak & Seas

[57] CLAIM

The ornamental design for a video camera with liquid crystal monitor and video tape recorder, as shown and described.

DESCRIPTION

FIG. 1 is a perspective view of the top, front and right side of a video camera with liquid crystal monitor and video tape recorder showing my new design;
FIG. 2 is a front elevational view thereof;
FIG. 3 is a rear elevational view thereof;
FIG. 4 is a top plan view thereof;
FIG. 5 is a bottom plan view thereof;
FIG. 6 is a left side elevational view thereof;
FIG. 7 is a right side elevational view thereof; and,
FIG. 8 is a perspective view of the top, rear and right side thereof with the liquid crystal monitor in the open position.

1 Claim, 5 Drawing Sheets

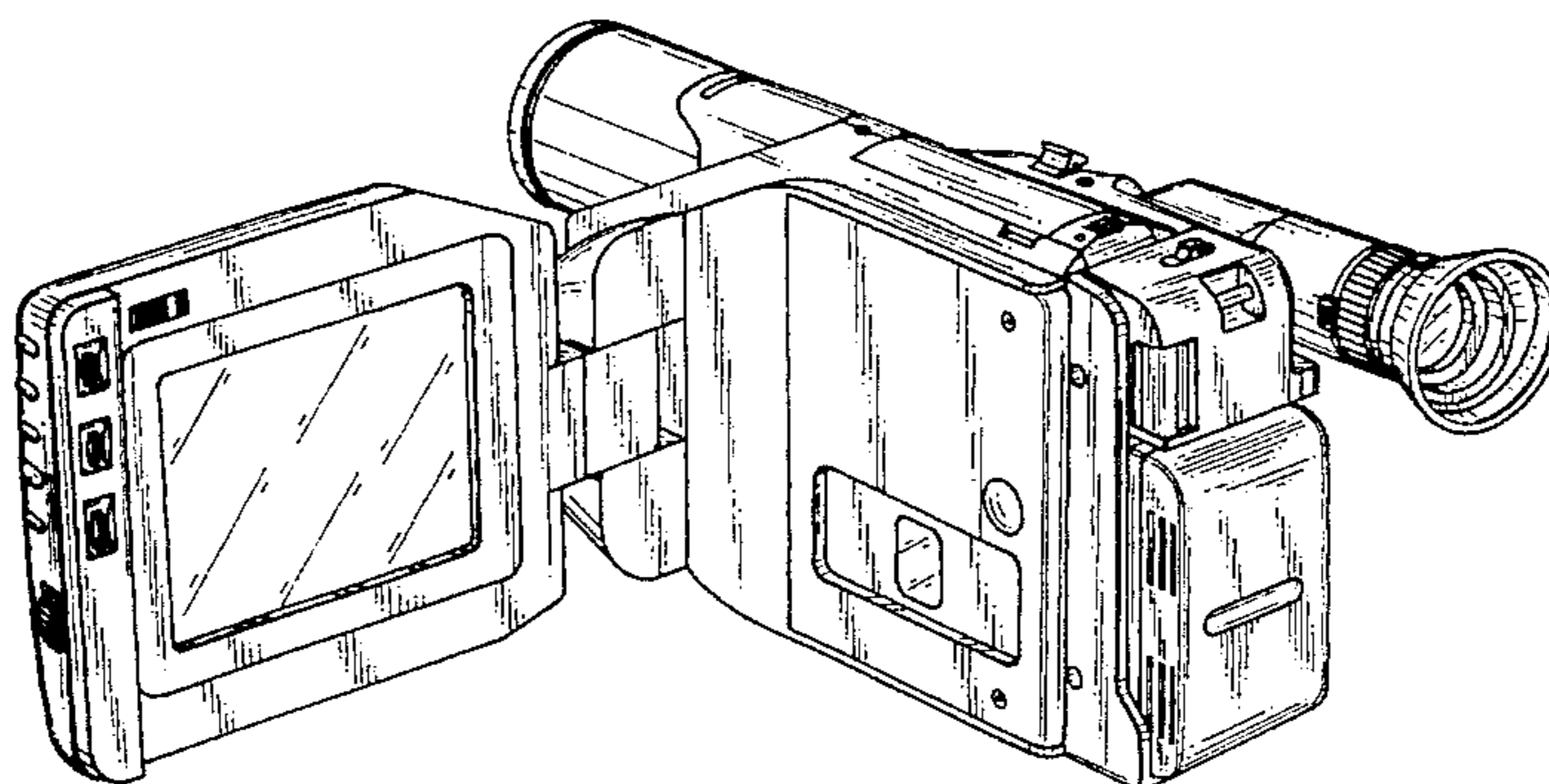
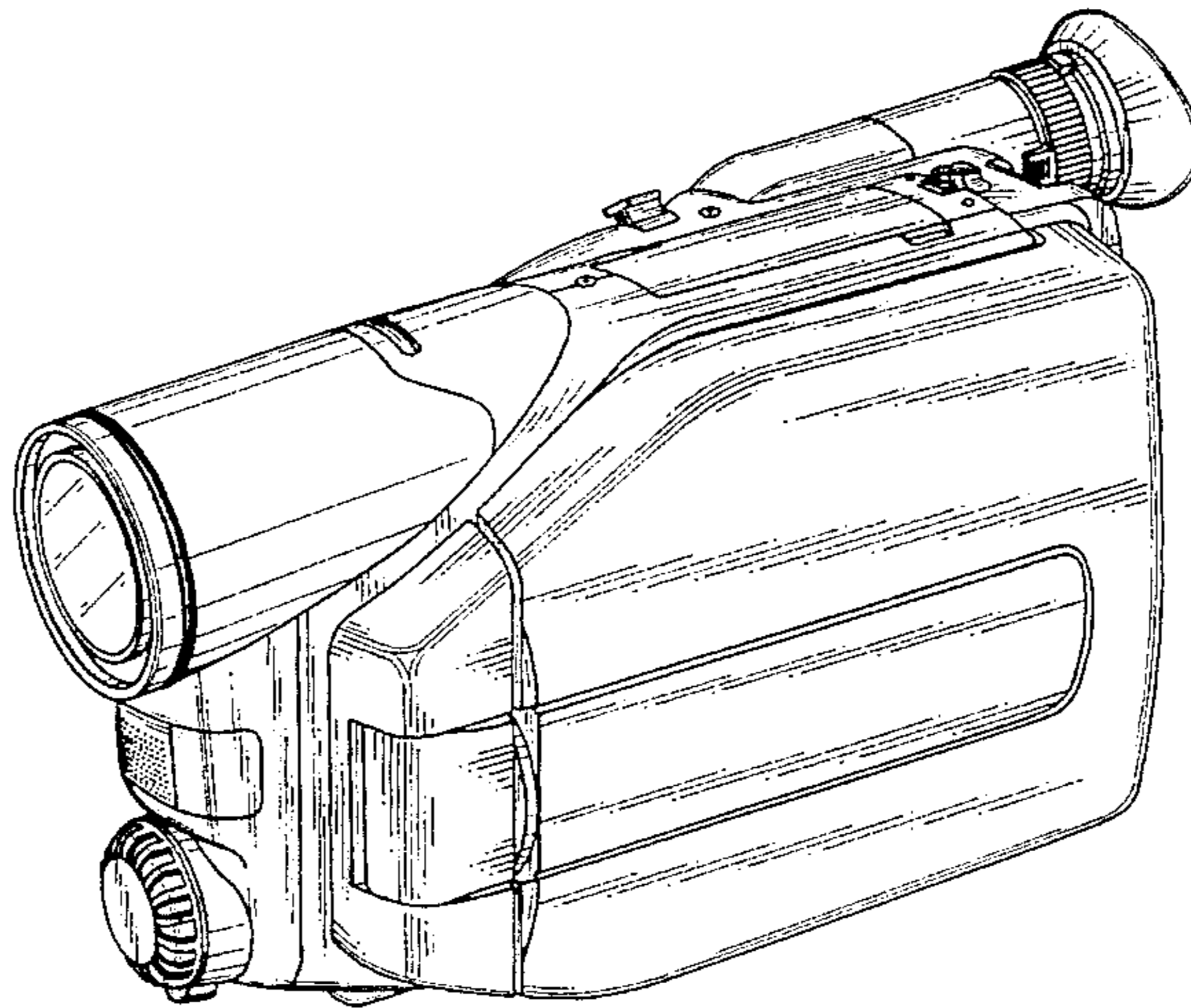

Fig. 1

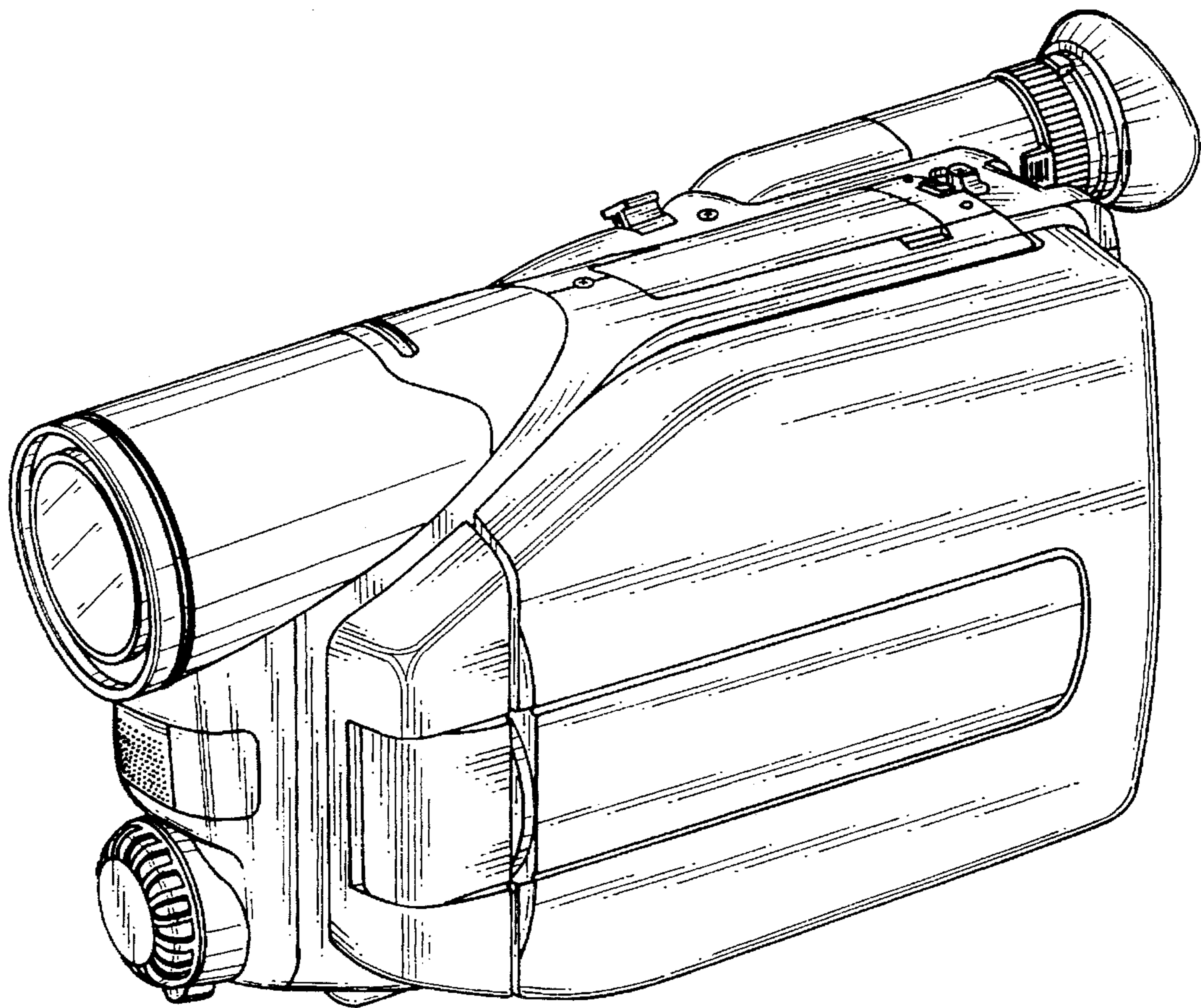

Fig. 2

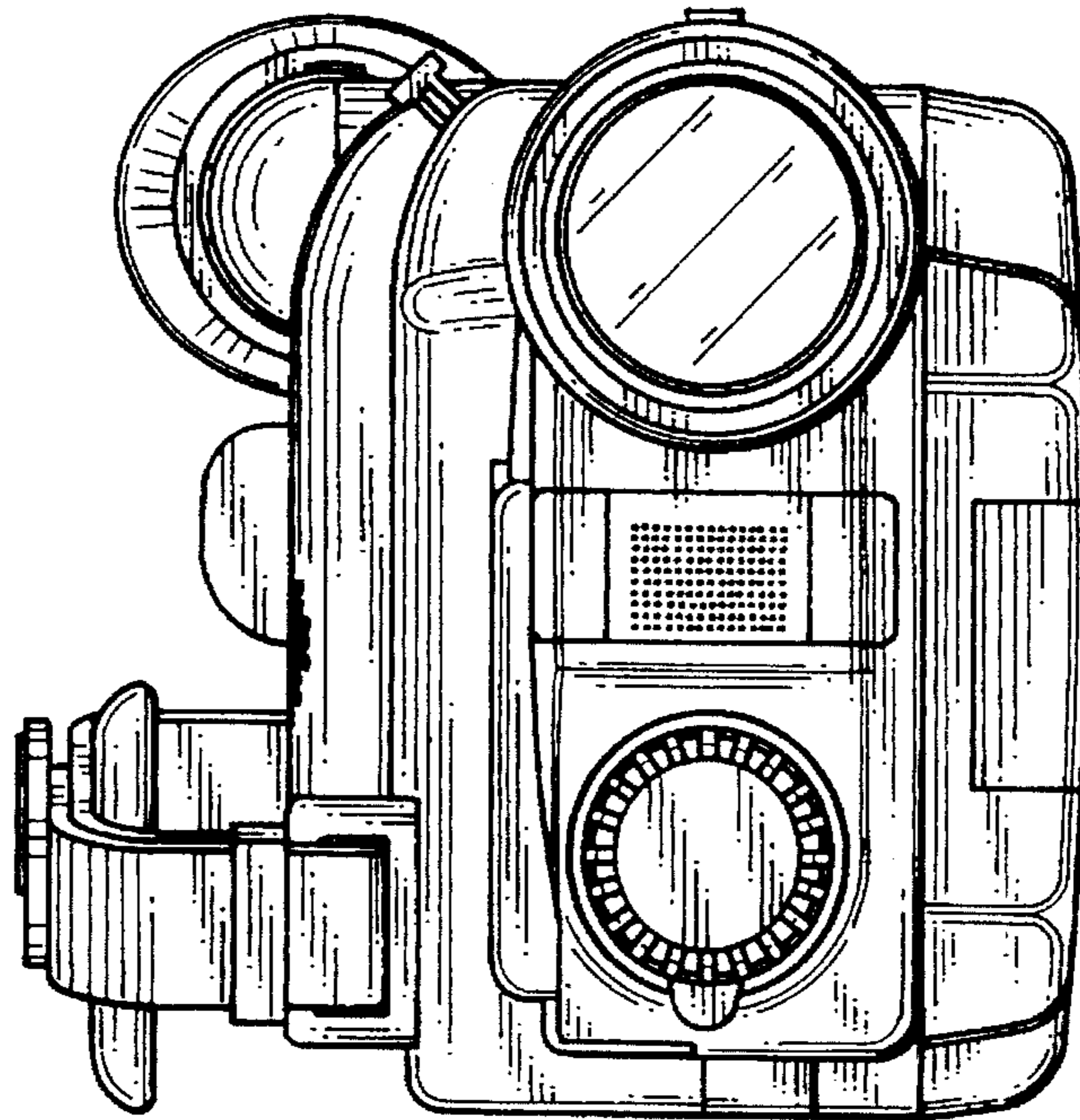

Fig. 3

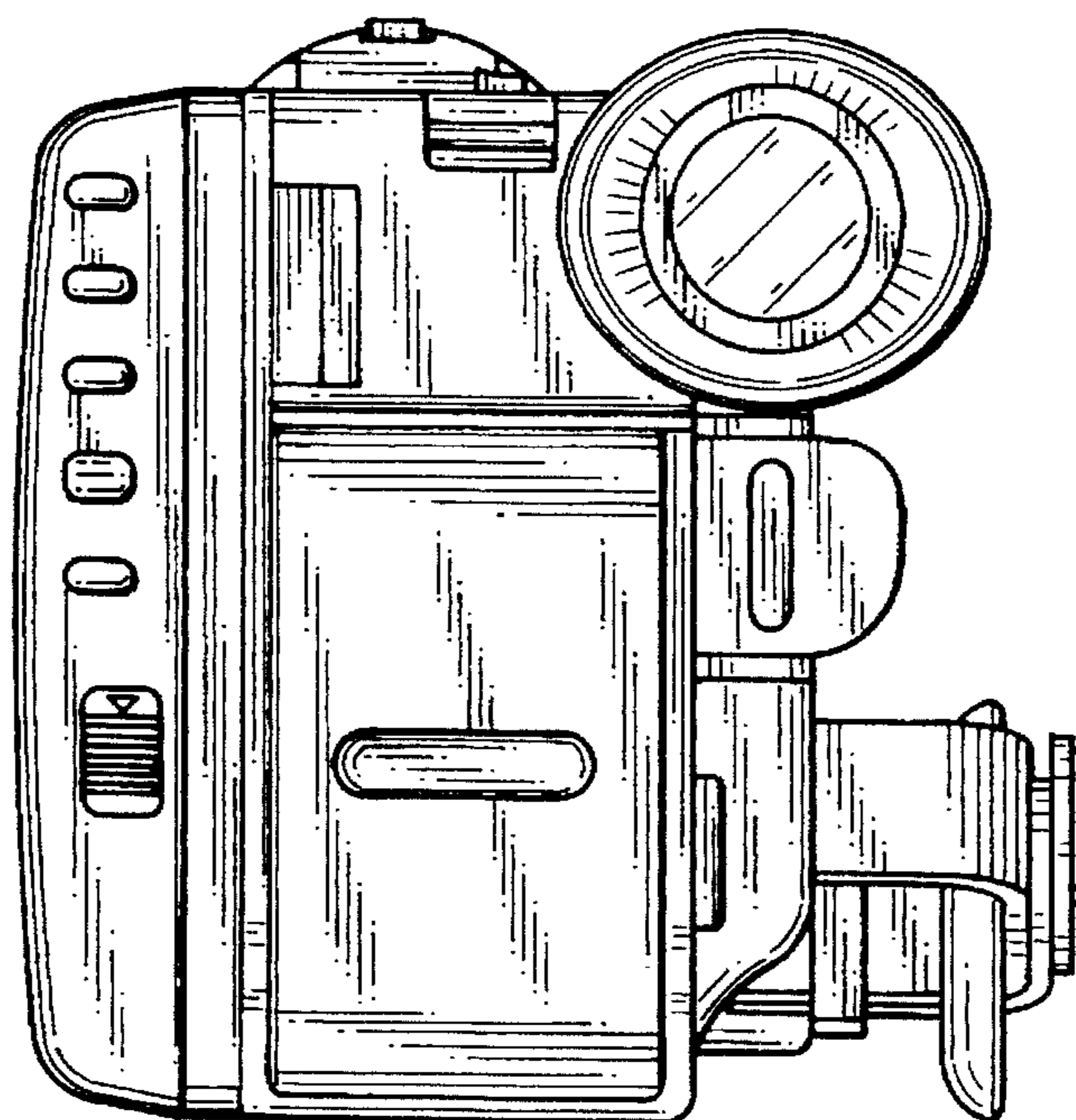

Fig. 4

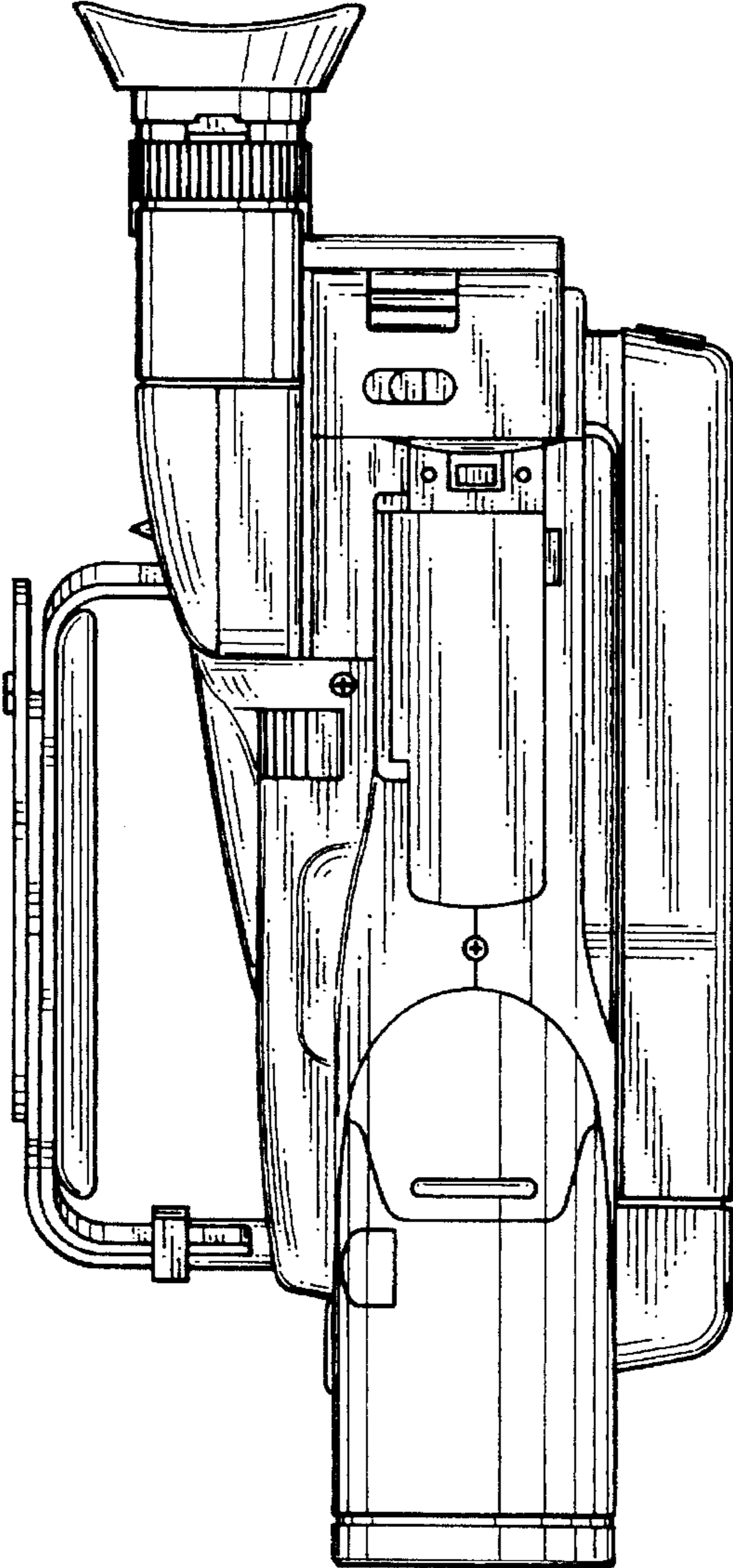

Fig. 5

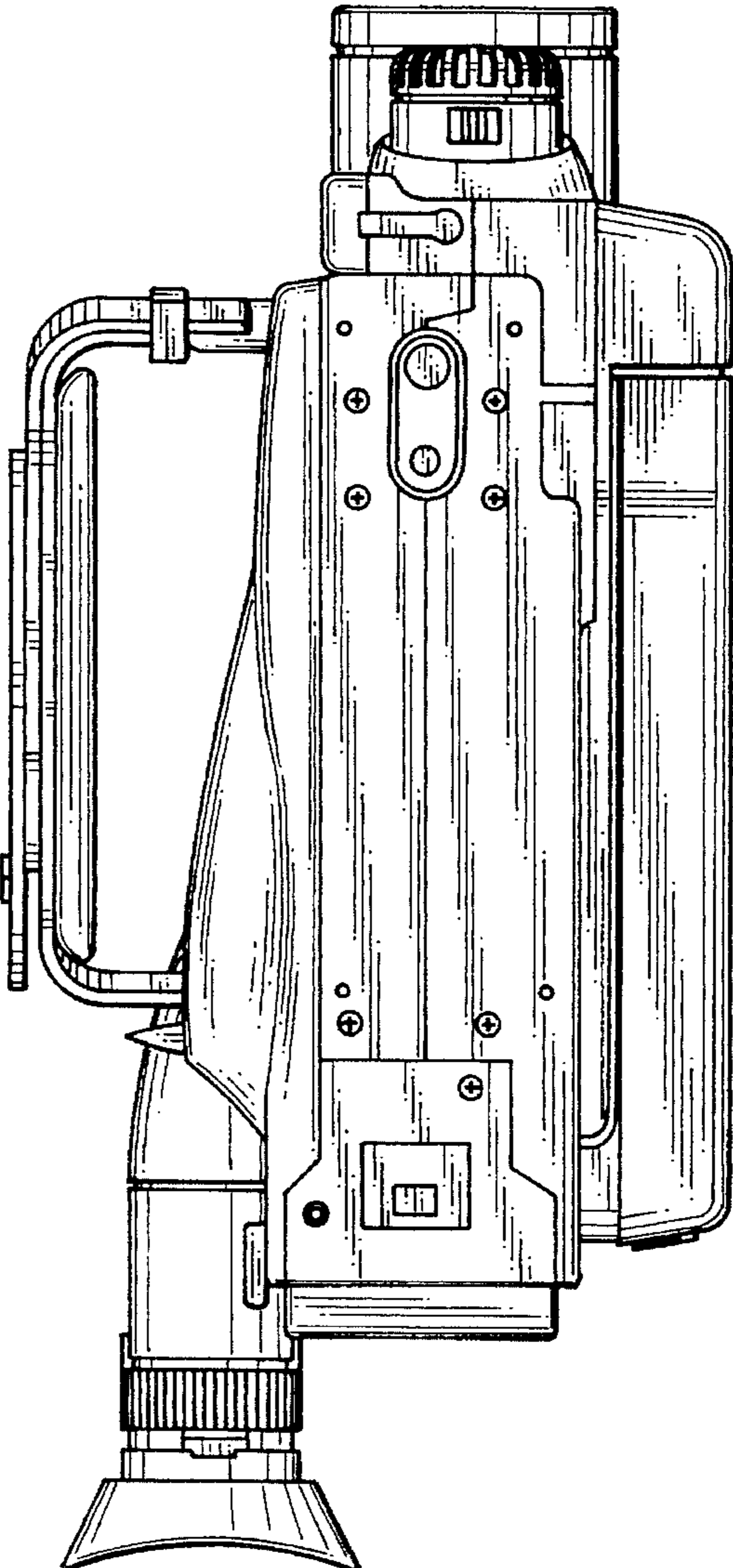

Fig. 6

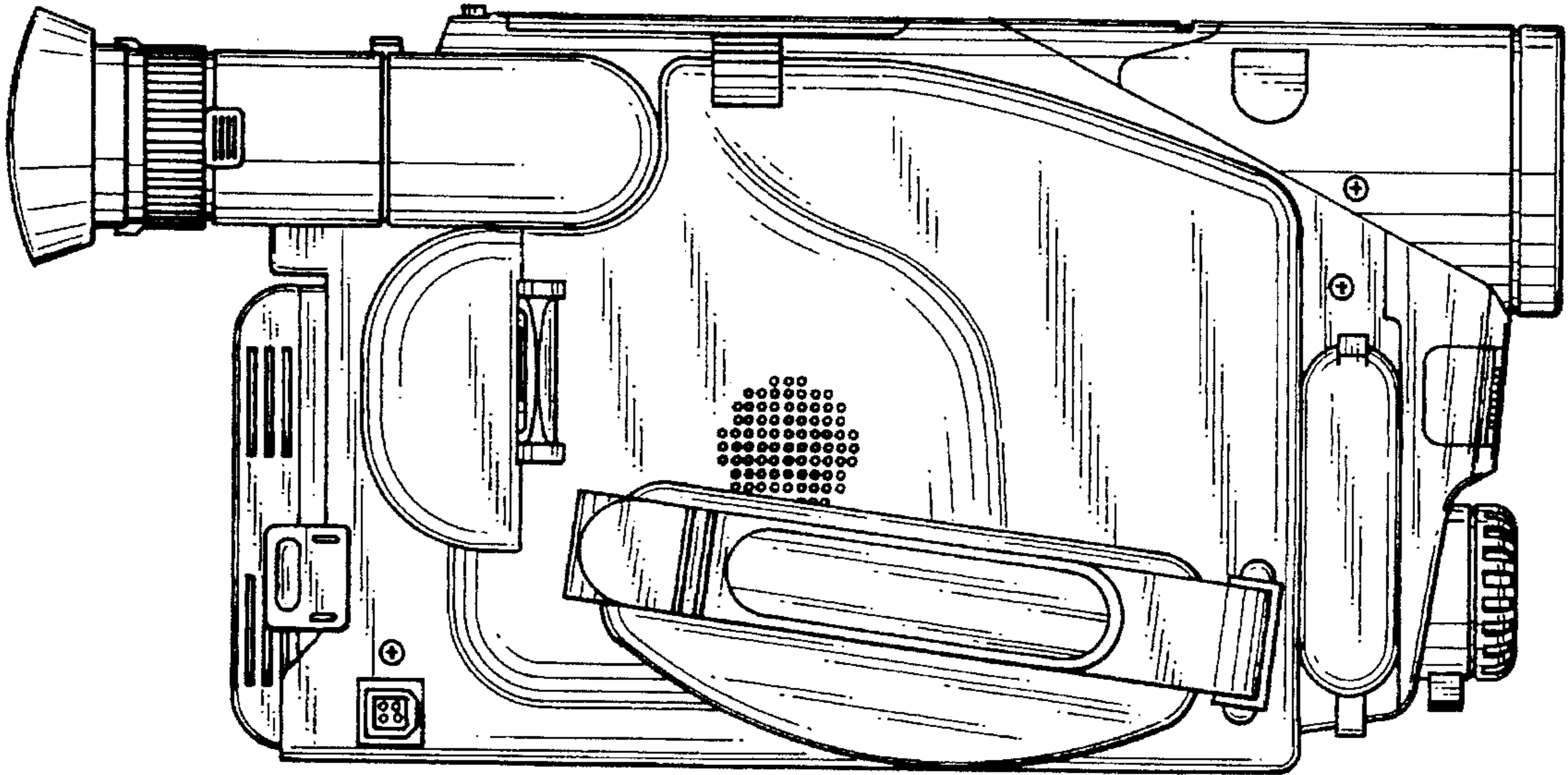

Fig. 7

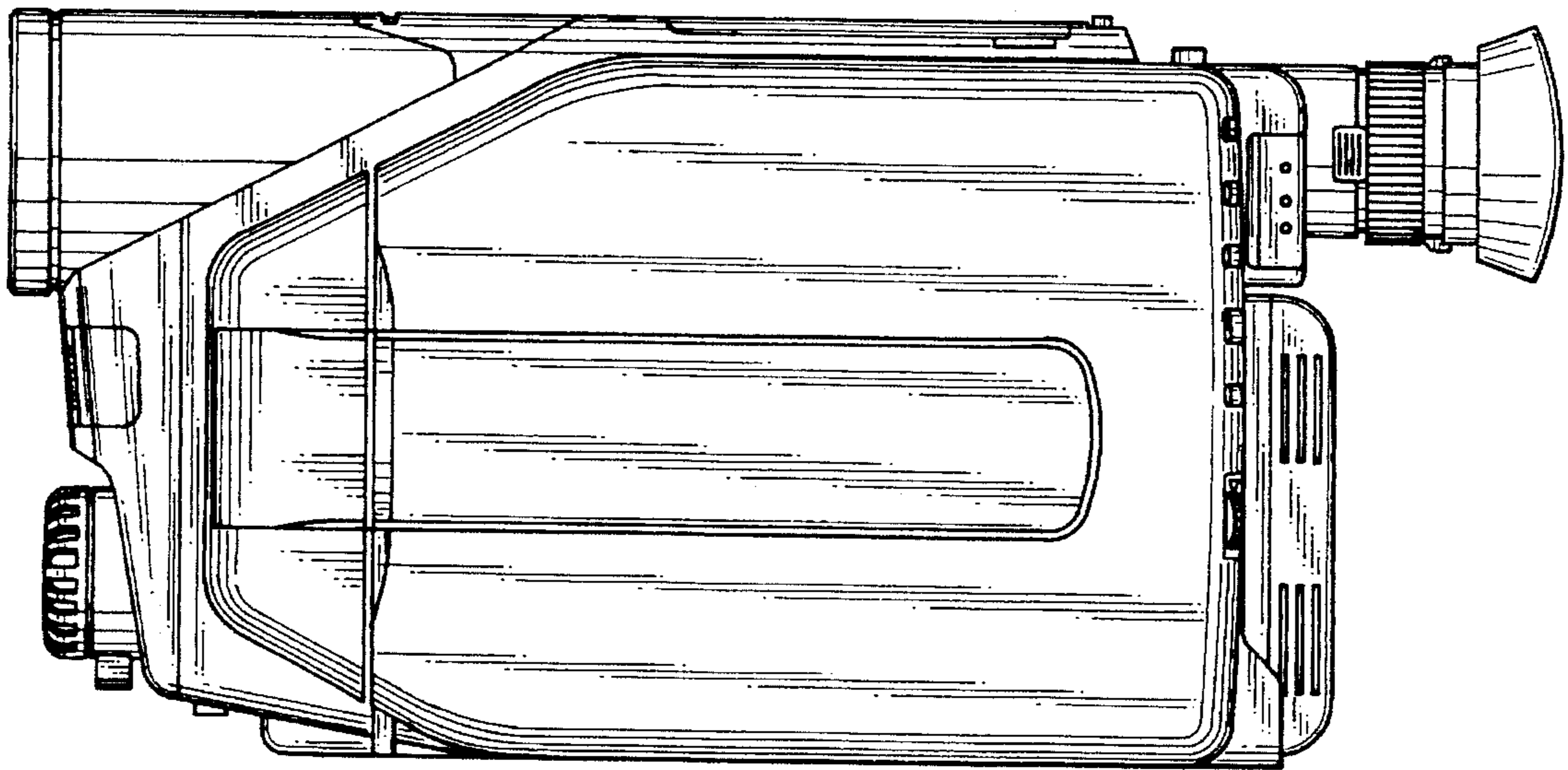

Fig. 8

