



US00D372216S

United States Patent [19]

[11] Patent Number: **Des. 372,216**

Denson et al.

[45] Date of Patent: ****Jul. 30, 1996**

[54] **BULLET RESISTANT AUTOMOBILE SHIELD**

Attorney, Agent, or Firm—Harpman & Harpman

[76] Inventors: **Richard E. Denson; Shirley A. Denson**, both of 508 S. Smithville Rd., Dayton, Ohio 45403

[57] **CLAIM**

The ornamental design for a bullet resistant automobile shield, as shown and described.

[**] Term: **14 Years**

DESCRIPTION

[21] Appl. No.: **38,173**

[22] Filed: **Apr. 28, 1995**

[52] U.S. Cl. **D12/183**

[58] Field of Search D12/183; 296/152, 296/97.1, 97.2; 276/39.1

FIG. 1 is a front, top and side perspective view of the bullet resistant automobile shield embodying the design of the present invention;

FIG. 2 is a front elevational view thereof;

FIG. 3 is a rear elevational view thereof;

FIG. 4 is a side elevational view thereof, the side opposite being a mirror image of the side shown in FIG. 4;

FIG. 5 is a top plan view thereof; and,

FIG. 6 is a bottom plan view thereof.

[56] **References Cited**

U.S. PATENT DOCUMENTS

| | | | | |
|------------|--------|-------------|-------|-----------|
| D. 337,297 | 7/1993 | Johnson | | D12/183 |
| 4,907,836 | 3/1990 | Ueda et al. | | 296/152 X |
| 4,943,103 | 7/1990 | Rosen | | 296/152 X |

OTHER PUBLICATIONS

"A Manual of Engineering Drawing" —1935.

Primary Examiner—Alan P. Douglas

Assistant Examiner—S. Snapp

1 Claim, 3 Drawing Sheets

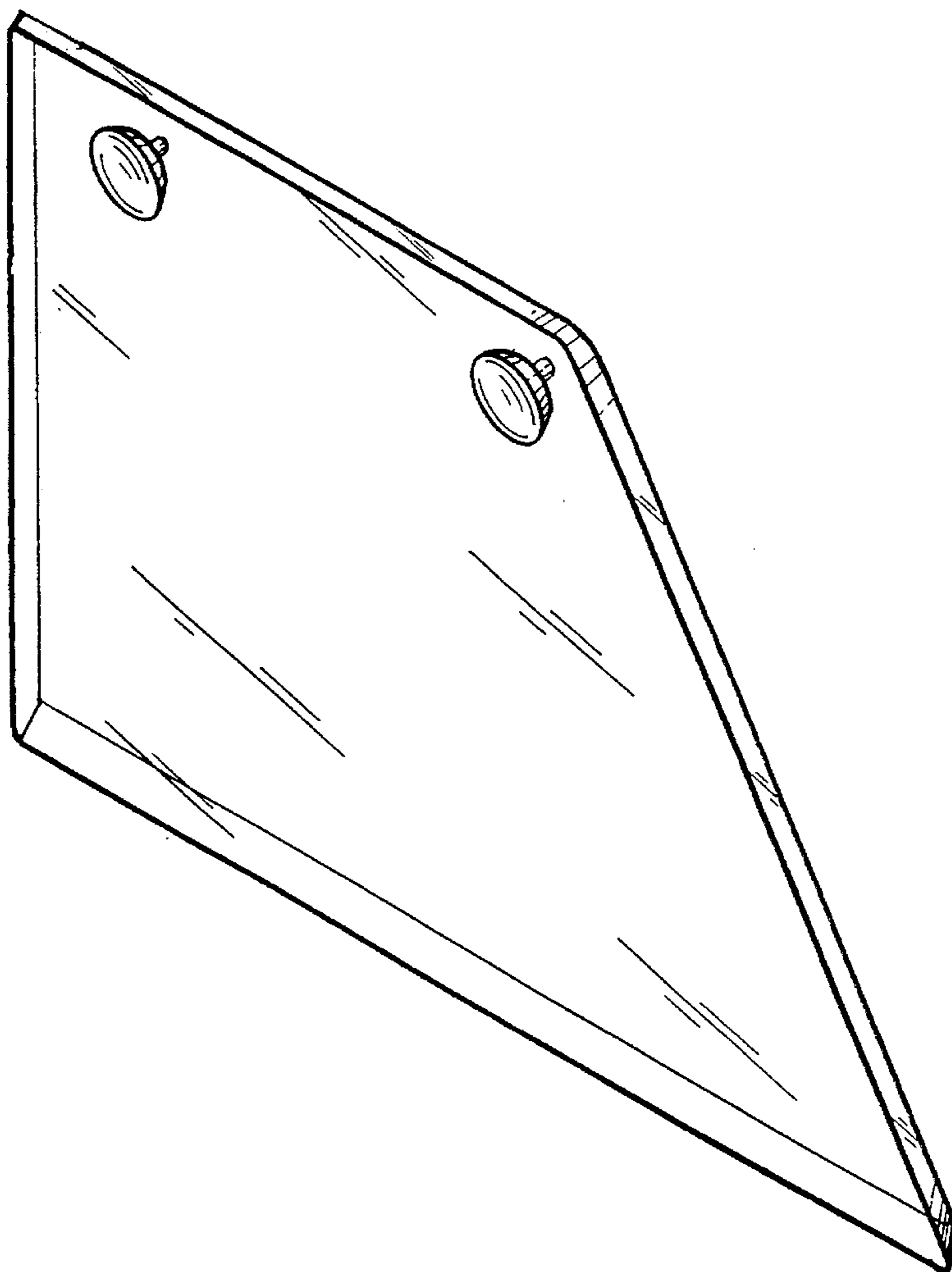

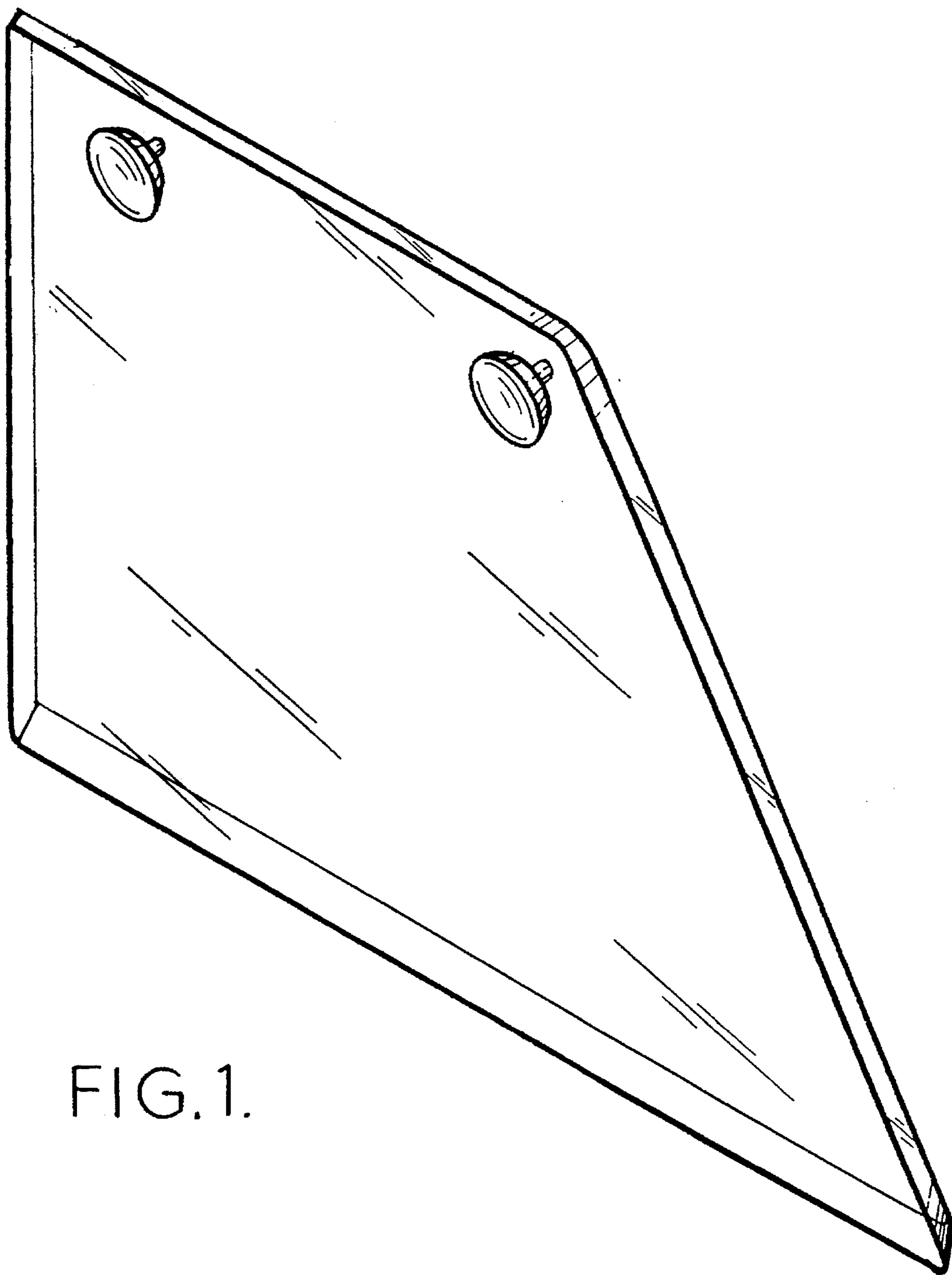

FIG. 1.

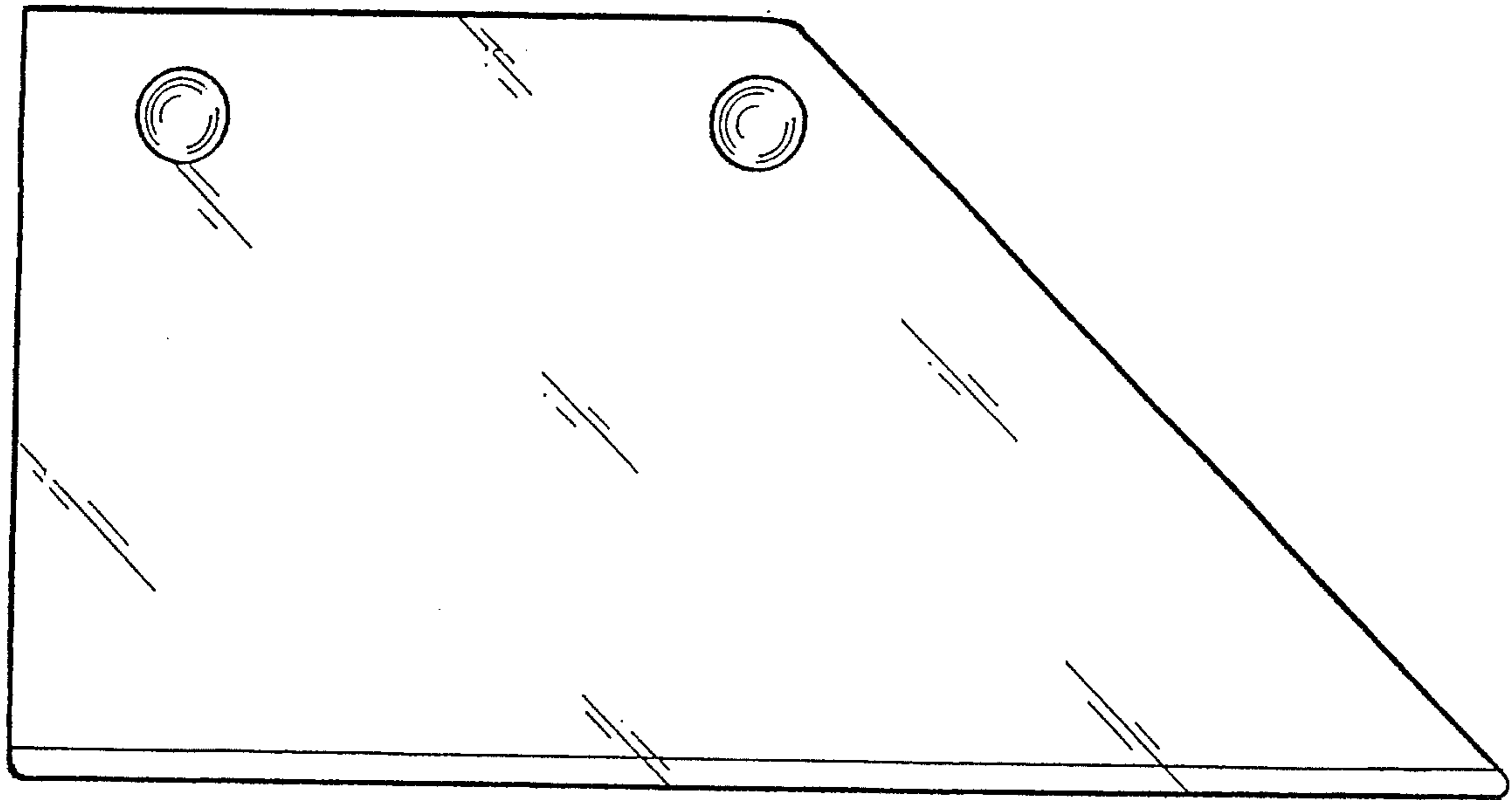

FIG. 2.



FIG. 5.



FIG. 4.

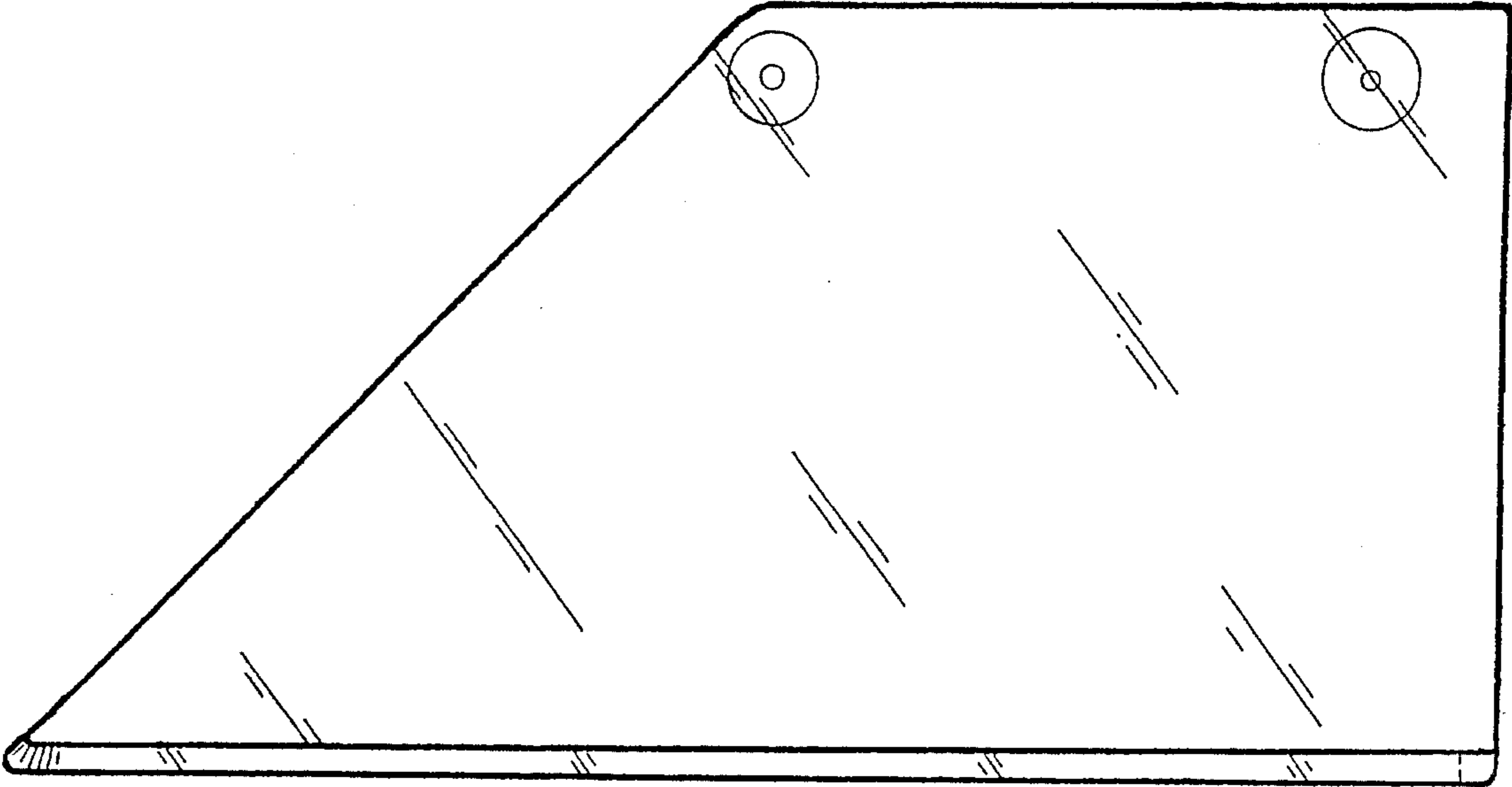

FIG. 3.

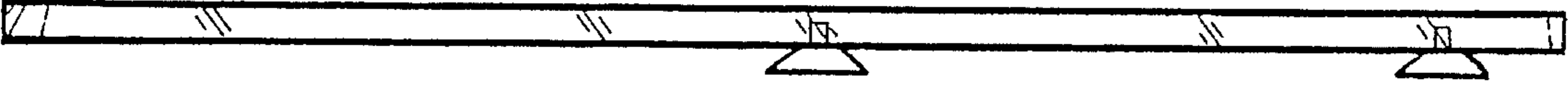

FIG 6.