



US00D372143S

# United States Patent [19] Selby

[11] Patent Number: **Des. 372,143**

[45] Date of Patent: **\*\*Jul. 30, 1996**

[54] **CARRIER RACK**

[76] Inventor: **Harold E. Selby**, 5 S. 5th St.,  
Marshalltown, Iowa 50158

[\*\*] Term: **14 Years**

[21] Appl. No.: **38,836**

[22] Filed: **May 15, 1995**

[52] U.S. Cl. .... **D6/468**; D3/315; D6/462

[58] Field of Search ..... D6/462-468, 429-431,  
D6/409-411; D3/315, 260; D22/147; D21/223;  
D19/83-85; 211/60.1, 70.8, 70.2, 198, 195,  
208, 175, 182, 71; 294/143, 159, 161; 224/922;  
248/97, 99

[56] **References Cited**

**U.S. PATENT DOCUMENTS**

D. 155,792	11/1949	Ferris	.....	D6/468
D. 195,262	5/1963	Crawford	.....	D6/467
D. 250,303	11/1978	Haber	.....	D6/468
D. 269,751	7/1983	Rieman	.....	D6/467
D. 272,944	3/1984	Coughlin	.....	D6/463
D. 278,490	4/1985	Stevens	.....	D6/462
D. 324,541	3/1992	Dudley	.....	D3/315 X
D. 337,007	7/1993	Hanson	.....	D6/462
D. 341,730	11/1993	Sampson et al.	.....	D6/468 X
D. 364,516	11/1995	Helenowski	.....	D6/462
2,987,109	6/1961	Sohmer	.....	294/143
2,990,865	7/1961	Steele	.....	211/70.2
3,094,216	6/1963	Gordon	.....	D6/410 X

3,215,181	11/1965	Reed	.....	294/159 X
4,036,416	7/1977	Lowe	.....	211/70.2
4,684,091	8/1987	Moreschi	.....	211/182 X
4,691,832	9/1987	Steiger	.....	211/71
4,696,122	9/1987	Van Der zyl	.....	294/143 X
4,779,914	10/1988	Friedline	.....	211/70.8 X
5,005,847	4/1991	King et al.	.....	D3/315 X
5,096,072	3/1992	Link	.....	211/195 X

**OTHER PUBLICATIONS**

Sears Boating, p. 23 Item 10.  
Making Plastic Pipe Furniture, p. 52, Night Table and Coffee  
Table.

*Primary Examiner*—Jeffrey Asch

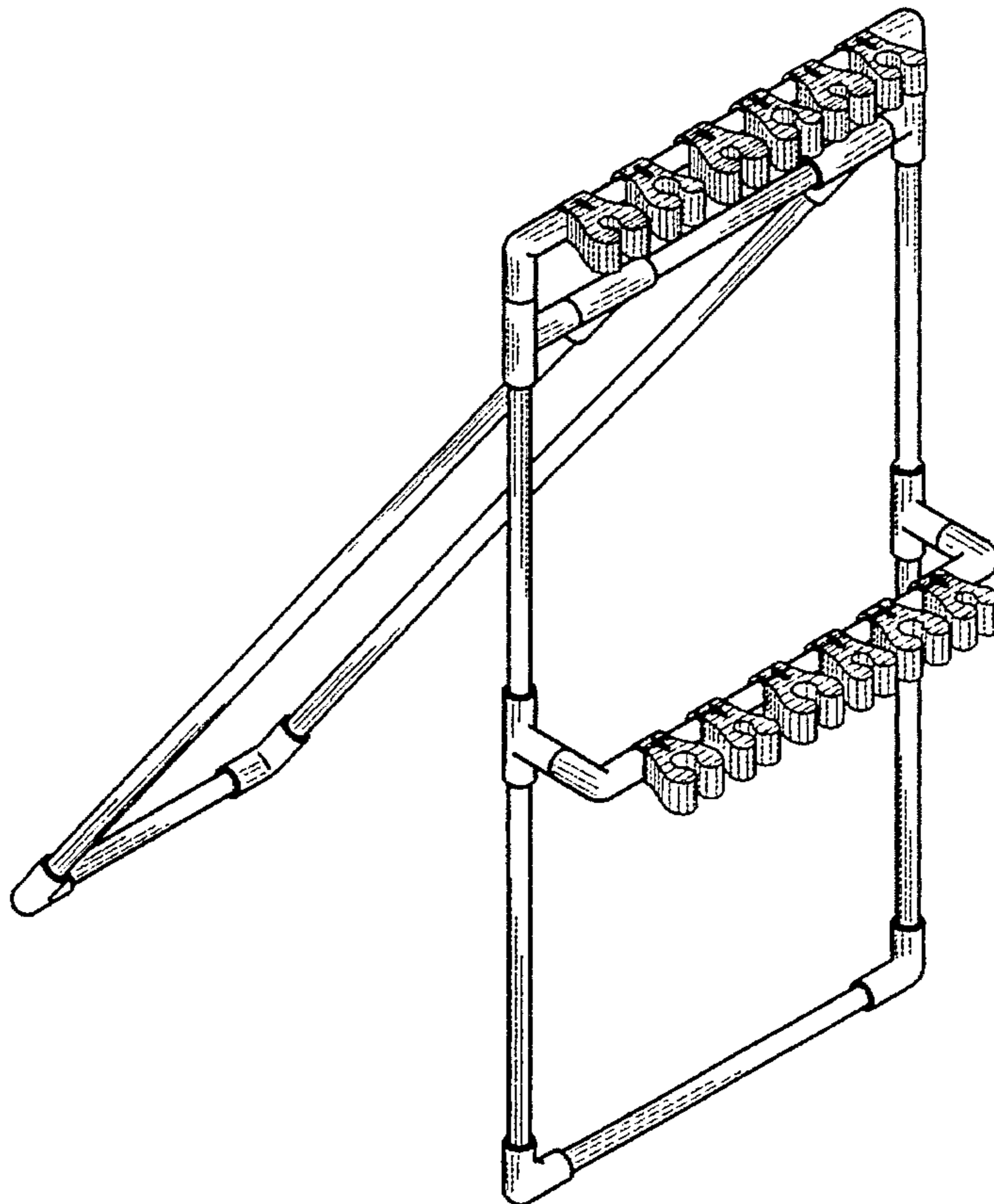
[57] **CLAIM**

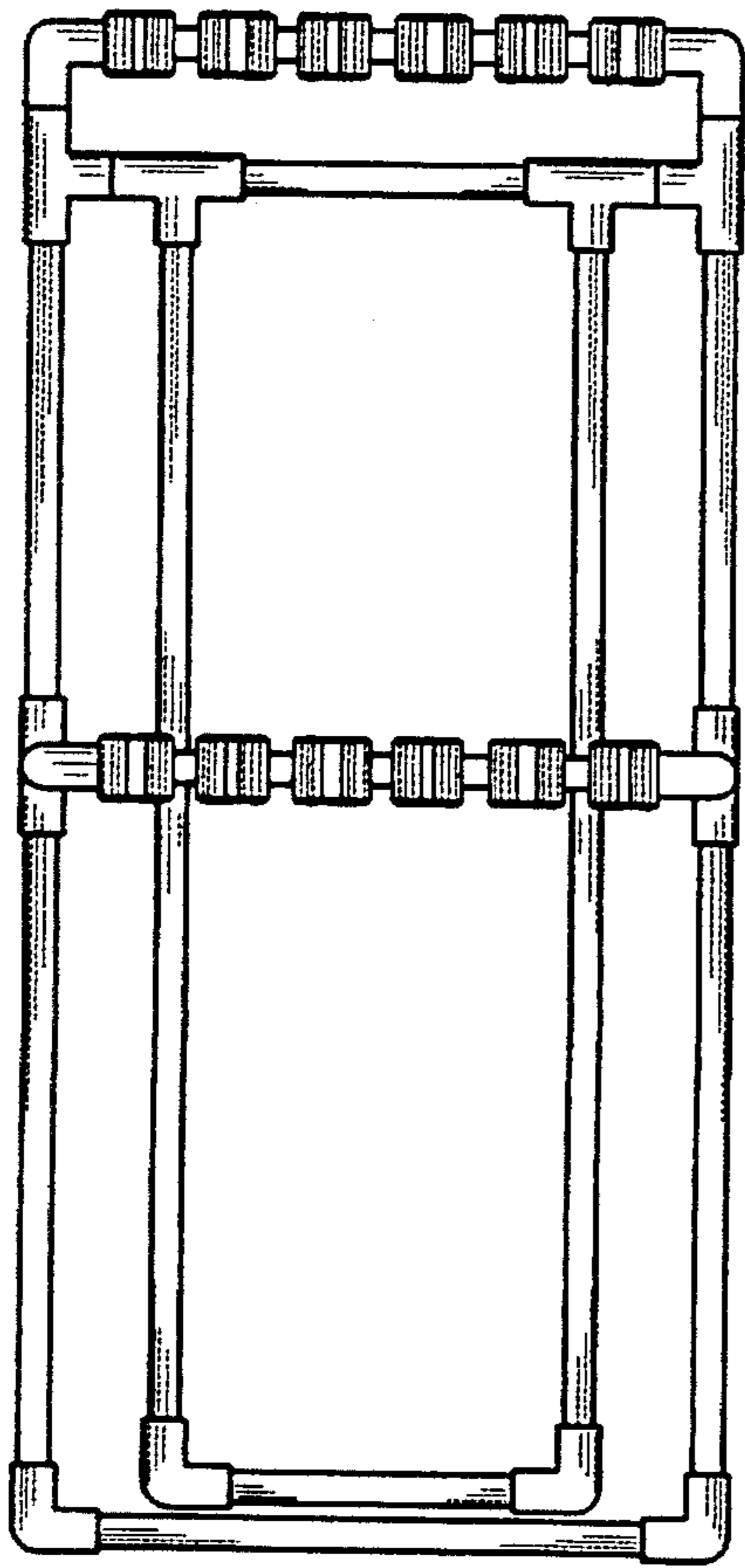
The ornamental design of a carrier rack, as shown and  
described.

**DESCRIPTION**

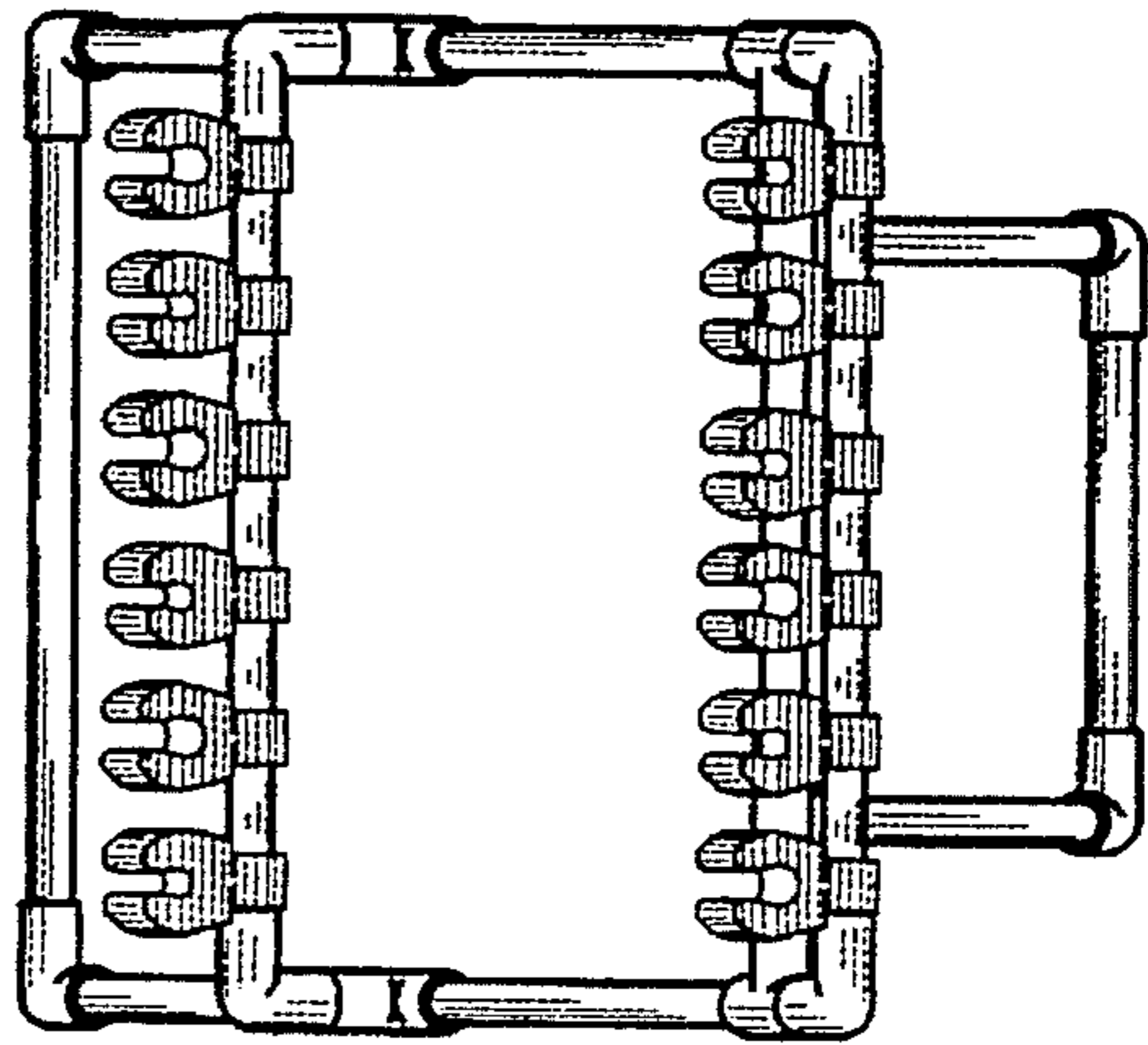
FIG. 1 is a front view of the carrier rack showing my new  
design in folded condition;  
FIG. 2 is a top view thereof;  
FIG. 3 is a bottom thereof;  
FIG. 4 is a front view thereof;  
FIG. 5 is a rear view thereof;  
FIG. 6 is a side perspective view thereof; and,  
FIG. 7 is an end view thereof.

**1 Claim, 3 Drawing Sheets**

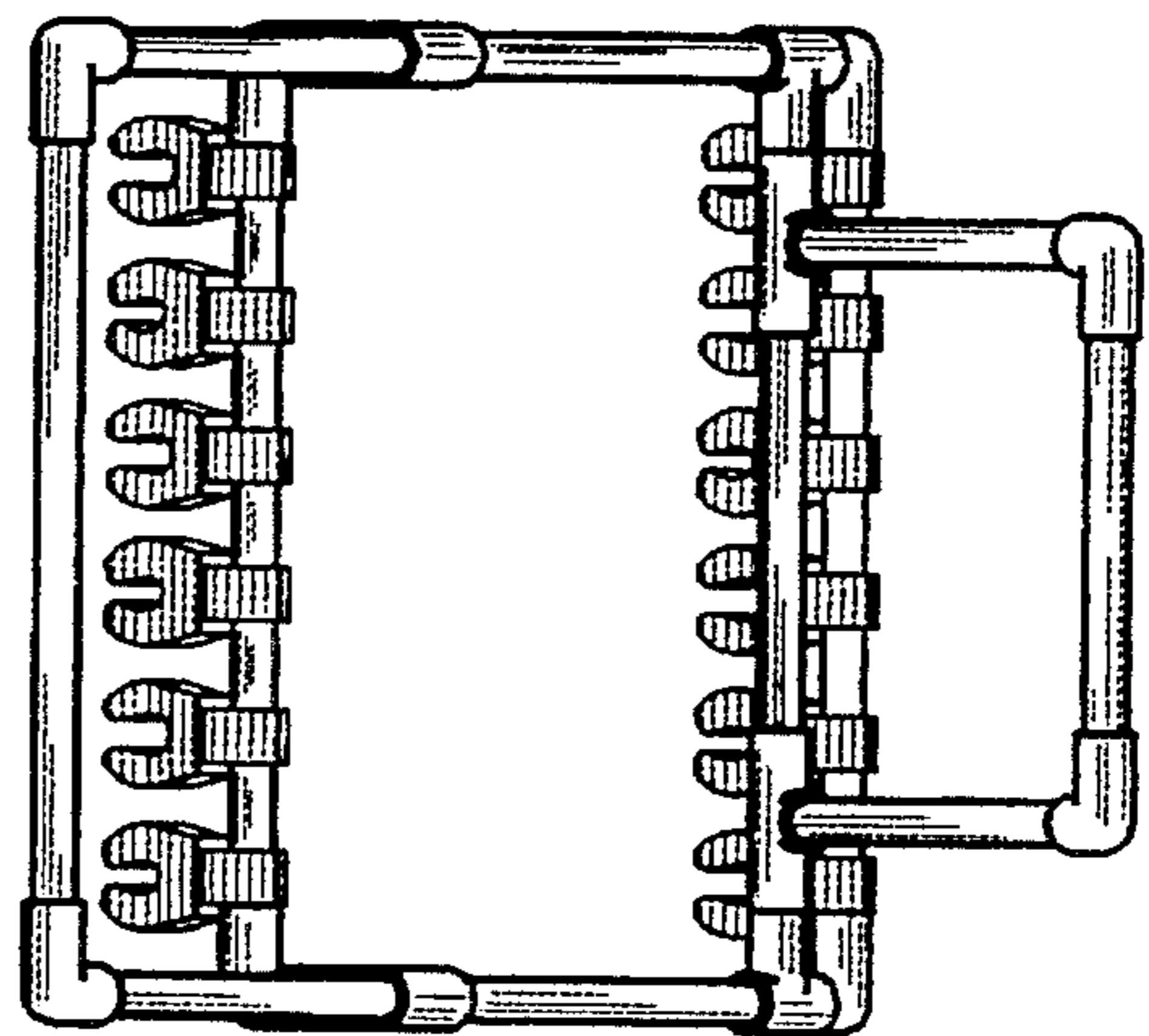




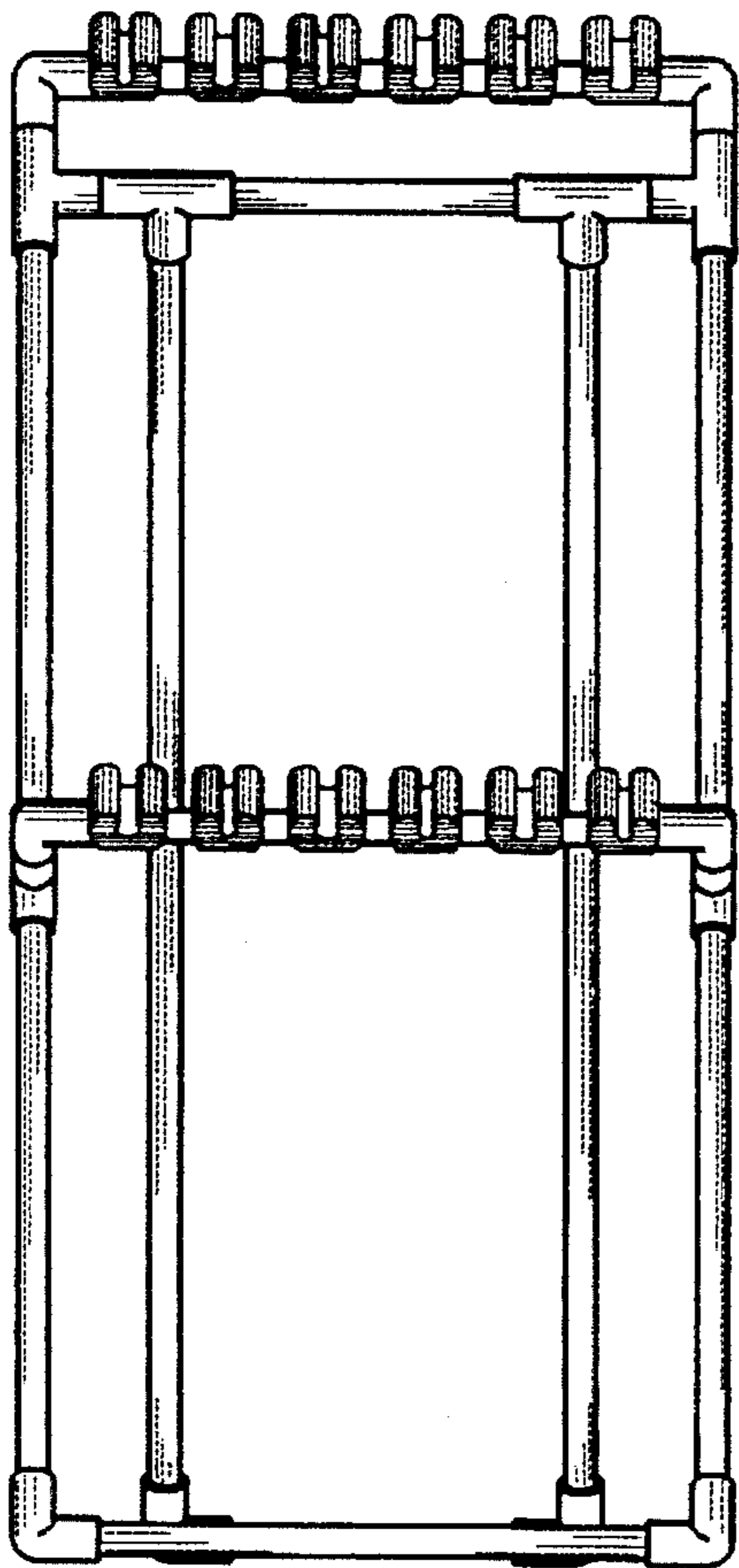
*FIG. 1*



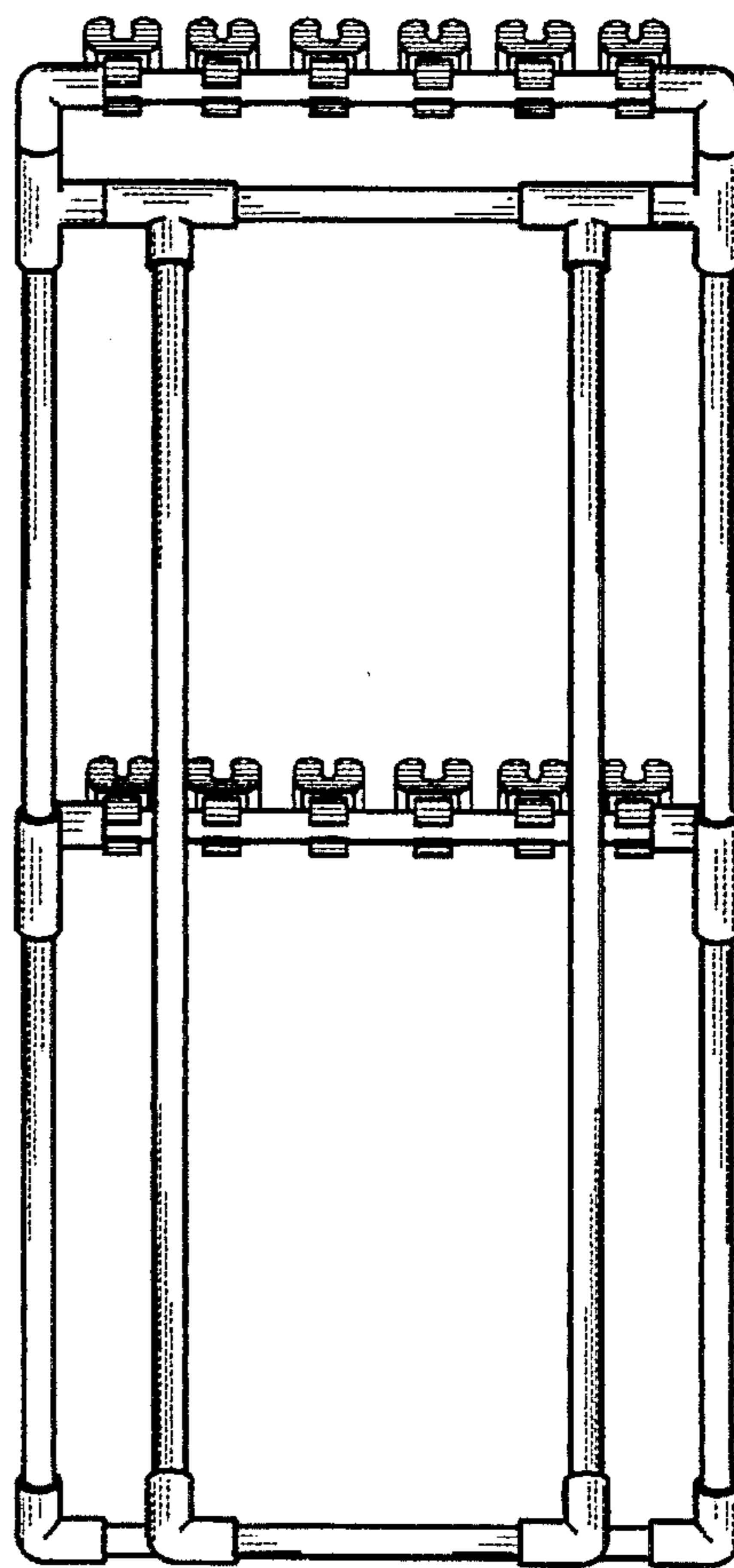
*FIG. 2*



*FIG. 3*



*FIG. 4*



*FIG. 5*

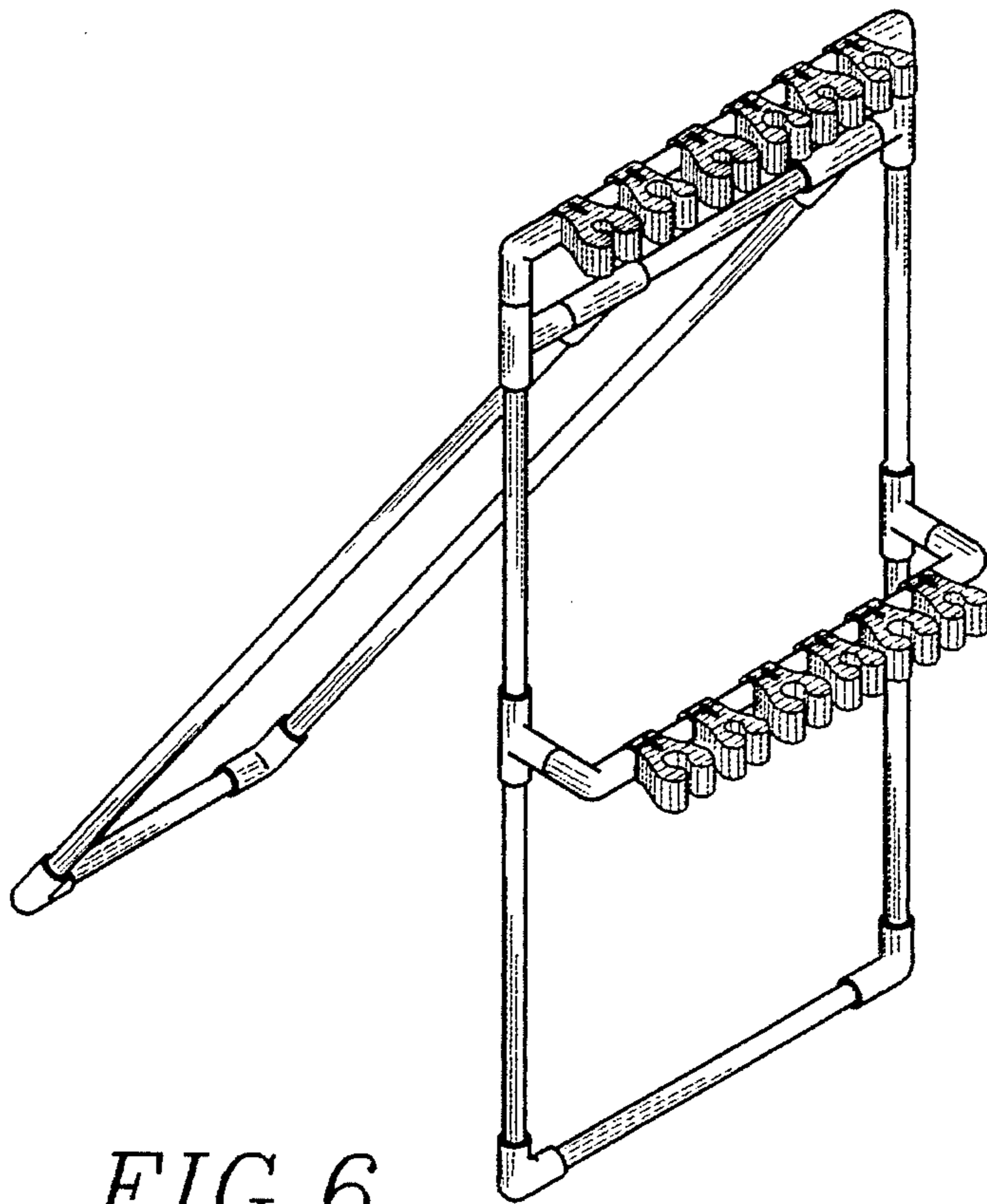


FIG. 6

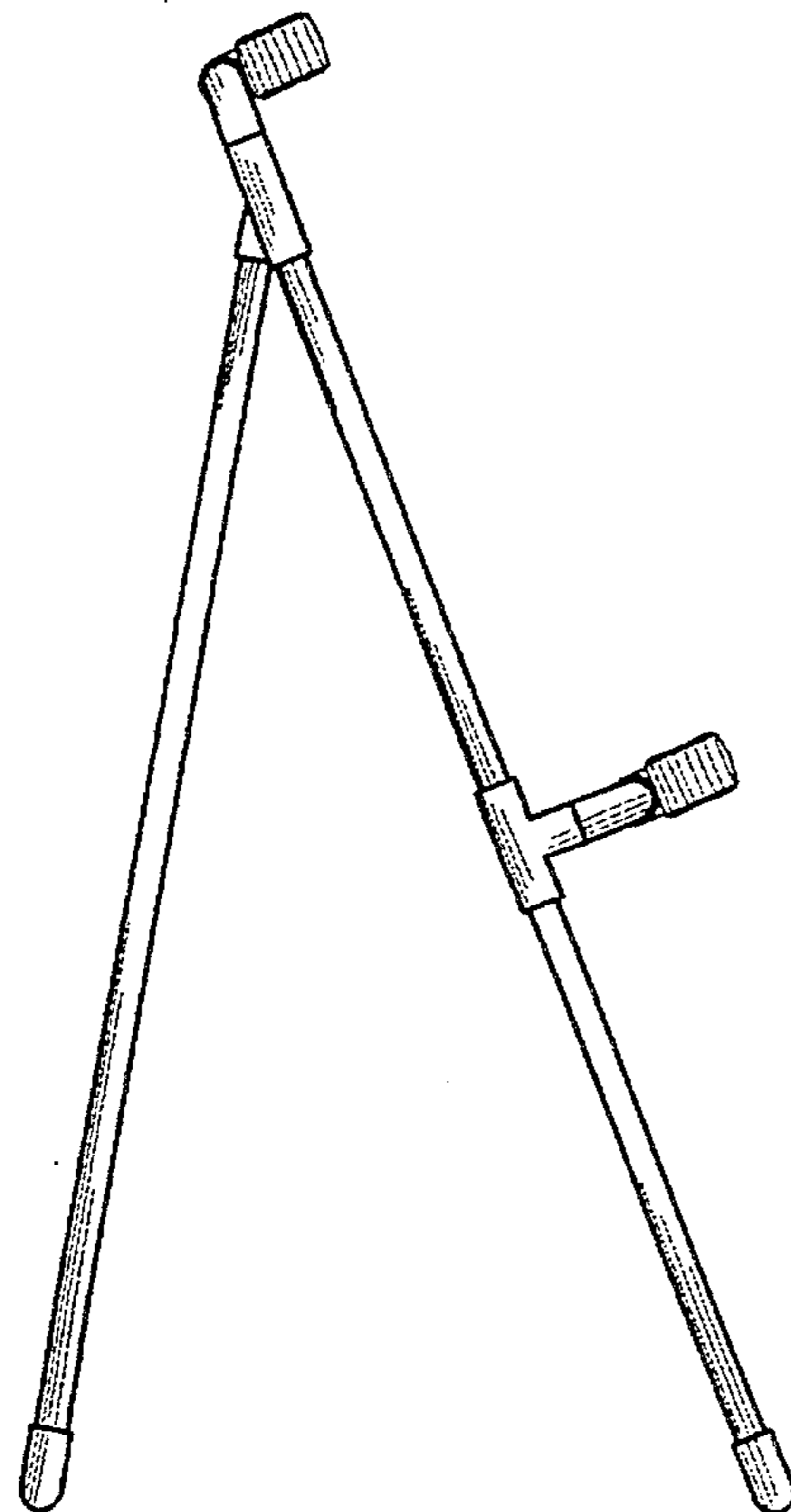


FIG. 7