



US00D372032S

**United States Patent** [19]  
**Kanemitsu**

[11] **Patent Number: Des. 372,032**

[45] **Date of Patent: \*\*\* Jul. 23, 1996**

[54] **FLANGED FITTING FOR A CATALYTIC CONVERTER**

[75] Inventor: **Toshiaki Kanemitsu**, Kobe, Japan

[73] Assignee: **Kabushiki Kaisha Kanemitsu**, Akashi, Japan

[\*] Notice: The portion of the term of this patent subsequent to Jan. 30, 2010, has been disclaimed.

[\*\*] Term: **14 Years**

[21] Appl. No.: **29,642**

[22] Filed: **Oct. 12, 1994**

[30] **Foreign Application Priority Data**

Apr. 21, 1994	[JP]	Japan	.....	6-11545
Apr. 21, 1994	[JP]	Japan	.....	6-11546
Apr. 21, 1994	[JP]	Japan	.....	6-11547

[52] **U.S. Cl.** ..... **D15/5; D23/259**

[58] **Field of Search** ..... **D12/194, 223; D23/259, 262-264, 266; 29/890, 890.08; D15/5, 199; 285/42, 44, 161, 405, 414, 416; 403/335-336; 60/299-302; 422/177, 179, 180**

[56] **References Cited**

**U.S. PATENT DOCUMENTS**

D. 252,703	8/1979	Cupit	.....	D23/259
D. 334,051	3/1993	Fell, Sr.	.....	D23/262
3,604,733	9/1971	Hubbell, III	.....	285/414 X
3,938,232	2/1976	Noda et al.	.....	29/890
4,039,292	8/1977	Morini et al.	.....	422/179

*Primary Examiner*—A. Hugo Word

*Assistant Examiner*—Lavone Tabor  
*Attorney, Agent, or Firm*—Jones, Tullar & Cooper

[57] **CLAIM**

The ornamental design for a flanged fitting for a catalytic converter, as shown and described.

**DESCRIPTION**

FIG. 1 is a front elevational view of a flanged fitting for a catalytic converter showing my new design with the rear elevational view being a mirror image;

FIG. 2 is a top plan view thereof;

FIG. 3 is a right side elevational view thereof, the left side elevational view being a mirror image;

FIG. 4 is a bottom plan view thereof;

FIG. 5 is a sectional view thereof taken along line 5—5 of FIG. 2;

FIG. 6 is a front elevational view of a second embodiment of the design shown in FIG. 1 with the rear elevational view being a mirror image;

FIG. 7 is a top plan view thereof;

FIG. 8 is a right side elevational view thereof, the left side elevational view being a mirror image;

FIG. 9 is a bottom plan view thereof;

FIG. 10 is a sectional view thereof taken along line 10—10 of FIG. 7;

FIG. 11 is a front elevational view of a third embodiment of the design shown in FIG. 1 with the rear elevational view being a mirror image;

FIG. 12 is a top plan view thereof;

FIG. 13 is a right side elevational view thereof, the left side elevational view being a mirror image;

FIG. 14 is a bottom plan view thereof; and,

FIG. 15 is a sectional view thereof taken along line 15—15 of FIG. 12.

**1 Claim, 9 Drawing Sheets**

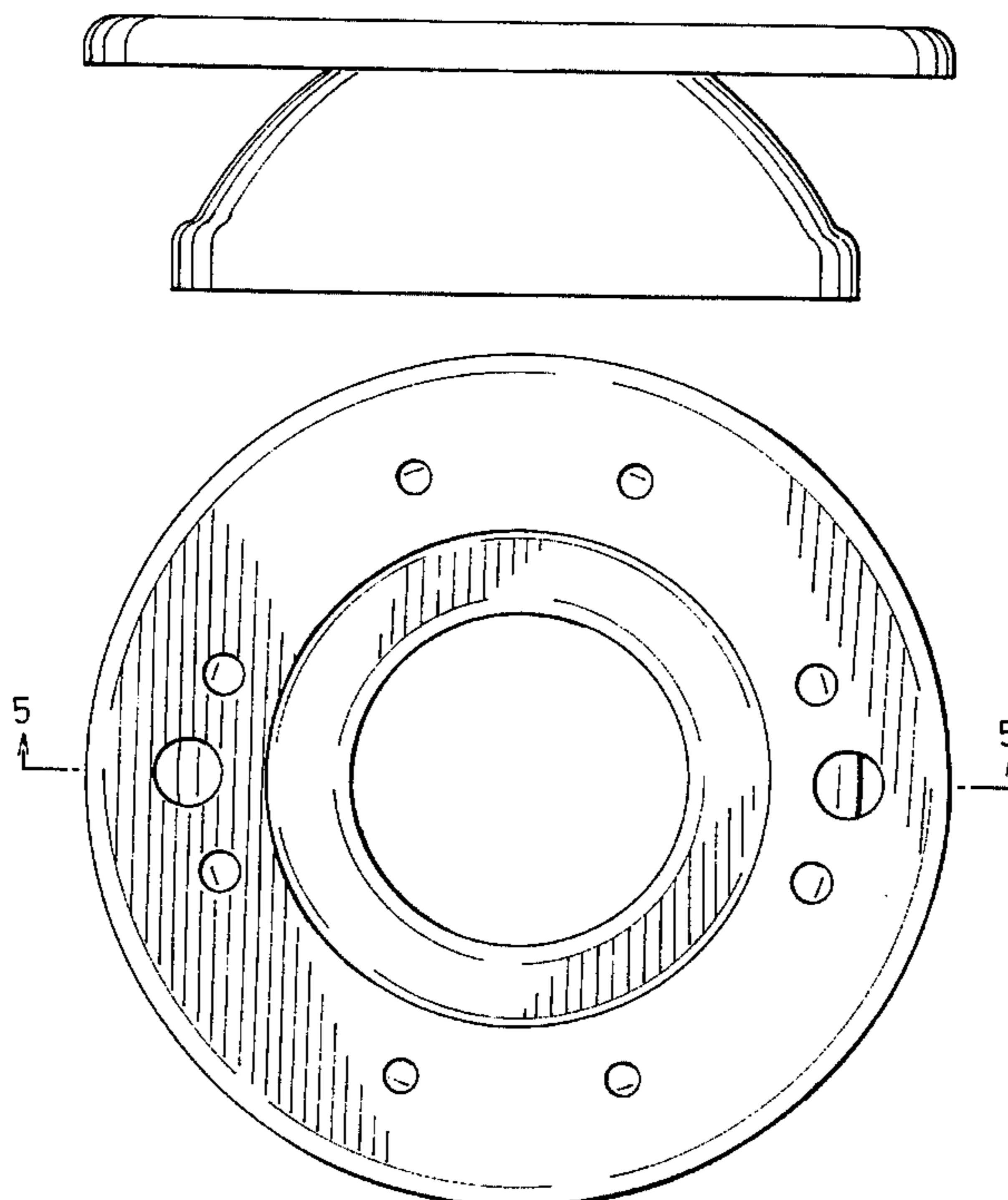

Fig.1

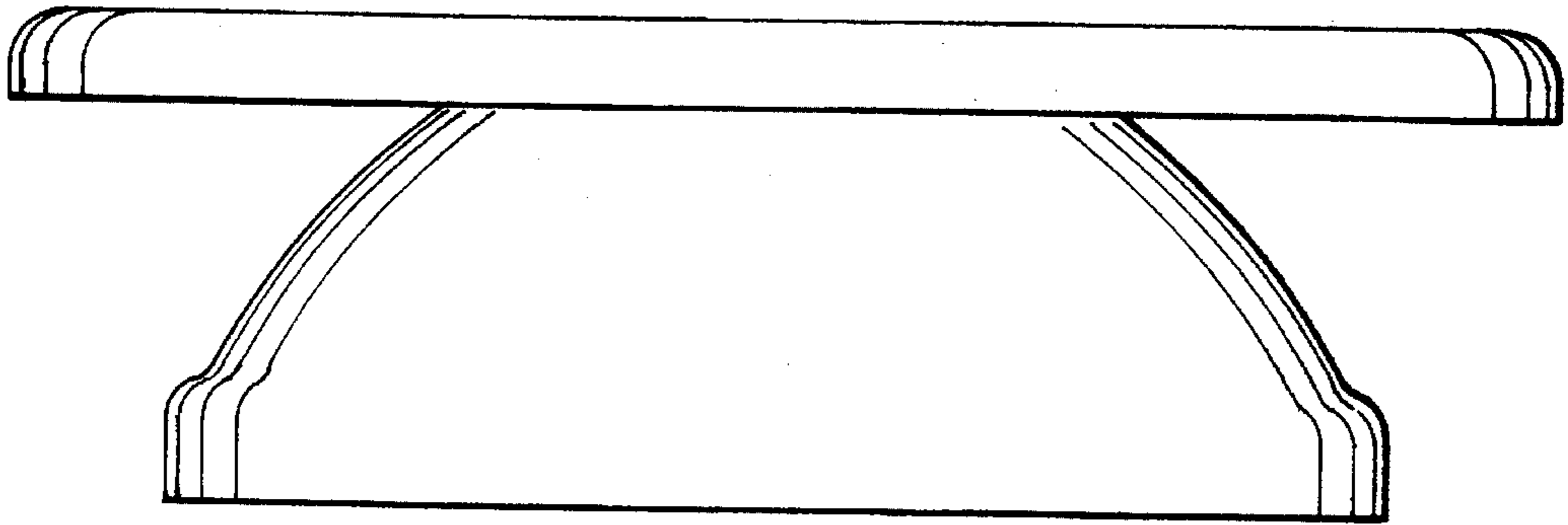

Fig.2

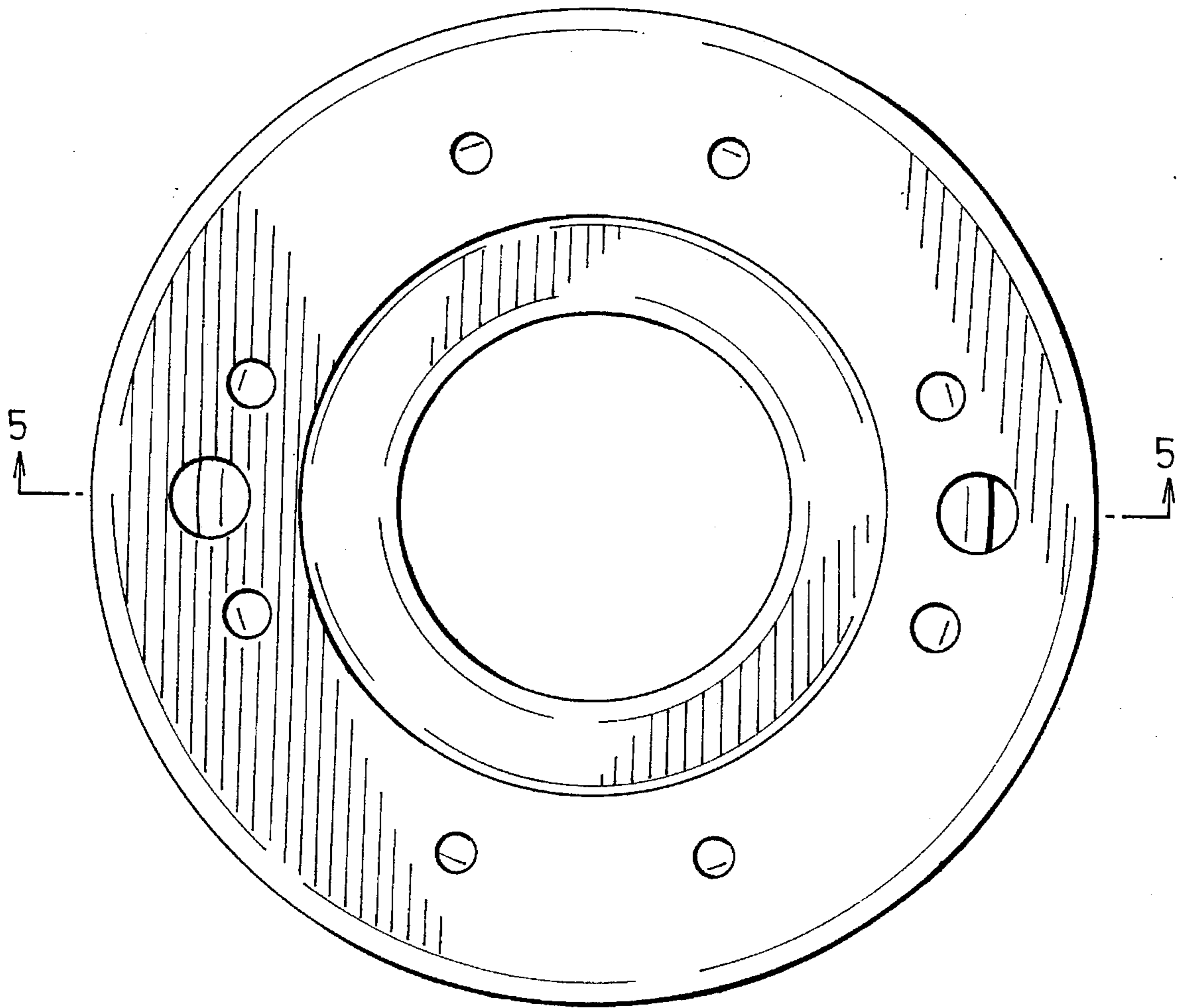

Fig.3

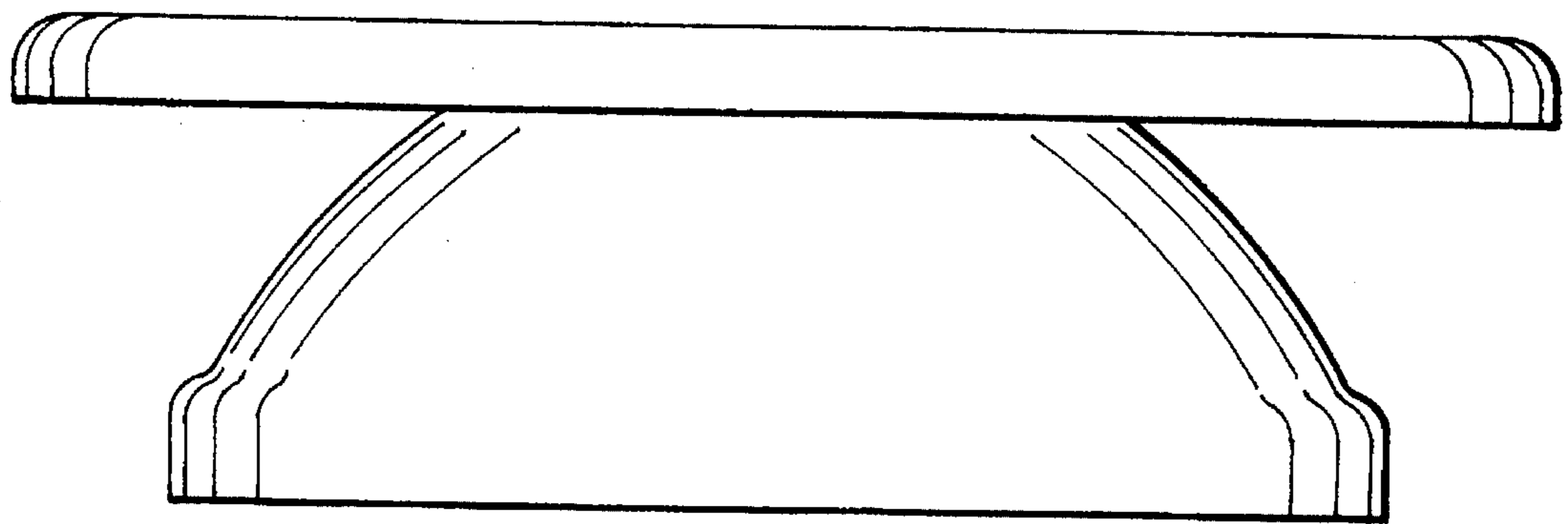

Fig.4

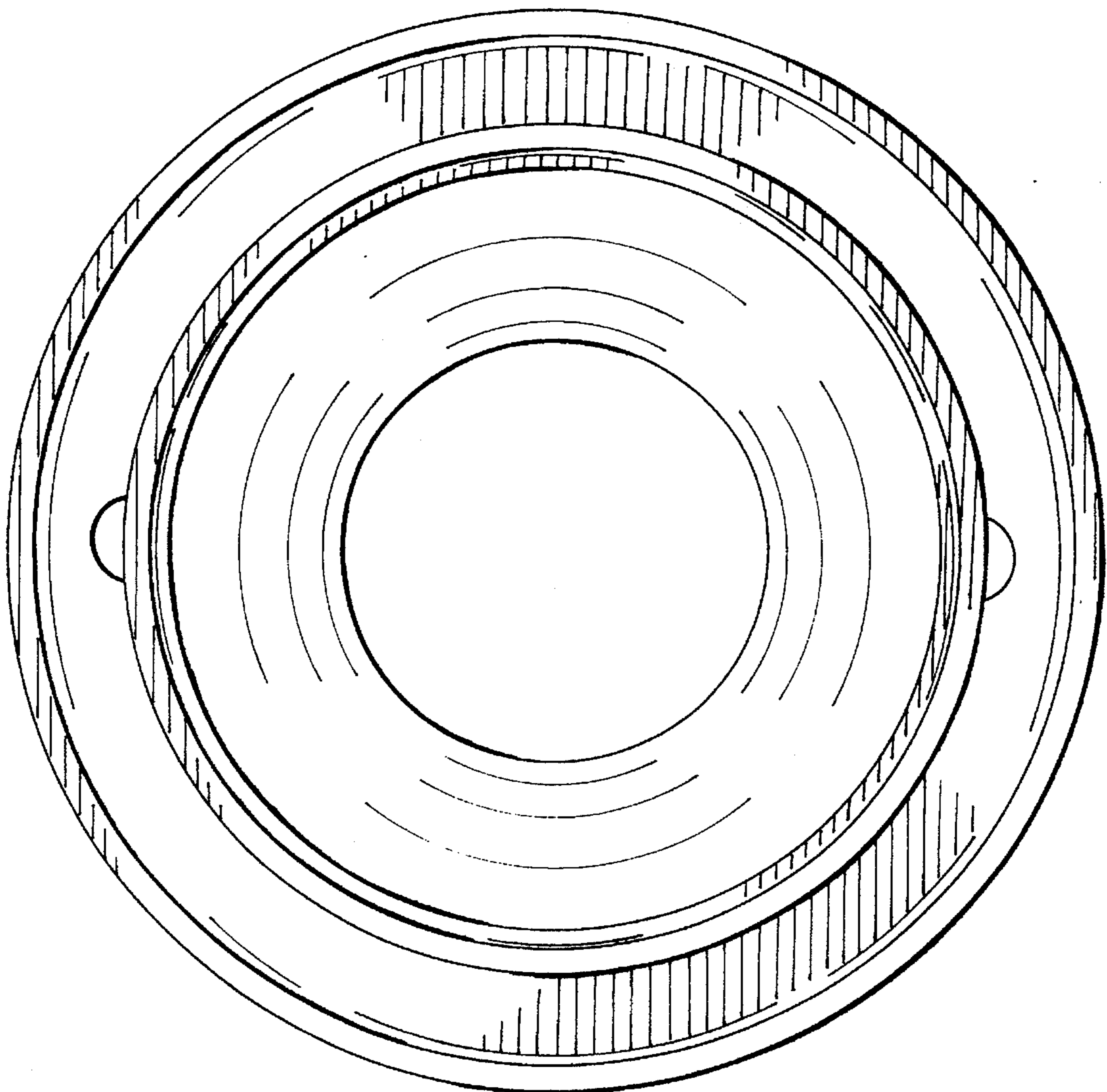

Fig.5

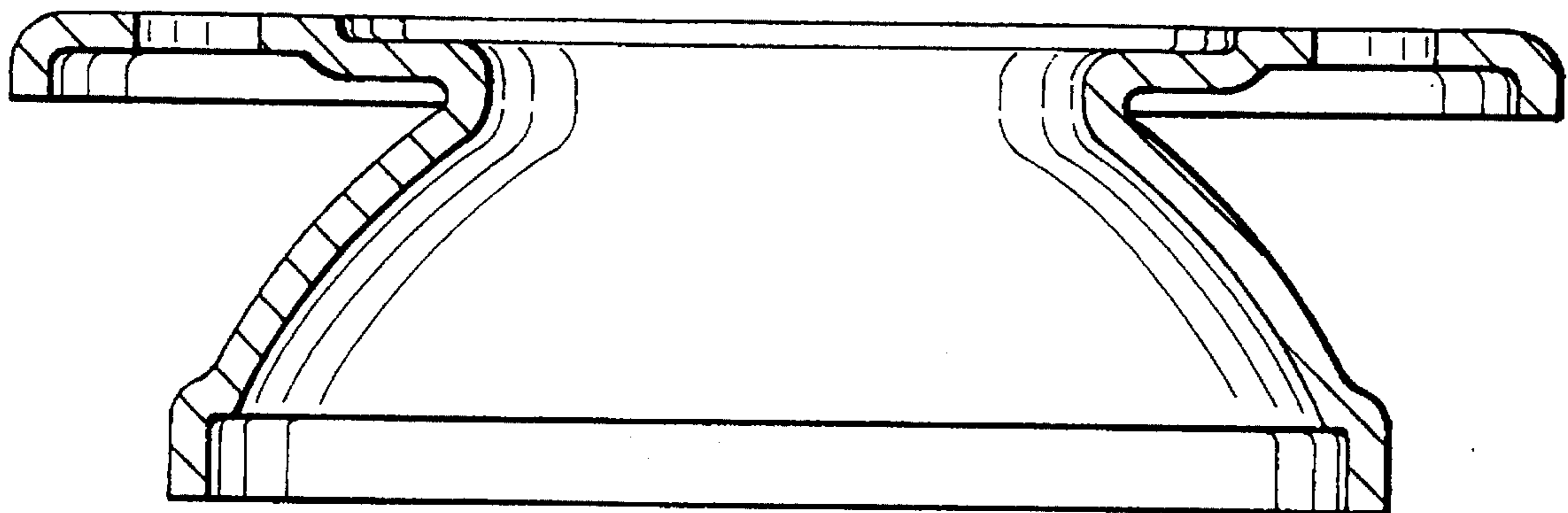

Fig.6

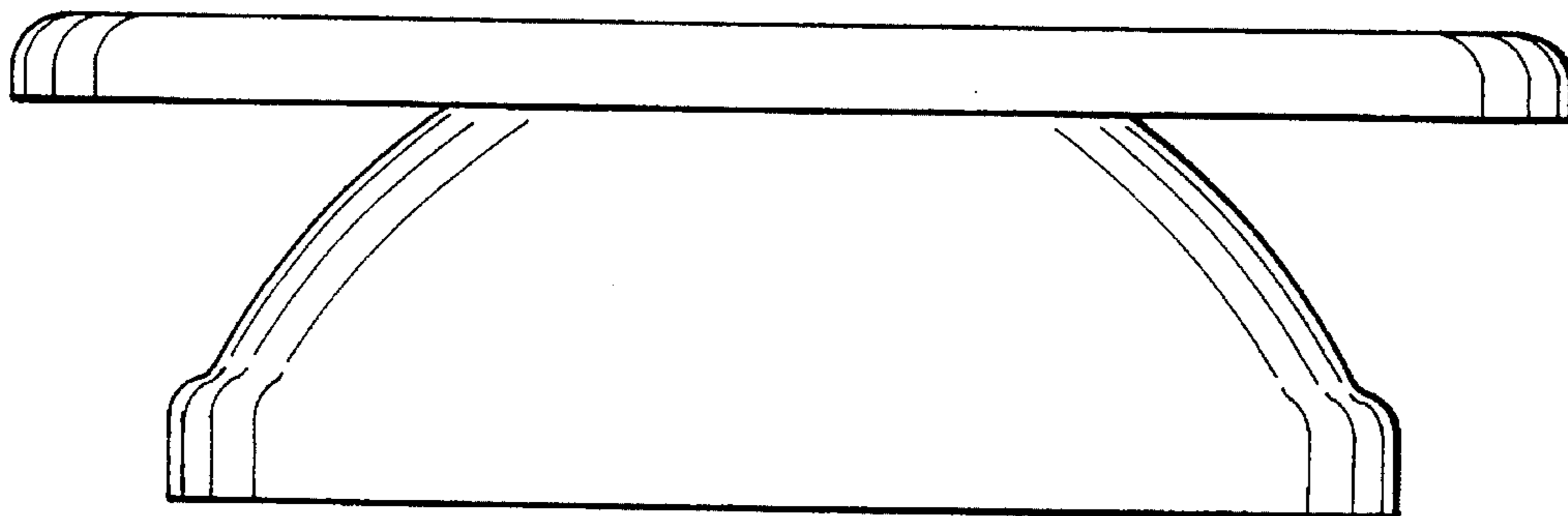

Fig.7

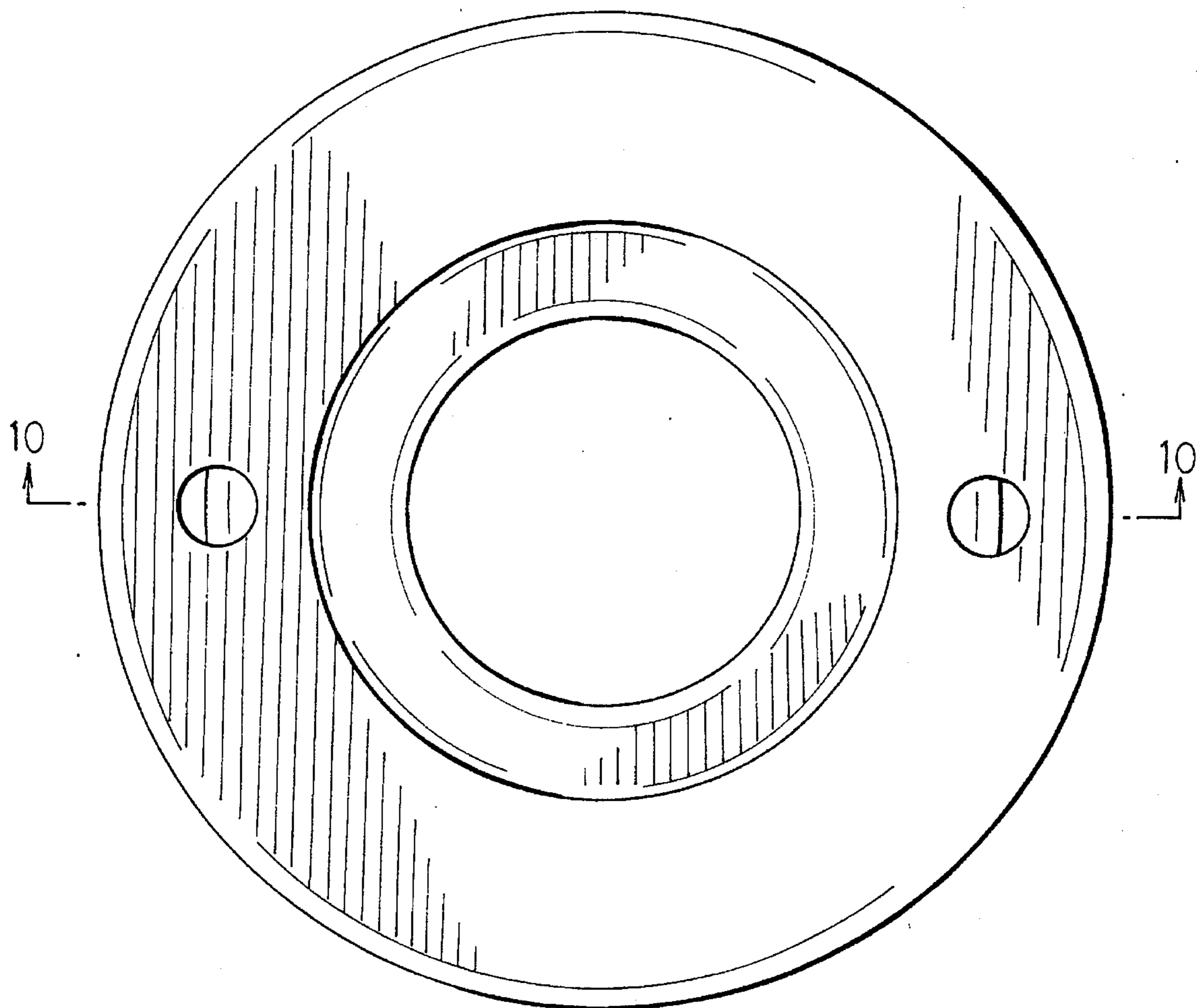

Fig.8

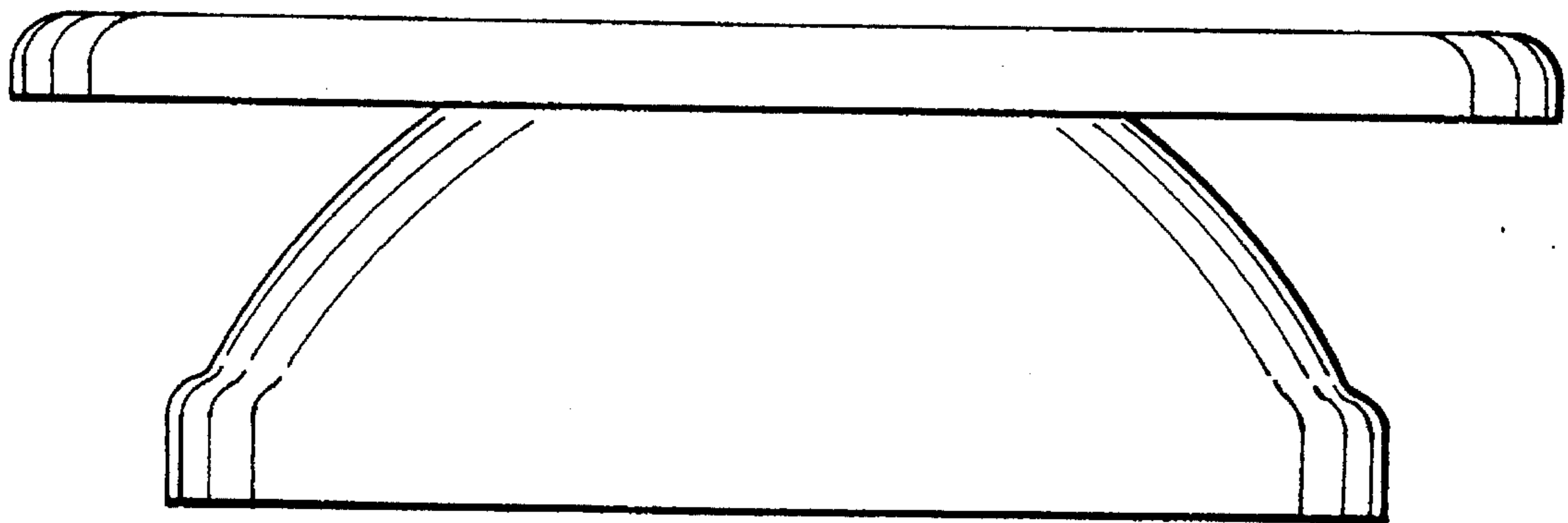

Fig.9

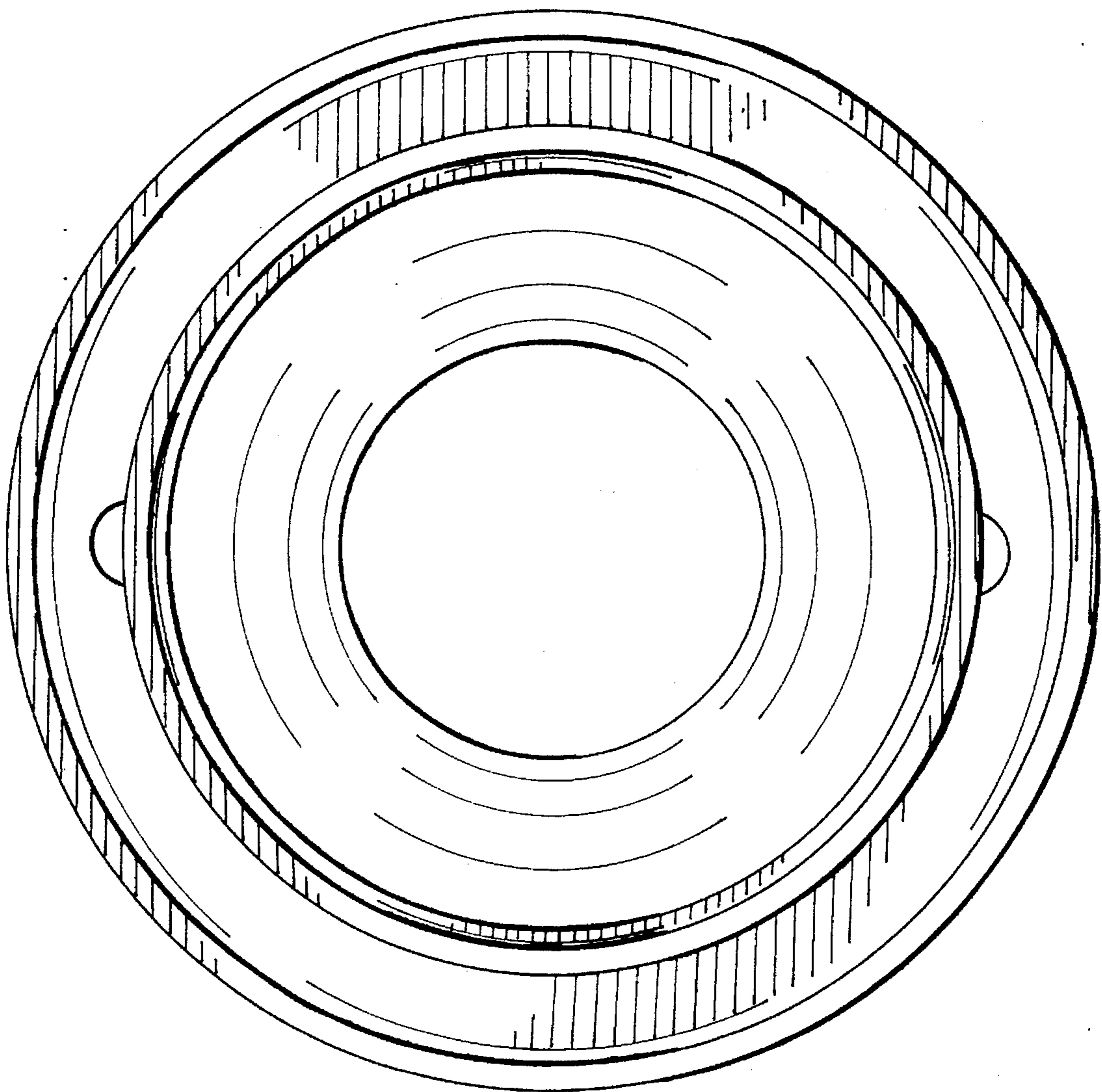

Fig.10

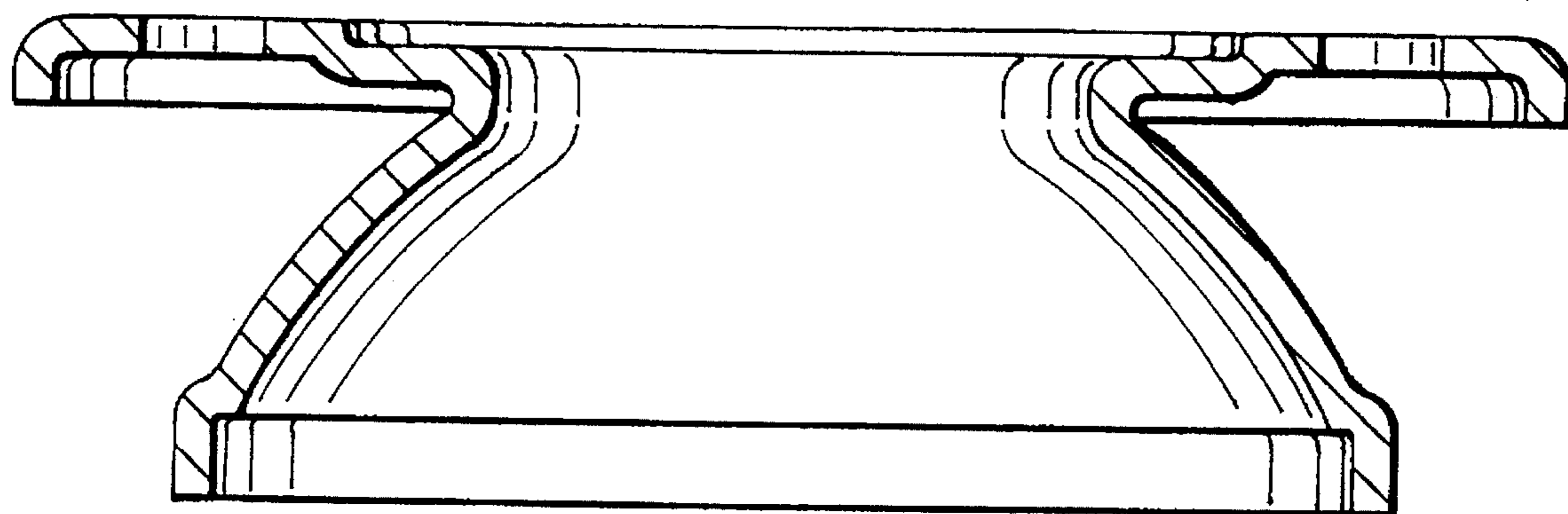

Fig.11

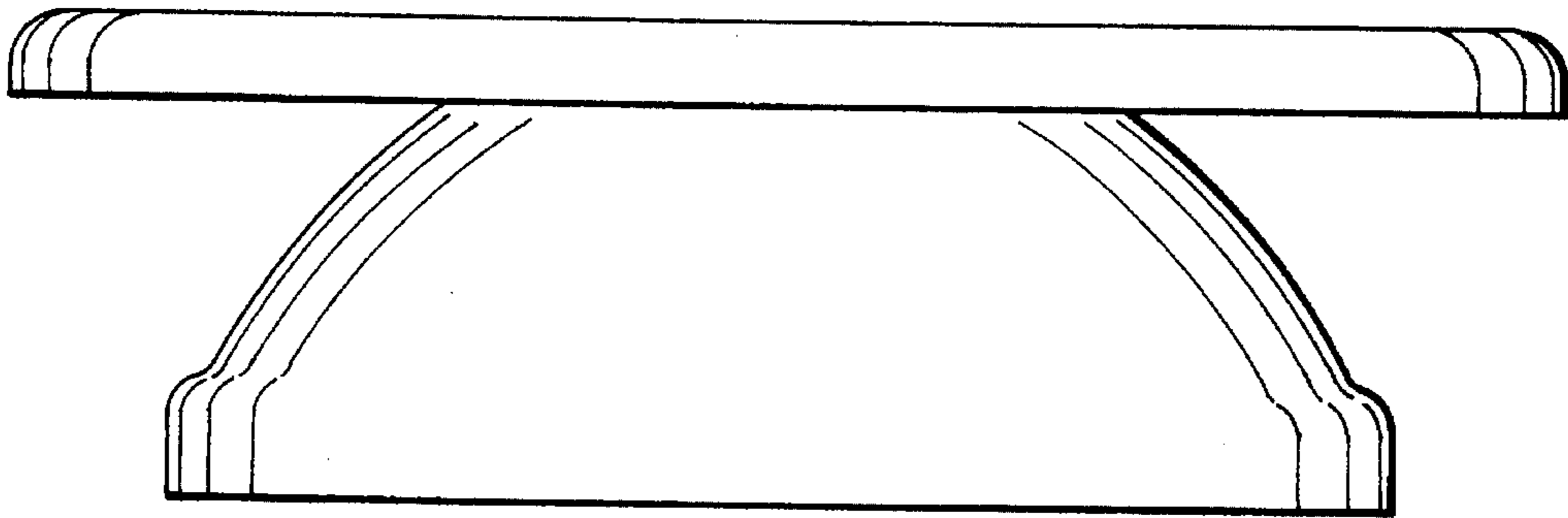

Fig.12

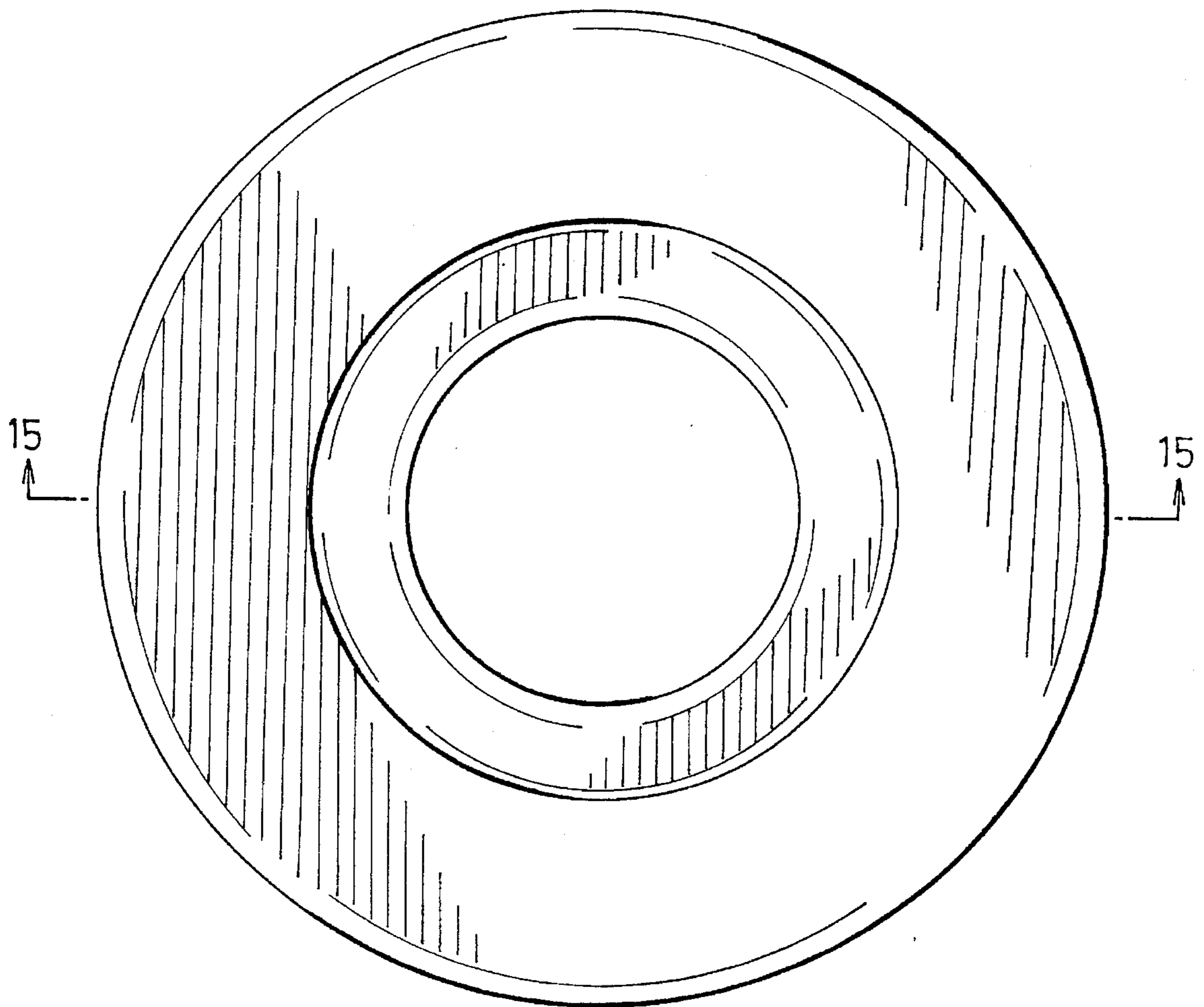



Fig.13

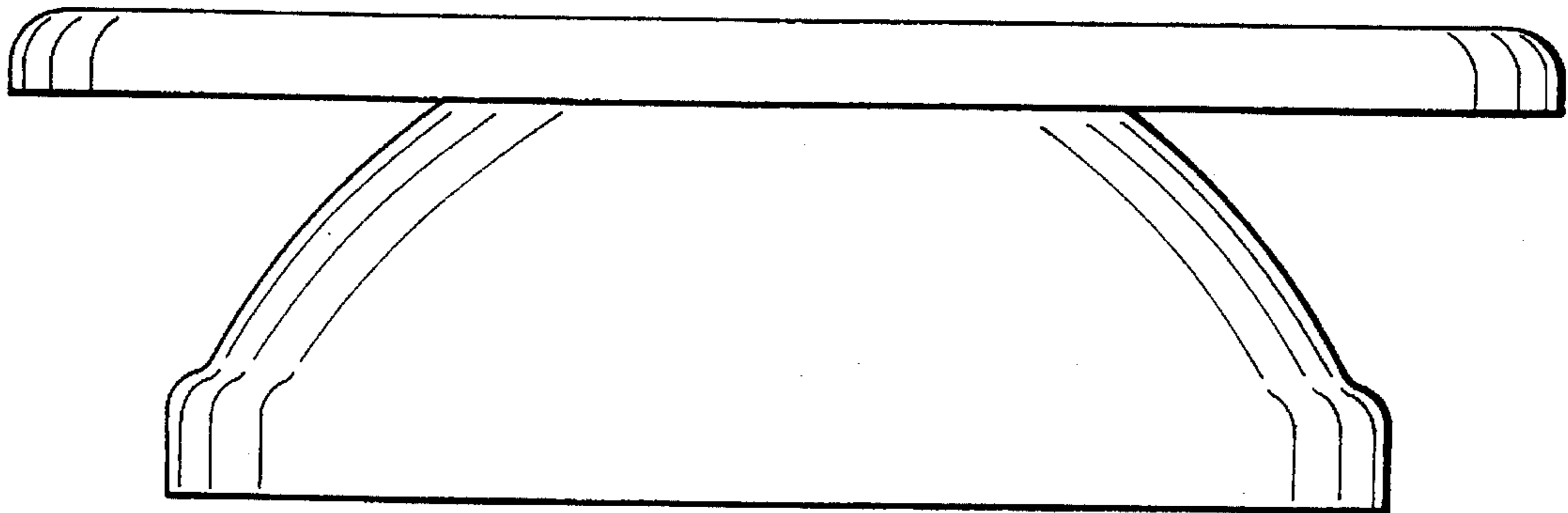

Fig.14

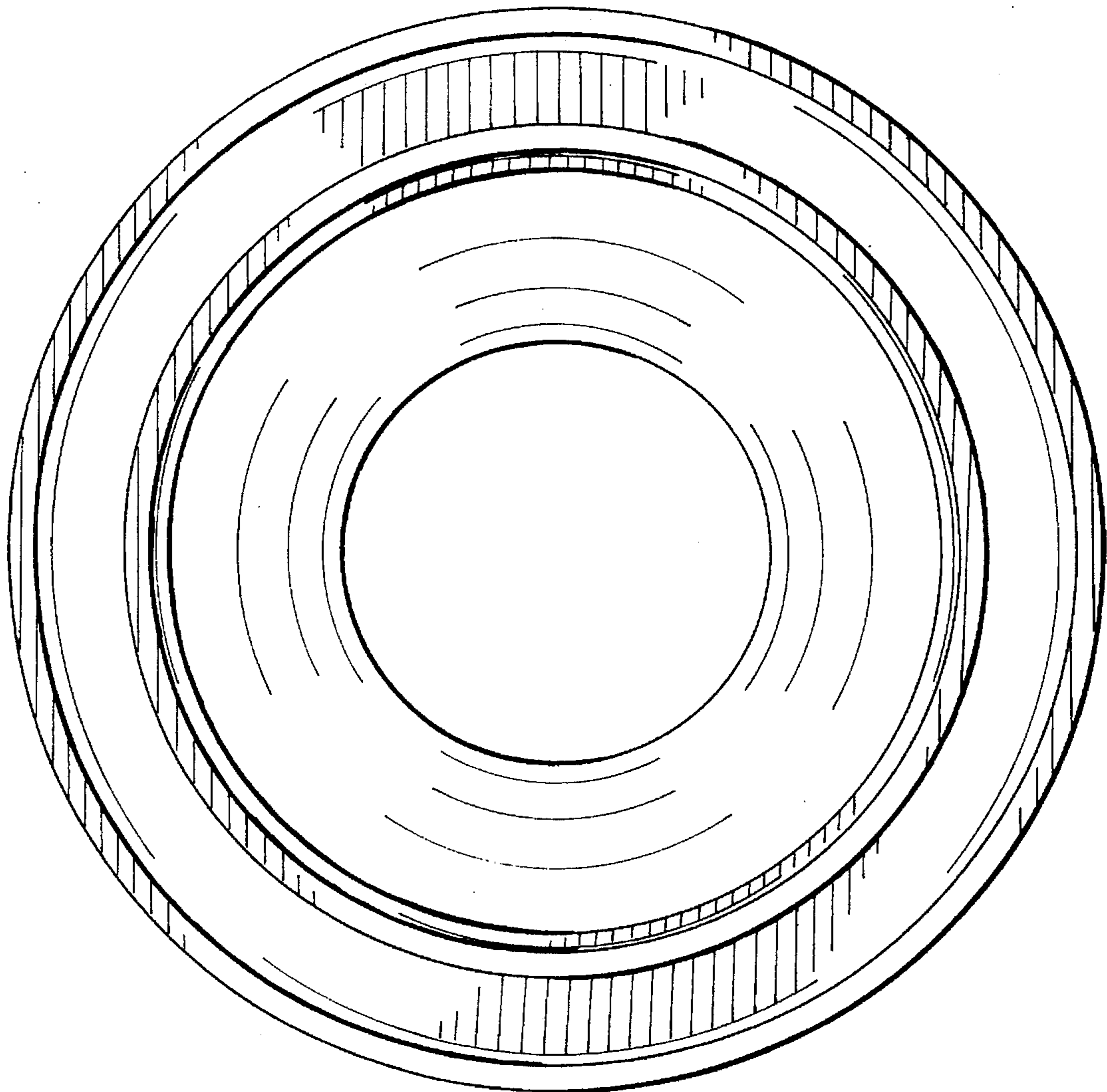

Fig.15

