



US00D372002S

# United States Patent [19]

[11] Patent Number: **Des. 372,002**

**Busby et al.**

[45] Date of Patent: **\*\*Jul. 23, 1996**

[54] **BICYCLE FRAME**

5,253,890	10/1993	Takamiya et al.	280/281.1
5,259,637	11/1993	Busby	280/284
5,271,784	12/1993	Chen et al.	280/288.3

[75] Inventors: **James S. Busby**, Costa Mesa; **Steven H. Olson**, Corona; **Stanley A. Needle**, Irvine; **Sean W. Flickinger**, Costa Mesa; **Jeffrey A. Soucek**, Huntington Beach, all of Calif.

### FOREIGN PATENT DOCUMENTS

3033294	4/1981	Germany	280/285
428442	12/1947	Italy	280/285
15332	9/1916	United Kingdom	.
220760	8/1924	United Kingdom	.

[73] Assignee: **GT Bicycle, Inc.**, Santa Ana, Calif.

[\*\*] Term: **14 Years**

### OTHER PUBLICATIONS

[21] Appl. No.: **43,245**

1992 Cannondale Spec—Suspension Mountain Bicycles—Article—10 pgs.

[22] Filed: **Aug. 23, 1995**

TREK 9000 Series Spec—"This Beauty Is A Beast"—Article—8 pgs., 1992.

[52] U.S. Cl. .... **D12/111**

[58] Field of Search ..... D12/111; 280/281.1, 280/288.1, 288.2, 288.3

FISHER RS-1—Article—4 pgs.—Mountain Bike Action/Mar. '92.

SUSPENSION MANIA STRIKES CYCLING—Mountain Bike Action/Feb. '92 3 pgs.

BOULDER INTREPID AL—2 pgs.—Mountain Bike Action/Mar. '92.

[56] **References Cited**

#### U.S. PATENT DOCUMENTS

D. 357,651	4/1995	Isaac et al.	D12/111
439,095	10/1890	Becker	280/284
578,615	3/1897	Travis	280/284
606,323	6/1898	Wronski	280/284
657,667	9/1900	Mills	280/284
944,795	12/1909	Leet et al.	280/284
1,047,430	12/1912	Michaelson	280/284
1,257,761	2/1918	Strand	280/284
1,298,958	4/1919	Johnston	280/284
1,412,012	4/1922	Bruno	280/284
1,594,079	7/1926	Tanner	280/284
3,917,313	11/1975	Smith et al.	280/284
4,322,088	3/1982	Miyakoshi et al.	280/284
4,506,755	3/1985	Tsuchida et al.	180/227
4,529,056	7/1985	Kreuz	180/227
4,673,053	6/1987	Tanaka et al.	180/227
4,789,174	12/1988	Lawwill	280/284
4,902,458	2/1990	Trimble	280/288.3
4,951,791	8/1990	Belil Creixell	180/219
4,997,197	3/1991	Shultz	280/275
5,080,385	1/1992	Suplesses	280/288.3
5,098,114	3/1992	Jones	280/284
5,116,071	5/1993	Calfee	280/281.1
5,121,937	6/1992	Lawwill	280/284
5,205,572	4/1993	Buell et al.	280/284
5,244,224	9/1993	Busby	280/284
5,249,818	10/1993	Patterson	280/281.1

(List continued on next page.)

*Primary Examiner*—Melody N. Brown  
*Attorney, Agent, or Firm*—Stetina Brunda & Buyan

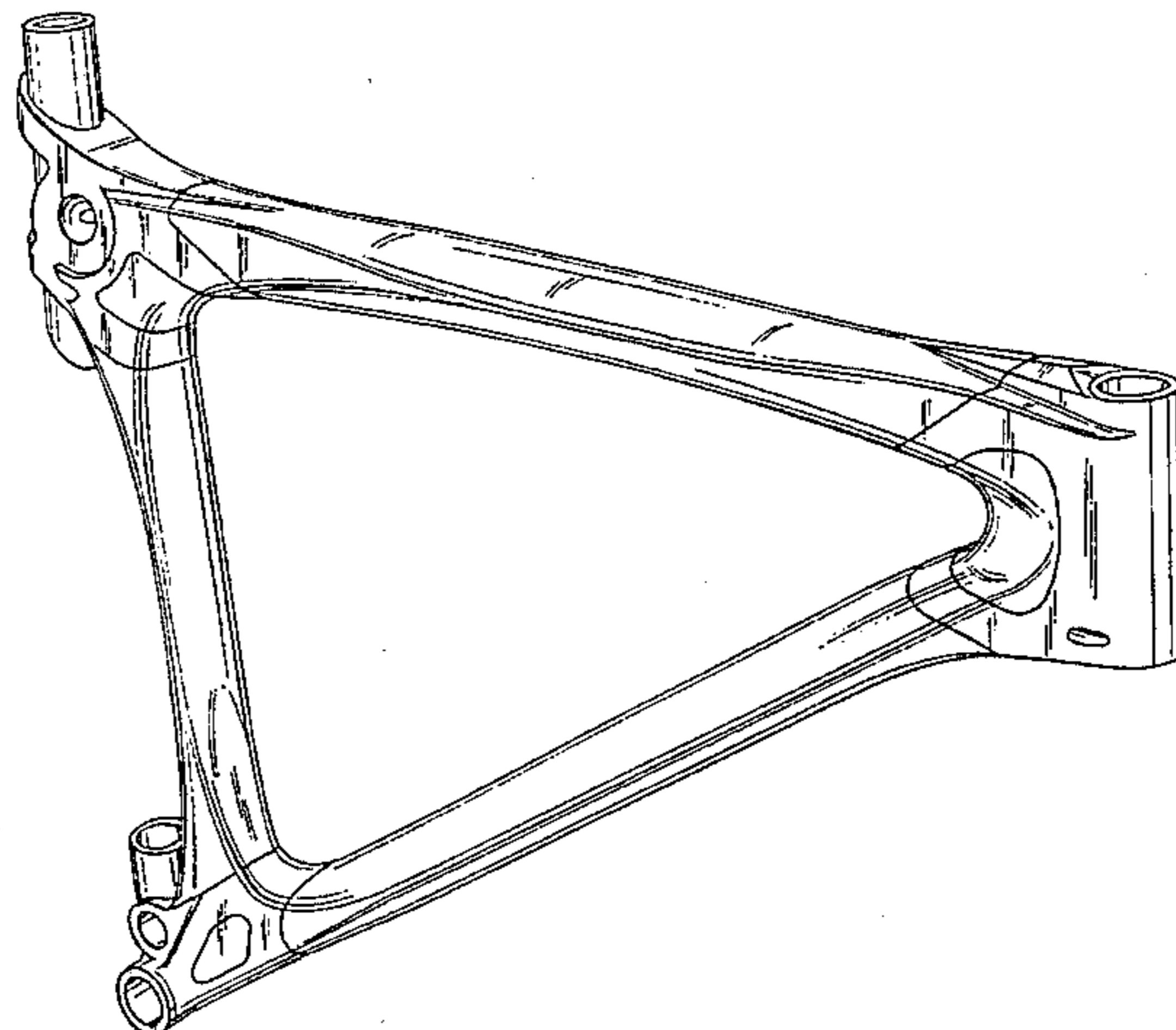
[57] **CLAIM**

The ornamental design for a bicycle frame, as shown and described.

### DESCRIPTION

FIG. 1 is a front perspective view of the bicycle frame of the present invention, showing our new design;  
FIG. 2 is a rear perspective view thereof;  
FIG. 3 is a right side elevational view thereof;  
FIG. 4 is a left side elevational view thereof;  
FIG. 5 is a cross-sectional view taken along line 5—5 of FIG. 3;  
FIG. 6 is a rear elevational view thereof;  
FIG. 7 is a front elevational view thereof;  
FIG. 8 is a top plan view thereof; and,  
FIG. 9 is a bottom plan view thereof.

**1 Claim, 3 Drawing Sheets**



OTHER PUBLICATIONS

TEAM SHOCKBLOK—6 pgs.—Mountain Bike Action/  
Jul. '92.

MOUNTAIN BIKE ACTION, Oct. 1992, pp. 10, 25–26,  
28–29, 31, 36–37, 39–41, 44–45, 47, 58, 70, 73, 76, 79, 123,  
and 130.

BICYCLING, Nov. 1992, pp. 26–27, 58, 63–64, and 105.

MOUNTAIN BIKING, Nov. 1992, vol. 6, No. 11, pp. 6–9,  
25, 48–49, 65, 71, 73, 108–109, 115, 124, 129, 140, 143, 163  
and 169.

MOUNTAIN BIKING, Dec. '92, pp. 1–2, 5, 18, 44–49, 77,  
127, and 160.

MOUNTAIN BIKING, Jan. '93, vol. 7, No. 1, pp. 32–33,  
40, 45, 71, 75, 82–83, 115 and 117.

WELCOME TO THE NEXT GENERATION . . . —9  
pgs.—Mountain Bike—Jun. '92.

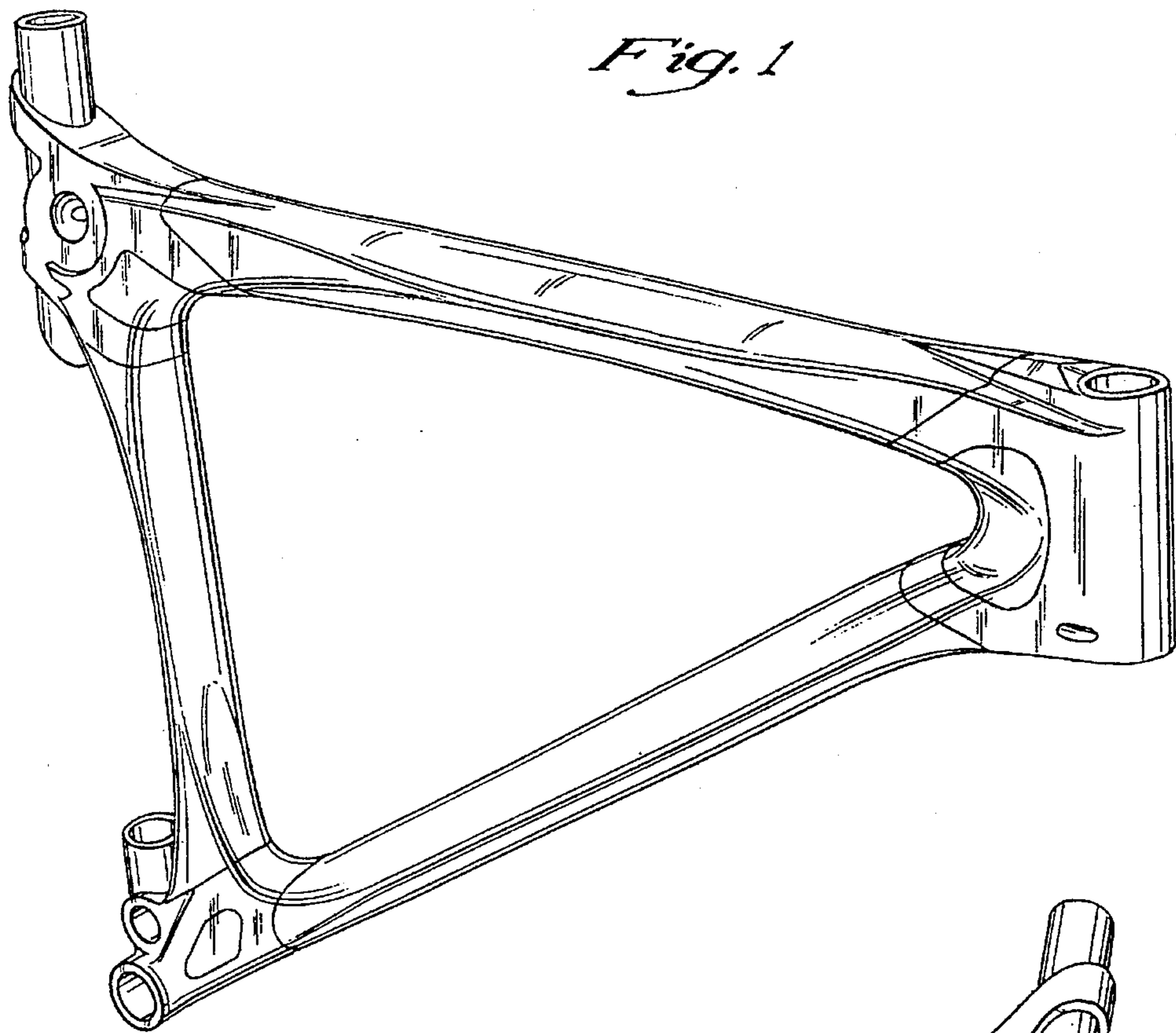
SCHWINN S.A.S.S.—7 pgs.—Mountain Bike Action—  
May '92.

OFFROAD PRO-FLEX 550—3 pgs.—OFFROAD.

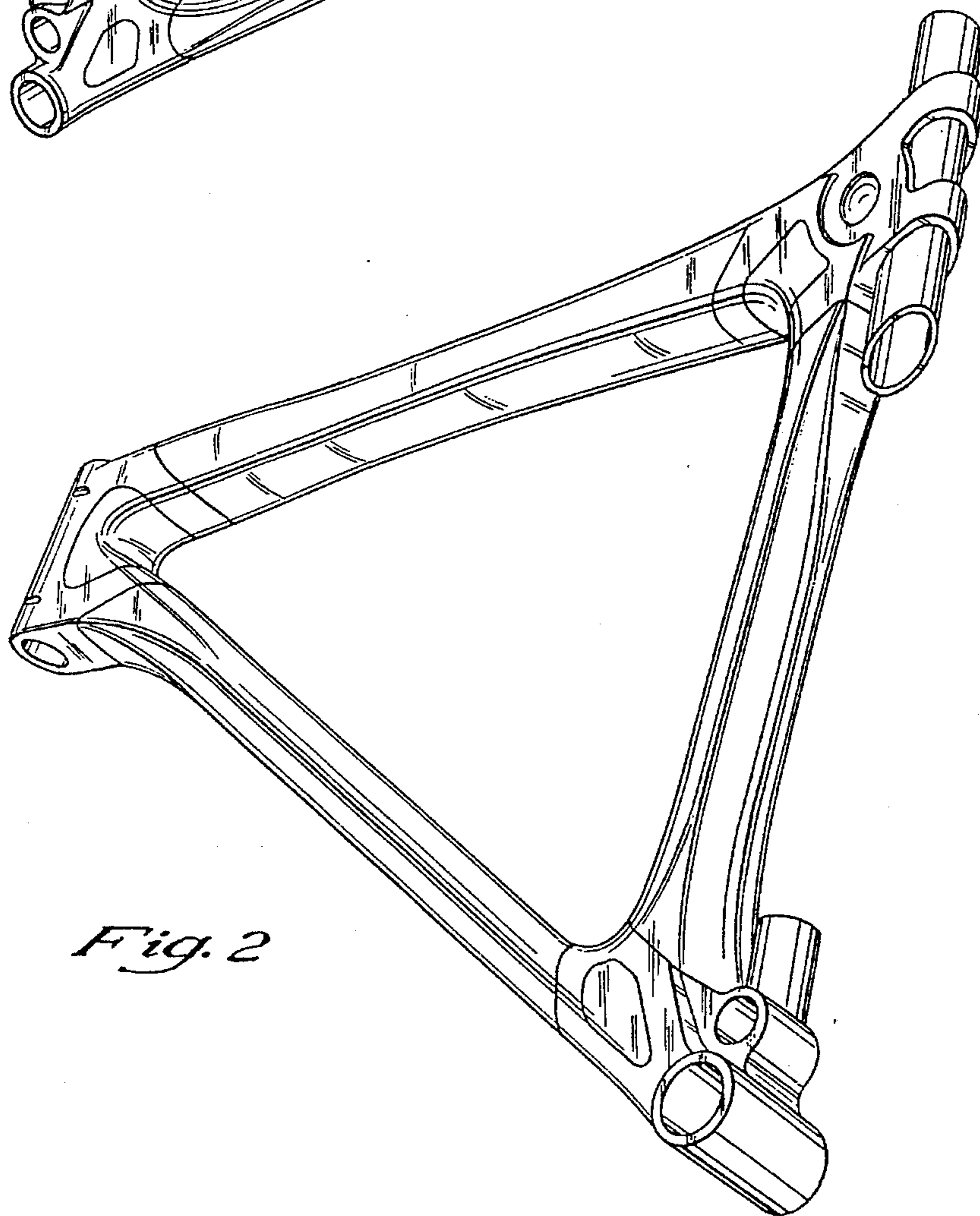
IF THE BEST MOTORCYCLE . . . “LITESPEED SUS-  
PENSION”, Mountain Bike—Jul. '92 8 pgs.

SLINGSHOT—*Mountain & City Biking*, 6 pgs.

GUIDE TO SUSPENSION AND HIGH PERFORMANCE,  
vol. 3—1992, pp. 9, 13–15, 17, 30–31, 36–37, 42–45, 47,  
53, 60, 69, 71, 76, 85–87, 92, 96, 98, 100, 108–112, 117 and  
119.

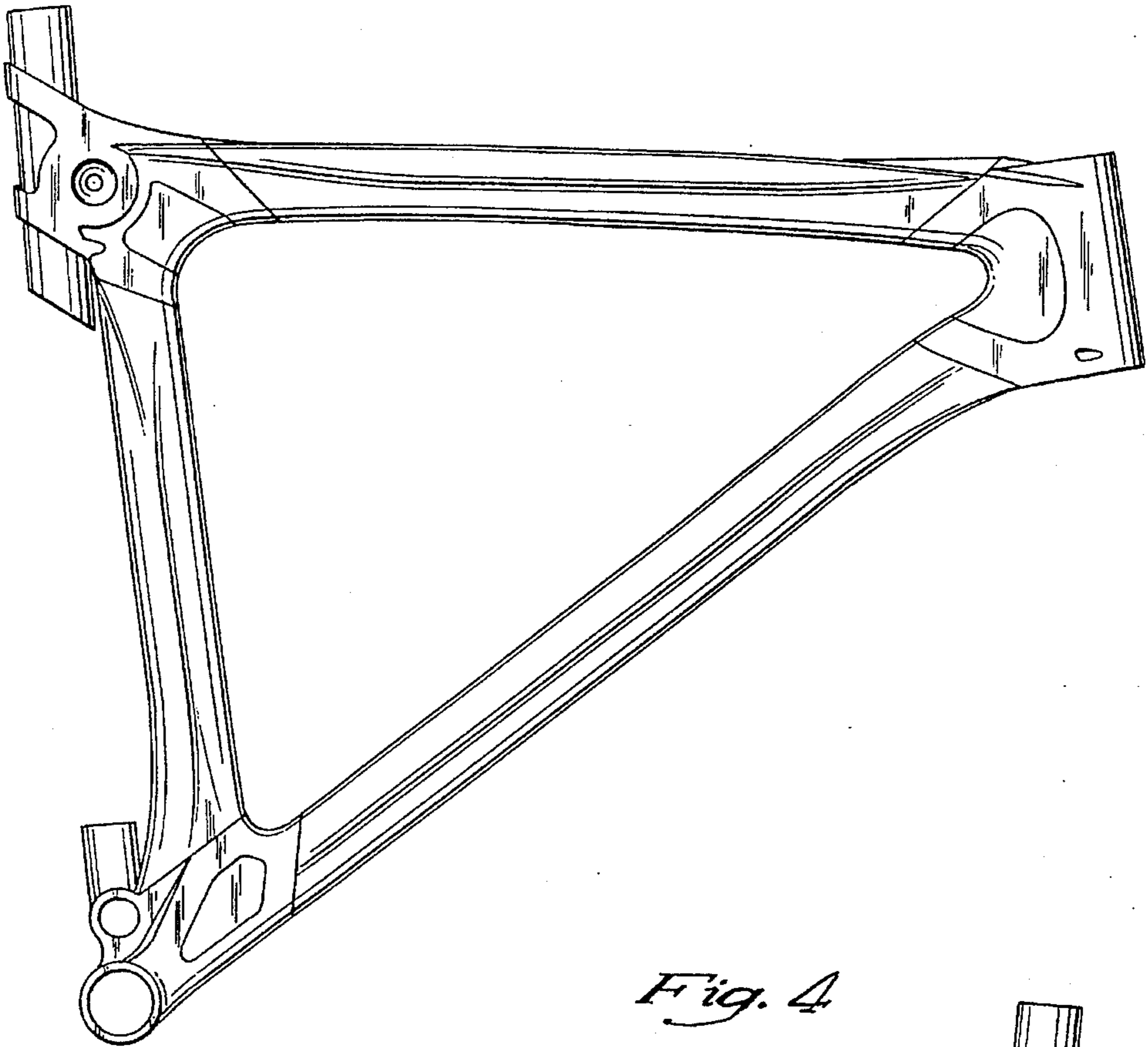


*Fig. 1*

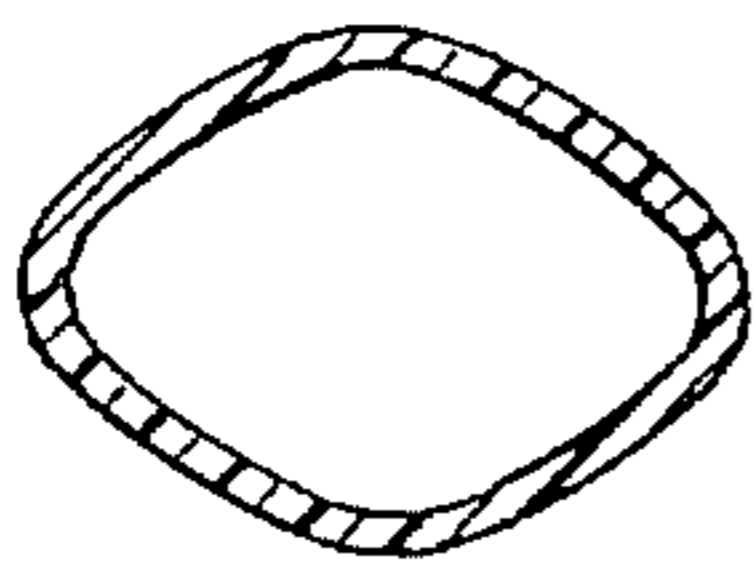
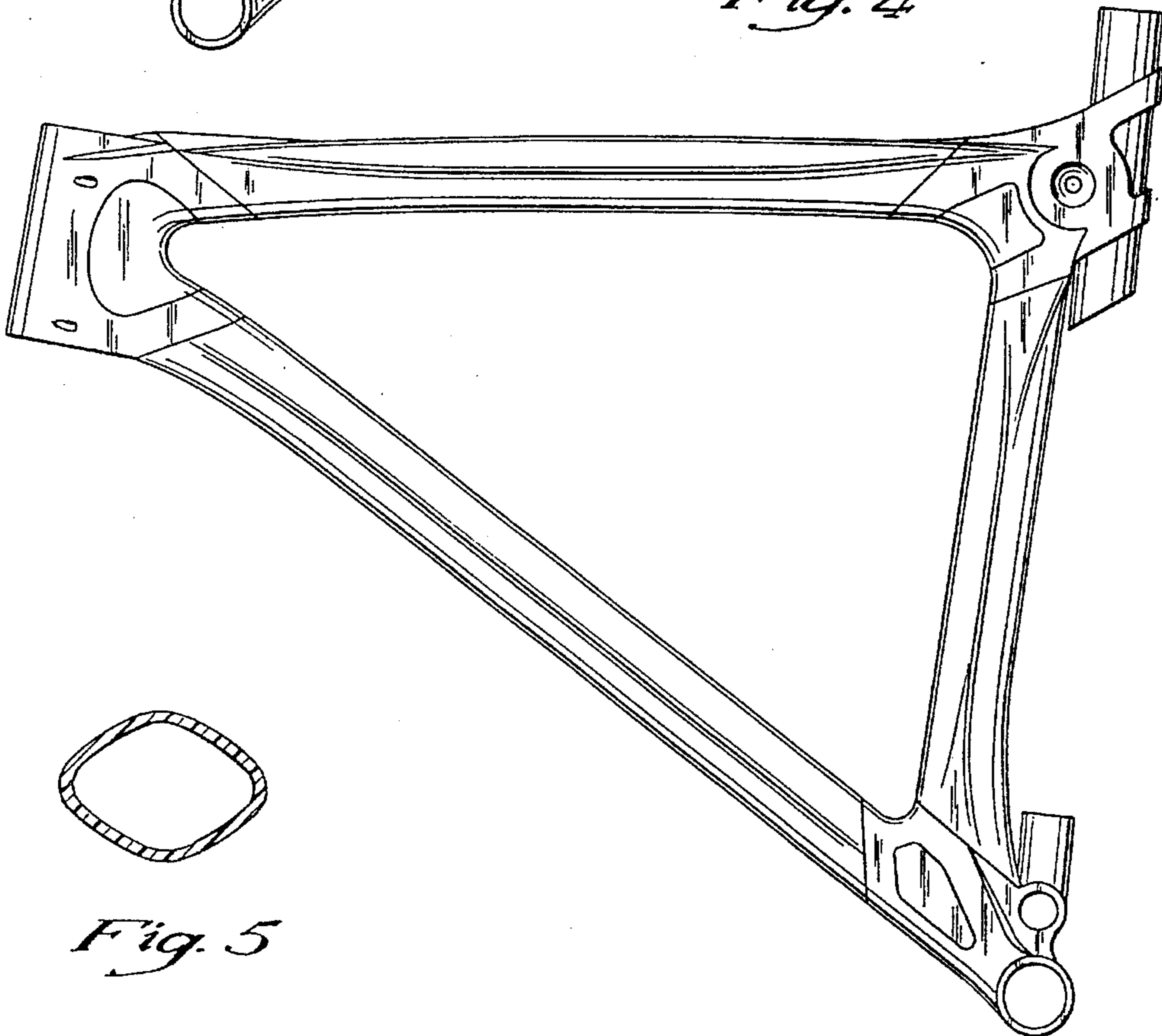


*Fig. 2*

*Fig. 3*

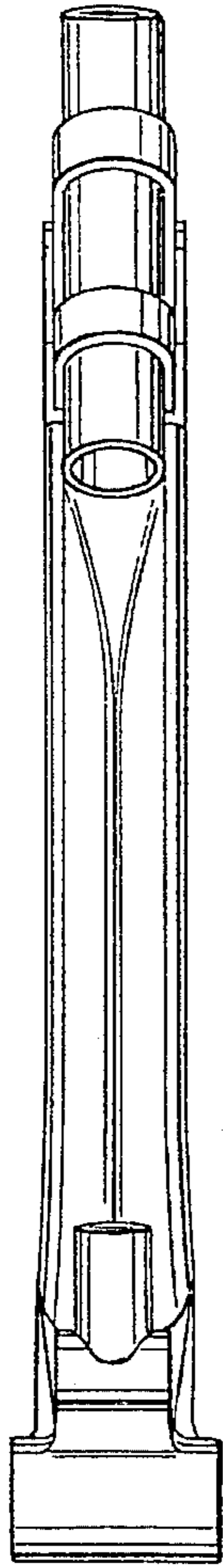


*Fig. 4*

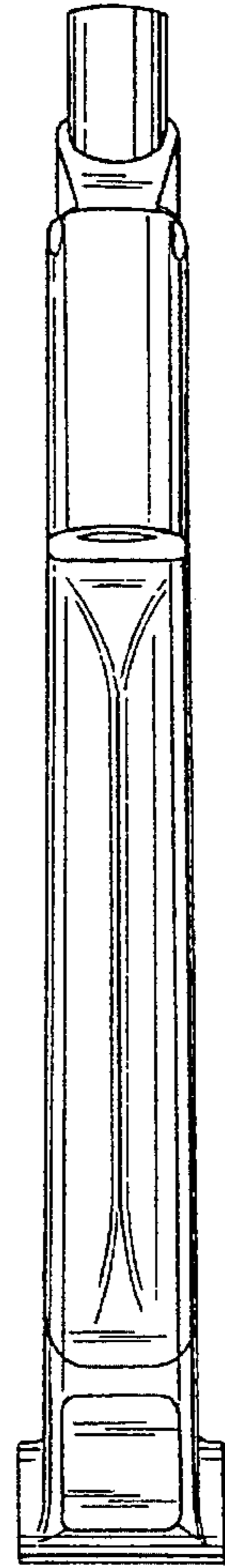


*Fig. 5*

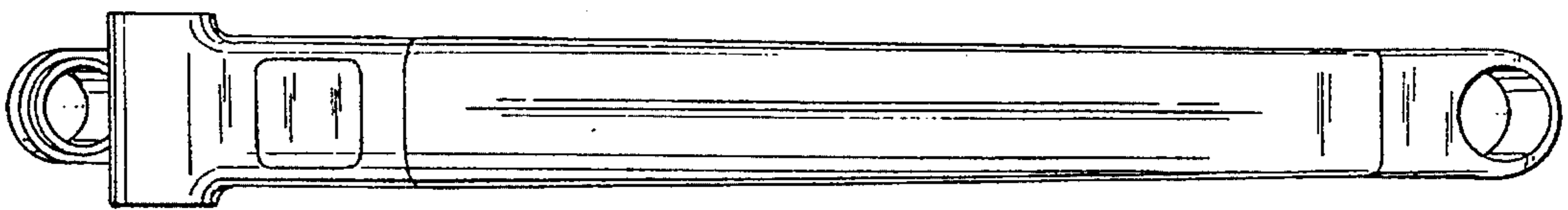
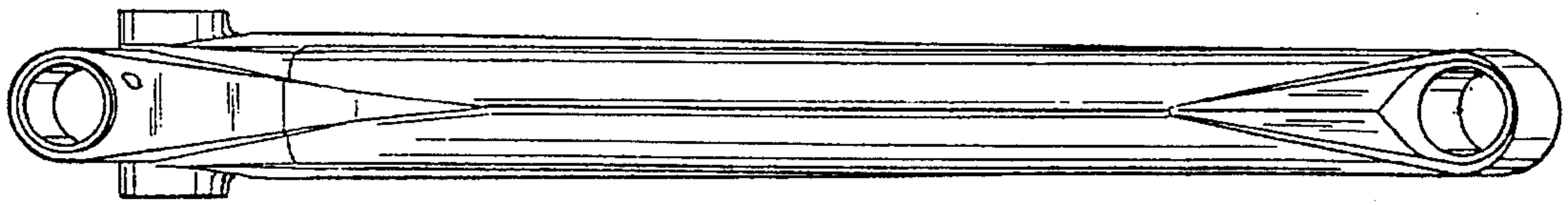
*Fig. 6*



*Fig. 7*



*Fig. 8*



*Fig. 9*