



US00D371528S

United States Patent [19] Speck

[11] Patent Number: **Des. 371,528**

[45] Date of Patent: ****Jul. 9, 1996**

[54] **TWO WHEELED VEHICLE** 4,819,980 4/1989 Sakata et al. 296/35.1

[76] Inventor: **Thompson W. Speck**, 104 Spruce Dr.,
Marshall, Minn. 56258

[**] Term: **14 Years**

[21] Appl. No.: **22,893**

[22] Filed: **May 16, 1994**

[52] U.S. Cl. **D12/107**

[58] Field of Search D12/85, 107, 110,
D12/402; 180/210, 211, 215; 296/15, 185

[56] References Cited

U.S. PATENT DOCUMENTS

D. 262,957	2/1982	Harmer	D12/402
D. 269,505	6/1983	Gordon	D12/85
D. 273,186	3/1984	Bruning	D12/85
D. 320,958	10/1991	Kimura et al.	D12/85
D. 329,111	9/1992	Malewicki	D12/85
D. 333,450	2/1993	Hyde, Sr.	D12/107
4,200,168	4/1980	Moog	180/282

FOREIGN PATENT DOCUMENTS

1004084	1/1977	Canada	104/118
0077576	4/1986	Japan	280/758

Primary Examiner—Melody N. Brown

[57] CLAIM

The ornamental design for a two wheeled vehicle, as shown and described.

DESCRIPTION

FIG. 1 is a perspective view of the two wheeled vehicle showing my new design;
FIG. 2 is a top plan view thereof;
FIG. 3 is a front elevational view thereof;
FIG. 4 is a side elevational view thereof, the opposite side being a mirror image thereof; and,
FIG. 5 is a rear elevational view thereof.

1 Claim, 4 Drawing Sheets

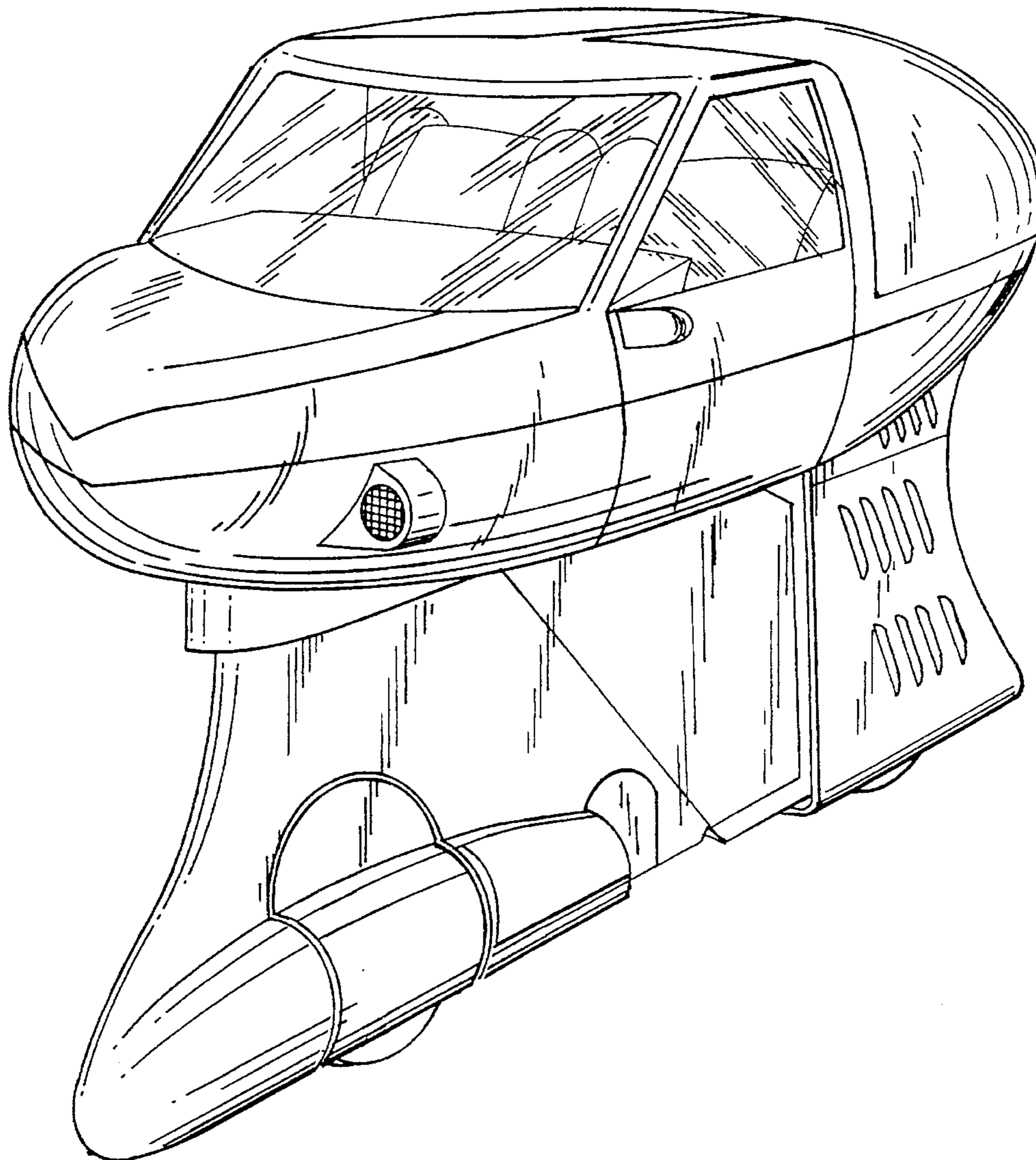

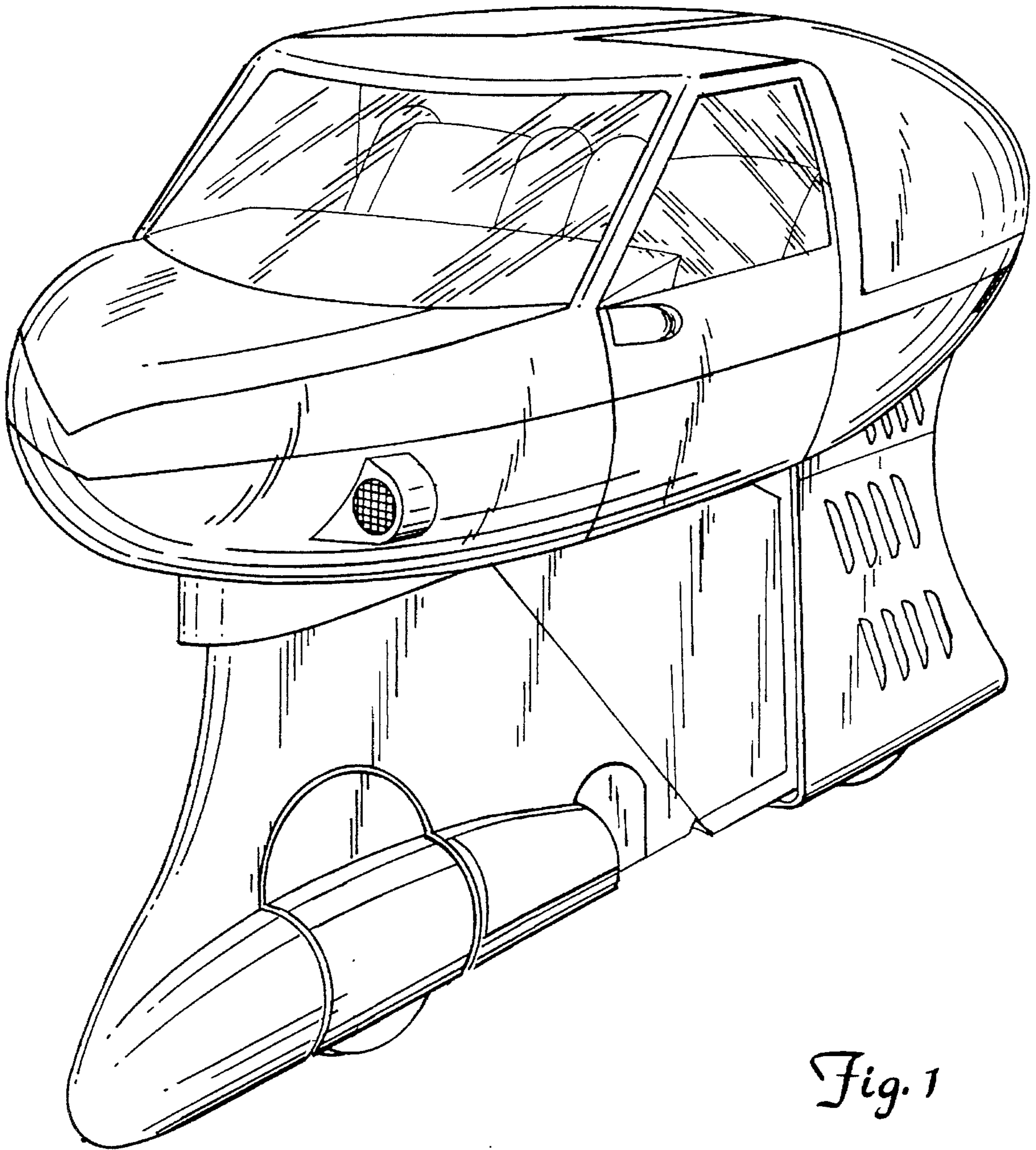

Fig. 1

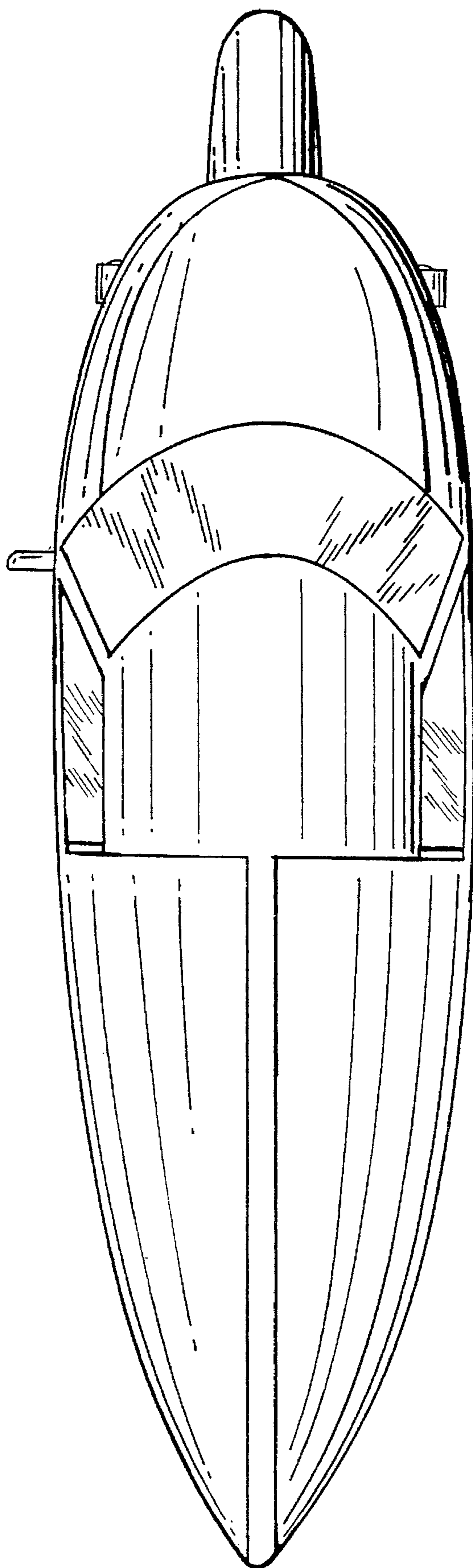

Fig. 2

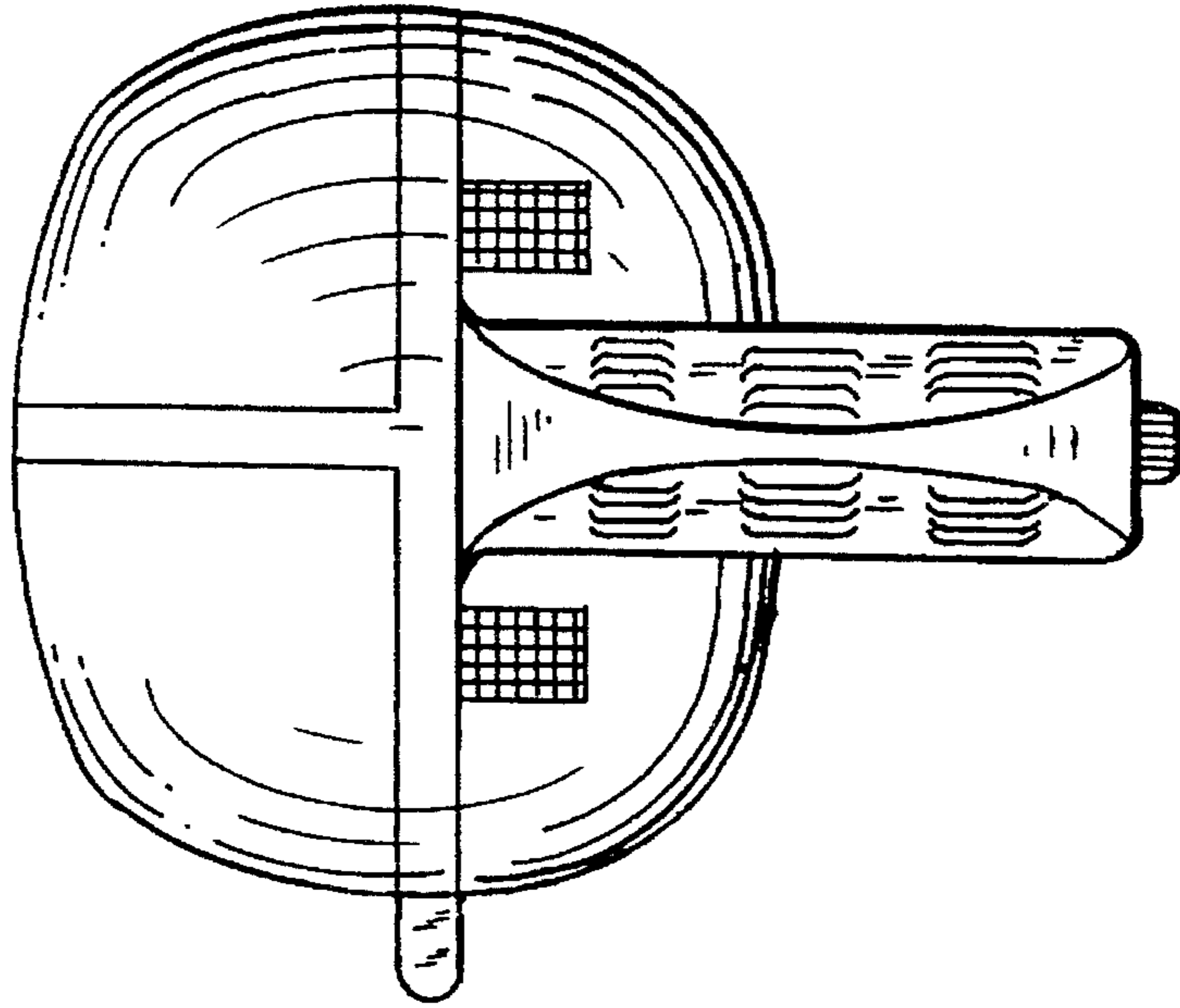

Fig. 5

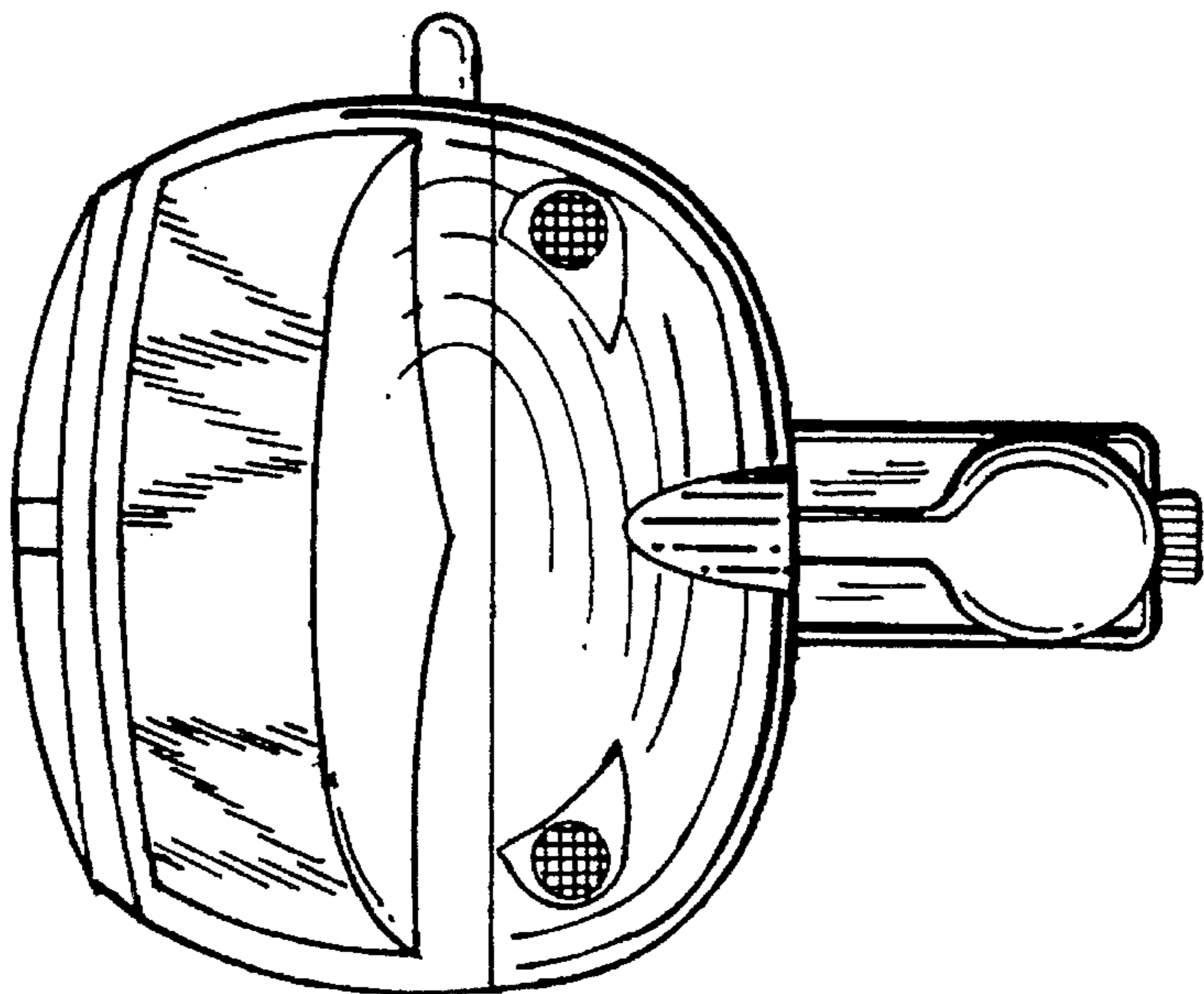

Fig. 3

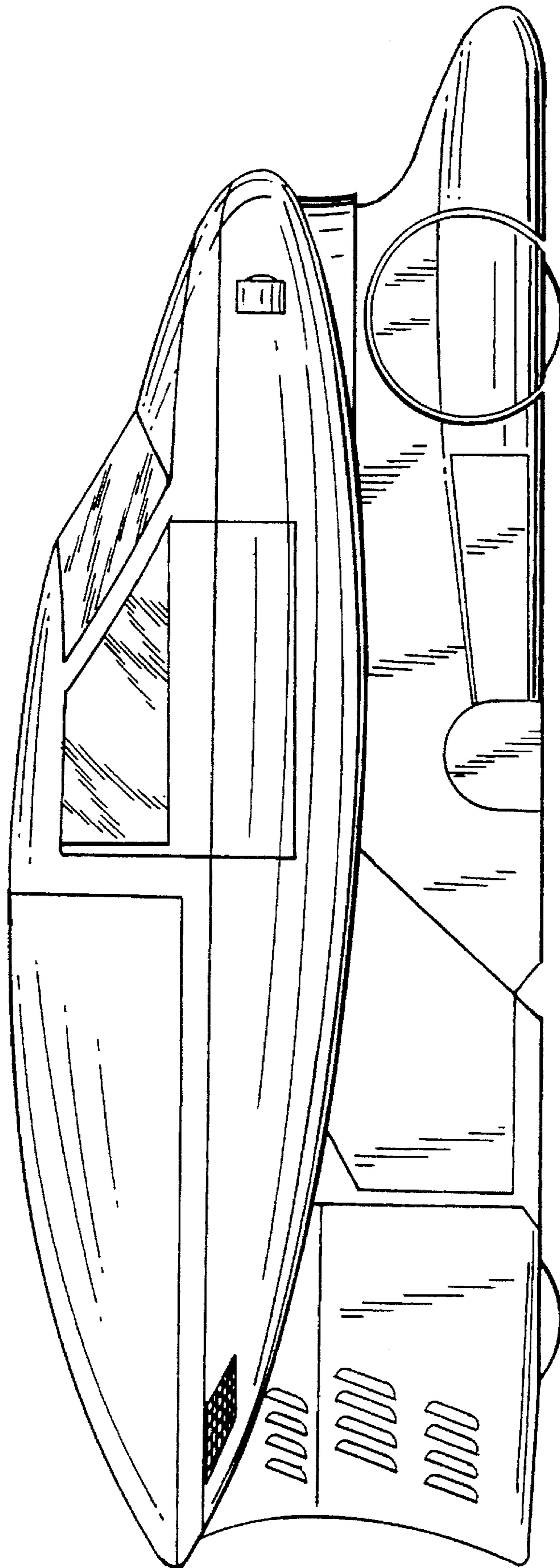

Fig. 4