



US00D371336S

United States Patent [19]

Wilson

[11] Patent Number: **Des. 371,336**

[45] Date of Patent: ****Jul. 2, 1996**

[54] **STEP FOR BOAT TRAILER**

4,911,264 3/1990 McCafferty .
4,943,076 7/1990 Tripke .

[76] Inventor: **Richard A. Wilson**, Lake Rd. 53-37,
P.O. Box 202, Osage Beach, Mo. 65065

Primary Examiner—A. Hugo Word
Assistant Examiner—Lavone Tabor
Attorney, Agent, or Firm—Paul M. Denk

[**] Term: **14 Years**

[21] Appl. No.: **31,289**

[57] **CLAIM**

[22] Filed: **Nov. 21, 1994**

The ornamental design for a step for boat trailer, as shown and described.

[52] U.S. Cl. **D12/203**

[58] Field of Search D12/203; 182/90,
182/92, 228; 280/163, 164.1, 164.2; D25/62,
68, 69; 52/177, 179

DESCRIPTION

FIG. 1 is an isometric view showing the step for boat trailer of this design, the broken lines showing of a boat and trailer are for illustrative purposes only, and form no part of the claimed design;

FIG. 2 is a top plan view of the step for boat trailer;

FIG. 3 is a bottom view thereof;

FIG. 4 is a right side view, the left side view being a mirror image thereof;

FIG. 5 is an exploded isometric view thereof;

FIG. 6 is a front view thereof; and,

FIG. 7 is a rear view thereof.

[56] **References Cited**

U.S. PATENT DOCUMENTS

D. 313,388	1/1991	Dale .	
455,639	7/1891	Roden .	
3,017,949	1/1962	Harlan	182/92
3,794,345	2/1974	Locke	280/163
4,056,270	11/1977	Greenfield .	
4,405,141	9/1983	Jurek .	
4,605,098	8/1986	Leuty .	
4,753,447	6/1988	Hall .	

1 Claim, 2 Drawing Sheets

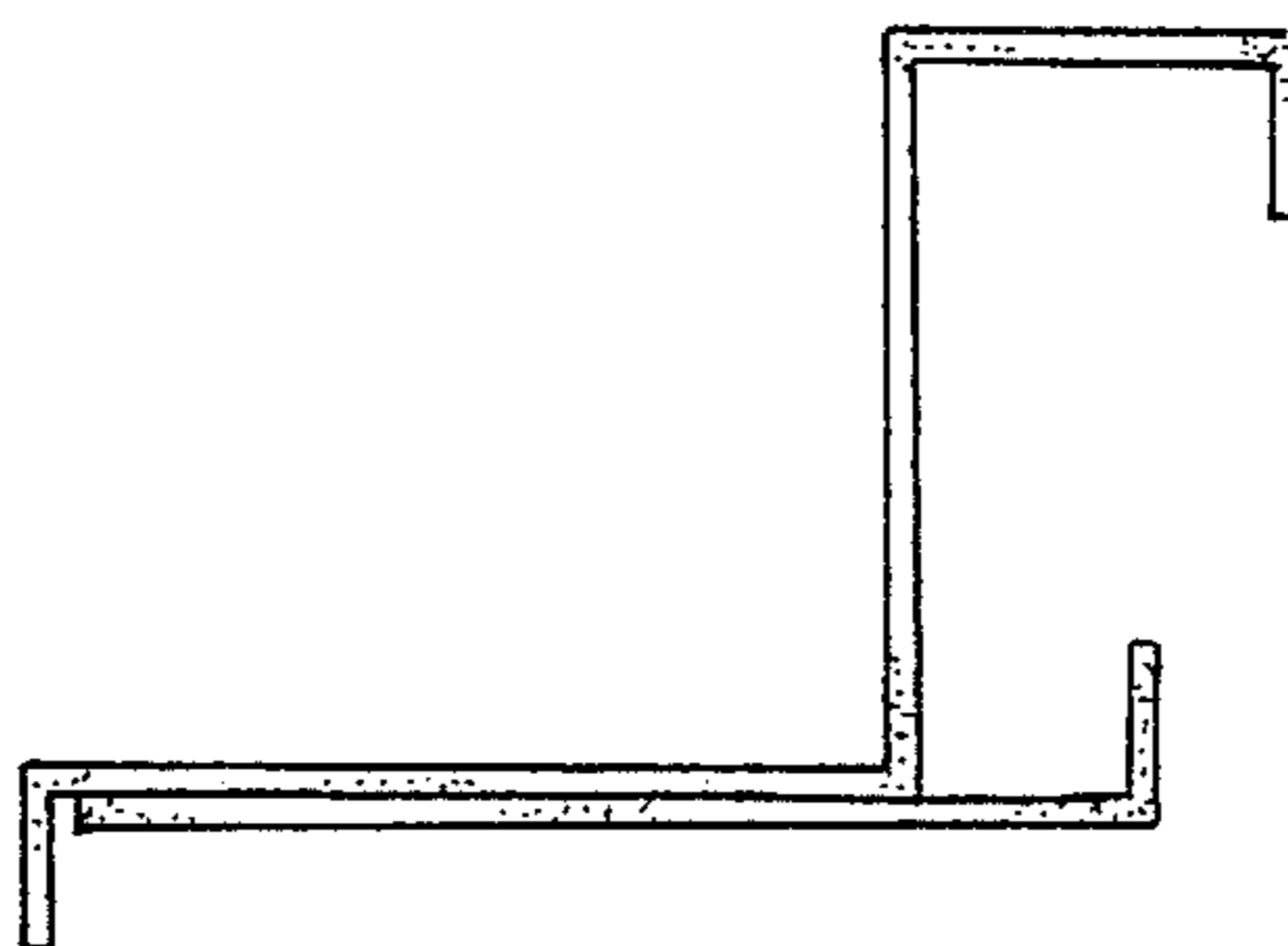
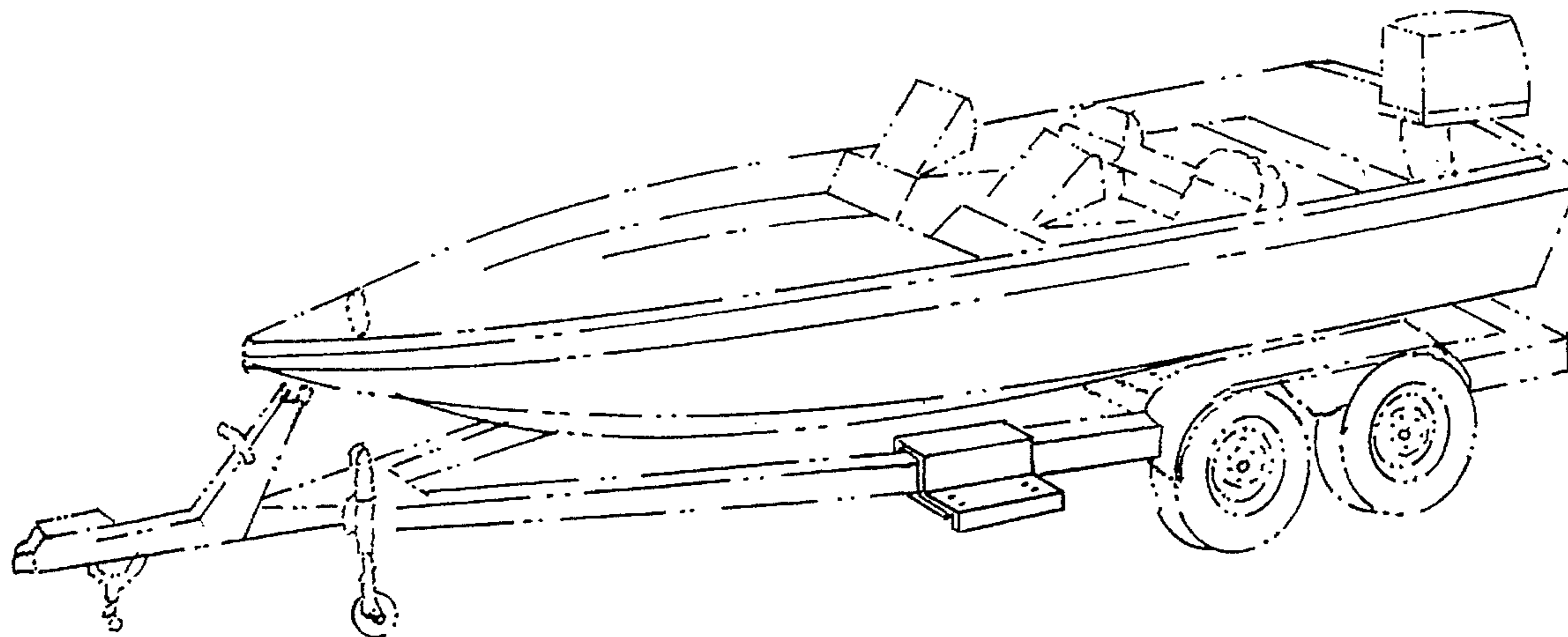

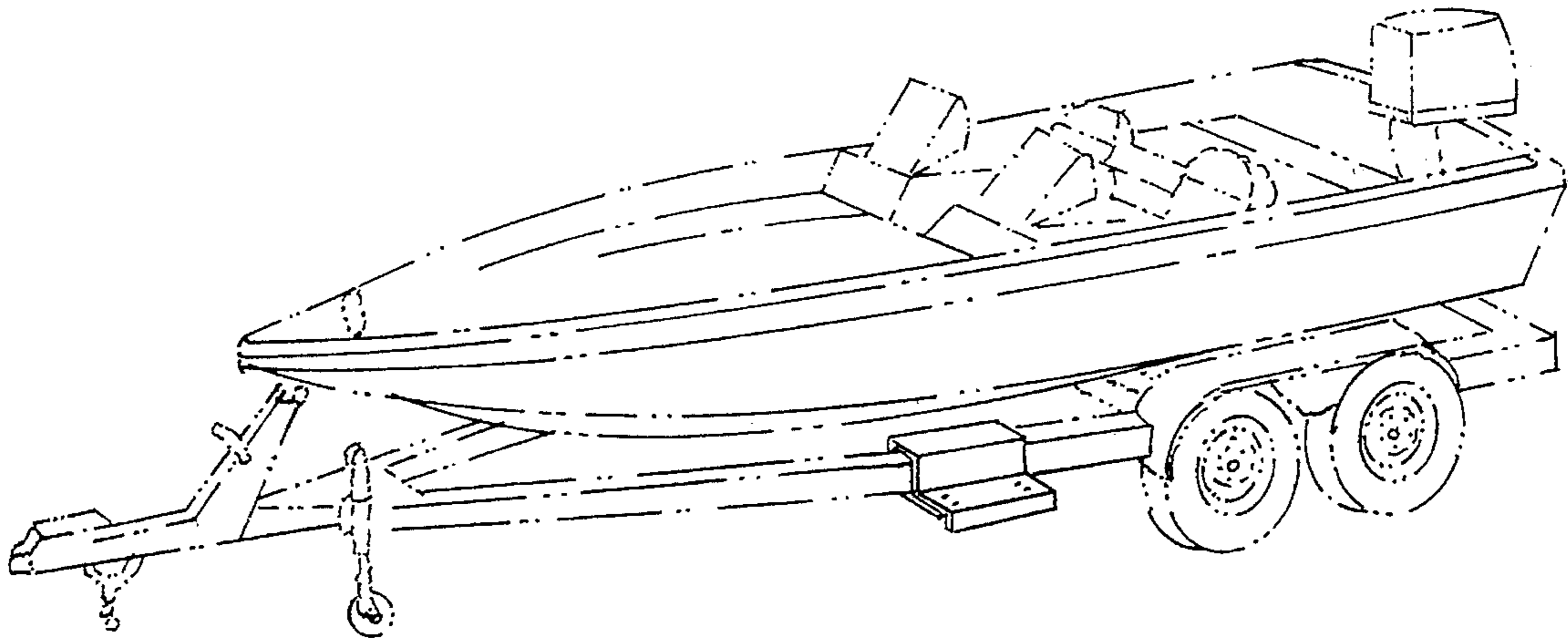

FIG. 1

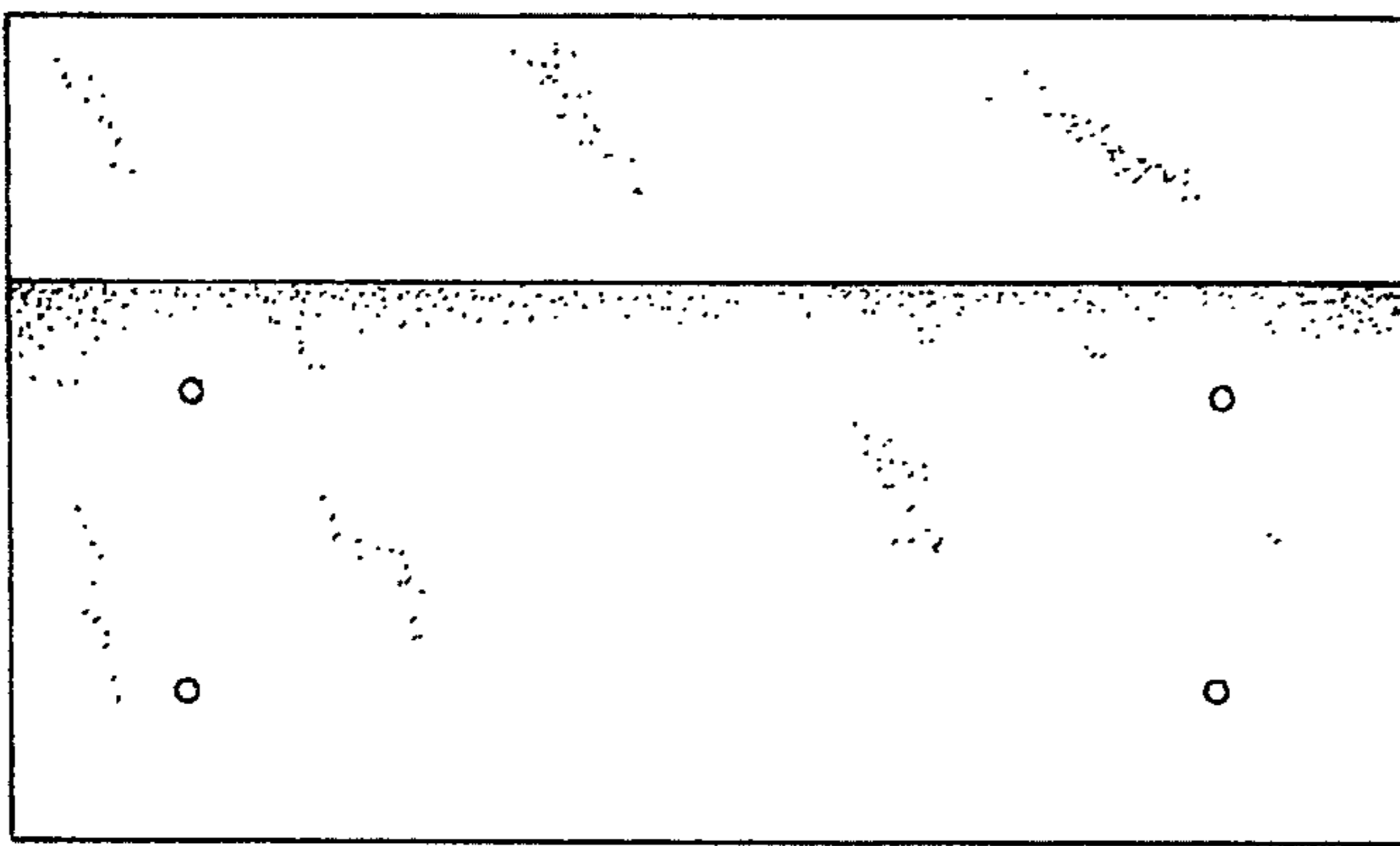

FIG. 2

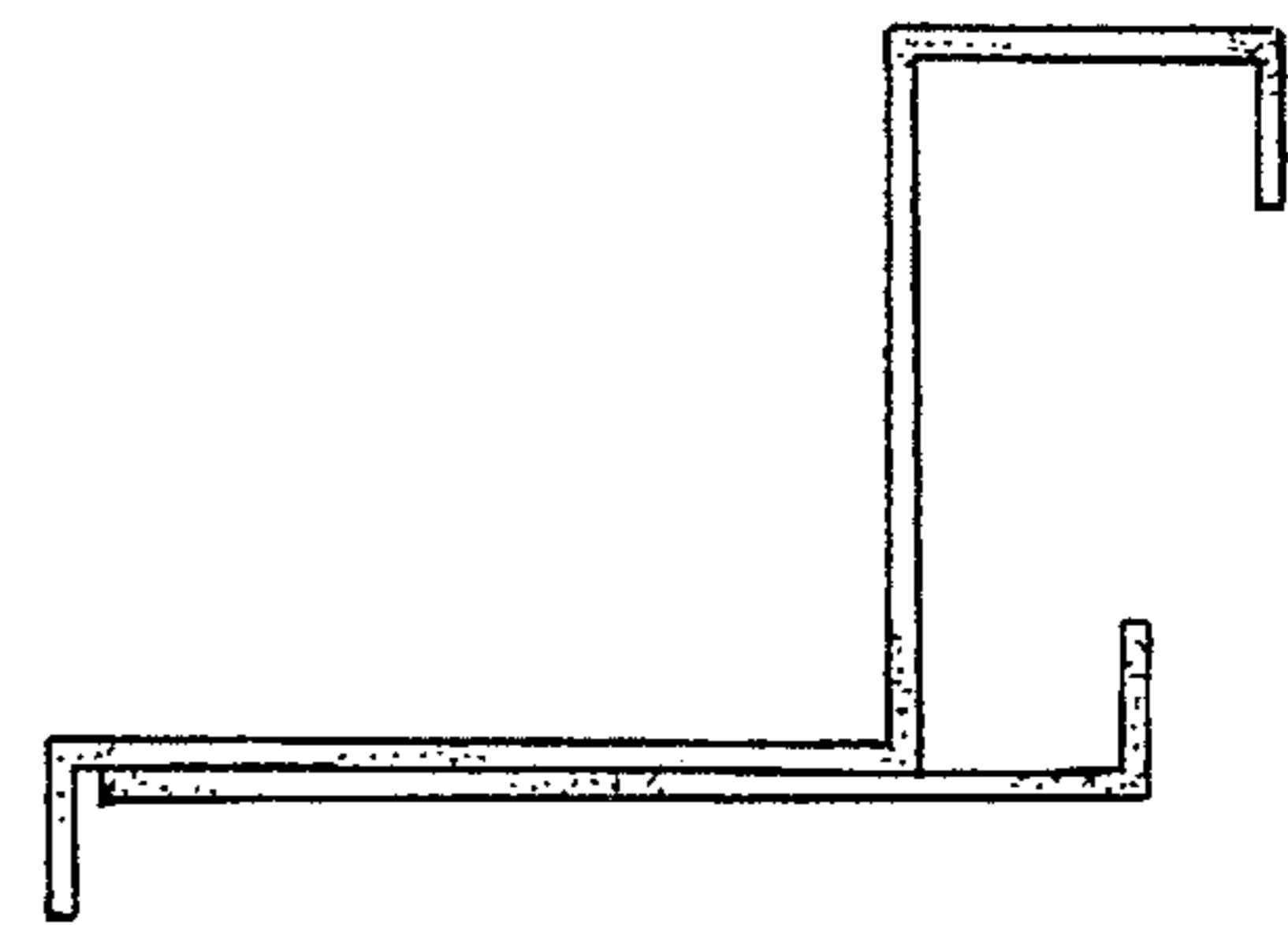

FIG. 4

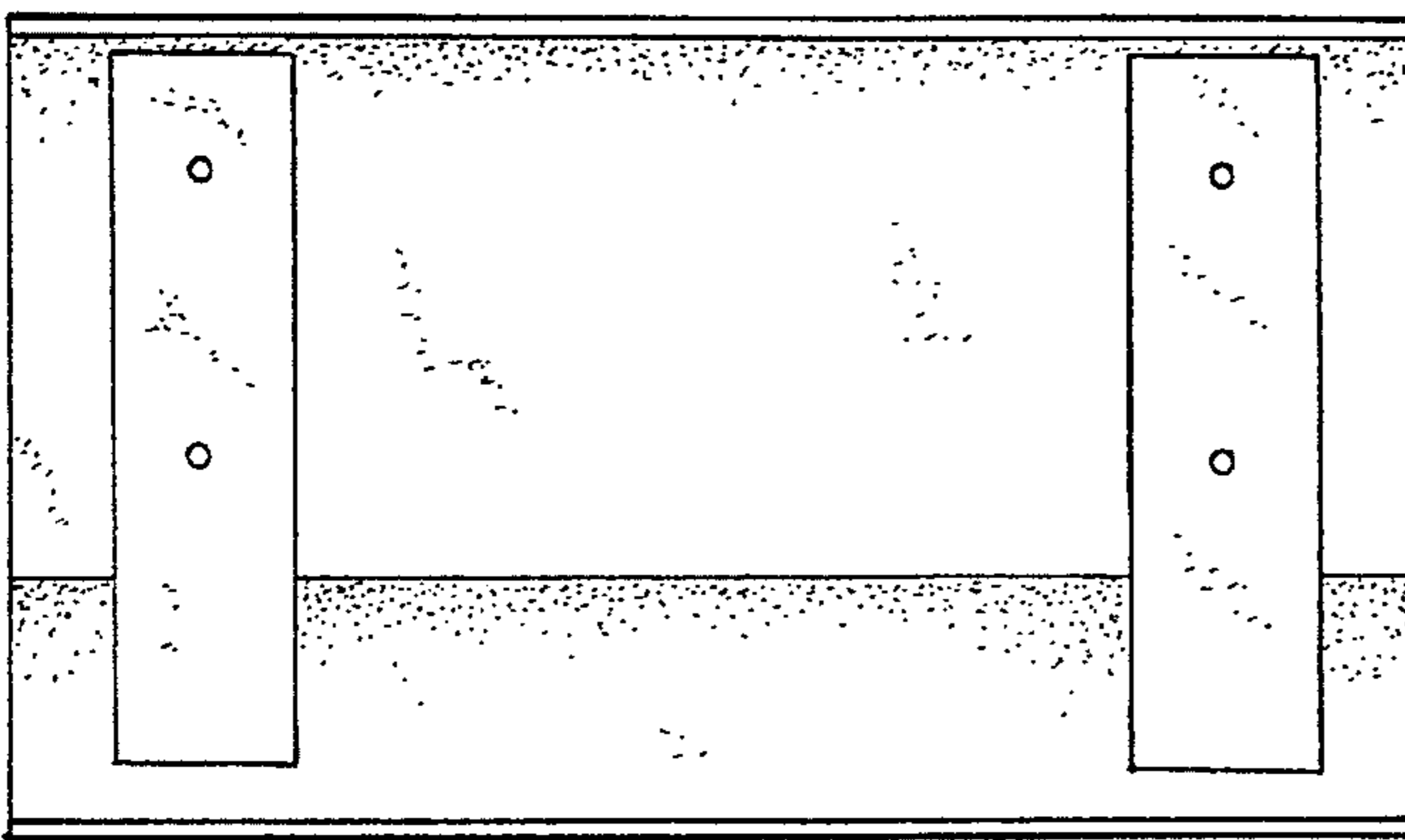

FIG. 3

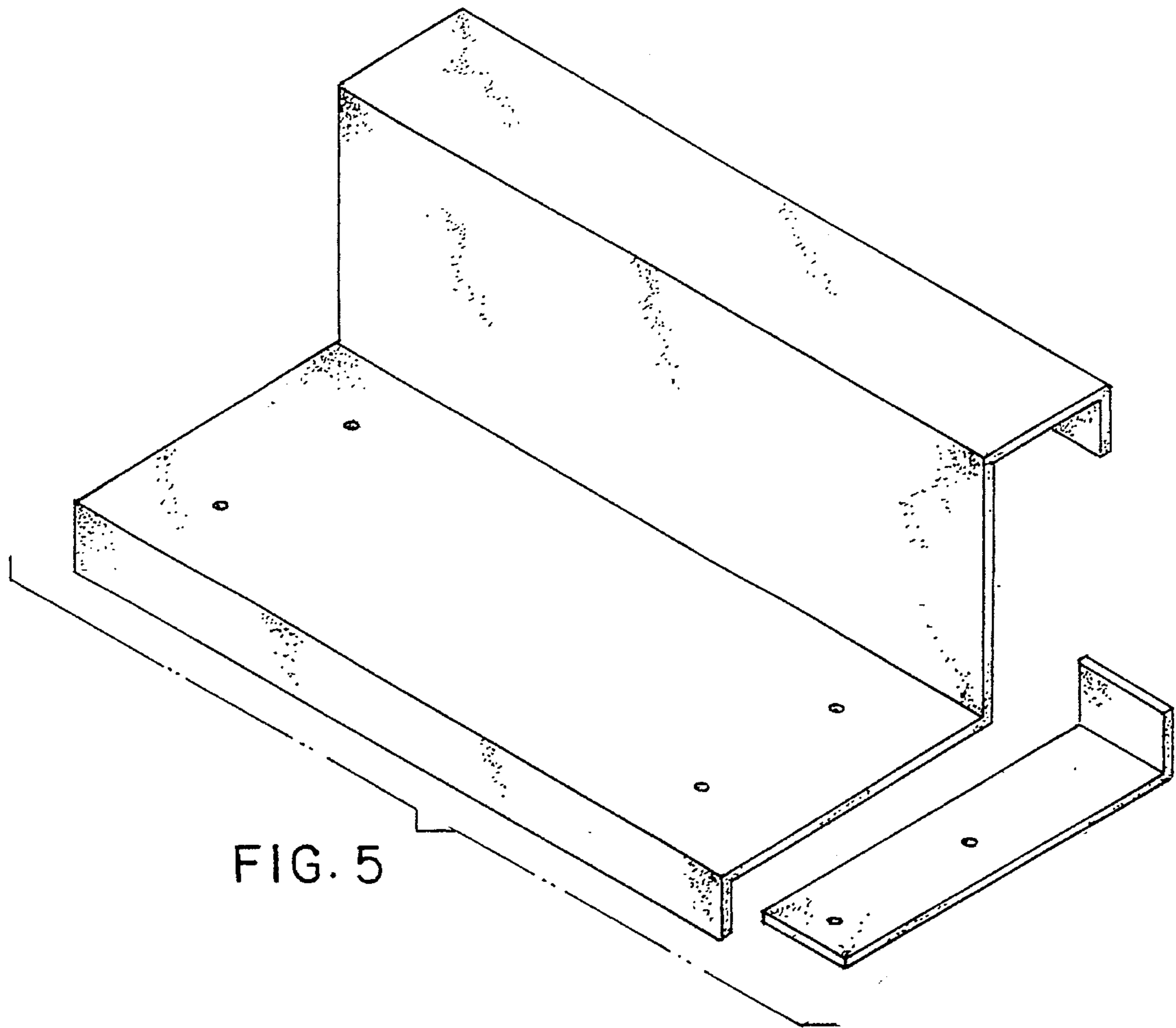

FIG. 5

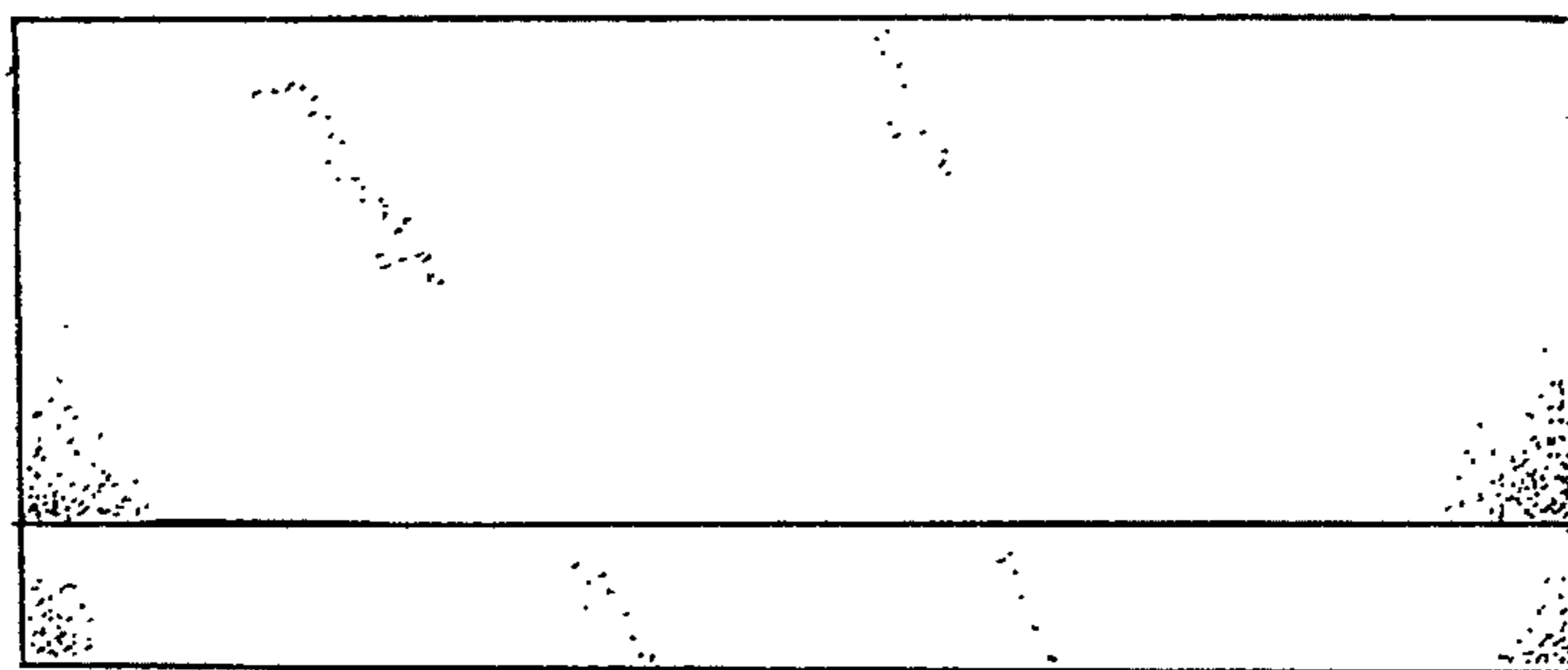

FIG. 6

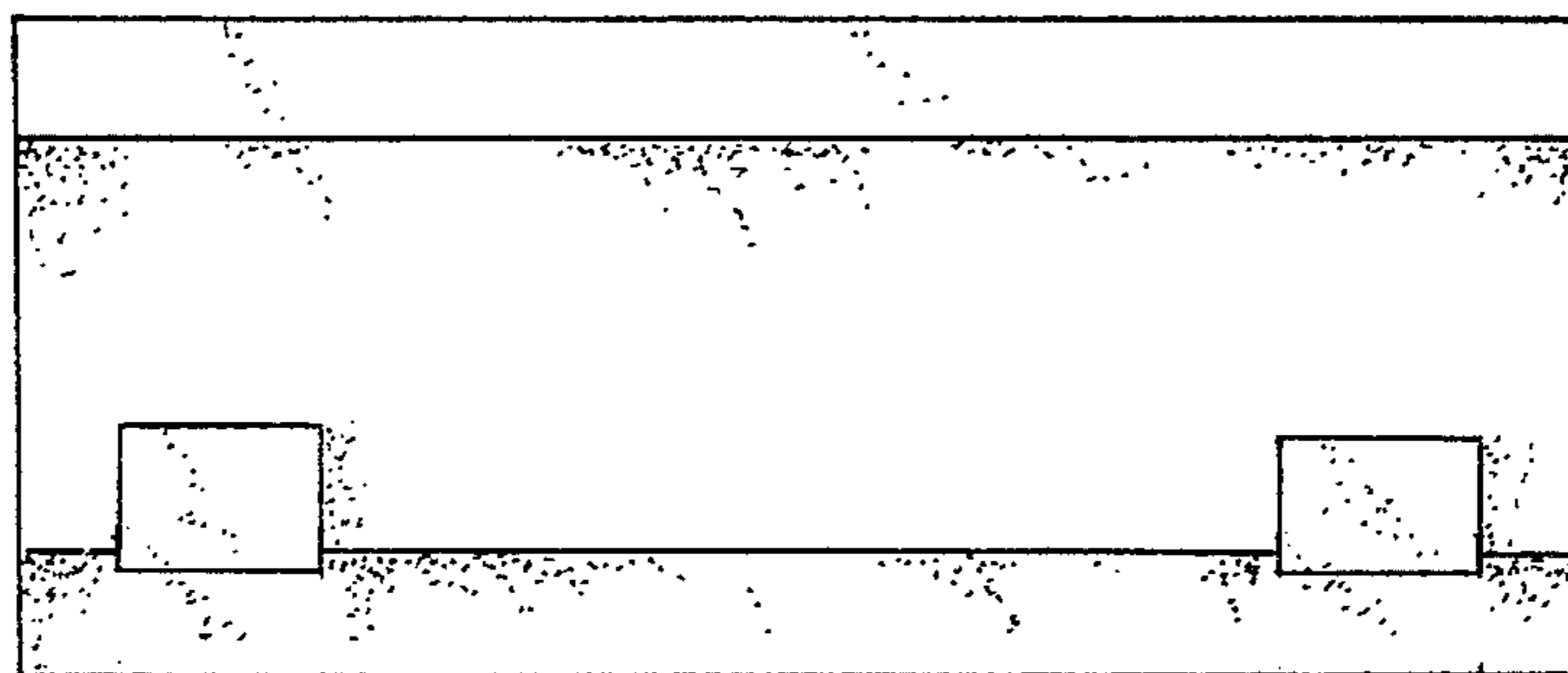

FIG. 7