



US00D371290S

United States Patent [19]
Ozark

[11] **Patent Number: Des. 371,290**
[45] **Date of Patent: **Jul. 2, 1996**

[54] **VEHICLE WINDOW LATCH HANDLE**

OTHER PUBLICATIONS

[75] Inventor: **John Ozark**, Grosse Pointe Woods, Mich.

Undated photograph depicting window latch for the 1986 Chevrolet Full-Size Van.

[73] Assignee: **Chrysler Corporation**, Highland Park, Mich.

Primary Examiner—Dominic Simone
Attorney, Agent, or Firm—Mark P. Calcaterra

[**] Term: **14 Years**

[57] **CLAIM**

[21] Appl. No.: **28,936**

The ornamental design for a vehicle window latch handle, as shown and described.

[22] Filed: **Sep. 26, 1994**

DESCRIPTION

[52] **U.S. Cl.** **D8/307**

[58] **Field of Search** D8/300, 307, 308;
16/110 R, 114 R, 111 R, 125, 127; 292/DIG. 6, DIG. 68

FIG. 1 is a to side perspective view of a vehicle window latch handle showing my new design, the partially broken away vehicle window shown in broken lines for illustrative purposes only;

FIG. 2 is a top plan view thereof;

FIG. 3 is a bottom plan view thereof;

FIG. 4 is a left side elevational view thereof, the right side being a mirror image;

FIG. 5 is a front elevational view thereof; and,

FIG. 6 is a rear elevational view thereof.

[56] **References Cited**

U.S. PATENT DOCUMENTS

D. 218,279	8/1970	Chaumont	D8/308
D. 254,772	4/1980	Buck, Jr.	D8/308
2,202,393	5/1940	Morrison	292/DIG. 6 X
2,837,362	6/1958	Meyer	292/DIG. 6 X
4,124,239	11/1978	Morton	292/DIG. 6 X

1 Claim, 2 Drawing Sheets

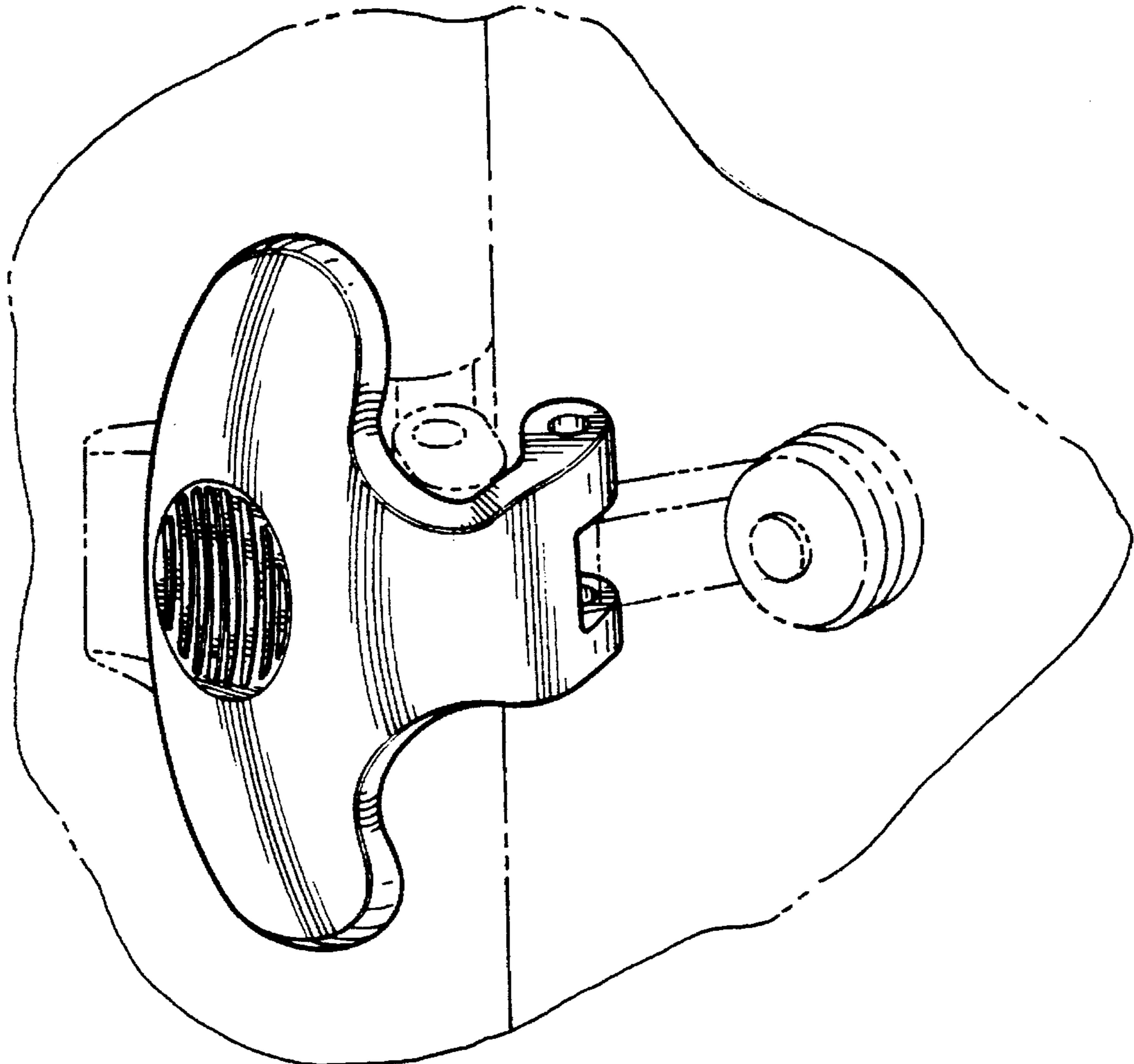

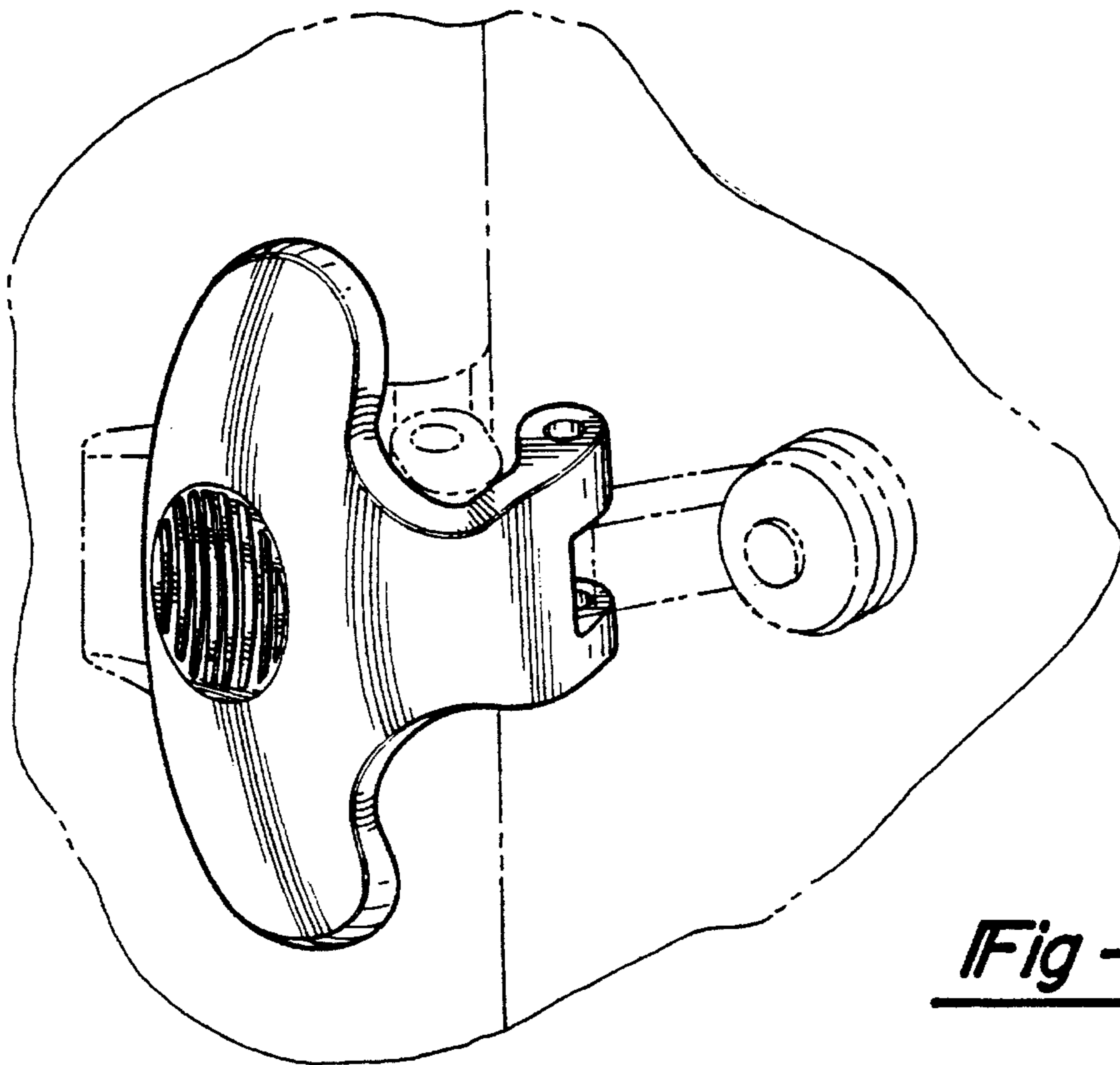

Fig - 1

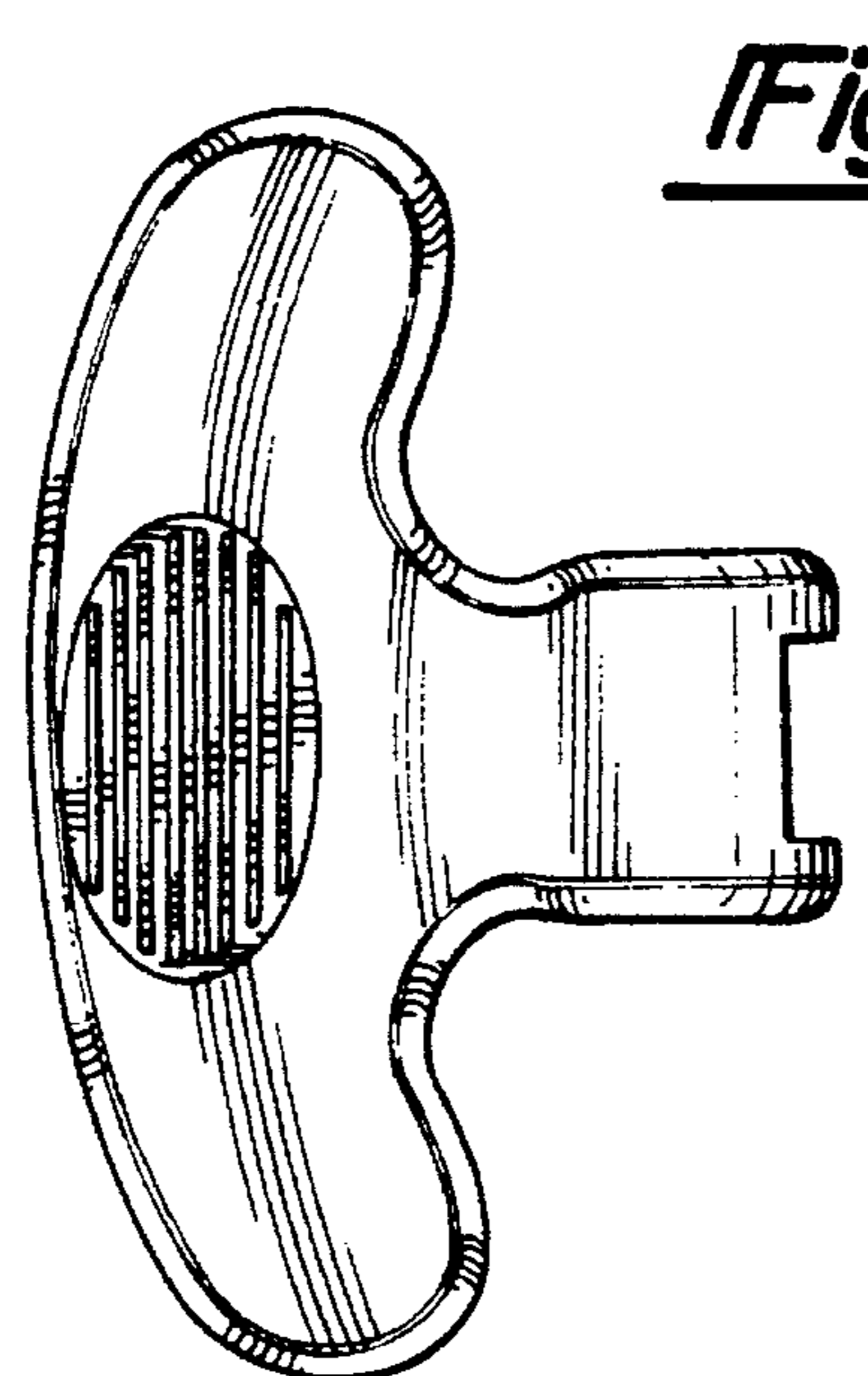

Fig - 2

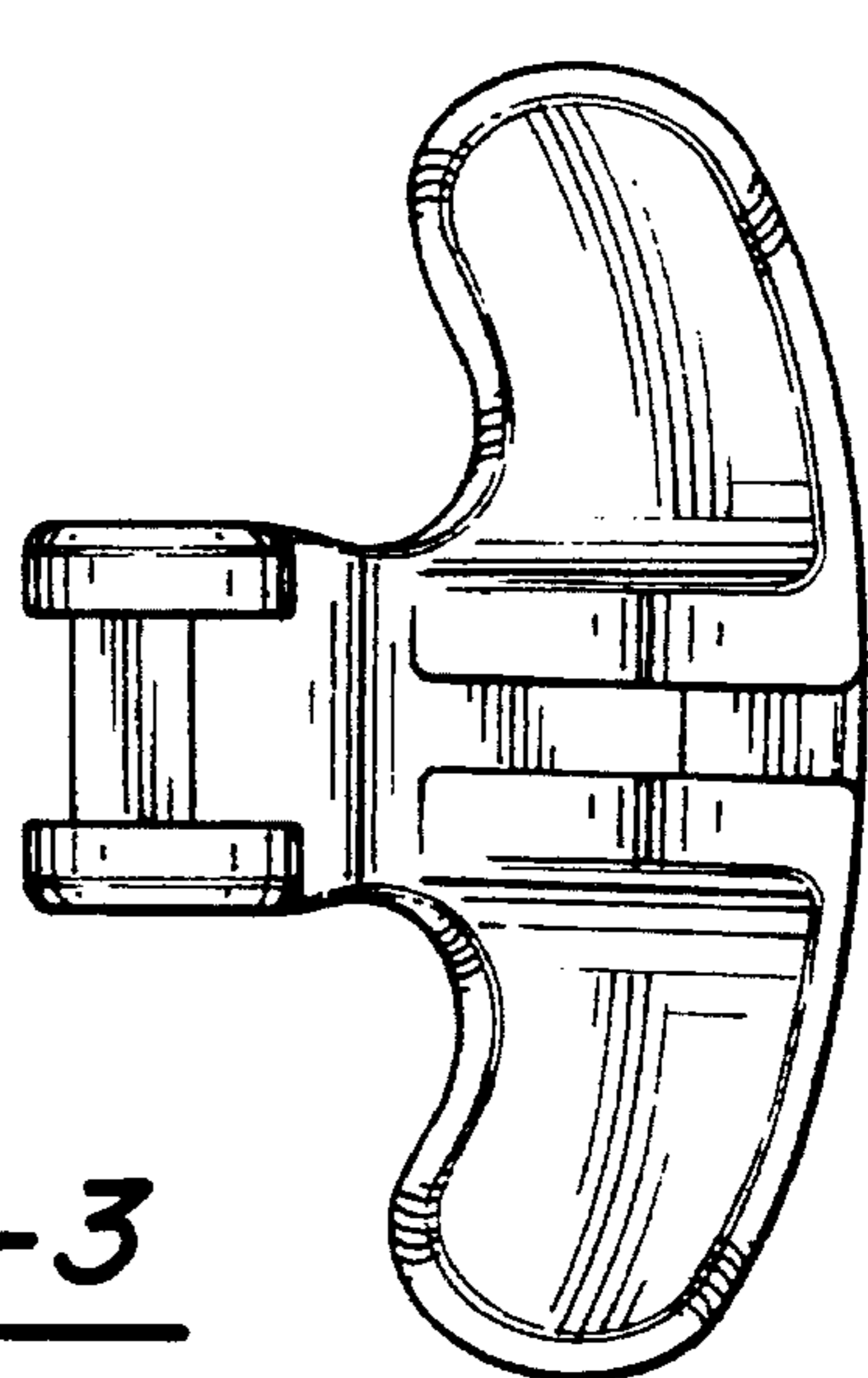

Fig - 3

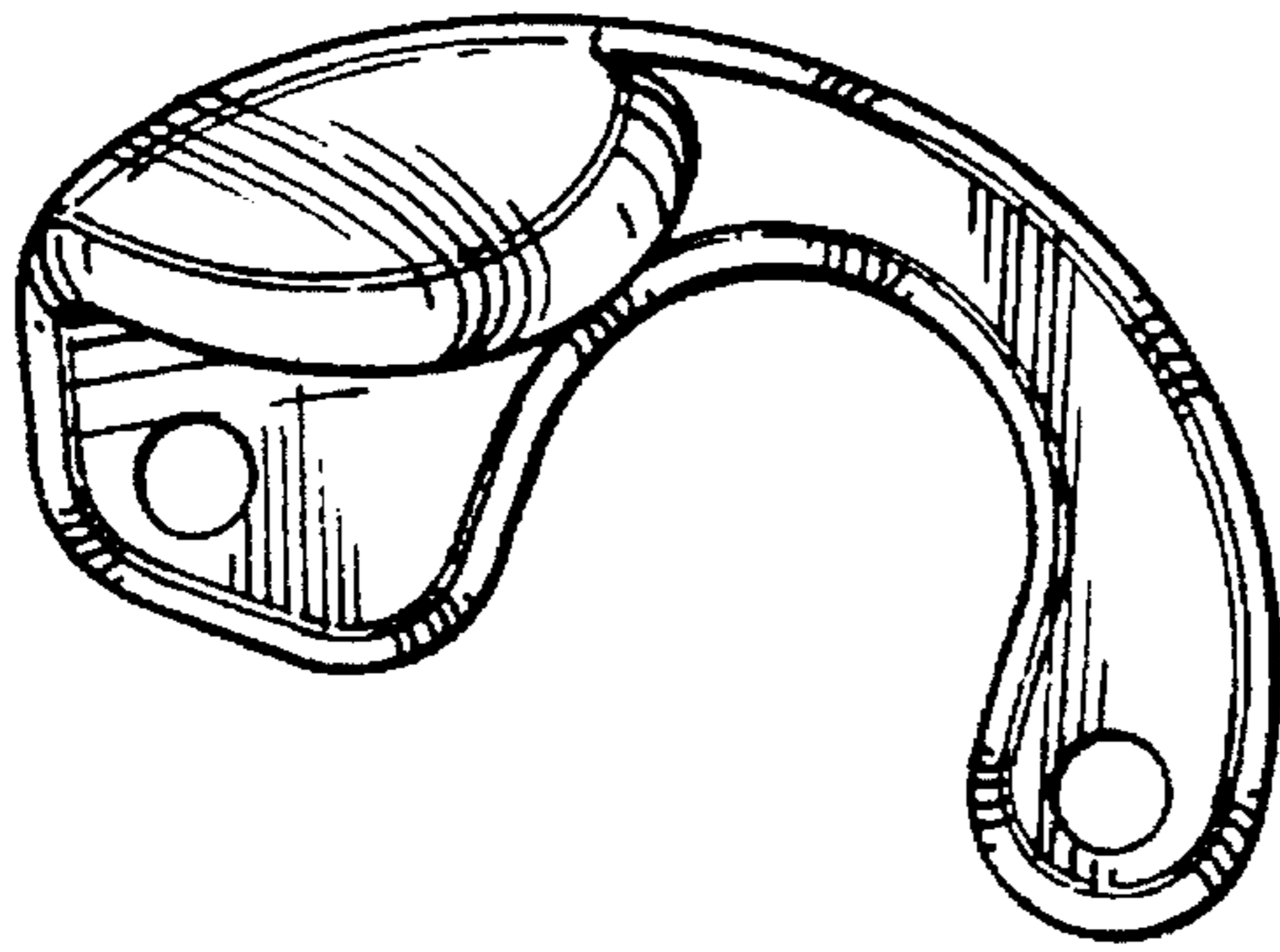

Fig - 4

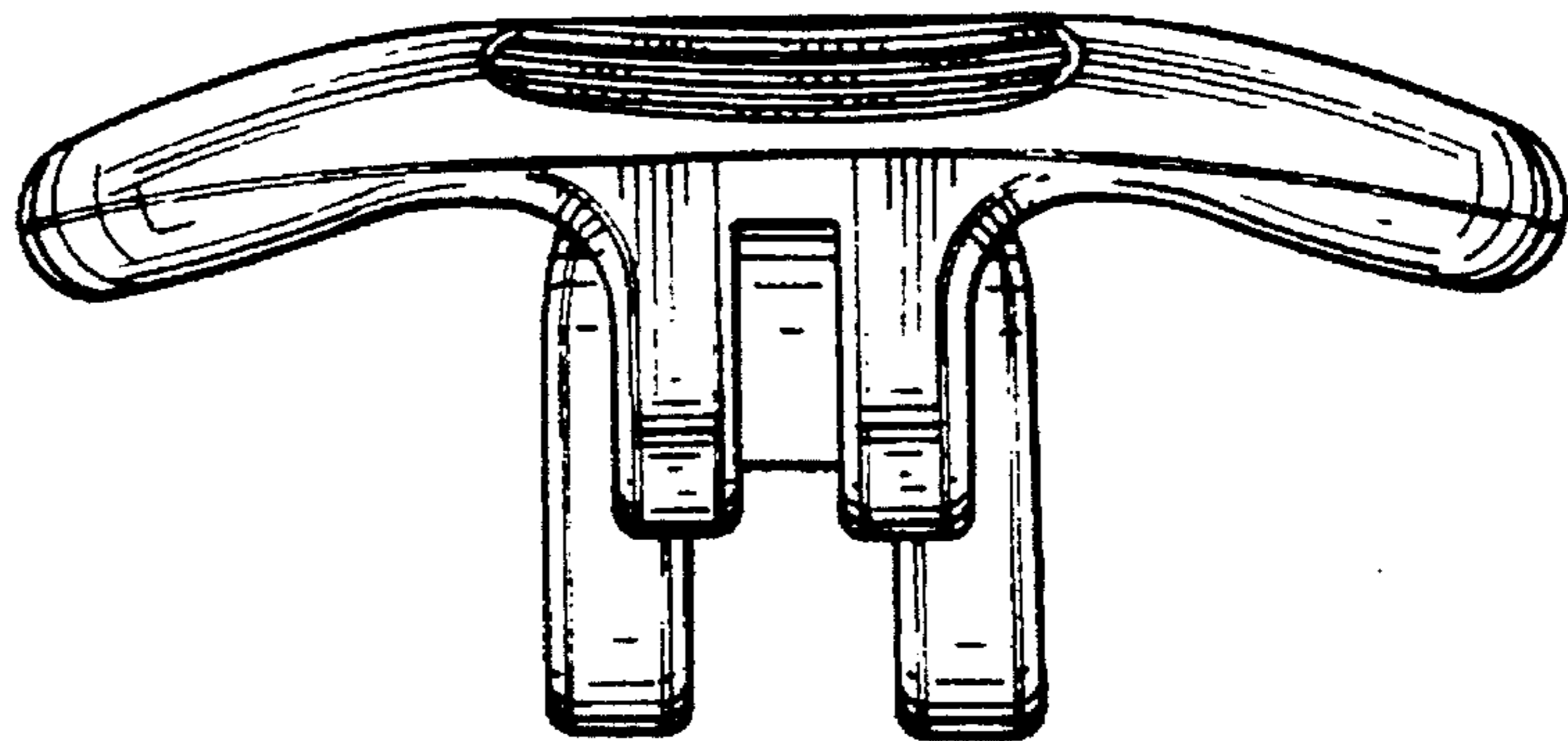

Fig - 5

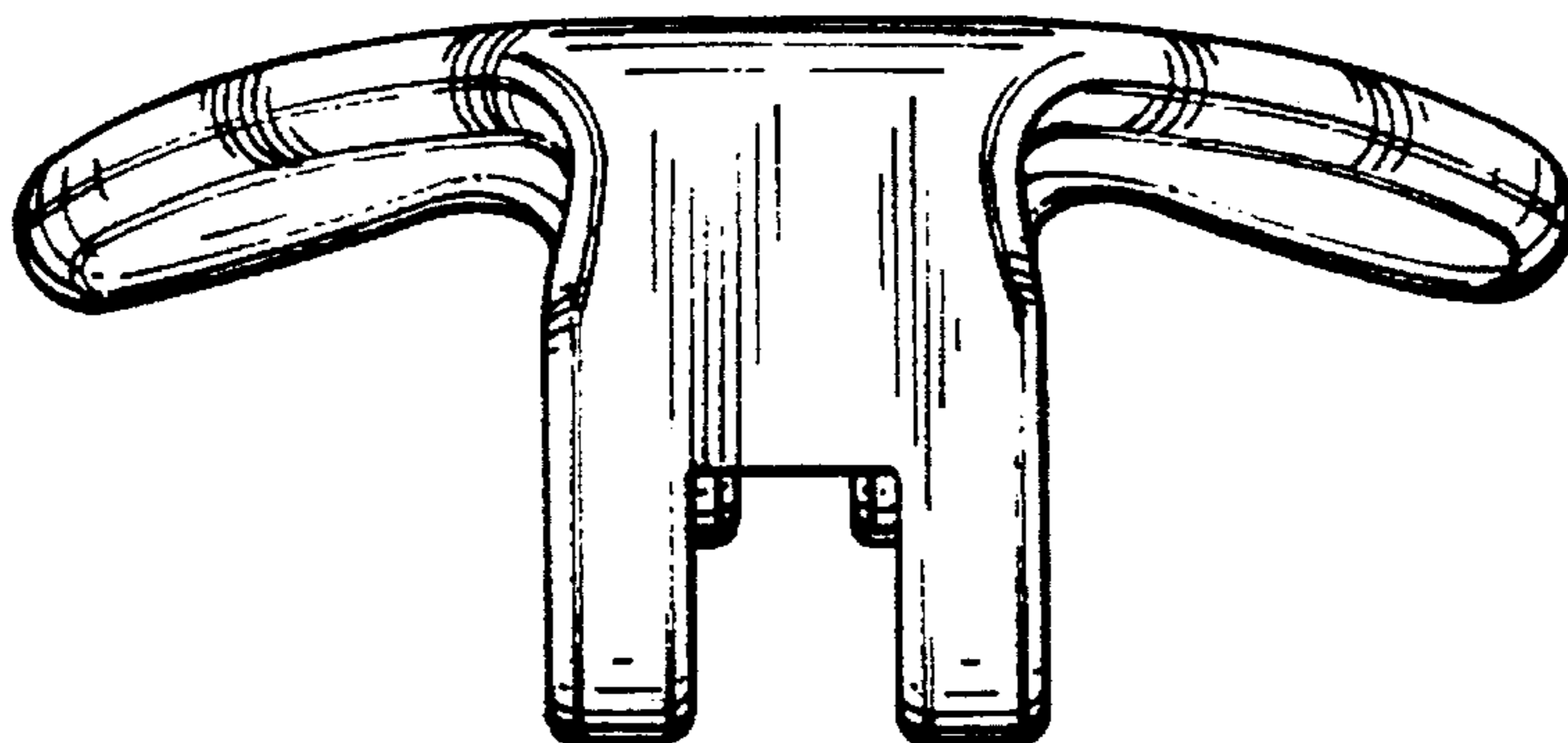

Fig - 6