



US00D371143S

# United States Patent [19]

[11] Patent Number: **Des. 371,143**

Hagerman

[45] Date of Patent: **\*\*Jun. 25, 1996**

[54] **COMPOSITE TIRE AND TIRE ELEMENT**

4,074,942 2/1978 Cochran ..... 301/43  
4,861,120 8/1989 Edwards et al. .... 305/35 R

[75] Inventor: **Robert L. Hagerman**, Aurora, Canada

*Primary Examiner*—Sandra L. Morris  
*Attorney, Agent, or Firm*—Handal & Morofsky

[73] Assignee: **Airboss of America Corp.**,  
Mississauga, Canada

[57] **CLAIM**

[\*\*] Term: **14 Years**

The ornamental design for a composite tire and tire element,  
as shown.

[21] Appl. No.: **27,370**

### DESCRIPTION

[22] Filed: **Aug. 19, 1994**

[52] U.S. Cl. .... **D15/28**

[58] **Field of Search** ..... D12/135, 149,  
D12/151, 154; D15/10, 28; 152/209 A,  
209 WT, 523; 301/43-44.4; 305/35 R, 35 EB,  
39

FIG. 1 is a reduced perspective view of a composite tire and  
tire element, showing my new design, the broken line  
showing of the tire is for illustrative purposes only to  
indicate that the tire comprises multiple similar tire elements  
disposed in a circle, and forms no part of the claimed design;  
FIG. 2 is a side perspective view of the tire element of FIG.  
1;

### [56] **References Cited**

#### U.S. PATENT DOCUMENTS

D. 309,254	7/1990	Guile	.....	D12/135
D. 323,312	1/1992	Tandy	.....	D12/154
D. 342,526	12/1993	Chandler	.....	D15/28
1,118,914	12/1914	Beauchemin	.....	301/44.4
1,178,074	4/1916	Howard	.....	301/44.4
1,380,137	5/1921	Donohue	.....	301/44.4
1,470,819	10/1923	Eder	.....	301/44.4
1,938,041	9/1931	Rober	.....	301/44.1
3,045,737	7/1962	Perlmutter	.....	D12/154

FIG. 3 is a top perspective from above and in front of the tire  
element of FIG. 1;  
FIG. 4 is a top perspective view from above and behind the  
tire element of FIG. 1;  
FIG. 5 is a side view of the other side of the tire element of  
FIG. 2;  
FIG. 6 is a top plan view of the tire element of FIG. 1;  
FIG. 7 is a bottom plan view of the tire element of FIG. 1;  
and,  
FIG. 8 is a side elevation of the tire element shown in FIG.  
1, in the direction of FIG. 2.

**1 Claim, 5 Drawing Sheets**

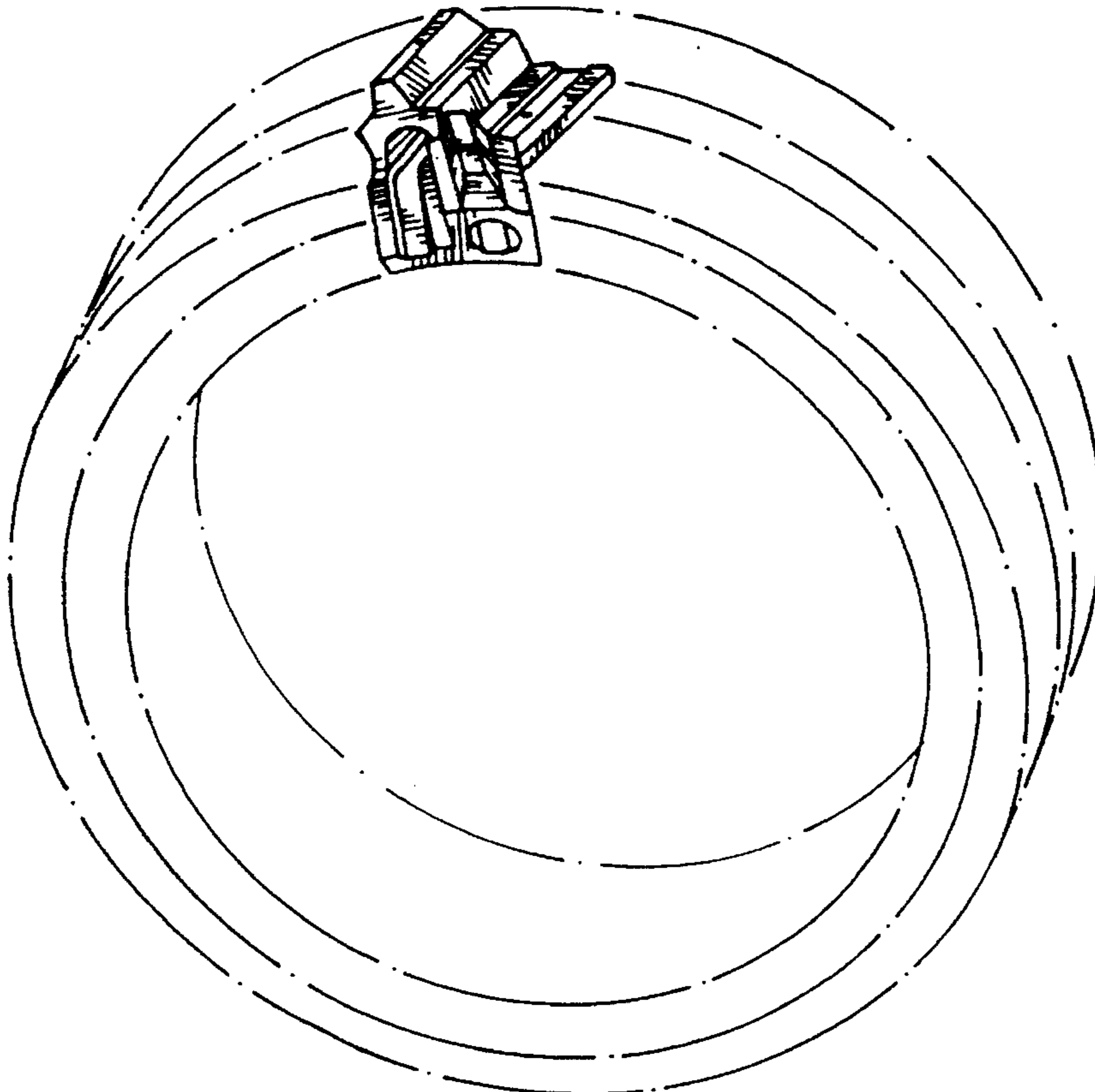

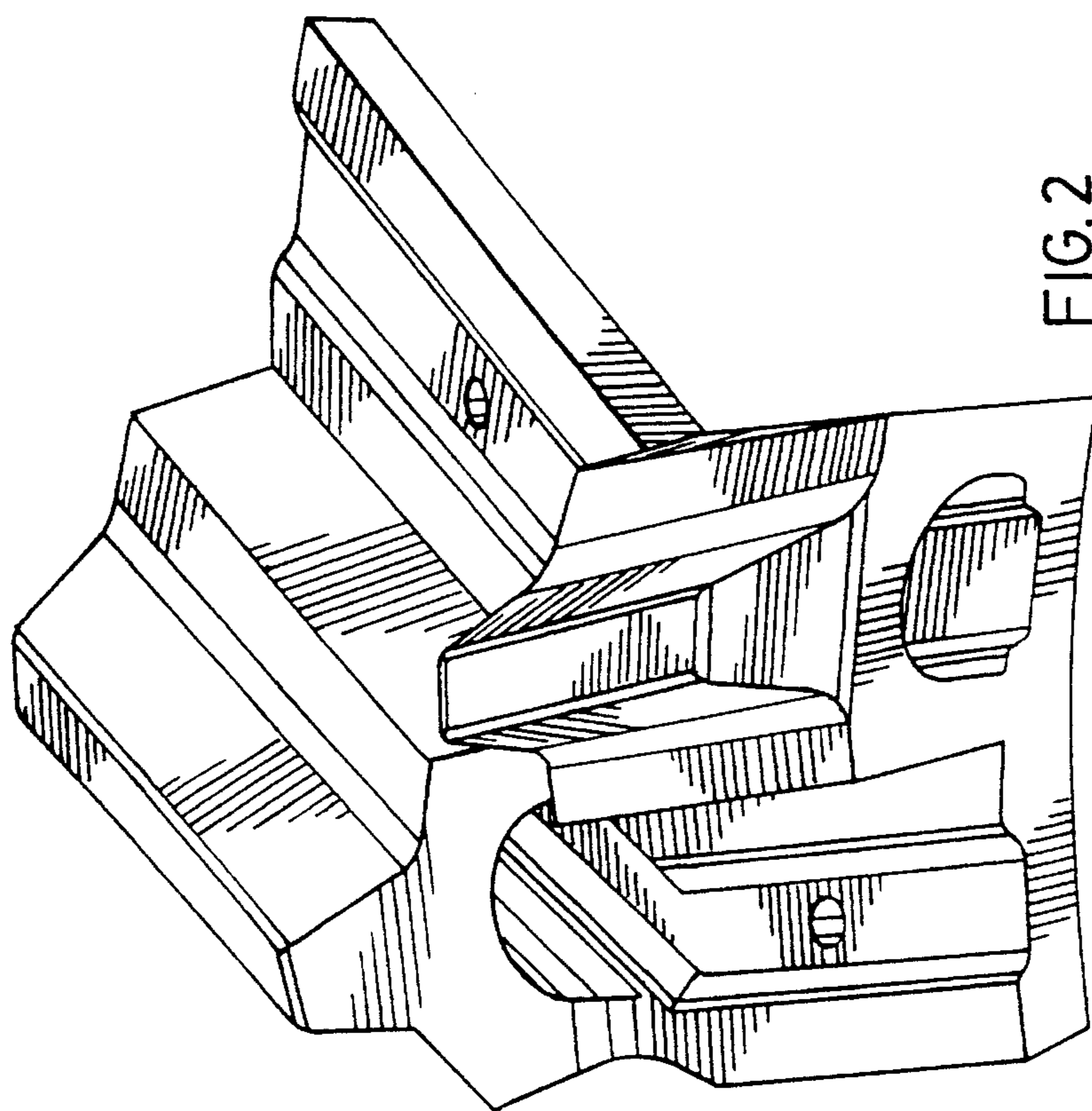

FIG. 2

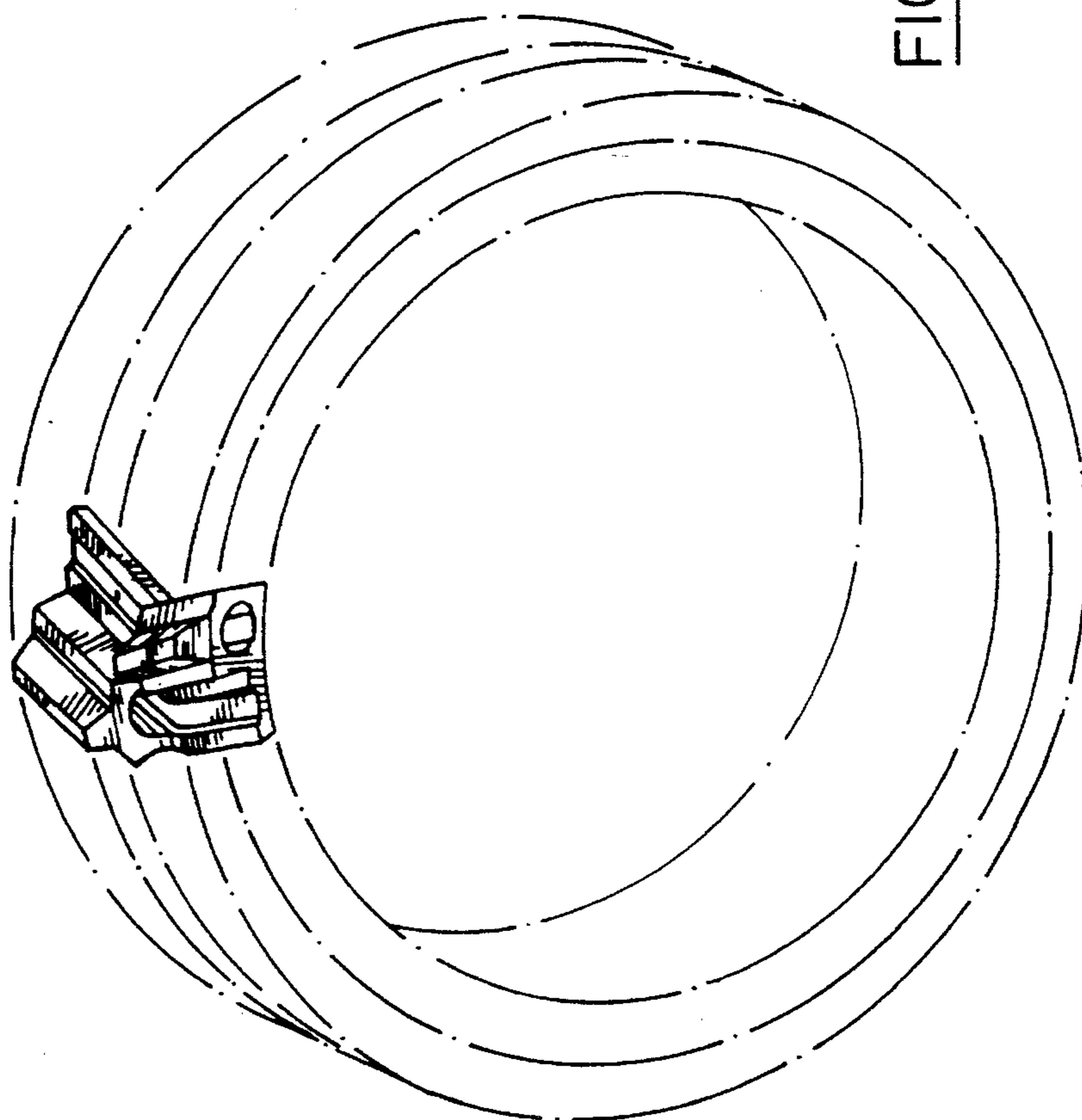

FIG. 1

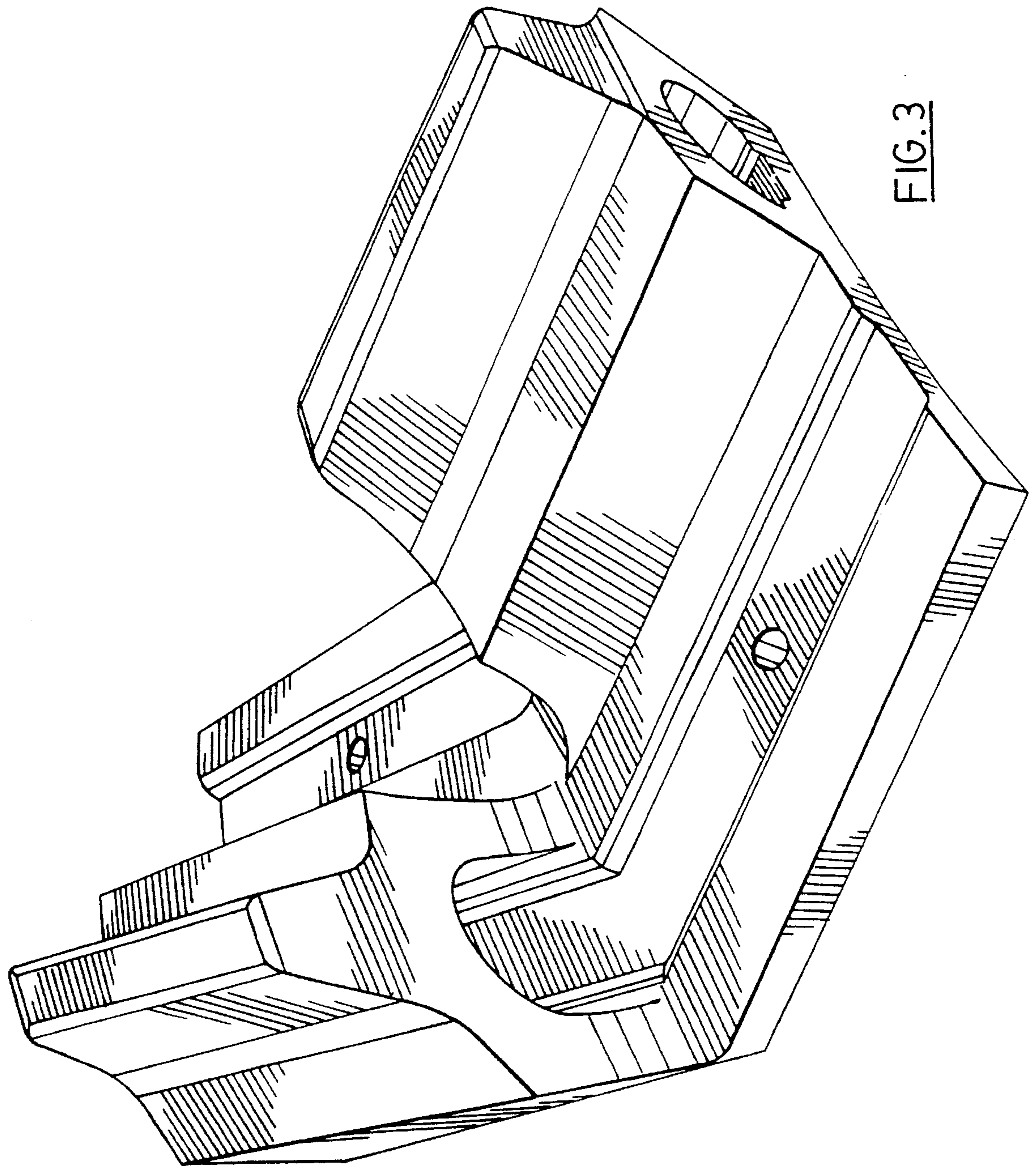

FIG. 3

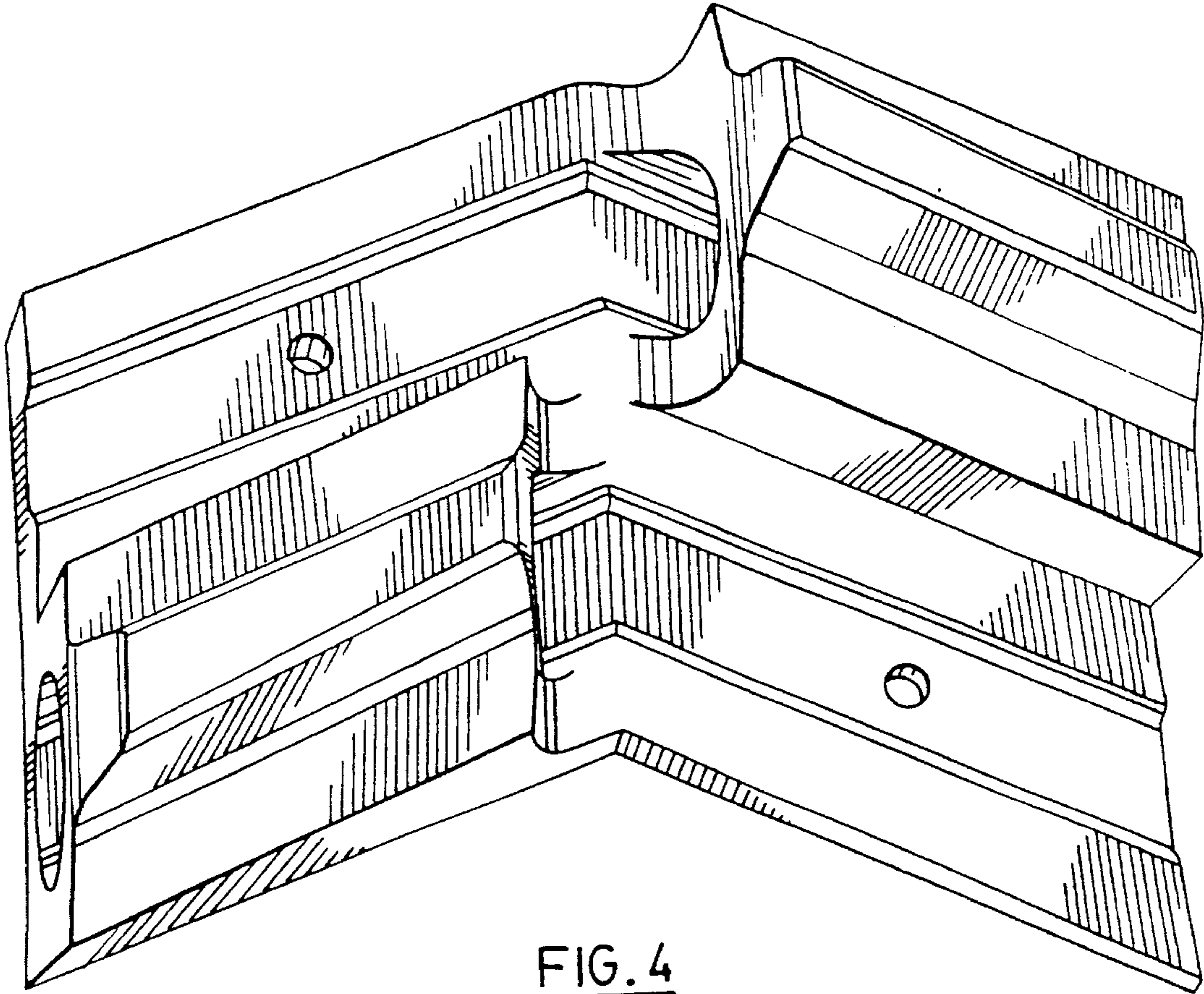

FIG. 4

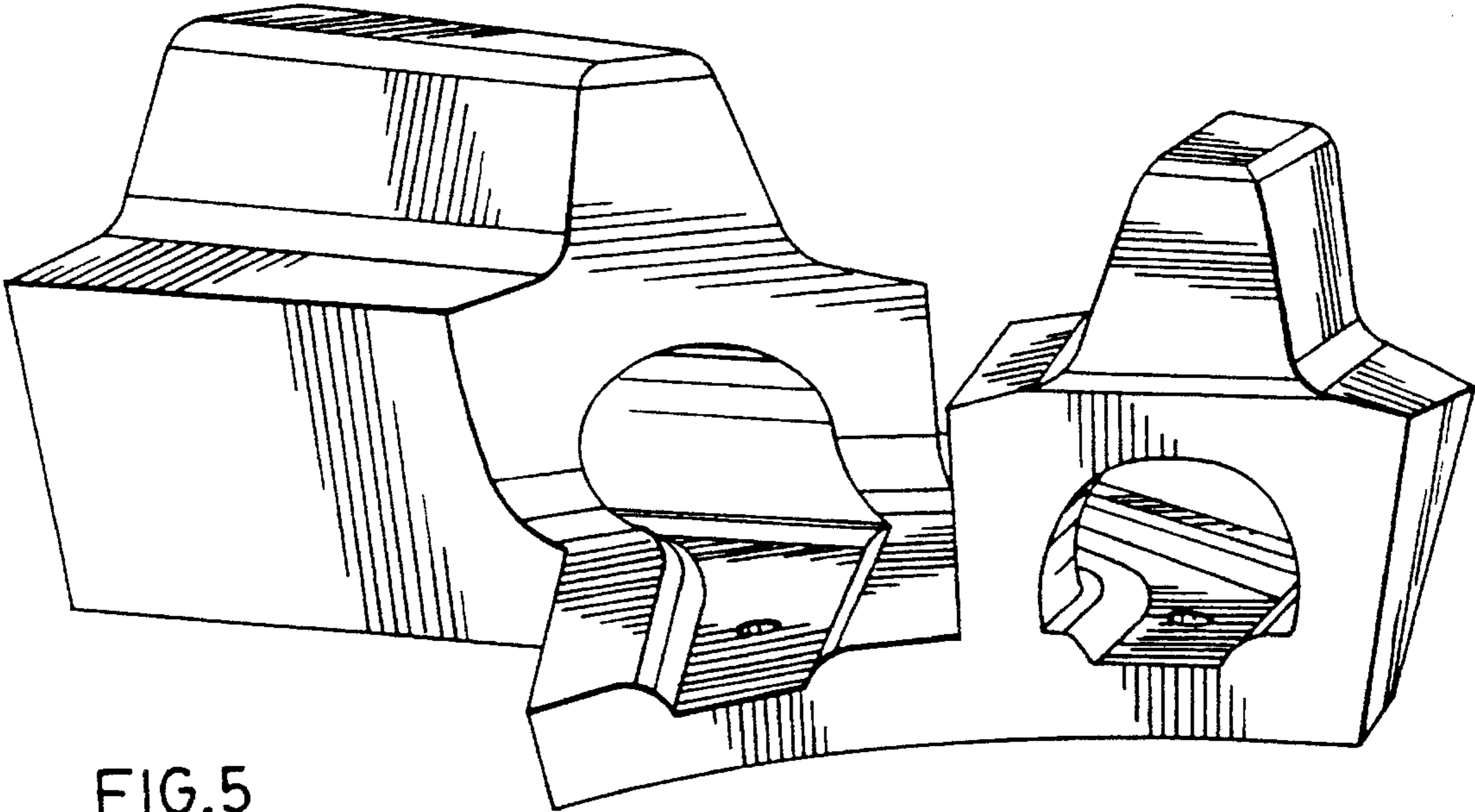

FIG. 5

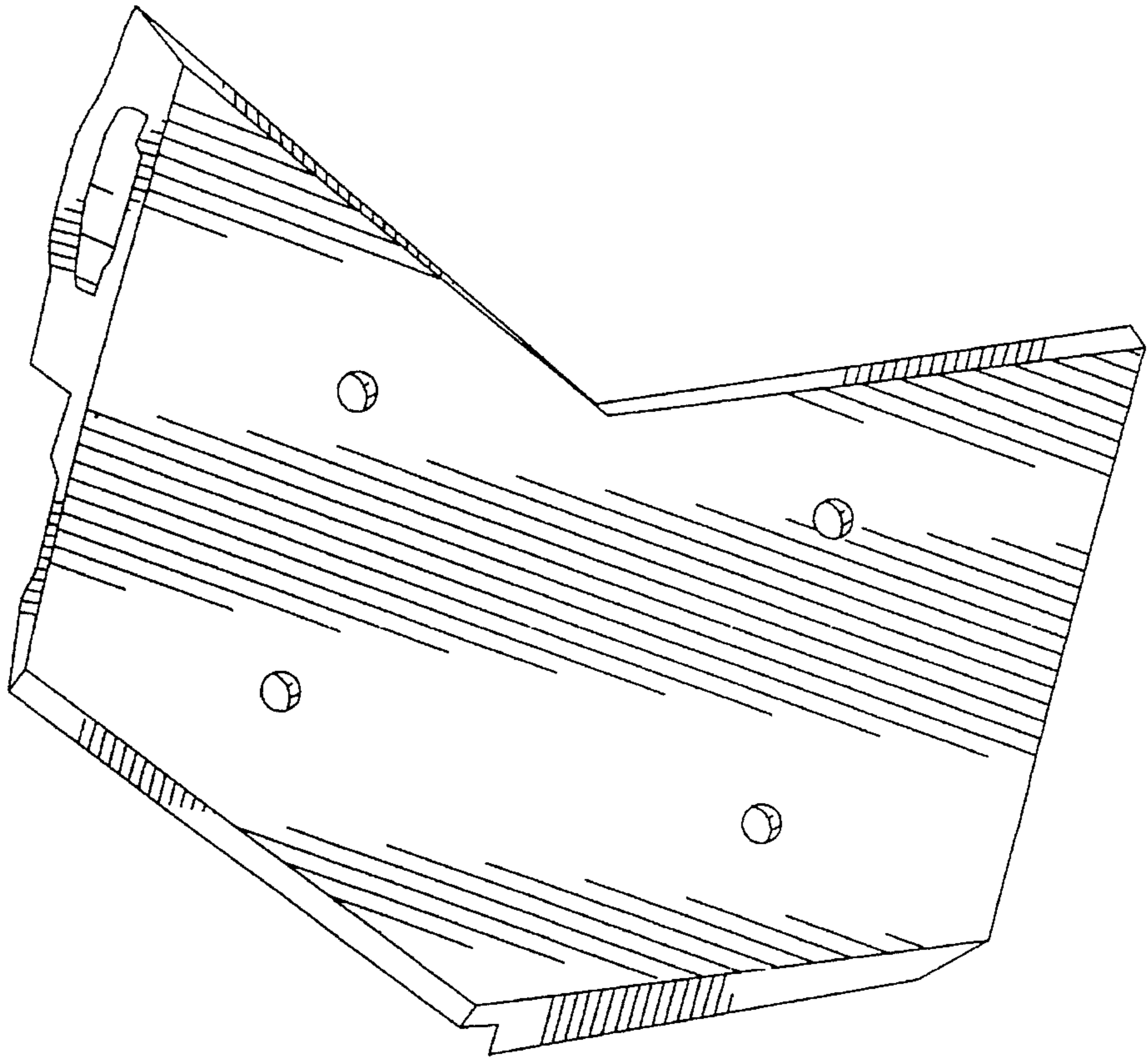

Fig. 7

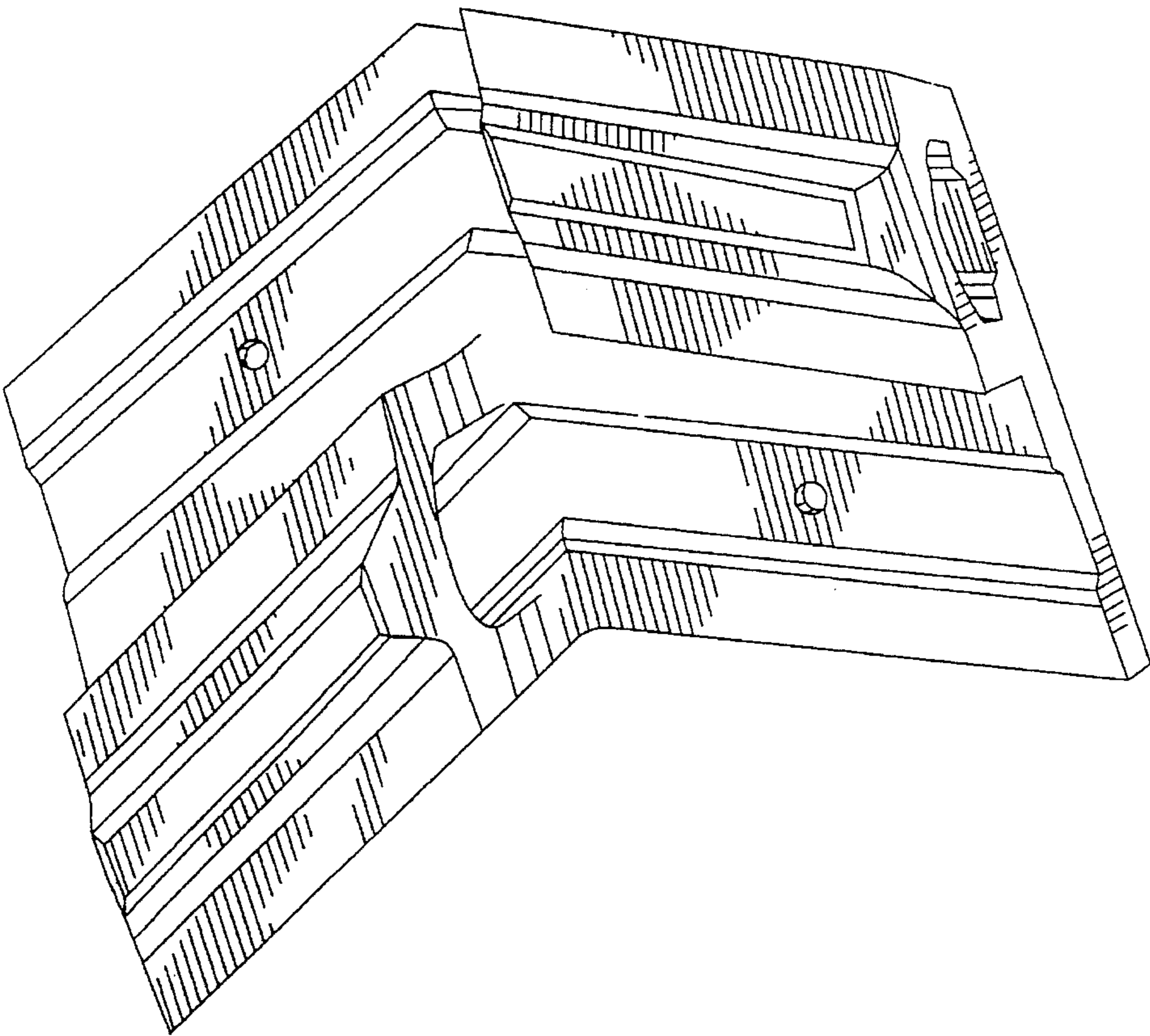

Fig. 6

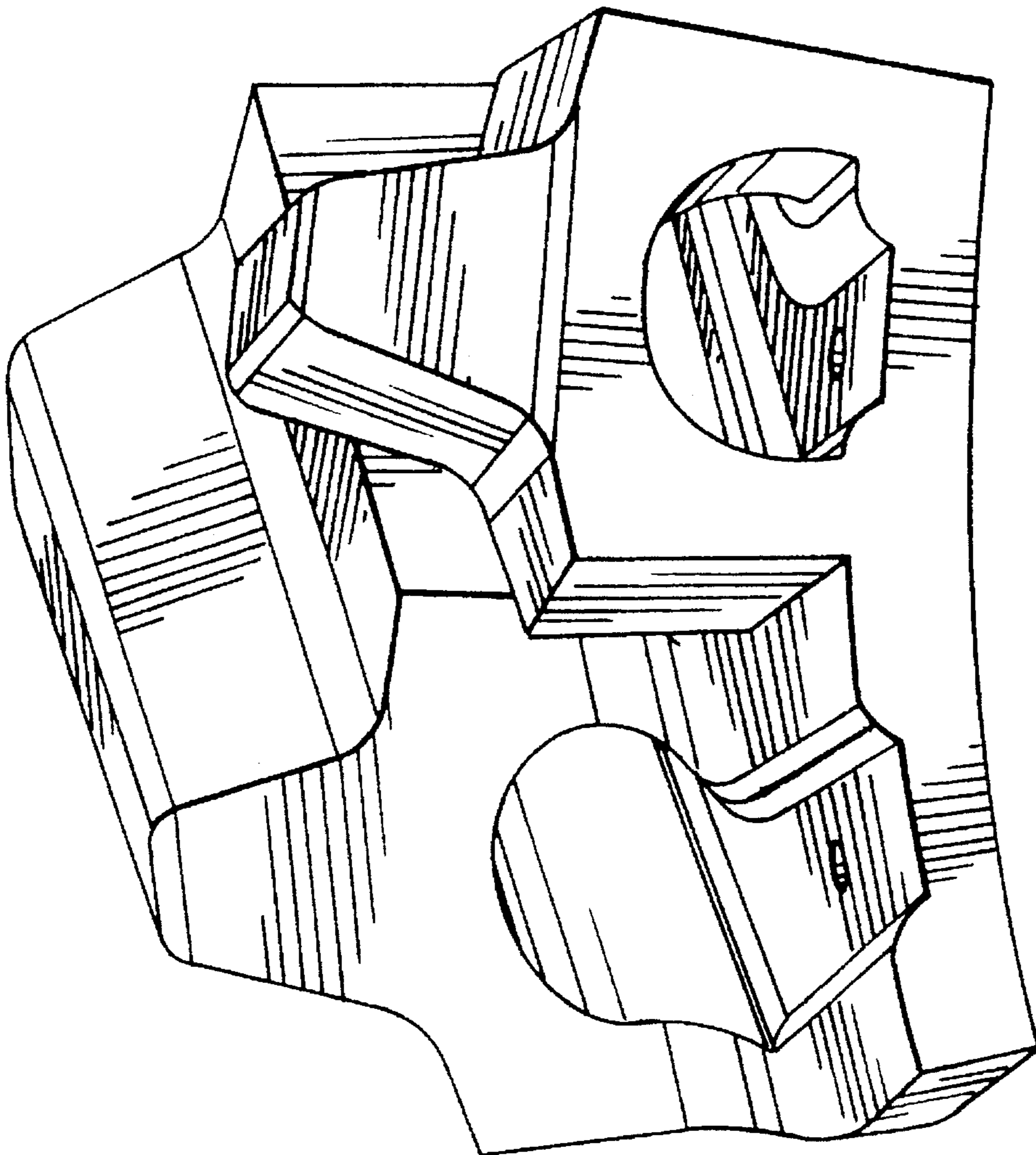

FIG. 8