



US00D371112S

United States Patent [19]

[11] Patent Number: **Des. 371,112**

Anthony

[45] Date of Patent: ****Jun. 25, 1996**

[54] **SHROUDED ELECTRICAL CONNECTOR**

[75] Inventor: **John C. Anthony**, Fairfield, Conn.

[73] Assignee: **Hubbell Incorporated**, Orange, Conn.

[**] Term: **14 Years**

[21] Appl. No.: **38,935**

[22] Filed: **May 17, 1995**

[52] U.S. Cl. **D13/146; D13/156**

[58] Field of Search **D13/146, 156; 439/134, 135, 324, 333, 337, 671, 673**

[56] **References Cited**

U.S. PATENT DOCUMENTS

D. 316,399	4/1991	Wharton	D13/156 X
1,818,290	8/1931	Wulle	200/50 B
1,924,691	8/1933	Lofgren	200/50 B
1,934,024	11/1933	Anderson	200/50 B
1,971,990	8/1934	Reynolds et al.	200/50 B
2,241,828	5/1941	Reynolds	200/50 B
3,008,116	11/1961	Blanchenet	439/680 X
3,551,880	12/1970	Hartwell	439/465
3,585,323	7/1971	Appleton et al.	200/50 B
3,784,961	1/1974	Garland, Jr.	439/465
4,241,969	12/1980	D'Amato et al.	439/333 X
4,245,875	1/1981	Shaffer et al.	339/32 R
4,503,293	3/1985	Knecht	200/50 B
4,553,000	11/1985	Appleton	200/50 B
4,604,505	8/1986	Henninger	200/50 B
4,736,999	4/1988	Marks et al.	439/680 X
4,801,277	1/1989	Seilhan	439/680
5,046,961	9/1991	Hoffman	439/141
5,273,445	12/1993	Ehrenfels et al.	439/134
5,346,406	9/1994	Hoffman et al.	439/474

OTHER PUBLICATIONS

GE Wiring Devices—Full Line Catalog—1989—pp. C4, C5, C12, C13, C15, D3 and D4.

Killark Catalog, Electrical Construction Products, 1994, Section 1, p. 1 and Section 4, pp. 1-16.

Hubbell Catalog, Wiring Device & Systems, Kellems Wire Management Marine Wiring Products, 1995, Section A, pp. A19-A46, Section B, pp. B1-B54, Section E, pp. E1-E14, Section F, pp. F1-F24 and Section M, pp. M1-M25.

Primary Examiner—Joel Sincavage

Attorney, Agent, or Firm—Jerry M. Presson; David L. Tarnoff

[57] **CLAIM**

The ornamental design for a shrouded electrical connector, as shown and described.

DESCRIPTION

FIG. 1 is a perspective view of the shrouded electrical connector according to a first embodiment of my new design;

FIG. 2 is a front side elevational view of the shrouded electrical connector of my new design shown in FIG. 1;

FIG. 3 is a rear side elevational view of the shrouded electrical connector of my new design shown in FIGS. 1 and 2;

FIG. 4 is a top plan view of the shrouded electrical connector of my new design shown in FIGS. 1-3;

FIG. 5 is a bottom plan view of the shrouded electrical connector of my new design shown in FIGS. 1-4;

FIG. 6 is a left end elevational view of the shrouded electrical connector of my new design shown in FIGS. 1-5;

FIG. 7 is a right end elevational view of the shrouded electrical connector of my new design shown in FIGS. 1-6;

FIG. 8 is a perspective view of a shrouded electrical connector according to a second embodiment of my new design with the closure cap covering the contacts;

FIG. 9 is a perspective view of the shrouded electrical connector of my new design shown in FIG. 8, with the closure cap exposing the contacts;

FIG. 10 is a front side elevational view of the shrouded electrical connector of my new design shown in FIGS. 8 and 9, with the closure cap covering the contacts;

FIG. 11 is a front side elevational view of the shrouded electrical connector of my new design shown in FIGS. 8-10, with the closure cap exposing the contacts;

FIG. 12 is a rear side elevational view of the shrouded electrical connector of my new design shown in FIGS. 8-11, with the closure cap covering the contacts;

FIG. 13 is a rear side elevational view of the shrouded electrical connector and closure cap of my new design shown in FIGS. 8-12, with the closure cap exposing the contacts;

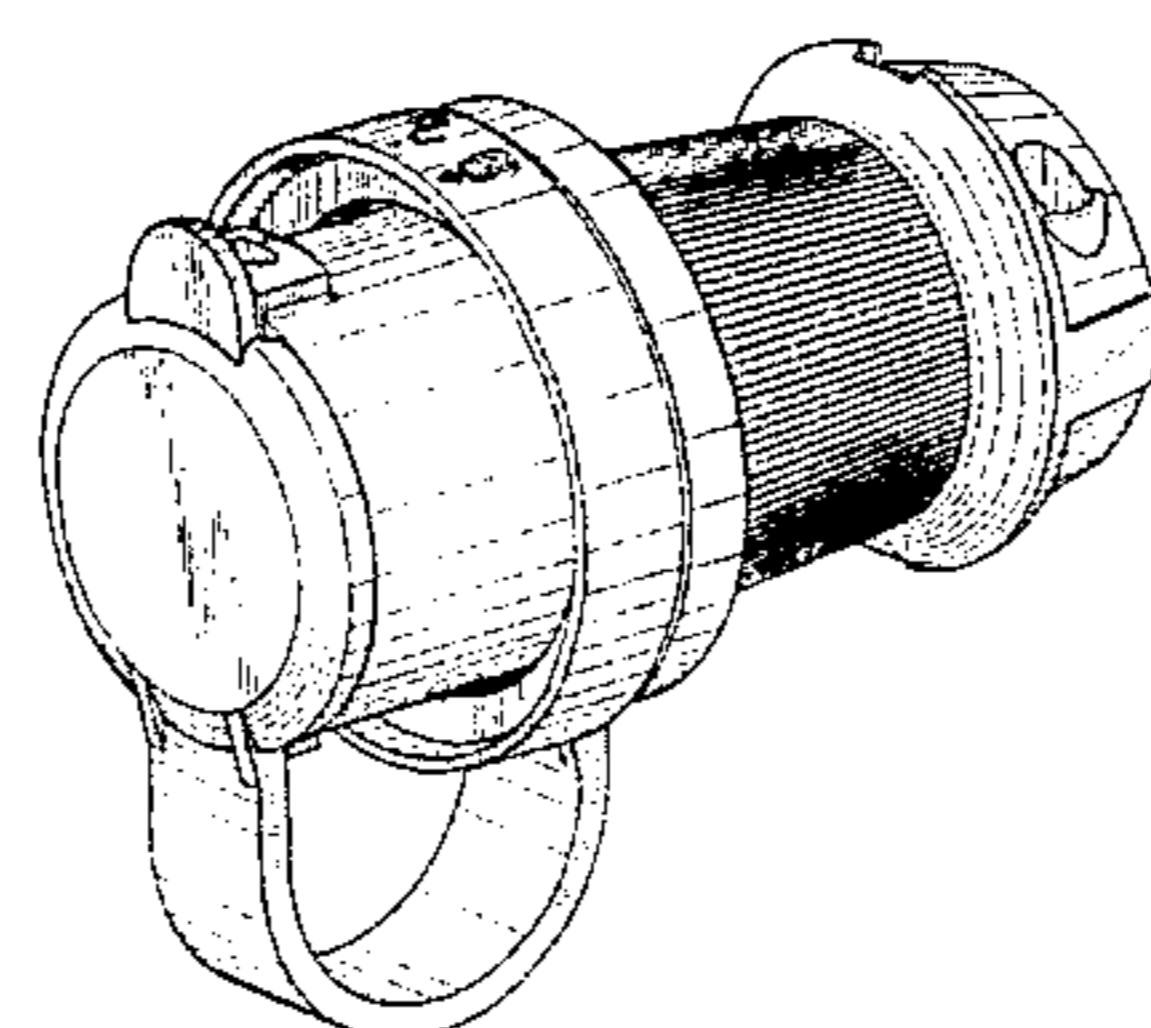
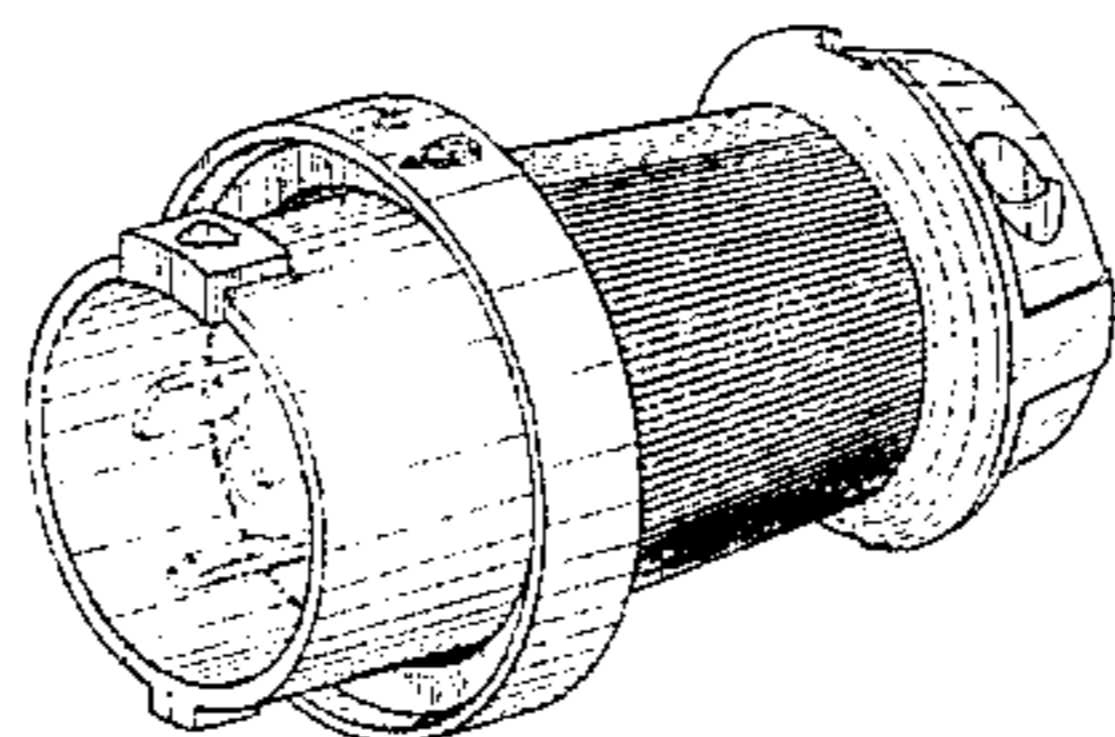

FIG. 14 is a top plan view of the shrouded electrical connector of my new design shown in FIGS. 8-13, with the closure cap covering the contacts;

FIG. 15 is a top plan view of the shrouded electrical connector of my new design shown in FIGS. 8-14, with the closure cap exposing the contacts;

FIG. 16 is a bottom plan view of the shrouded electrical connector of my new design shown in FIGS. 8-15 with the closure cap covering the contacts;

FIG. 17 is a bottom plan view of the shrouded electrical connector of my new design shown in FIGS. 8-16, with the closure cap exposing the contacts;

FIG. 18 is a left end elevational view of the shrouded electrical connector of my new design shown in FIGS. 8-17 with the closure cap covering the contacts;

FIG. 19 is a left end elevational view of the shrouded electrical connector of my new design shown in FIGS. 8-18, with the closure cap exposing the contacts;

FIG. 20 is a right end elevational view of the shrouded electrical connector of my new design shown in FIGS. 8-19, with the closure cap covering the contacts; and,

FIG. 21 is a right end elevational view of the shrouded electrical connector of my new design shown in FIGS. 8-20, with the closure cap exposing the contacts.

The broken line showing of environment in the figures is for illustrative purposes only and forms no part of the claimed design. The electrical connector of the claimed design can be either a male or female electrical connector.

1 Claim, 13 Drawing Sheets

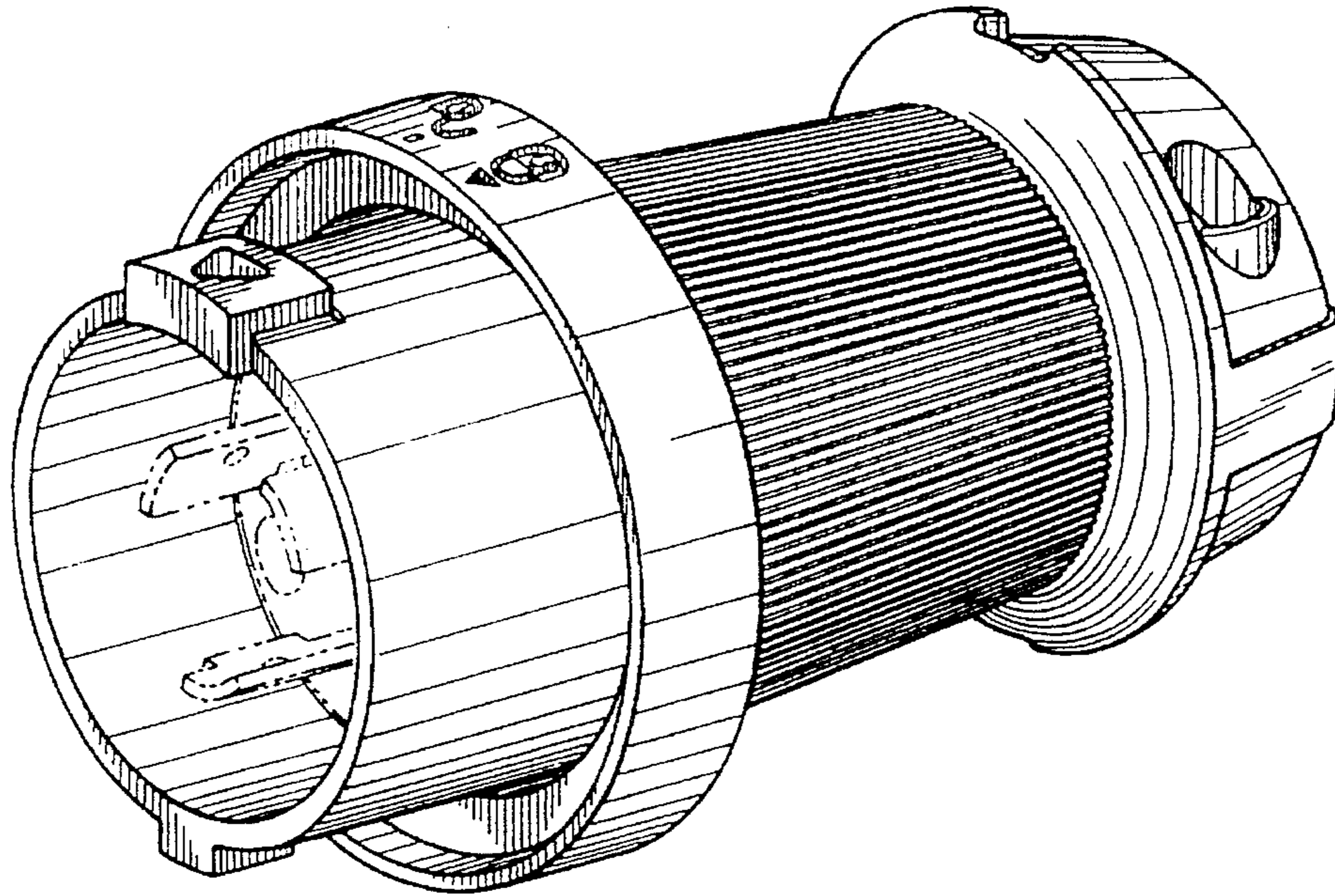

FIG. 1

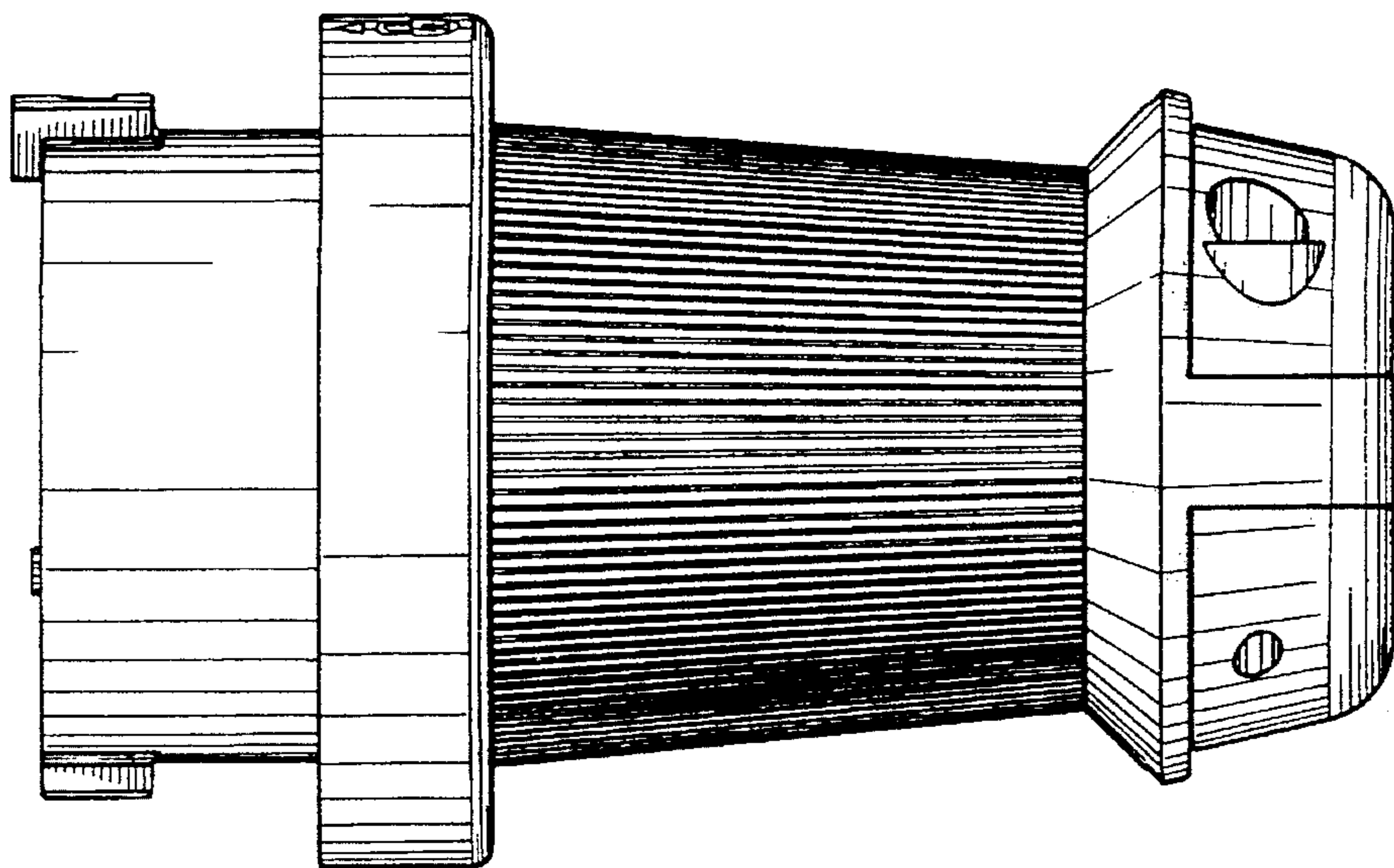

FIG. 2

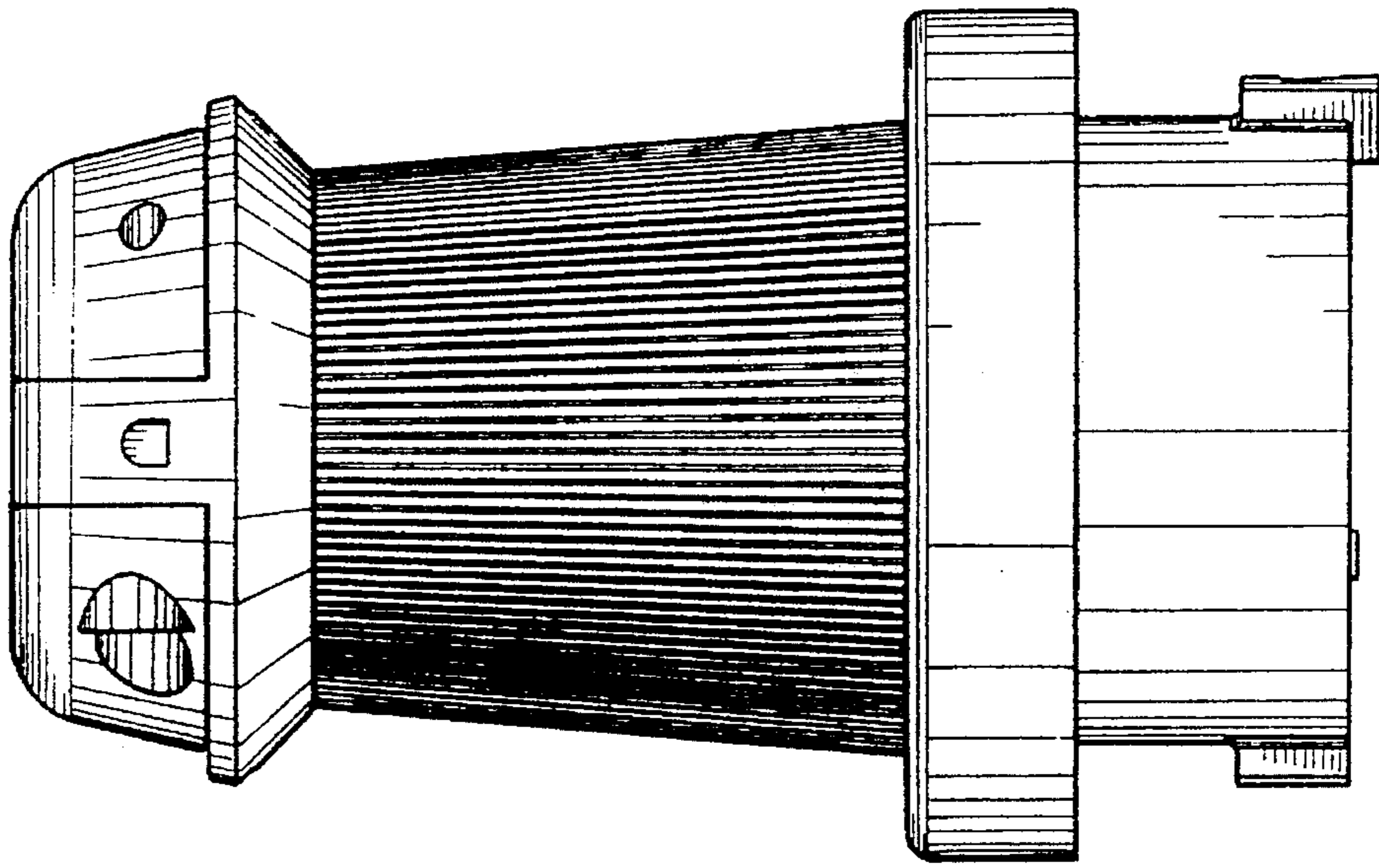

FIG. 3

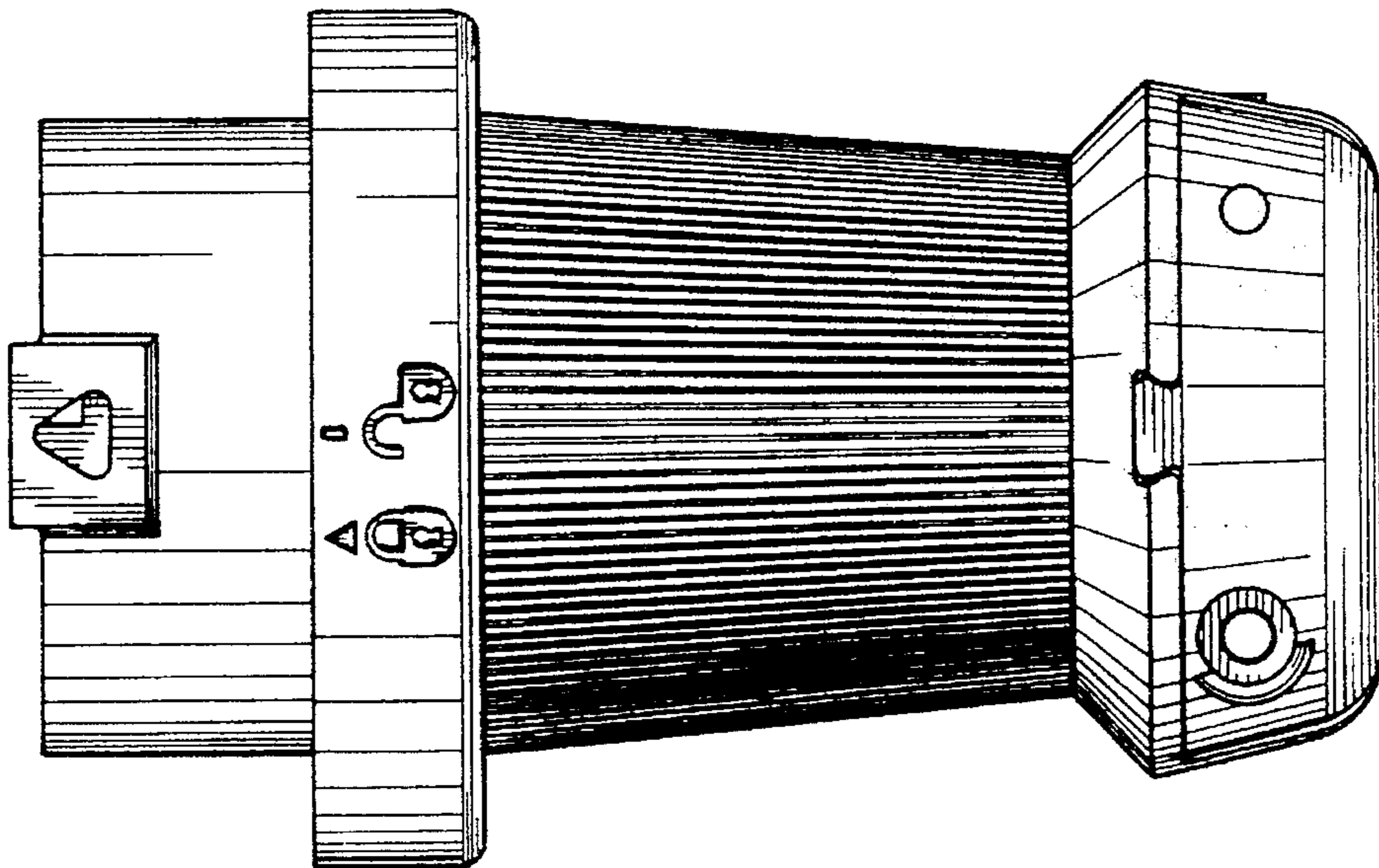

FIG. 4

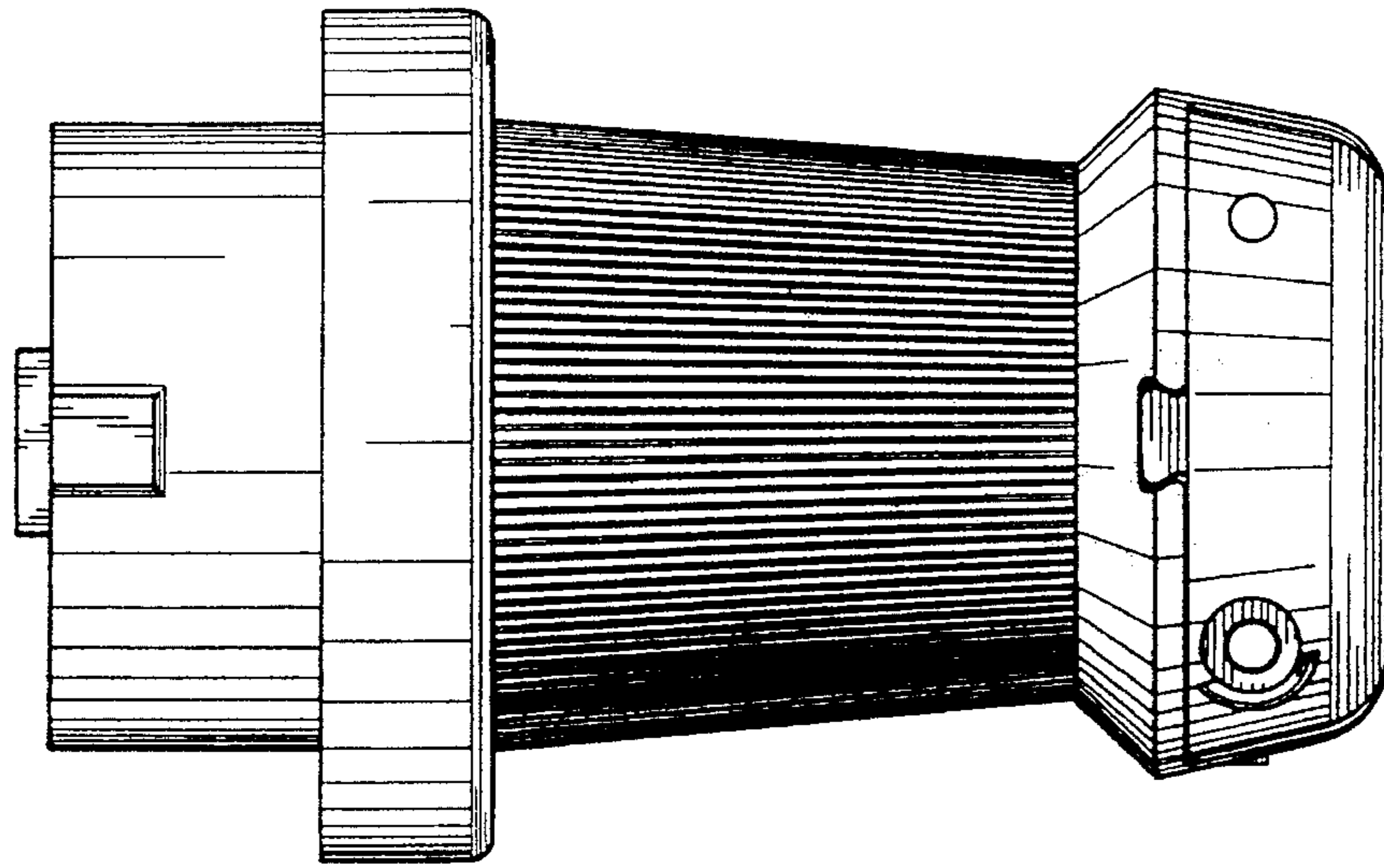

FIG. 5

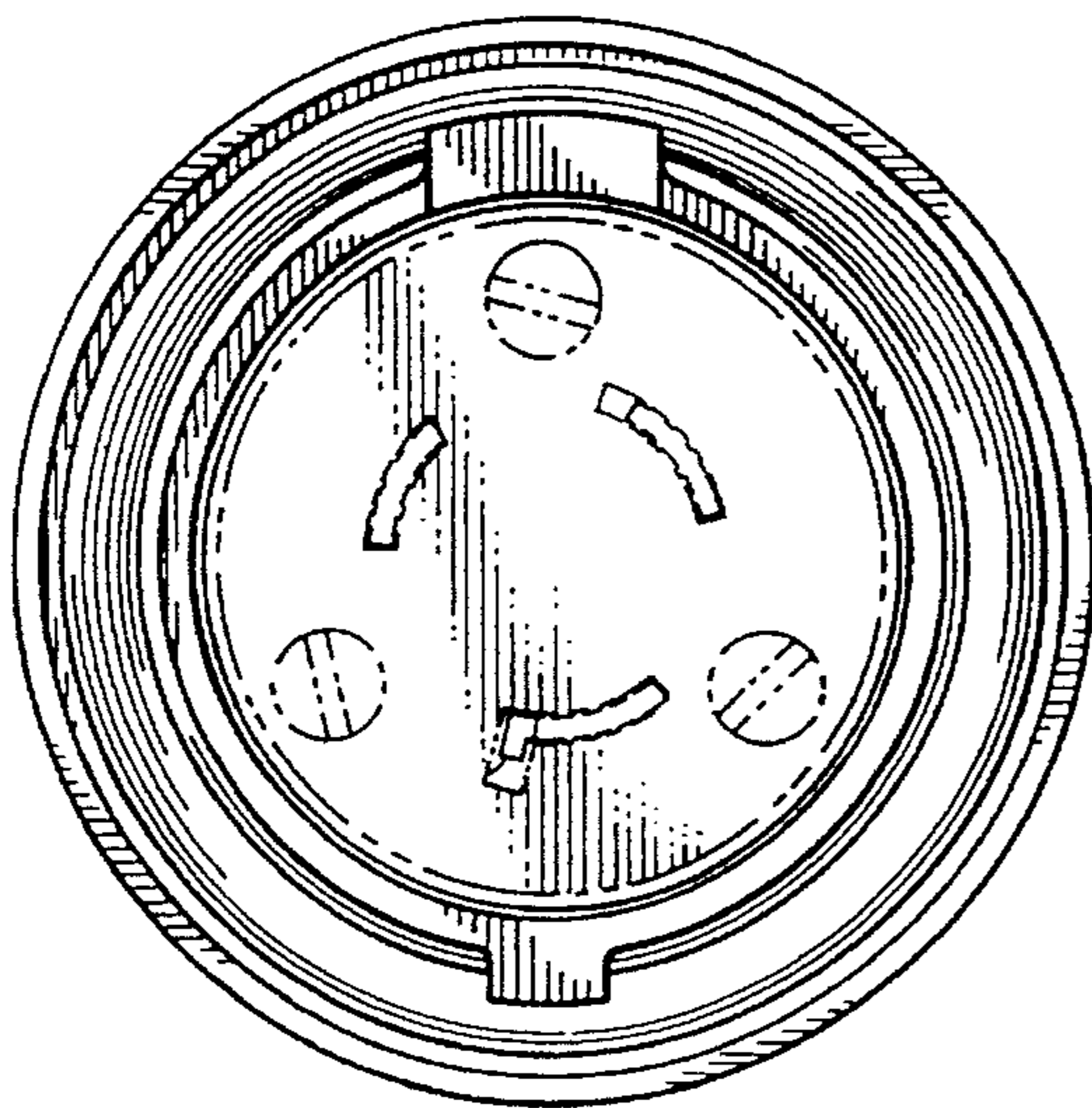

FIG. 6

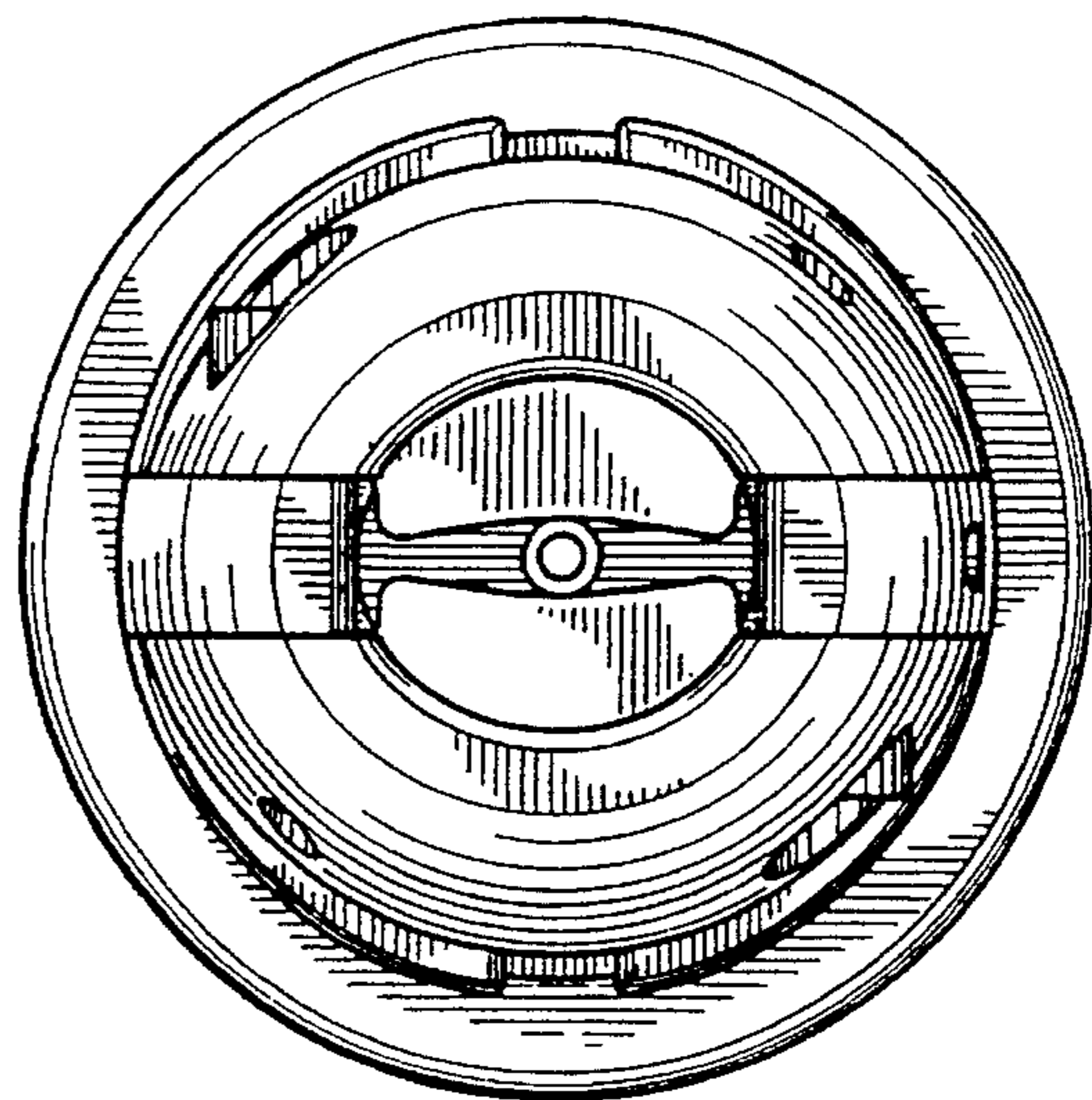

FIG. 7

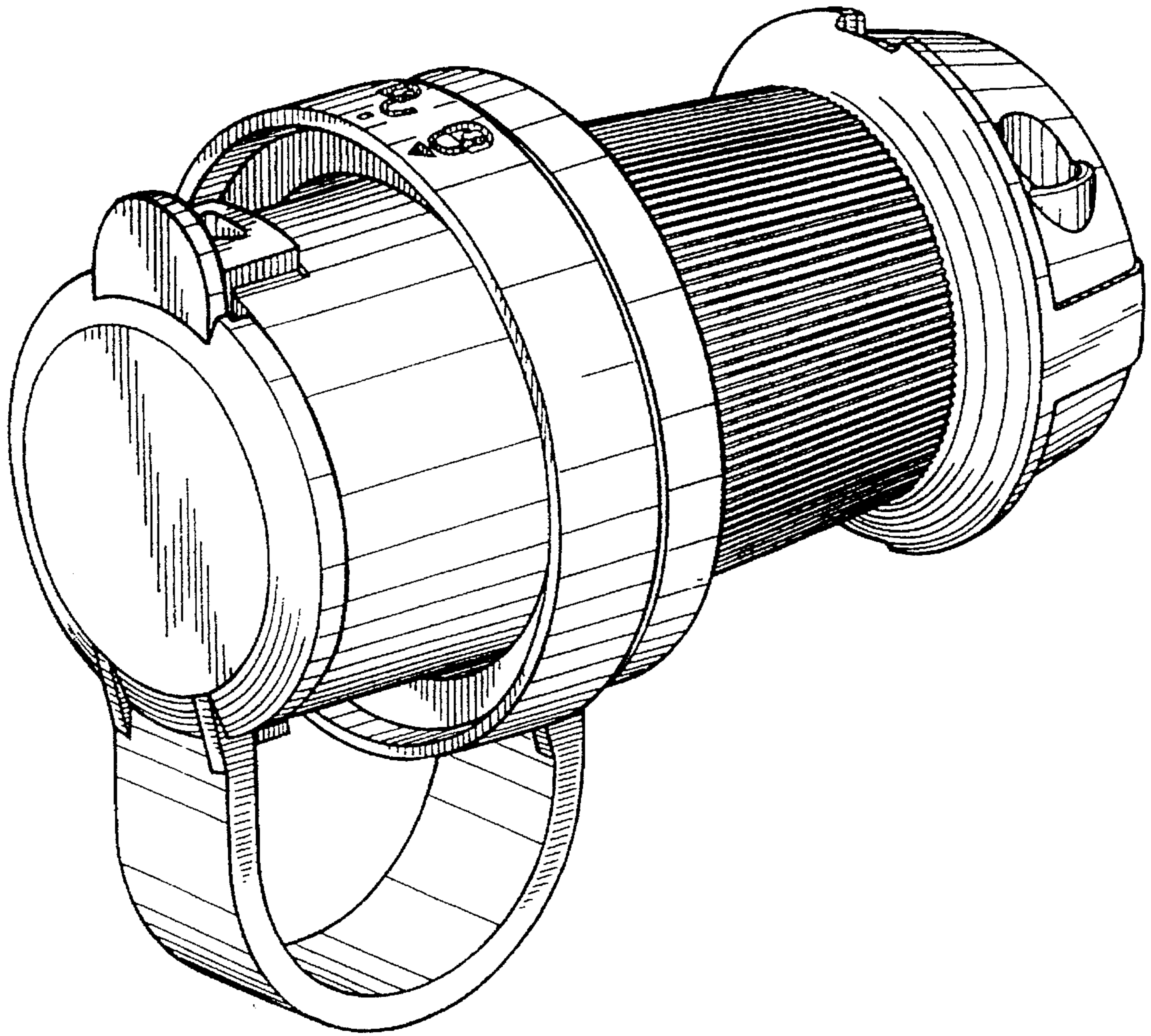

FIG. 8

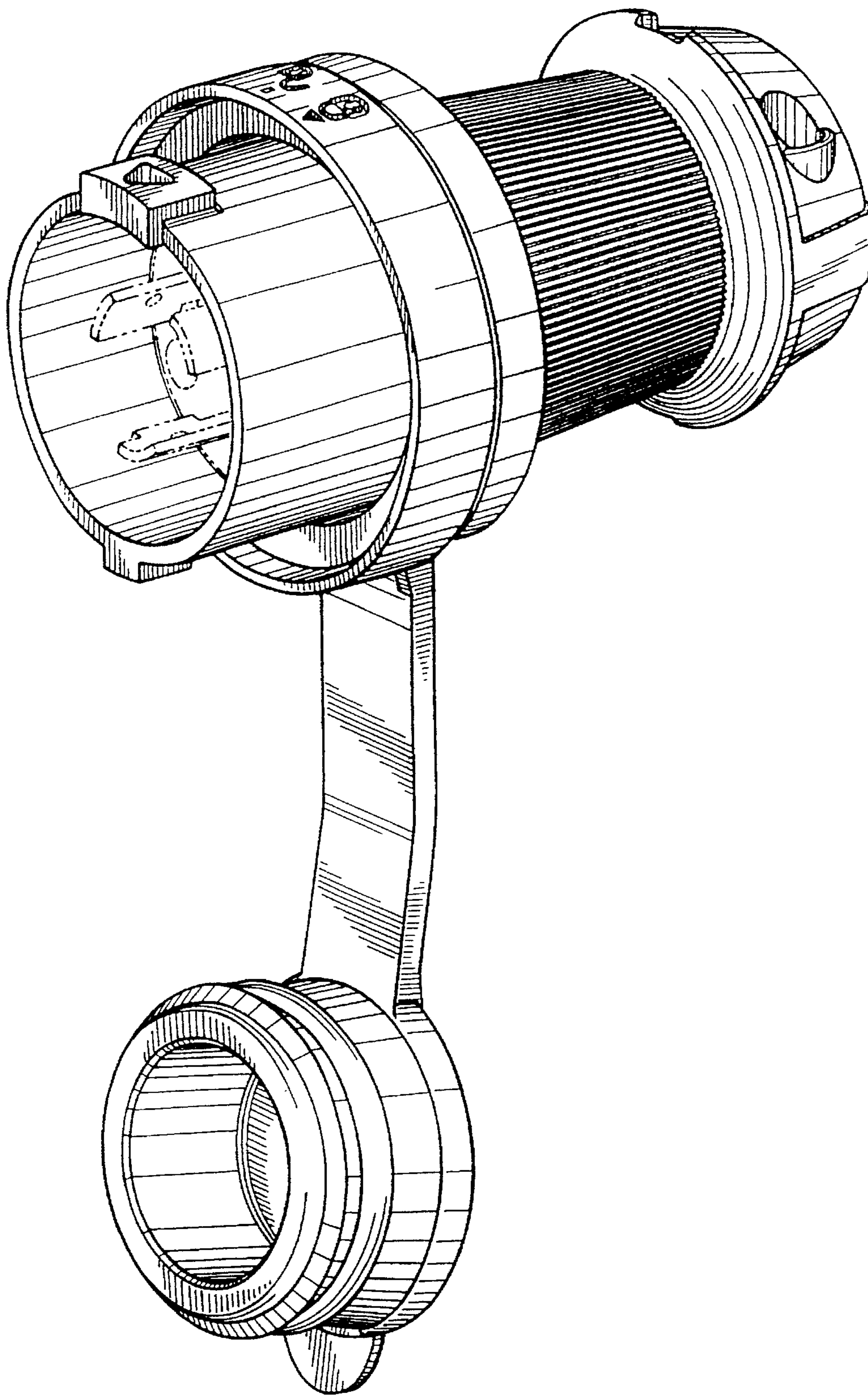

FIG. 9

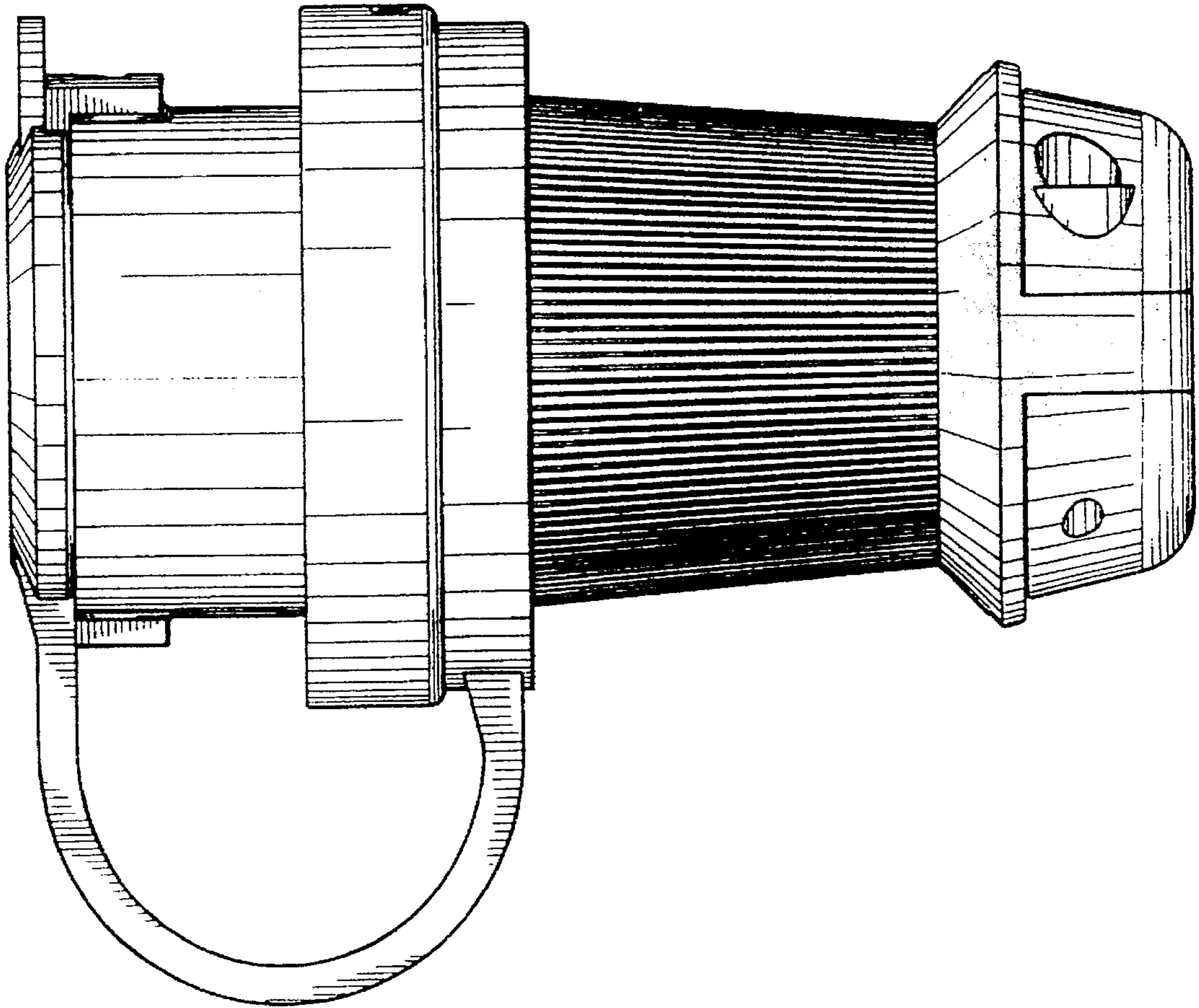

FIG. 10

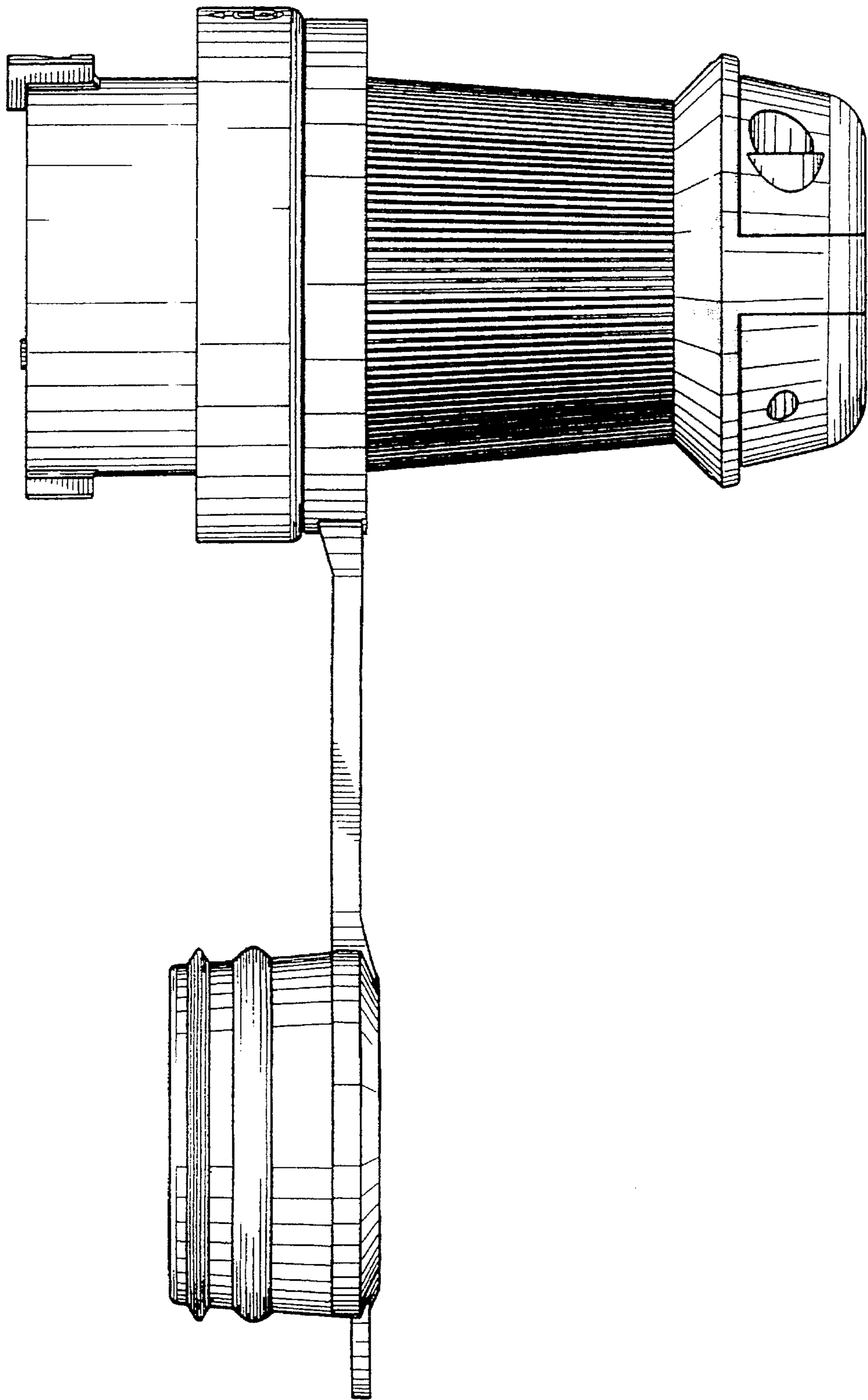

FIG. II

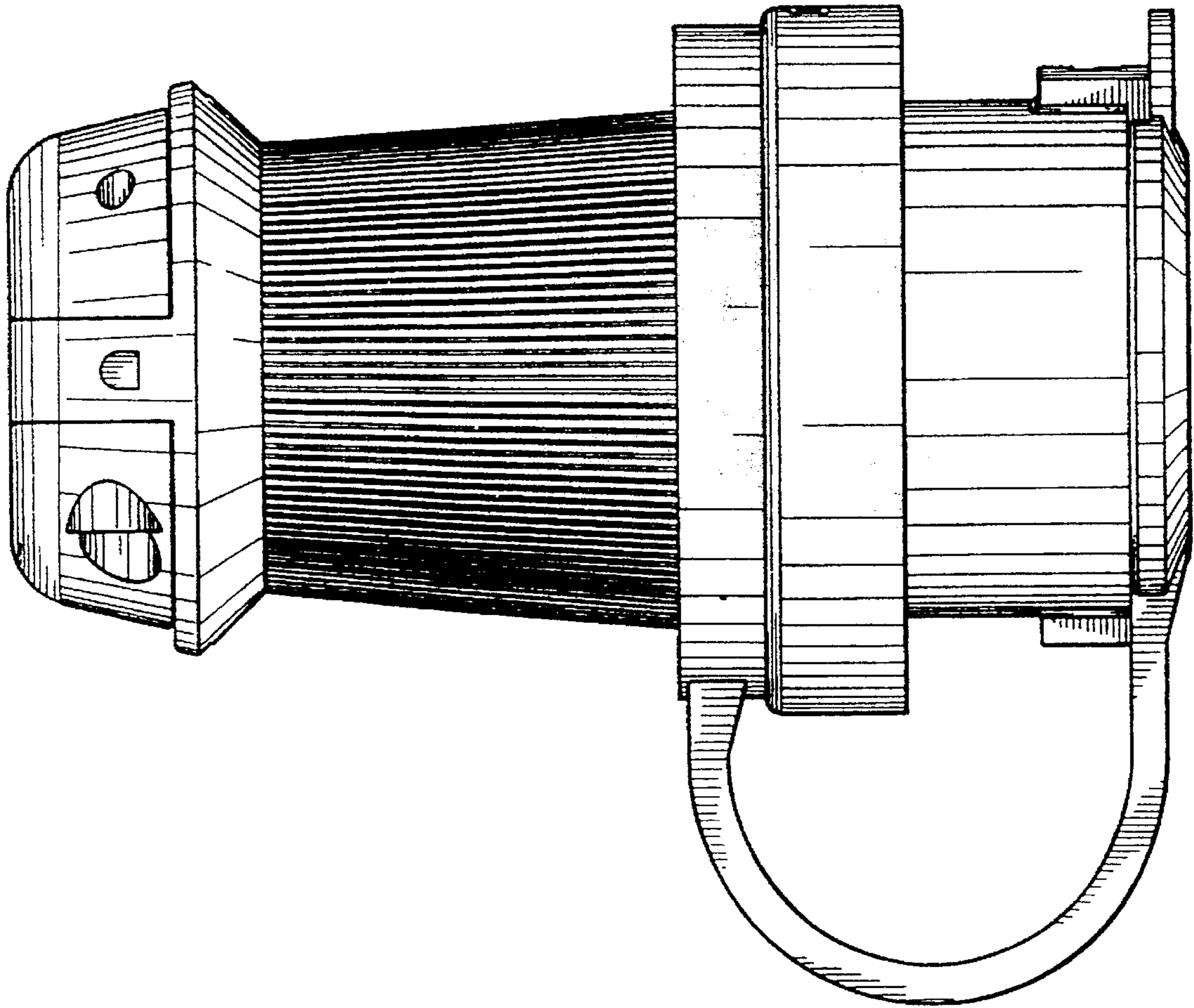

FIG. 12

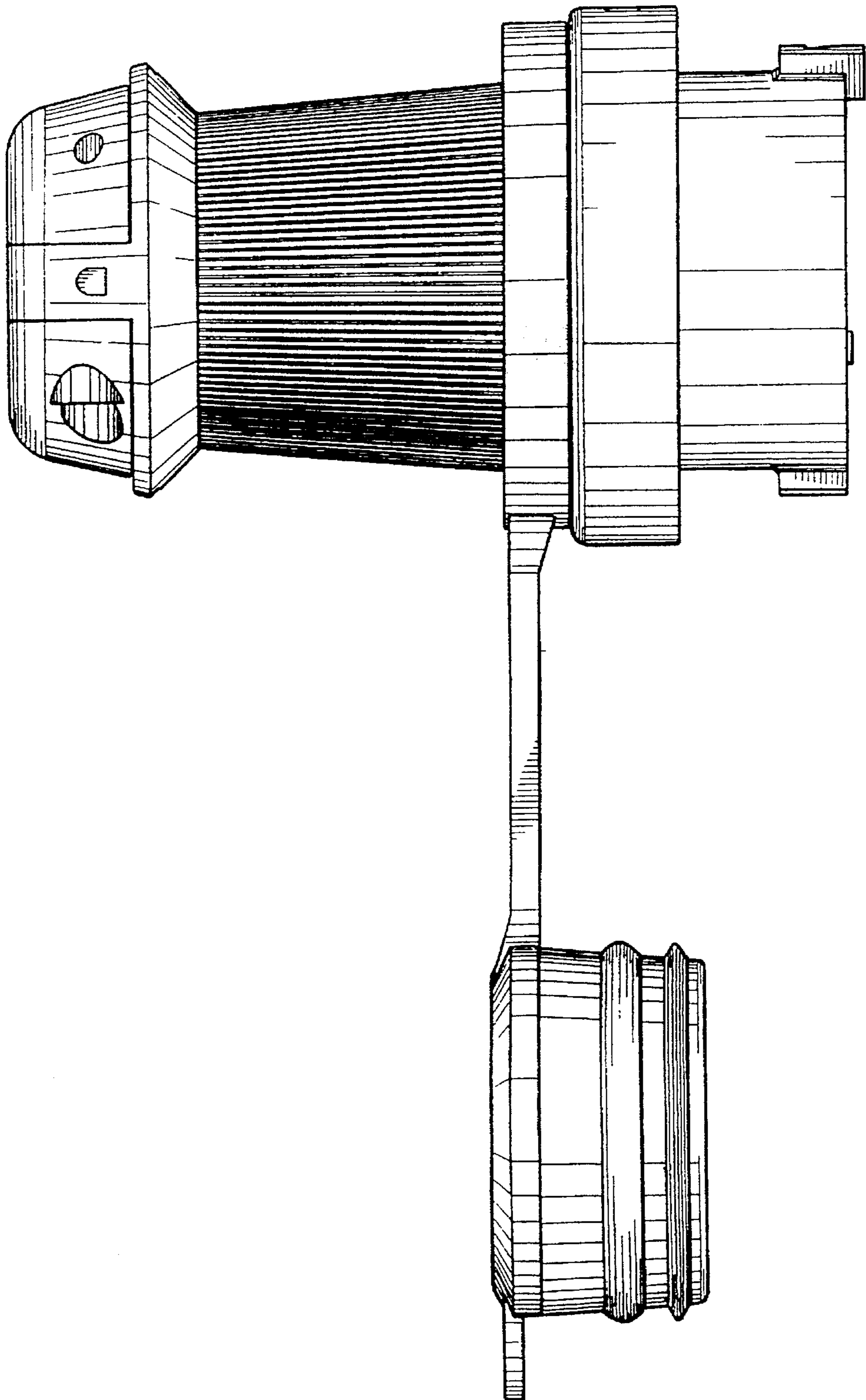

FIG. 13

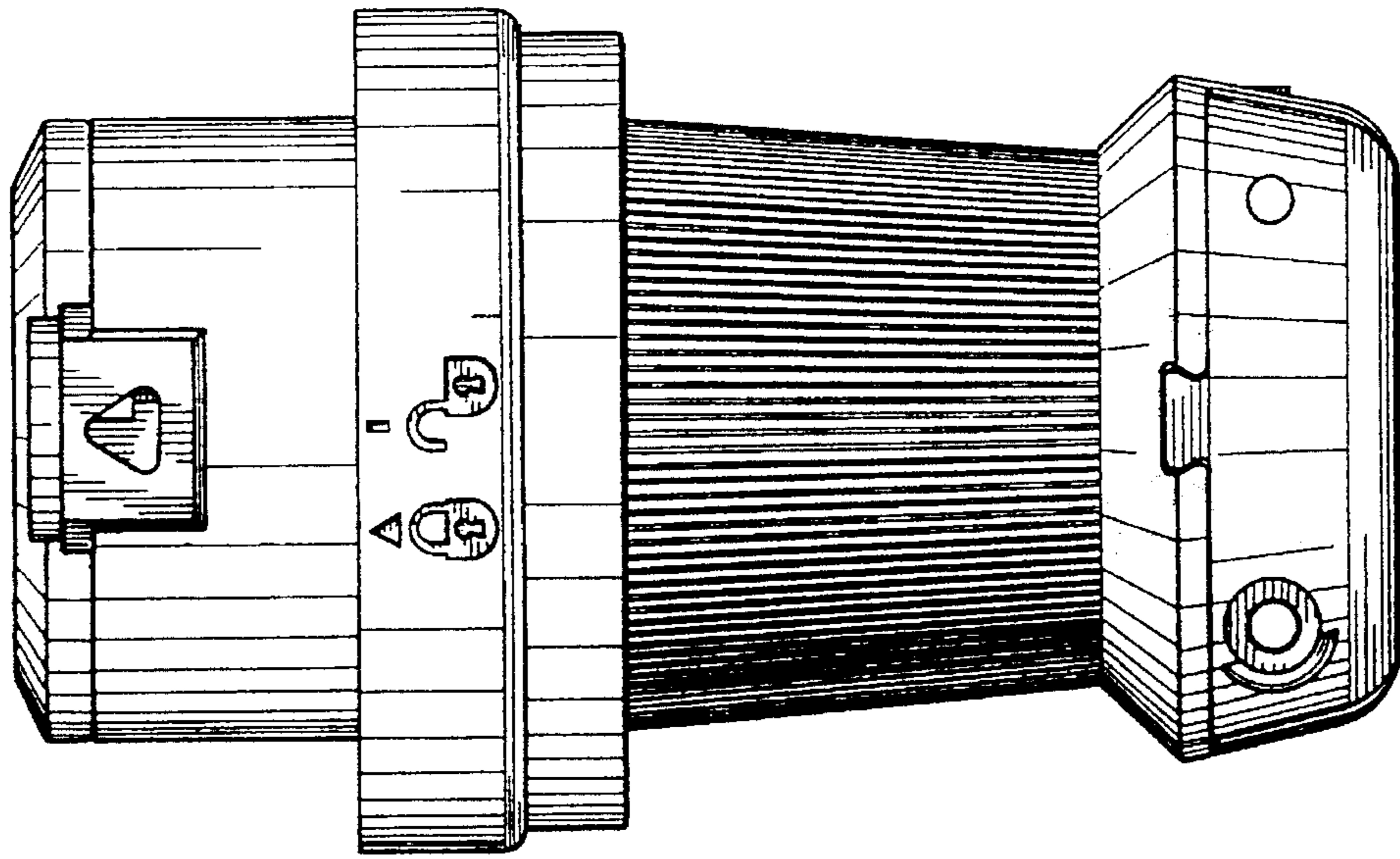

FIG. 14

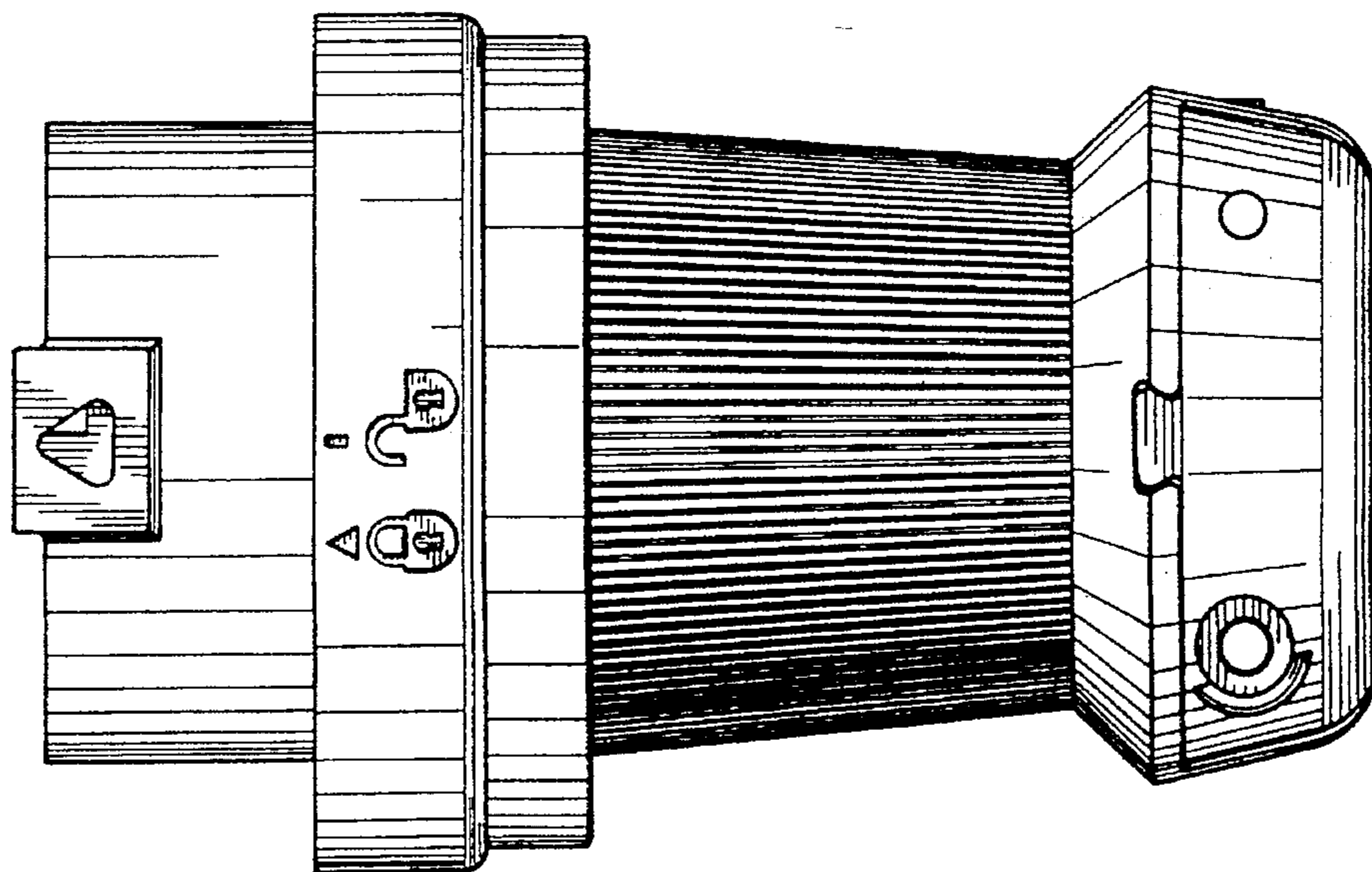

FIG. 15

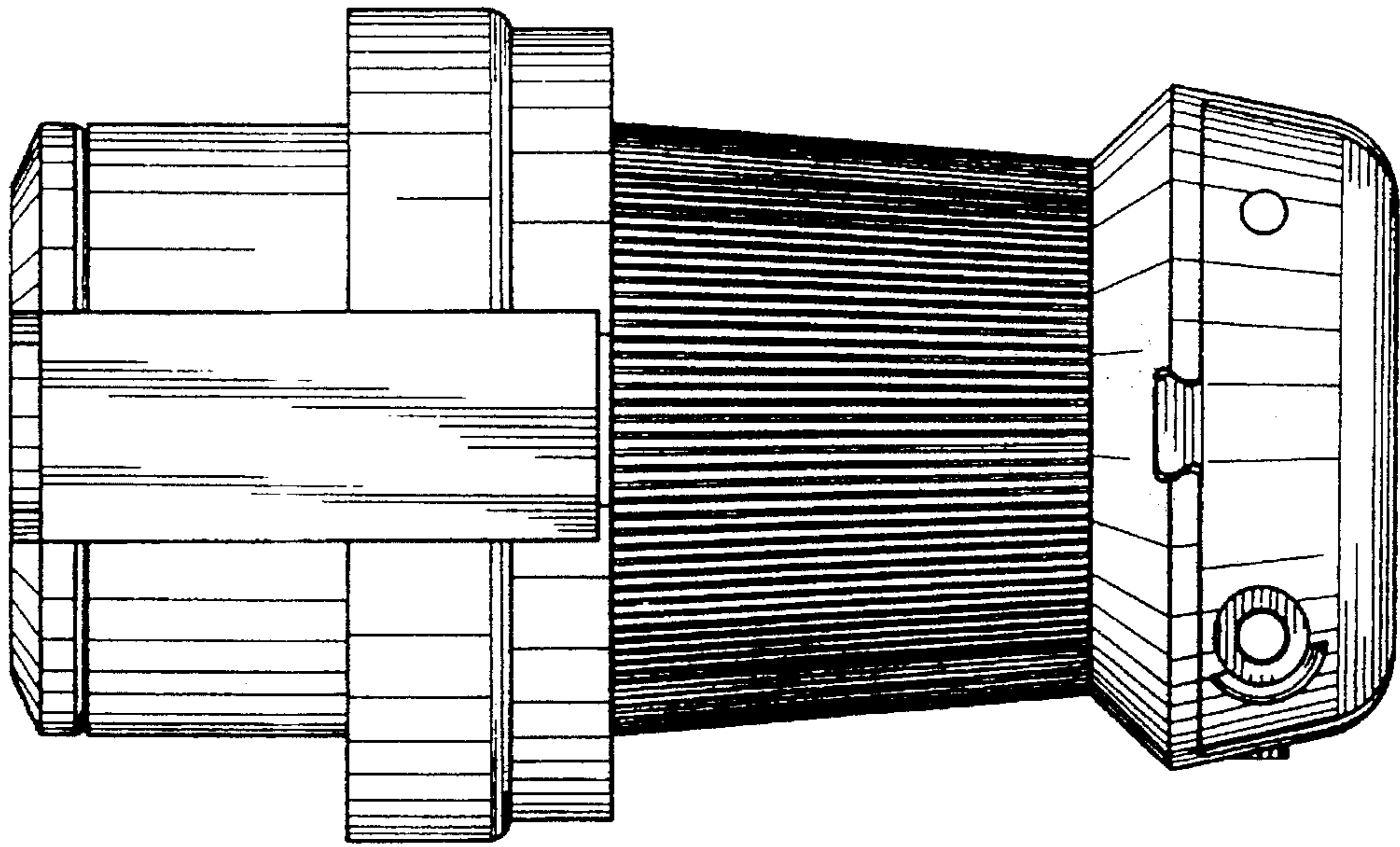

FIG. 16

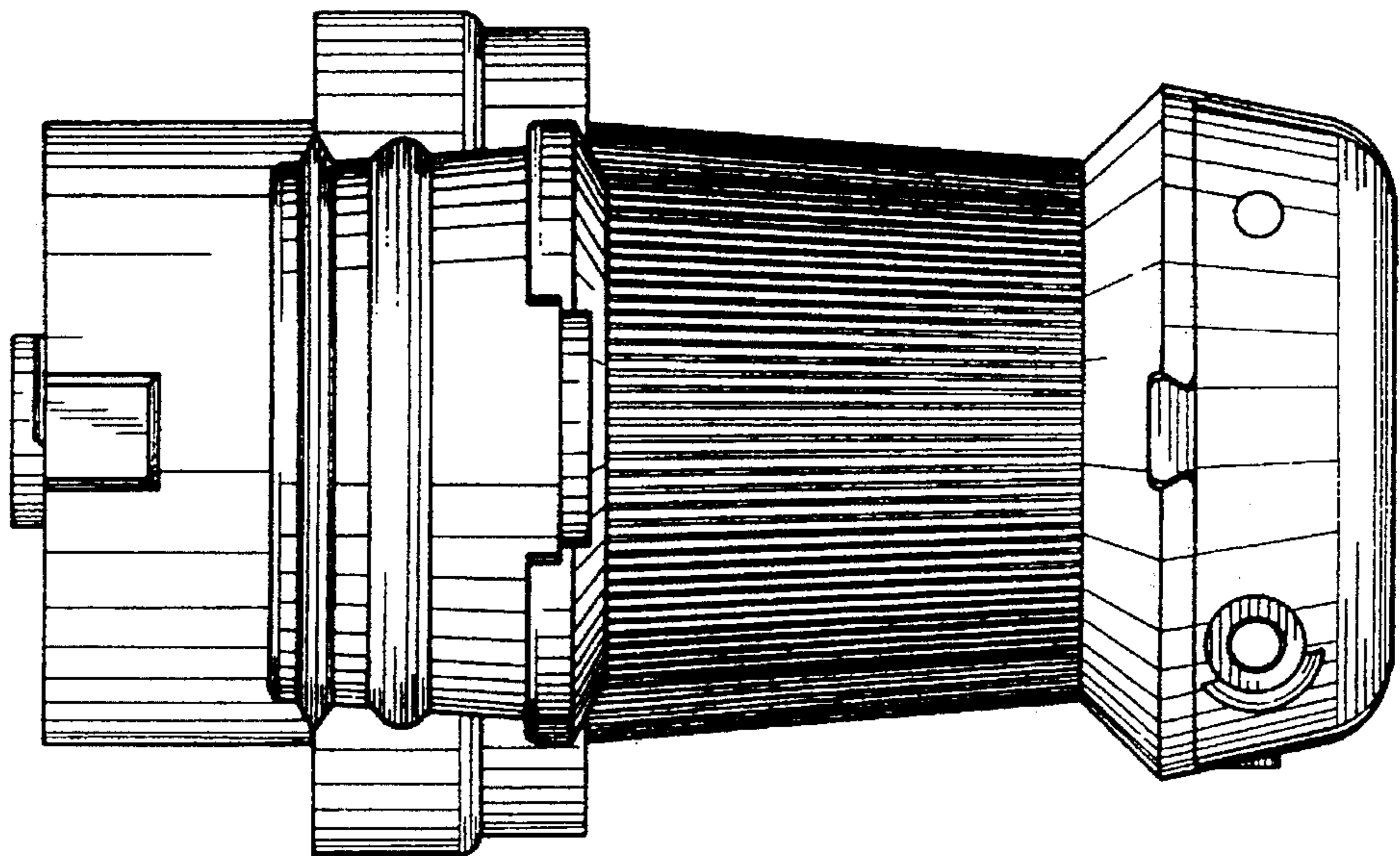

FIG. 17

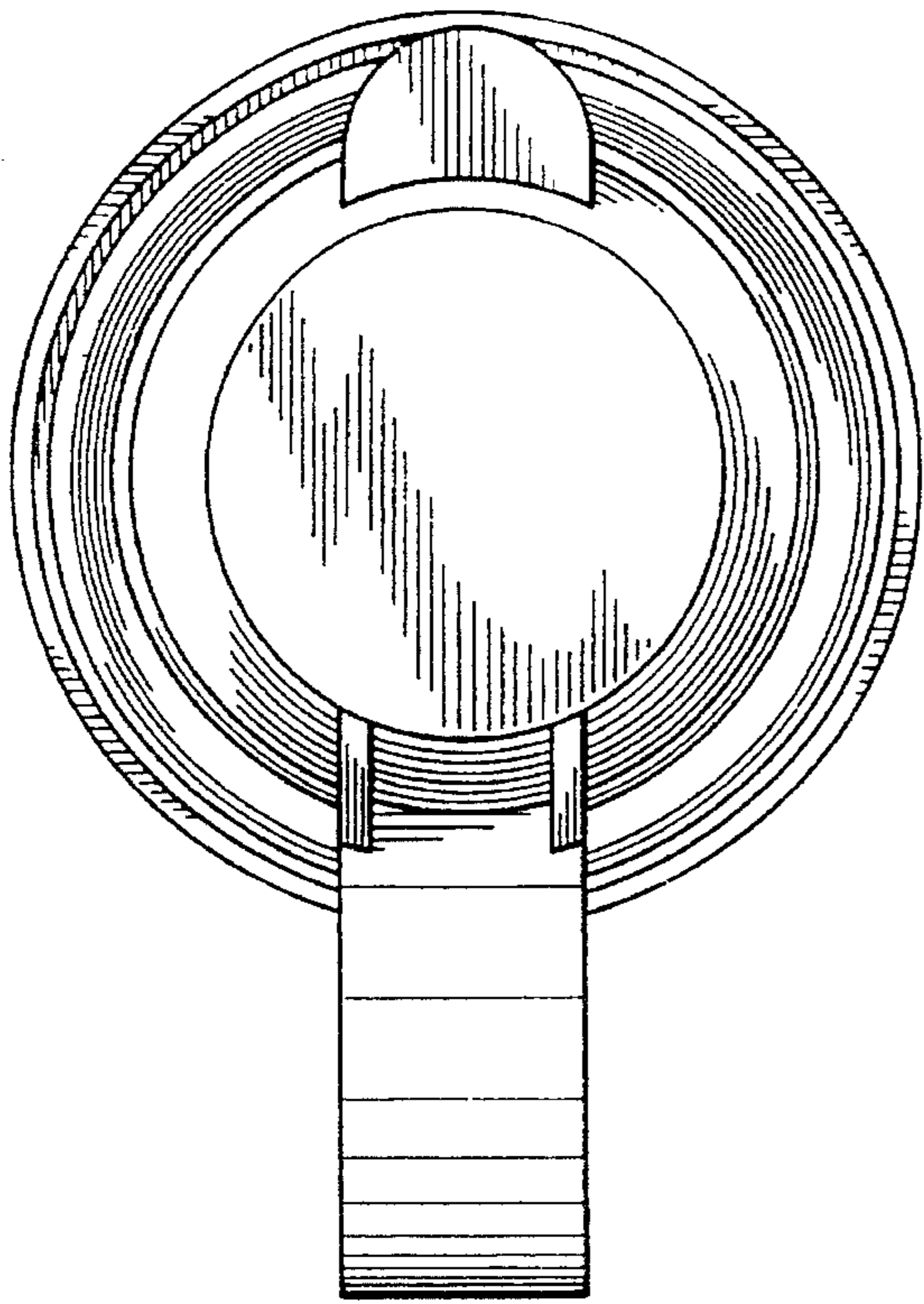

FIG. 18

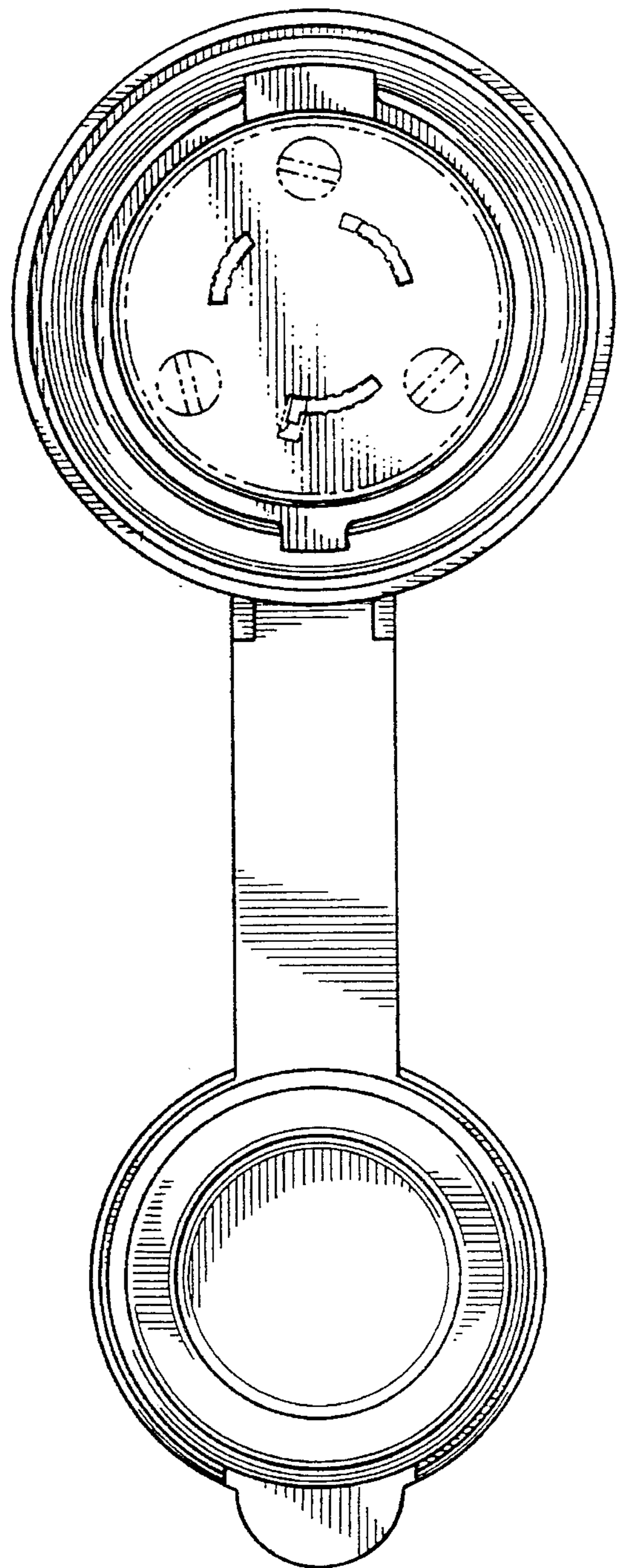

FIG. 19

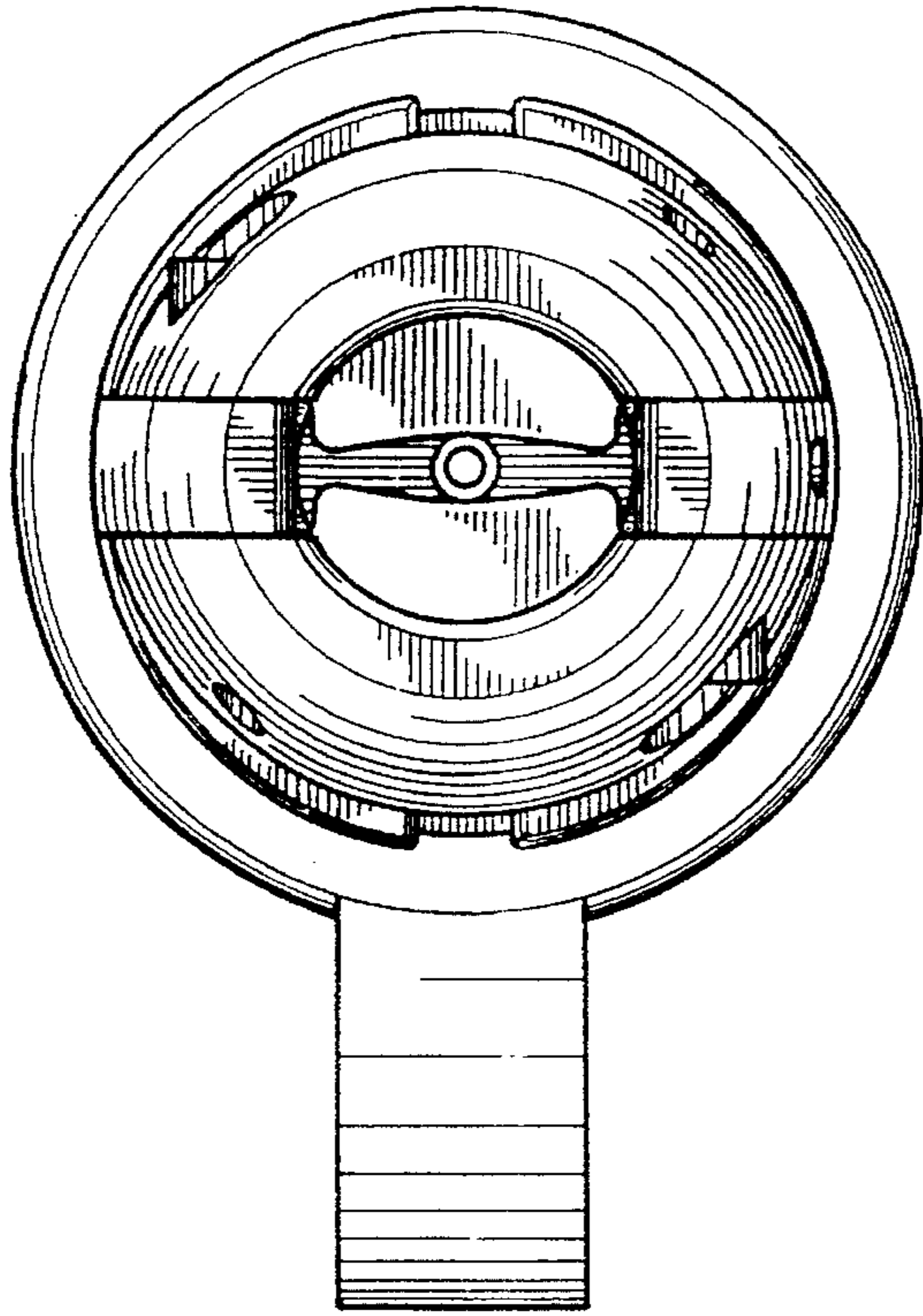

FIG. 20

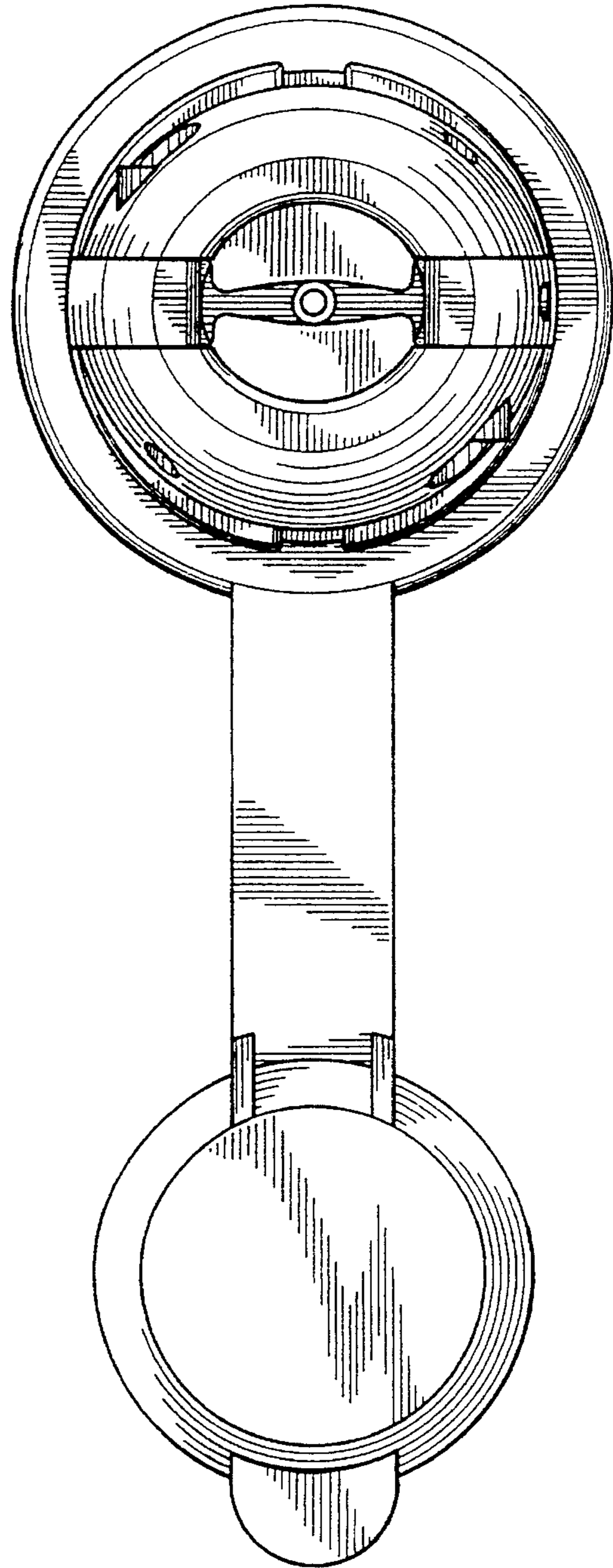

FIG. 21