



US00D371105S

# United States Patent [19]

Graham et al.

[11] Patent Number: **Des. 371,105**

[45] Date of Patent: **\*\*Jun. 25, 1996**

[54] **AIRCRAFT**

[75] Inventors: **Arthur D. B. Graham**, Western Australia, Australia; **John G. Roncz**, Granger, Ind.; **Graham Swannell**, Western Australia, Australia

[73] Assignee: **Composite Technology PTY Ltd.**, Australia

[\*\*] Term: **14 Years**

[21] Appl. No.: **7,481**

[22] Filed: **Apr. 23, 1993**

[30] **Foreign Application Priority Data**

Oct. 23, 1992 [AU] Australia ..... 2945/92  
[52] U.S. Cl. .... **D12/331**; D12/319; D12/344  
[58] Field of Search ..... D12/319, 344,  
D12/337, 335, 338; 244/45 R, 45 A, 29,  
13, 16

[56] **References Cited**

**U.S. PATENT DOCUMENTS**

D. 217,193 4/1970 Lindsay ..... D12/344

D. 326,255 5/1992 Graham et al. .... D12/319  
D. 337,095 7/1993 Simonov et al. .... D12/344  
D. 351,822 10/1994 Simonov et al. .... D12/344

*Primary Examiner*—Kay H. Chin  
*Attorney, Agent, or Firm*—Eckert Seamans Cherin & Mellott

[57] **CLAIM**

The ornamental design for aircraft, as shown and described.

**DESCRIPTION**

FIG. 1 is a front view of the aircraft of the invention; and, FIG. 2 is a rear view of the aircraft;  
FIG. 3 is a perspective view of the aircraft from the left side and above;  
FIG. 4 is a perspective view thereof, from the right side and above;  
FIG. 5 is a perspective view from the right front underside; and,  
FIG. 6 is a perspective view of the aircraft from the left rear underside.

**1 Claim, 6 Drawing Sheets**

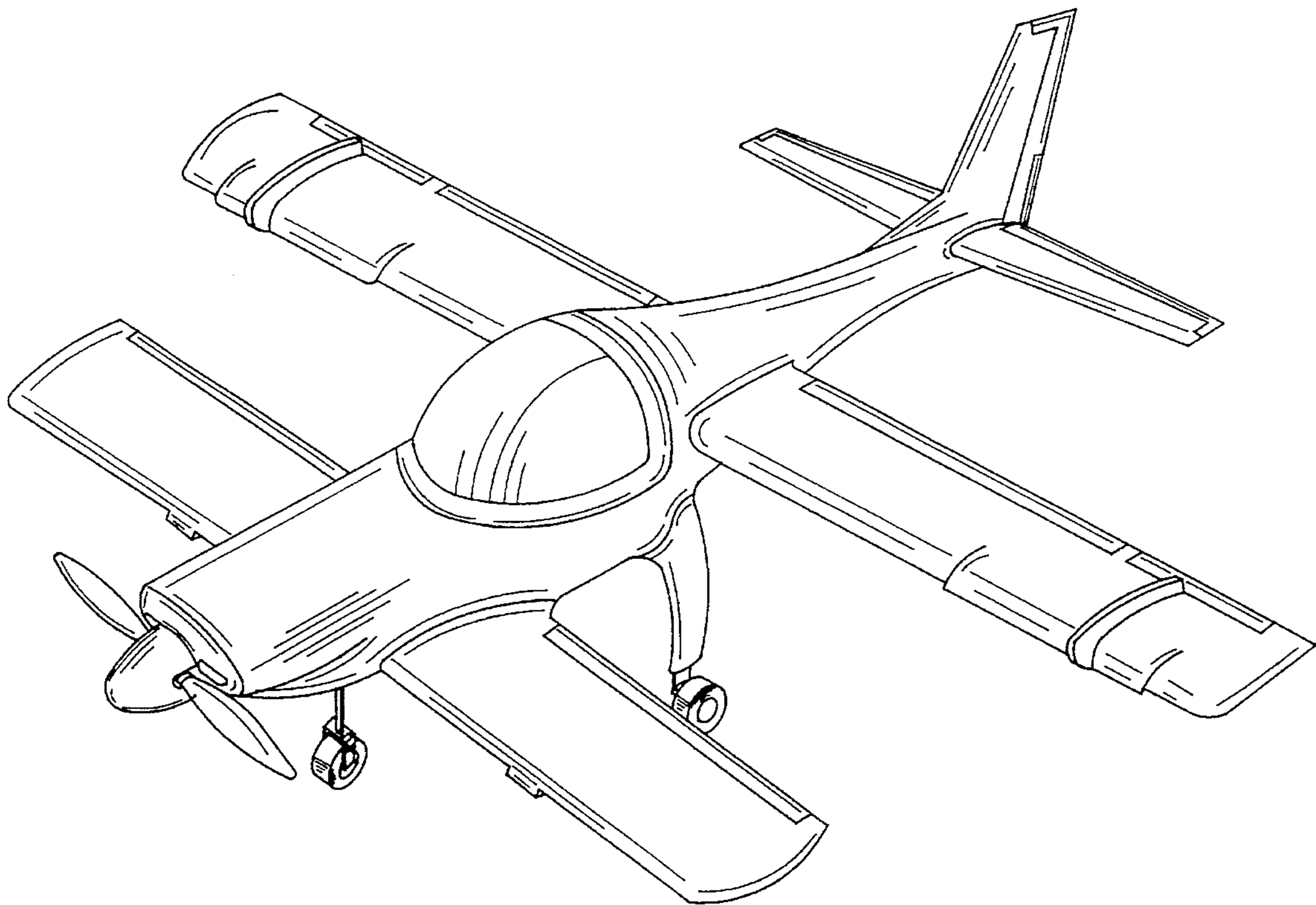

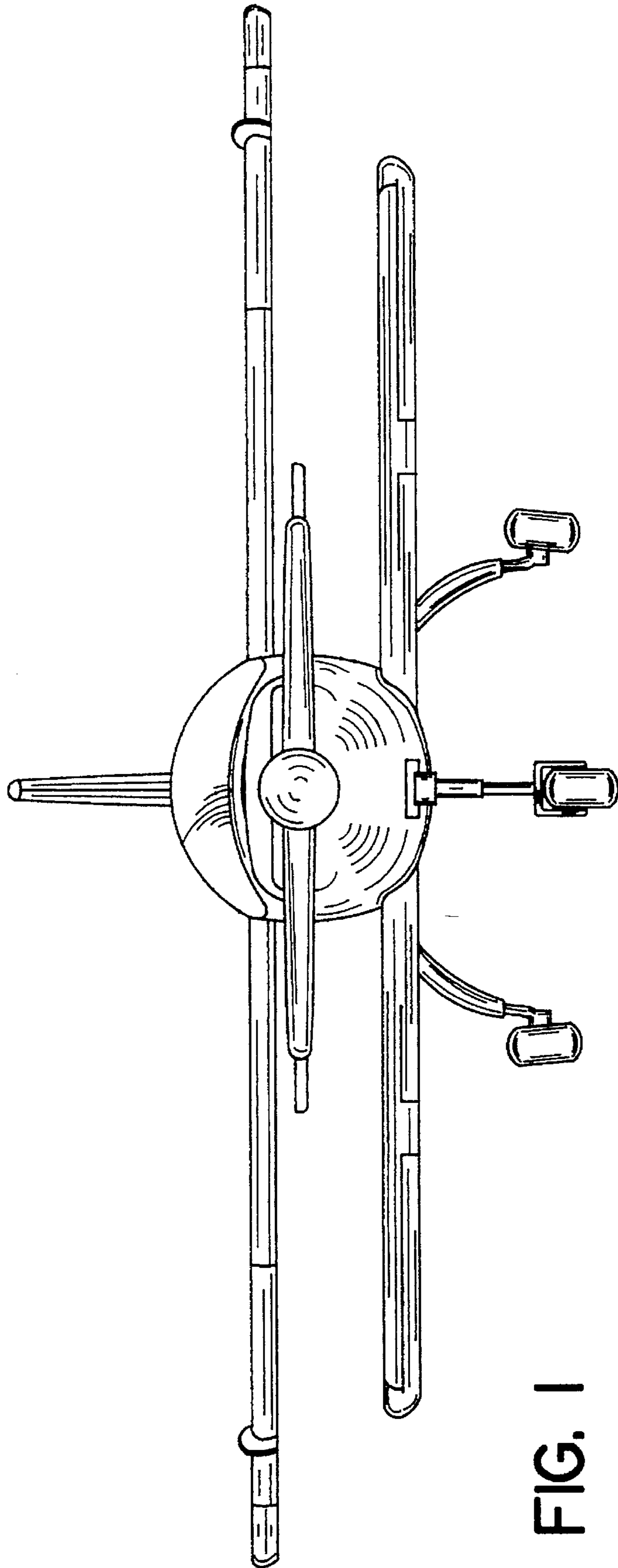

FIG. 1

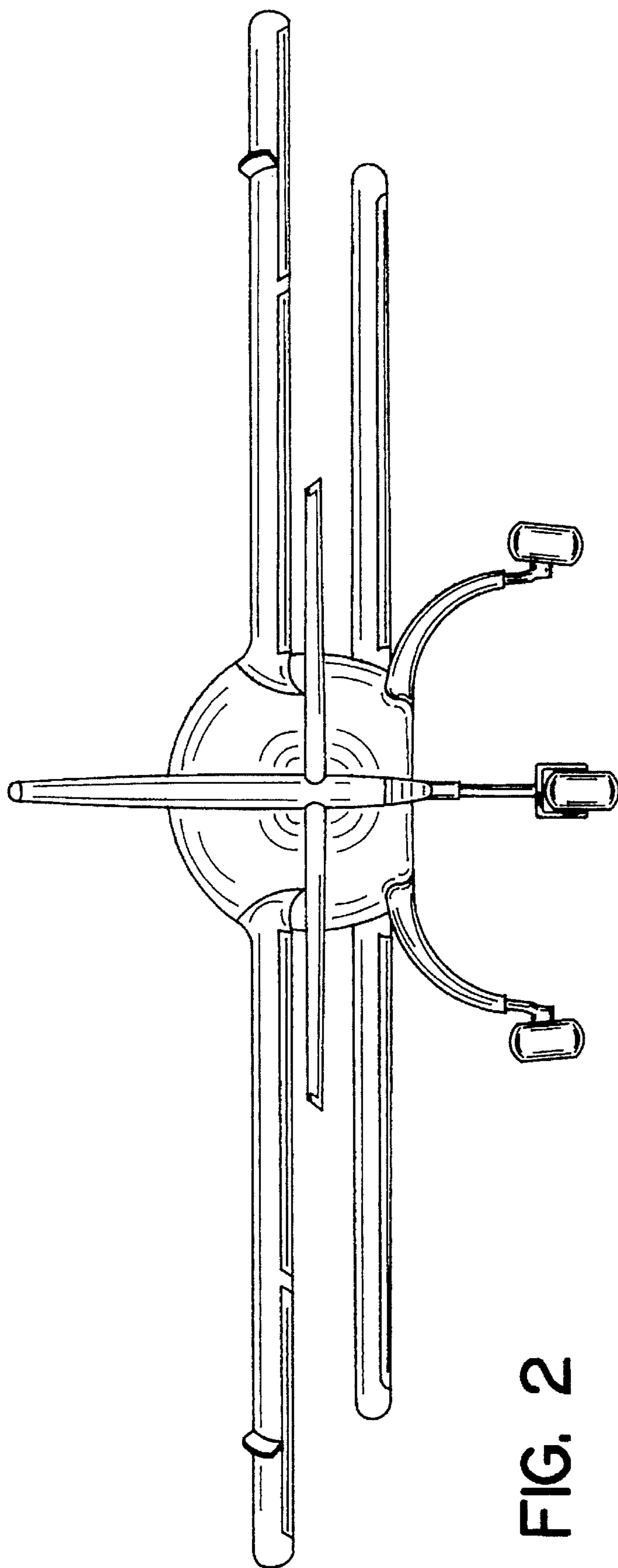

FIG. 2

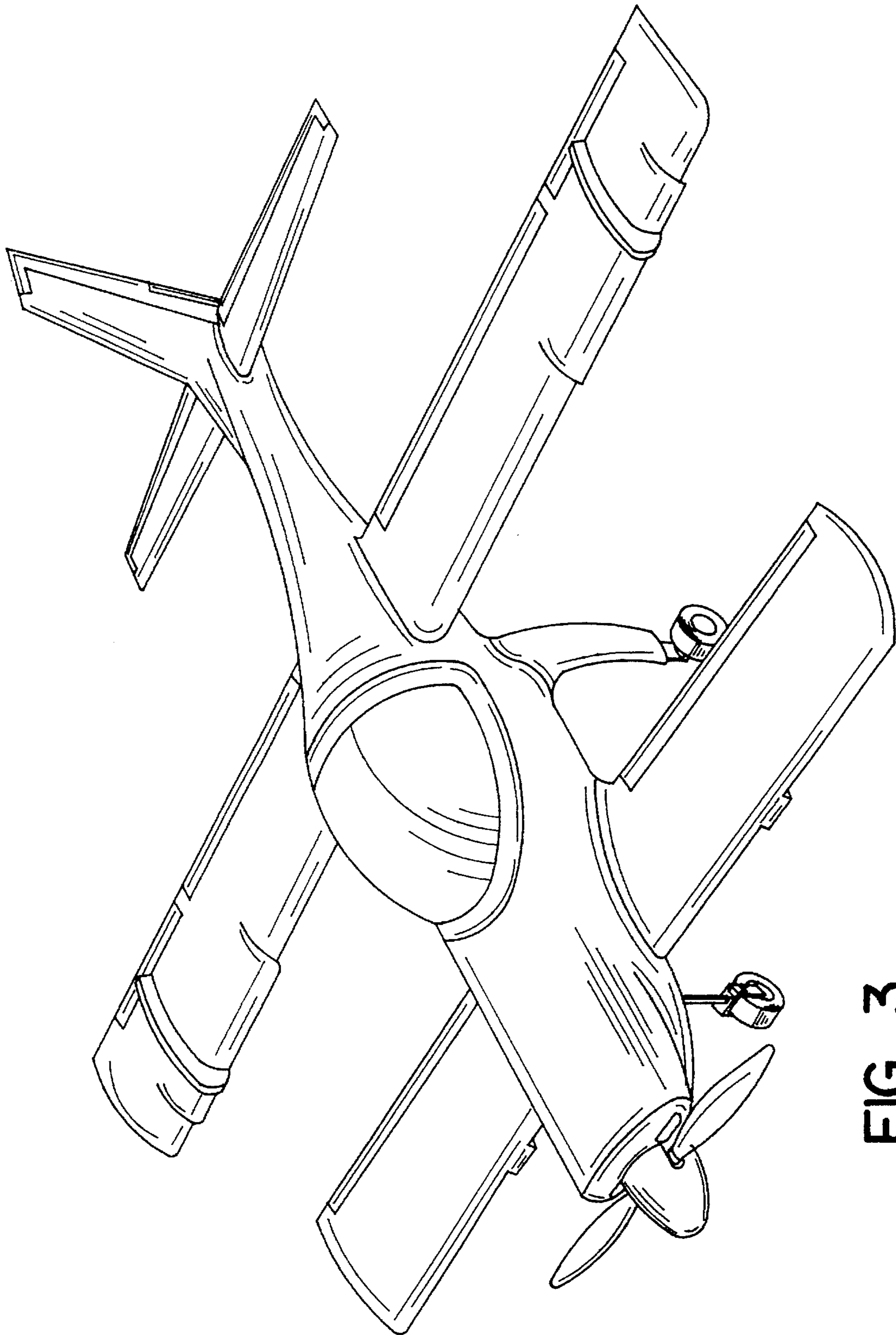

FIG. 3

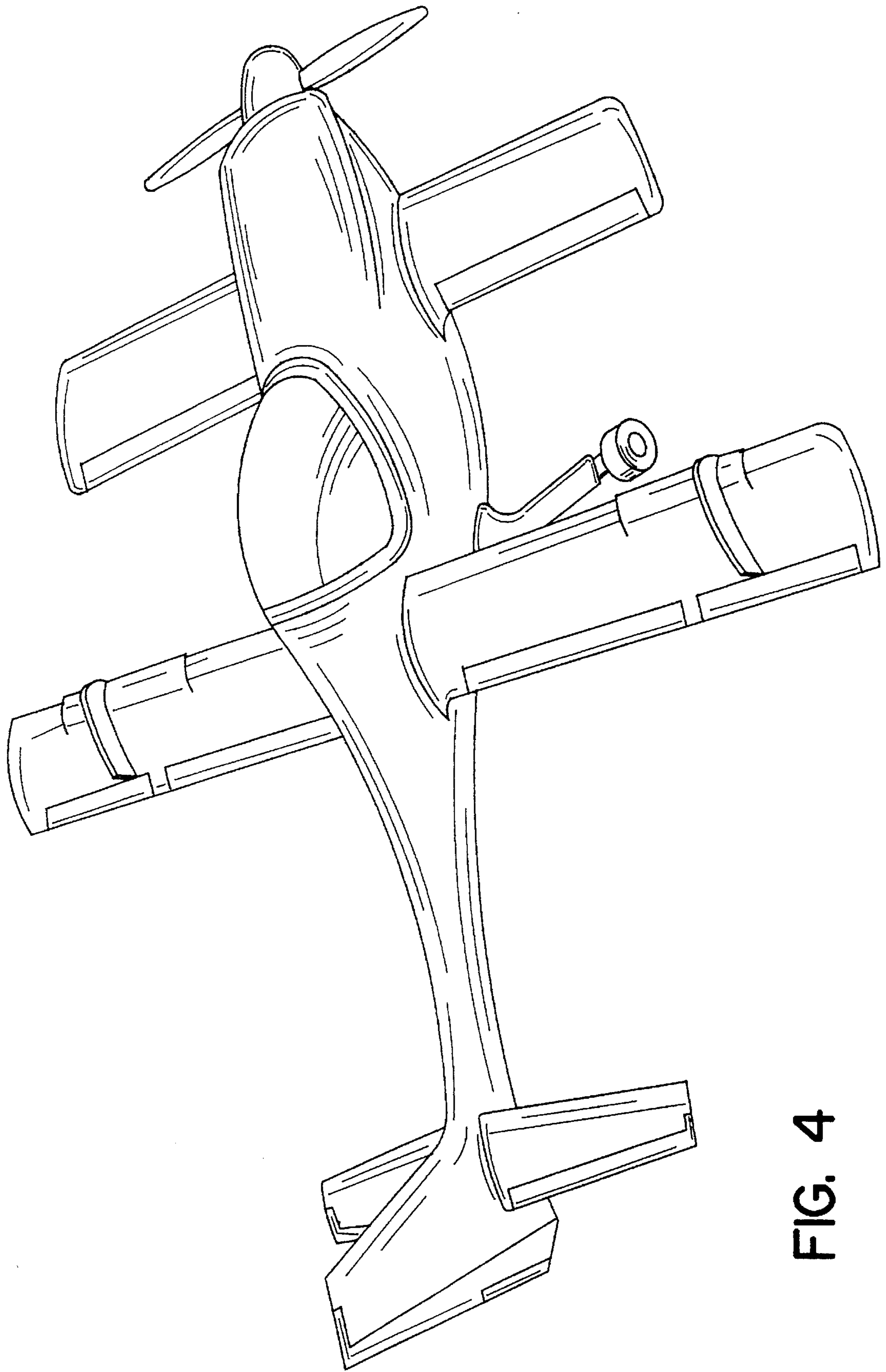

FIG. 4

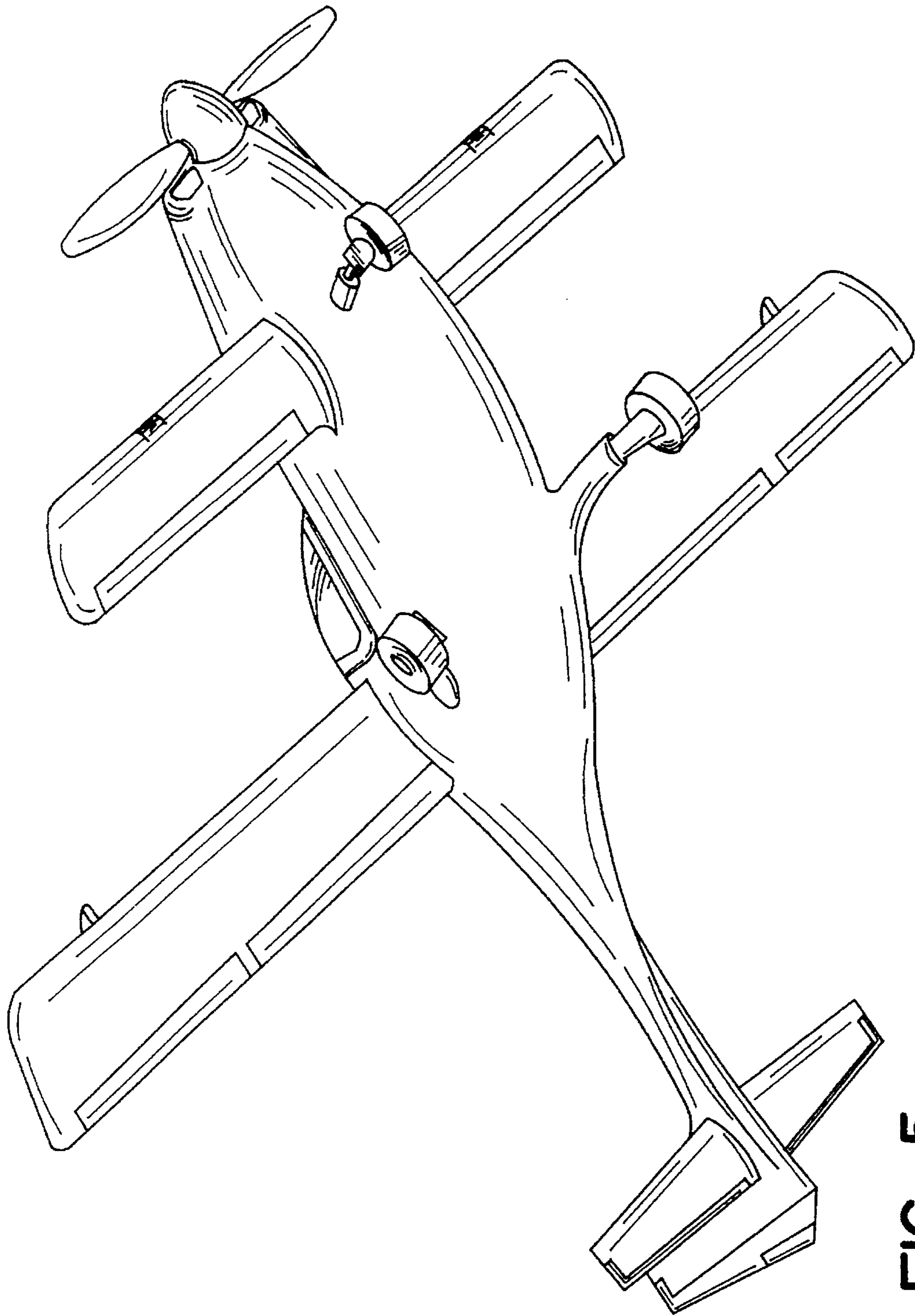

FIG. 5

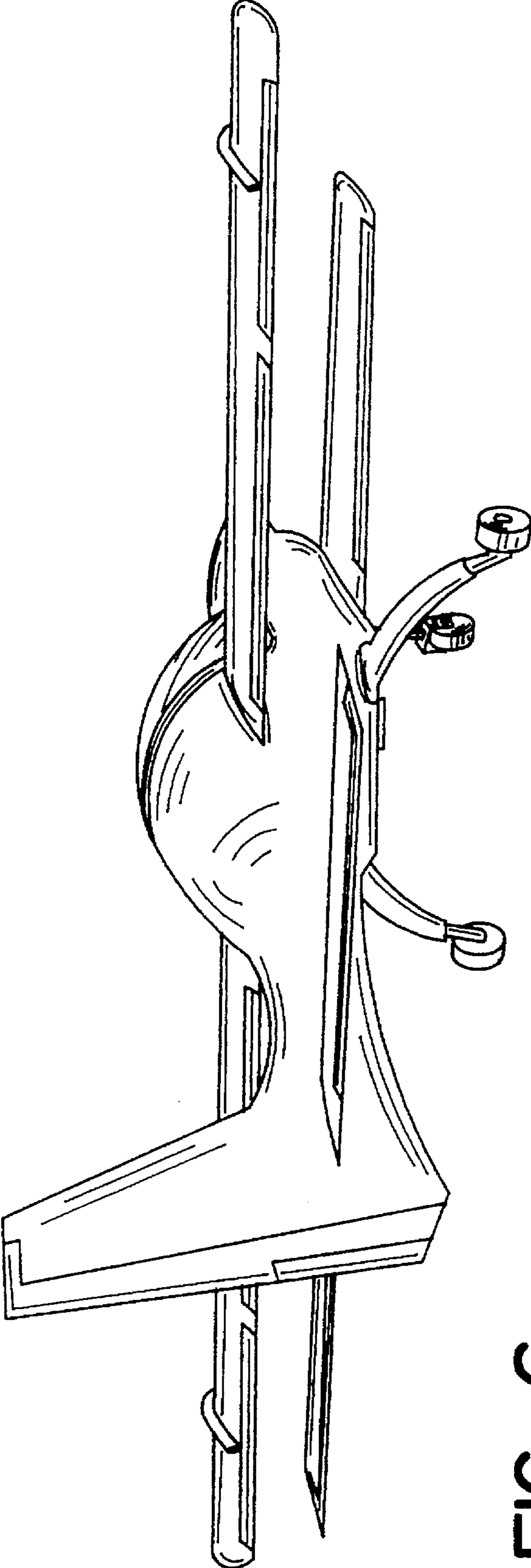

FIG. 6