



US00D371104S

United States Patent [19]

[11] Patent Number: **Des. 371,104**

Frigard

[45] Date of Patent: ****Jun. 25, 1996**

[54] **BOAT DECK**

5,377,607 1/1995 Ross .
5,392,726 2/1995 Benze .

[75] Inventor: **Charles R. Frigard**, Newbury Park, Calif.

Primary Examiner—Kay H. Chin
Attorney, Agent, or Firm—Dorsey & Whitney

[73] Assignee: **NorthStar Marine, Inc.**, Mound, Minn.

[57] **CLAIM**

[**] Term: **14 Years**

The ornamental design for a boat deck, as shown and described.

[21] Appl. No.: **42,195**

DESCRIPTION

[22] Filed: **Aug. 3, 1995**

[52] U.S. Cl. **D12/318**; D12/304

[58] Field of Search D12/300, 303,
D12/304, 315, 318; 114/61, 39.1

FIG. 1 is a right side perspective view of a boat deck showing my new design;
FIG. 2 is a right side elevational view thereof;
FIG. 3 is a left side elevational view thereof;
FIG. 4 is a front elevational view thereof;
FIG. 5 is a rear elevational view thereof;
FIG. 6 is a top plan view thereof; and,
FIG. 7 is a bottom plan view thereof.

[56] References Cited

U.S. PATENT DOCUMENTS

- D. 289,392 4/1987 Gary et al. .
- D. 324,021 2/1992 Walker .
- 4,730,570 3/1988 Harris .
- 4,836,120 6/1989 Murphy 114/61
- 5,189,974 3/1993 Masters .
- 5,235,925 8/1993 Farrier .

The broken line showing of environmental structure in FIGS. 1-7 in the drawings is for illustrative purposes only and forms no part of the claimed design.

1 Claim, 4 Drawing Sheets

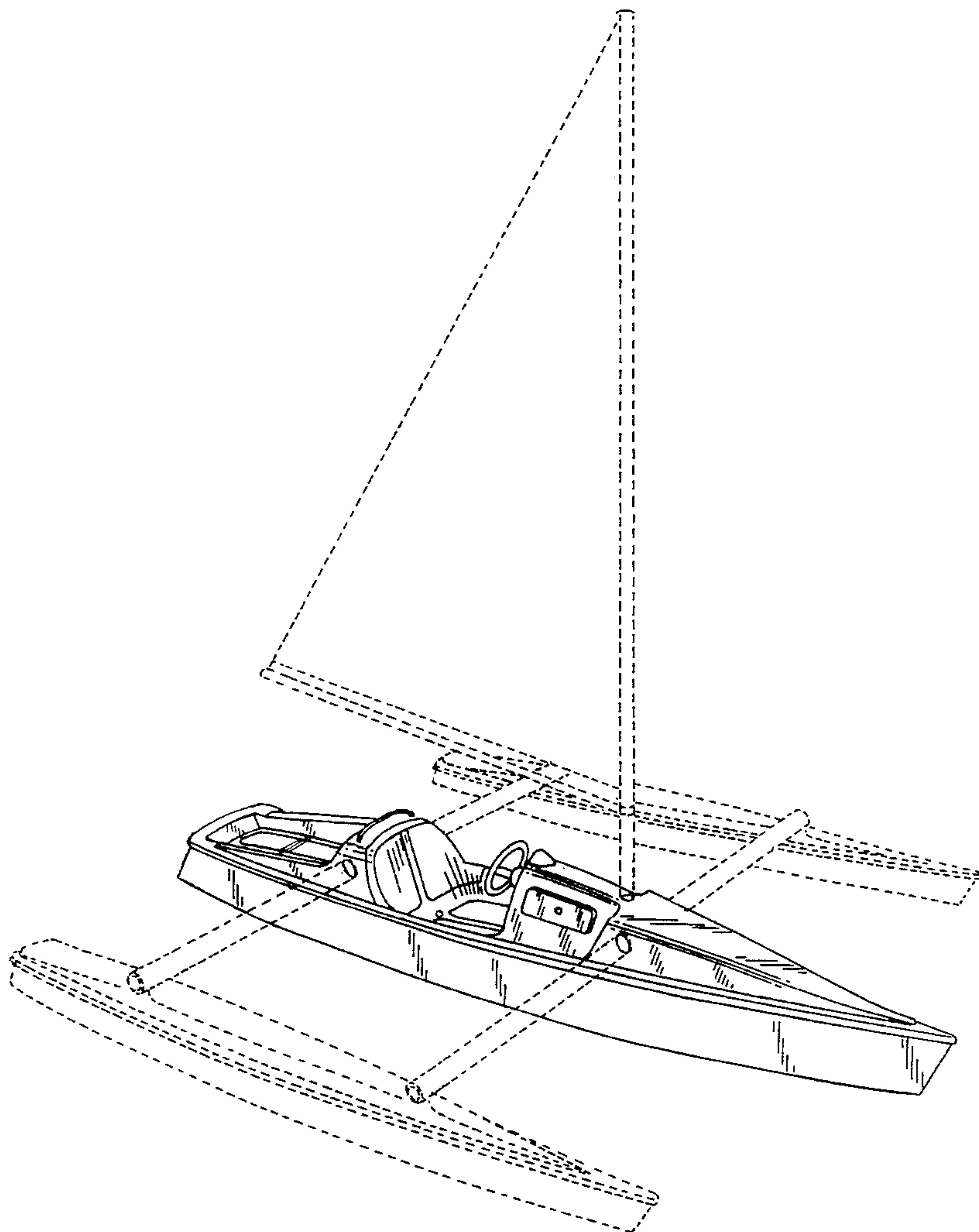

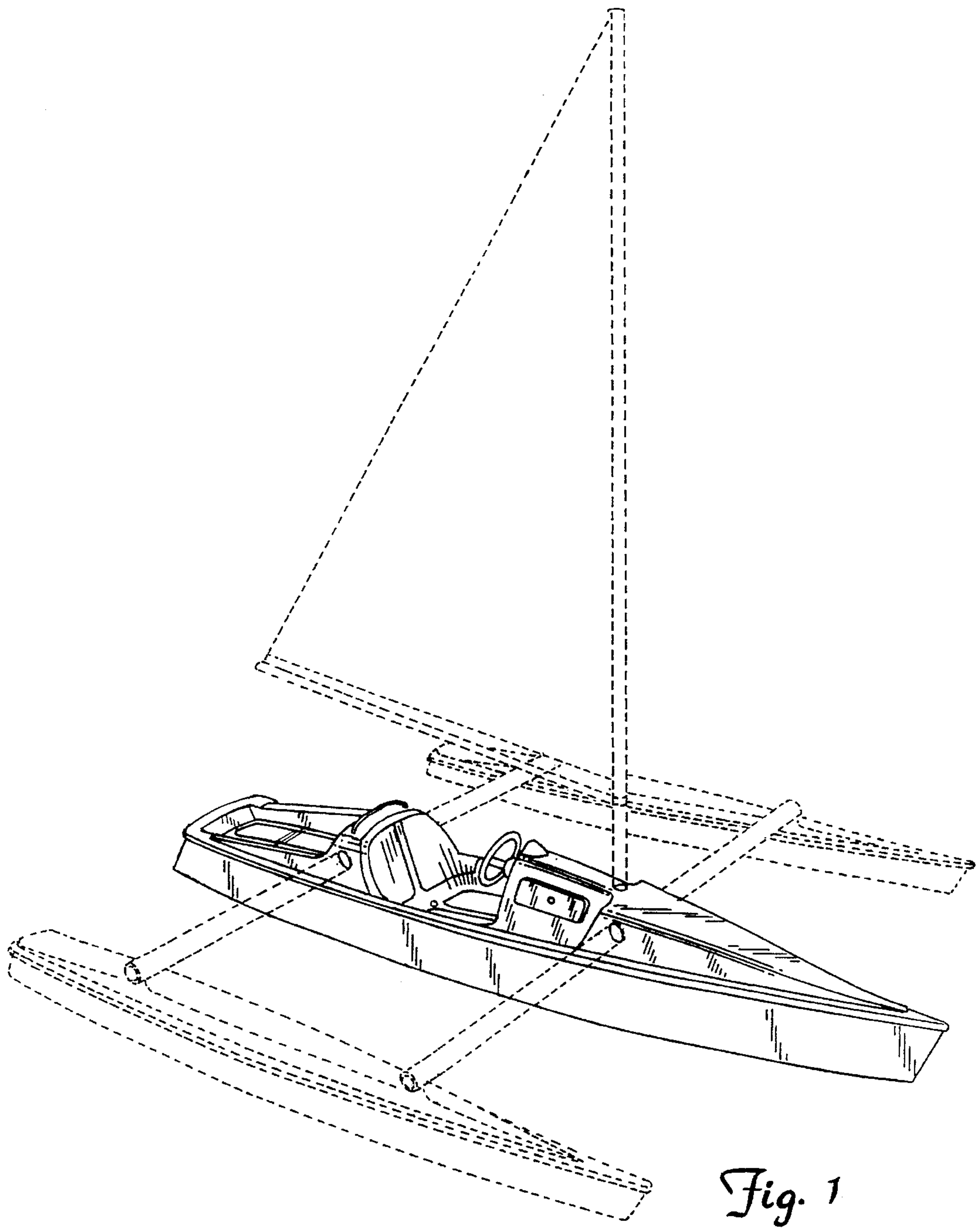
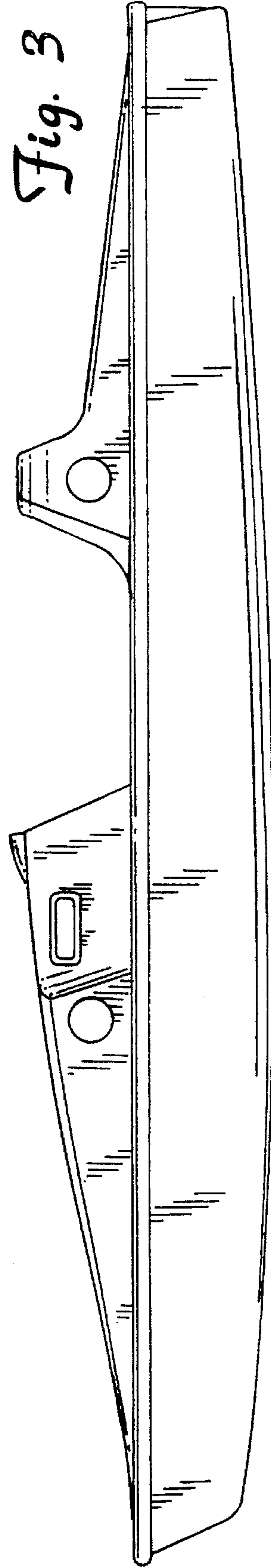
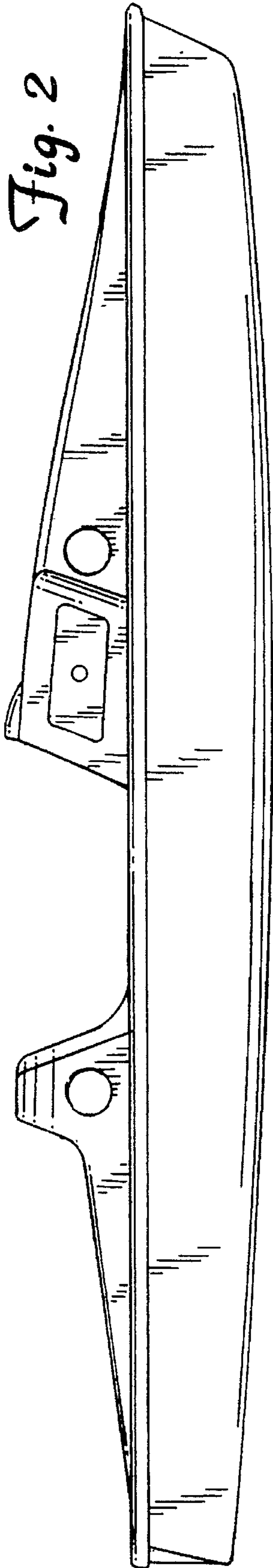

Fig. 1



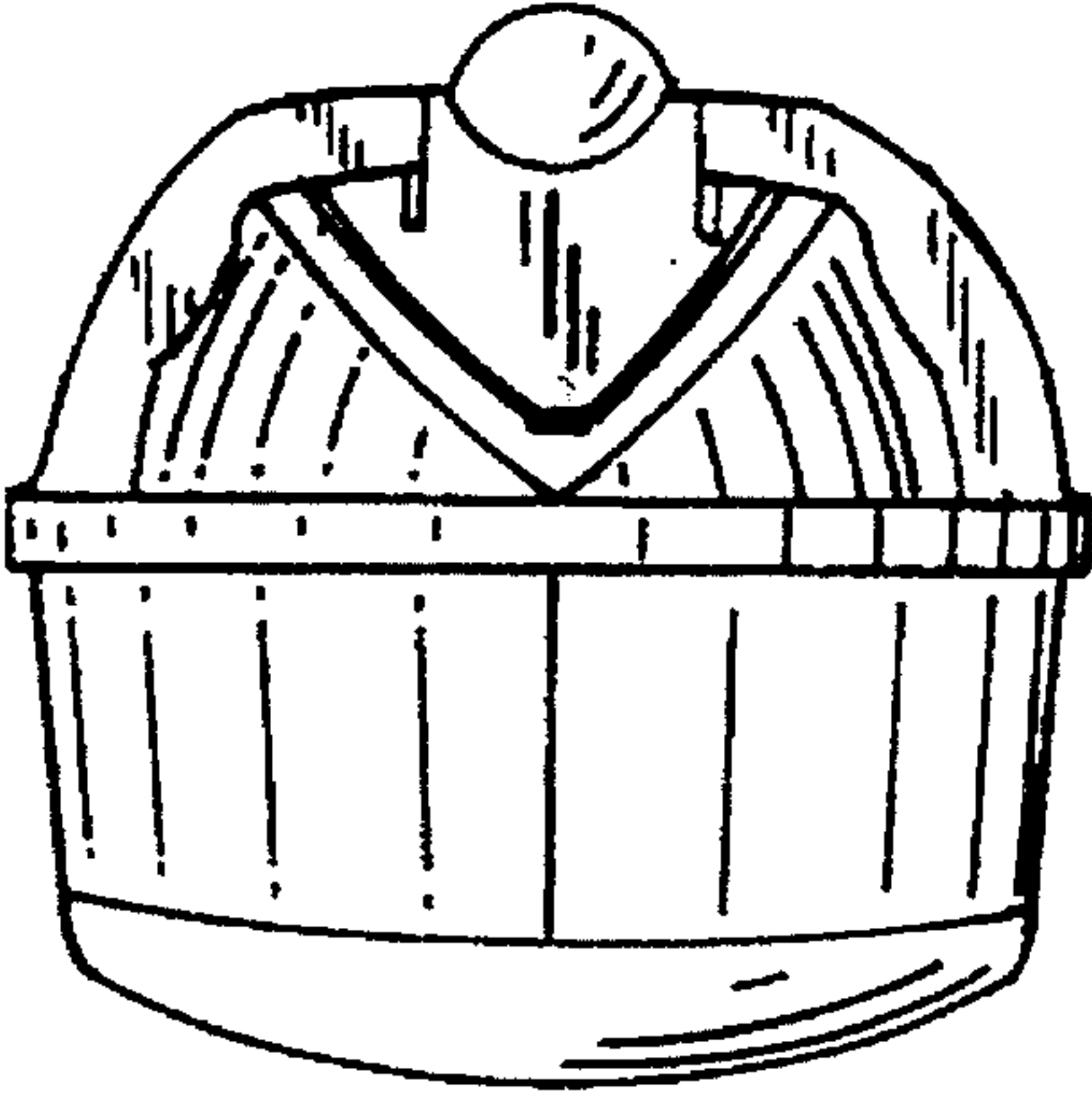

Fig. 4

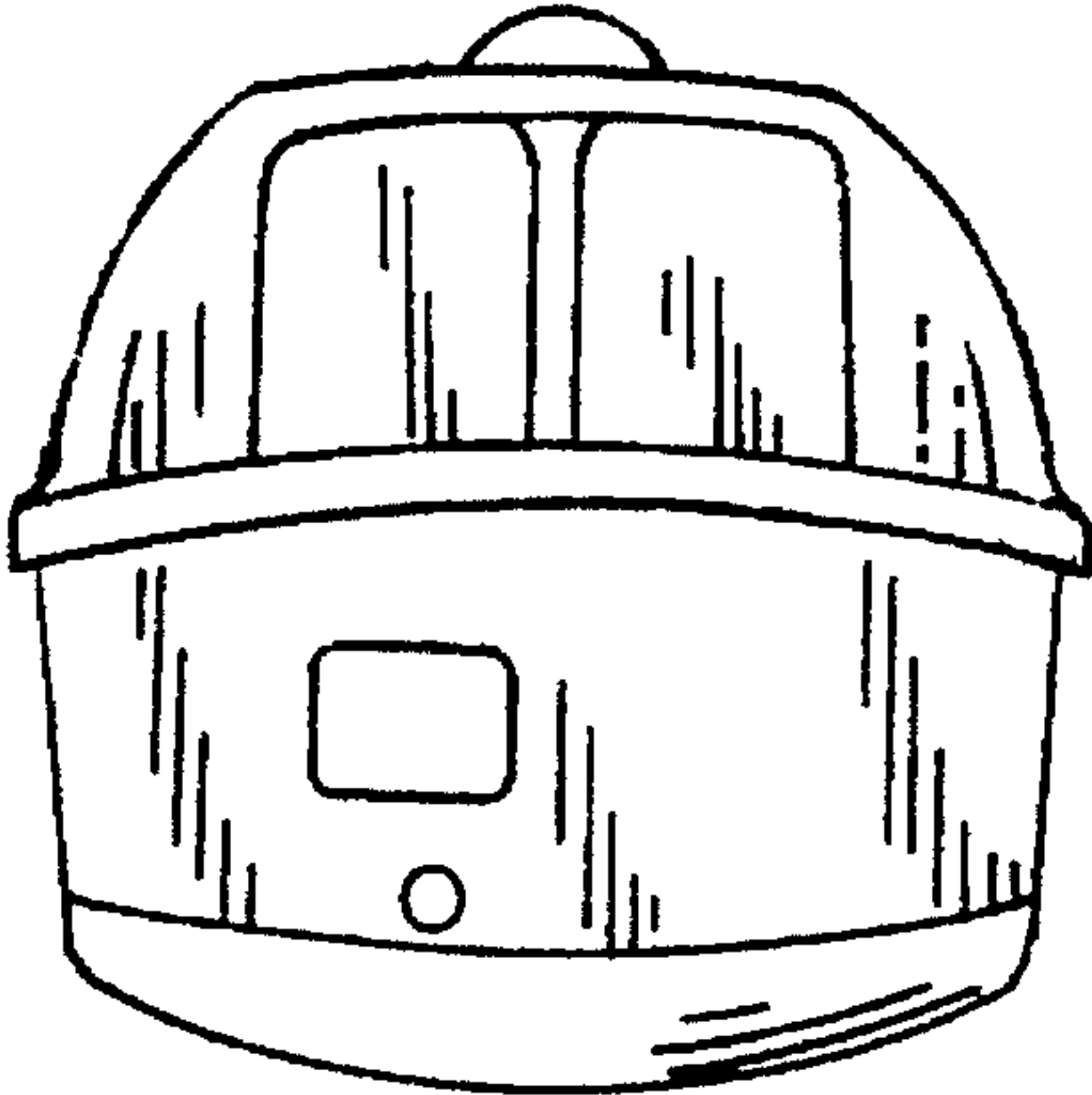

Fig. 5

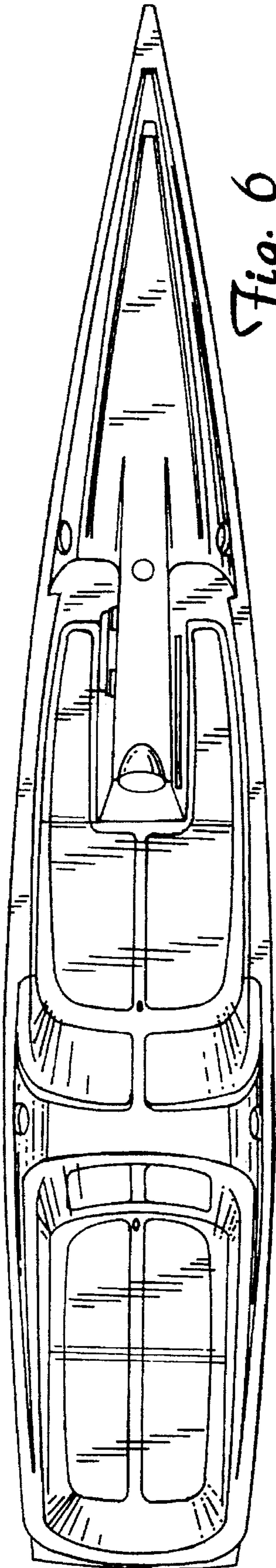

Fig. 6

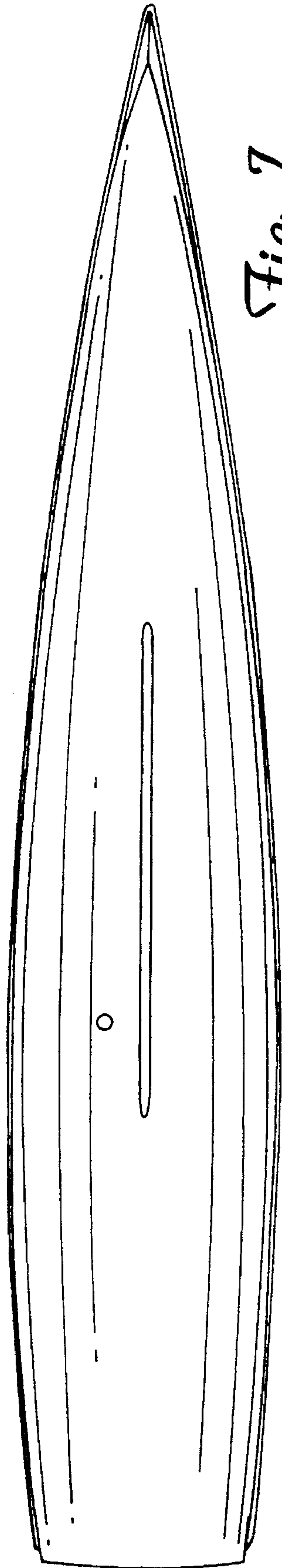

Fig. 7

UNITED STATES PATENT AND TRADEMARK OFFICE
CERTIFICATE OF CORRECTION

PATENT NO. : Des. 371,104
DATED : June 25, 1996
INVENTOR(S) : Charles Raymond Frigard

Page 1 of 6

It is certified that error appears in the above-identified patent and that said Letters Patent is hereby corrected as shown below:

The title page should be deleted to appear as per attached.

The drawing sheets consisting of Figs, 1-7 should be deleted to appear as per attached.

Signed and Sealed this _
Twelfth Day of November, 1996

Attest:



BRUCE LEHMAN

Attesting Officer

Commissioner of Patents and Trademarks

United States Patent [19]
Frigard

[11] **Patent Number:** **Des. 371,104**

[45] **Date of Patent:** ****Jun. 25, 1996**

[54] **BOAT DECK**

5,377,607 1/1995 Ross .
5,392,726 2/1995 Benze .

[75] **Inventor:** **Charles R. Frigard**, Newbury Park, Calif.

Primary Examiner—Kay H. Chin
Attorney, Agent, or Firm—Dorsey & Whitney

[73] **Assignee:** **NorthStar Marine, Inc.**, Mound, Minn.

[57] **CLAIM**

[**] **Term:** **14 Years**

The ornamental design for a boat deck, as shown and described.

[21] **Appl. No.:** **42,195**

DESCRIPTION

[22] **Filed:** **Aug. 3, 1995**

[52] **U.S. CL.** **D12/318; D12/304**

[58] **Field of Search** **D12/300, 303, D12/304, 315, 318; 114/61, 39.1**

FIG. 1 is a right side perspective view of a boat deck showing my new design;
FIG. 2 is a right side elevational view thereof;
FIG. 3 is a left side elevational view thereof;
FIG. 4 is a front elevational view thereof;
FIG. 5 is a rear elevational view thereof;
FIG. 6 is a top plan view thereof; and,
FIG. 7 is a bottom plan view thereof.
The broken line showing of environmental structure in FIGS. 1-7 in the drawings is for illustrative purposes only and forms no part of the claimed design.

[56] **References Cited**

U.S. PATENT DOCUMENTS

- D. 289,392 4/1987 Gary et al. .
- D. 324,021 2/1992 Walker .
- 4,730,570 3/1988 Harris .
- 4,836,120 6/1989 Murphy 114/61
- 5,189,974 3/1993 Masters .
- 5,235,925 8/1993 Farrier .

1 Claim, 4 Drawing Sheets

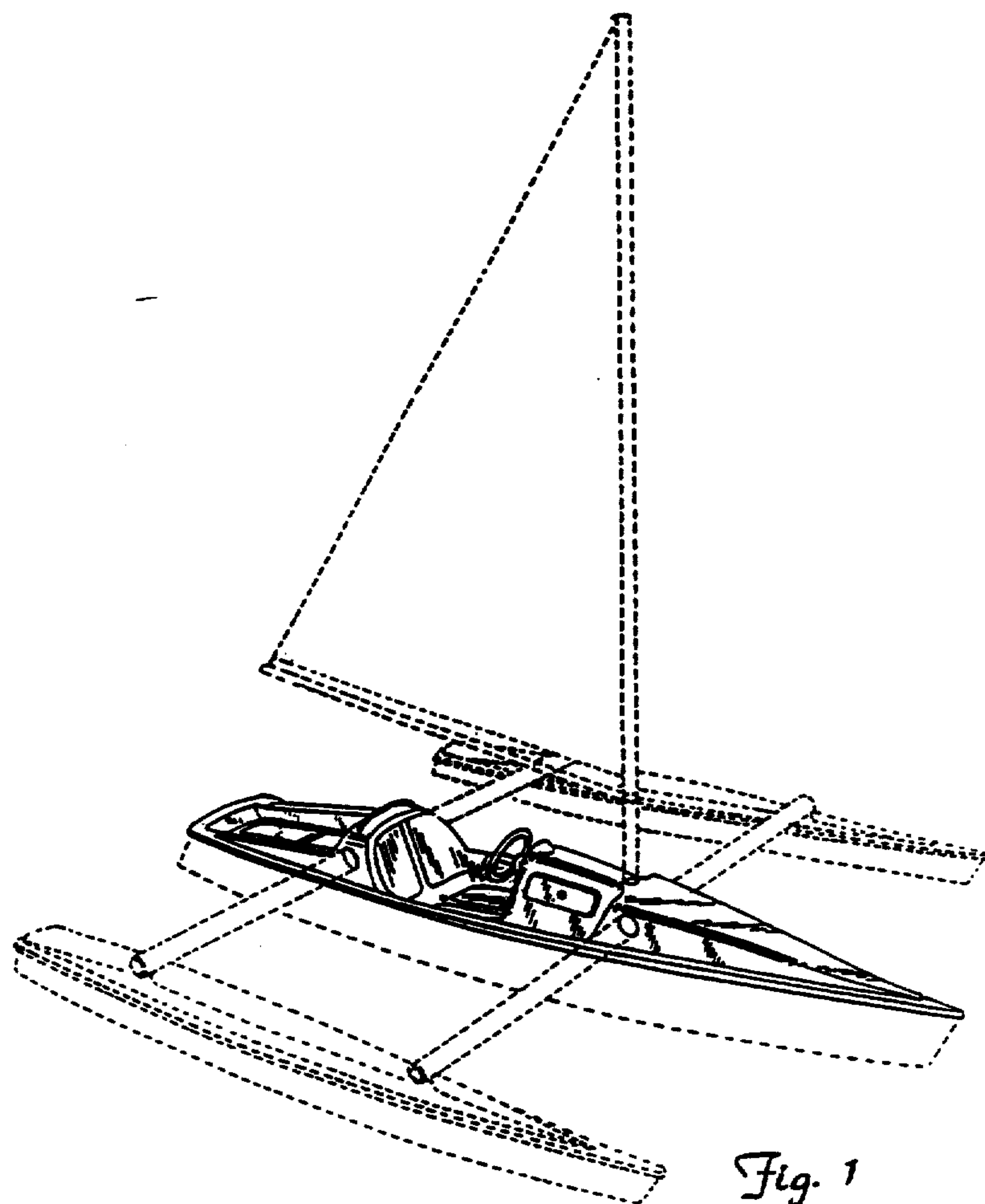

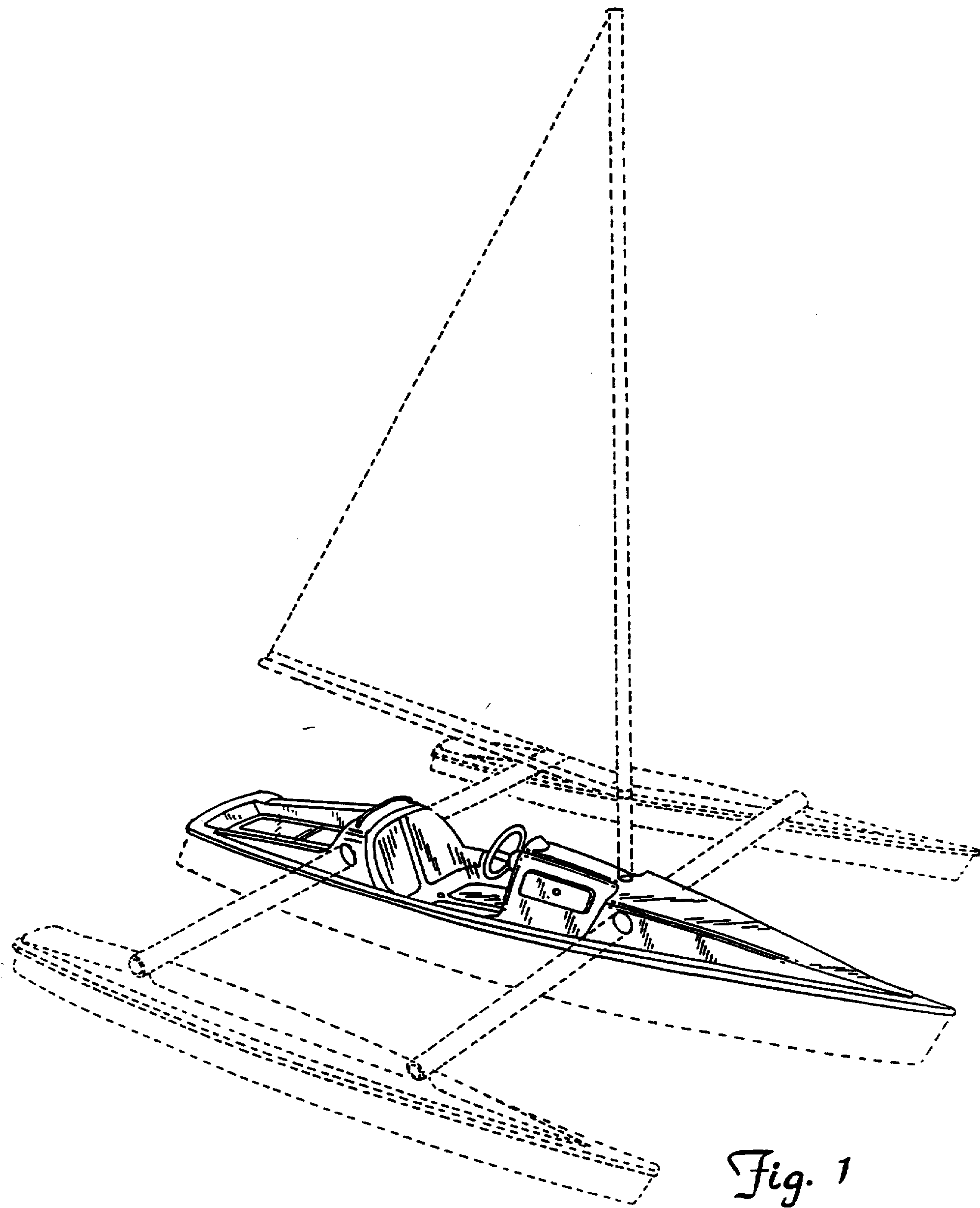

Fig. 1

Fig. 2

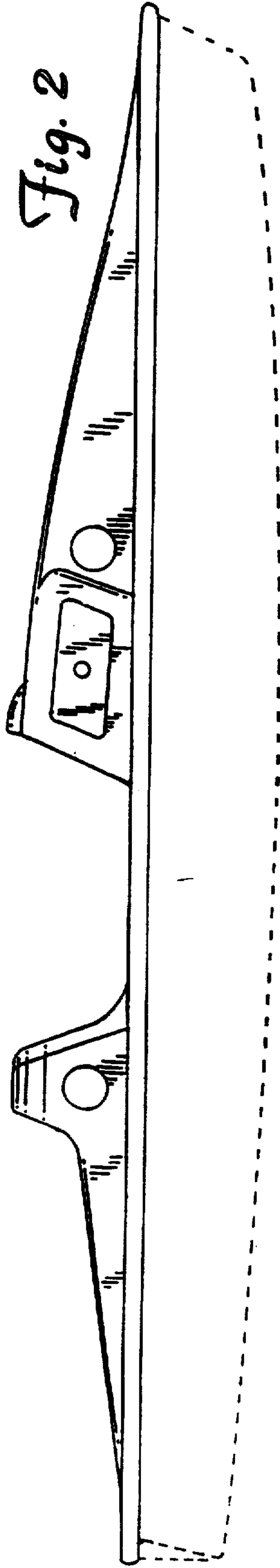
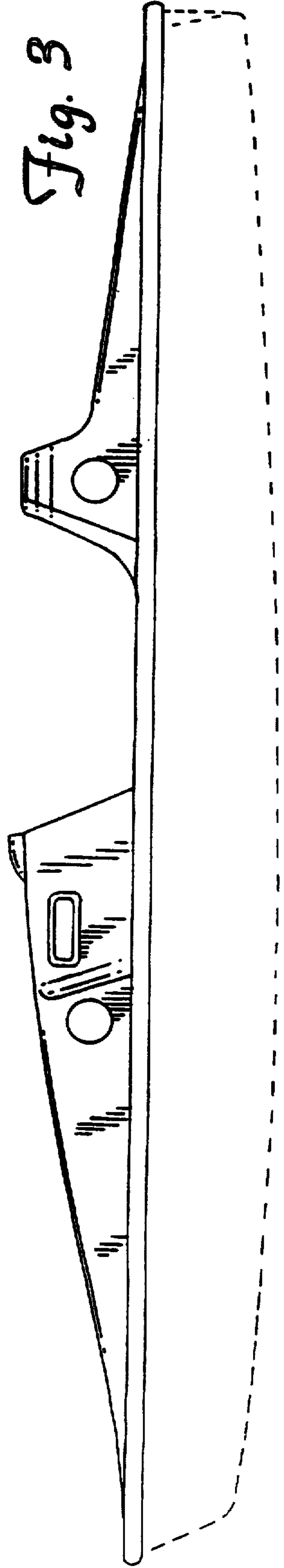

Fig. 3



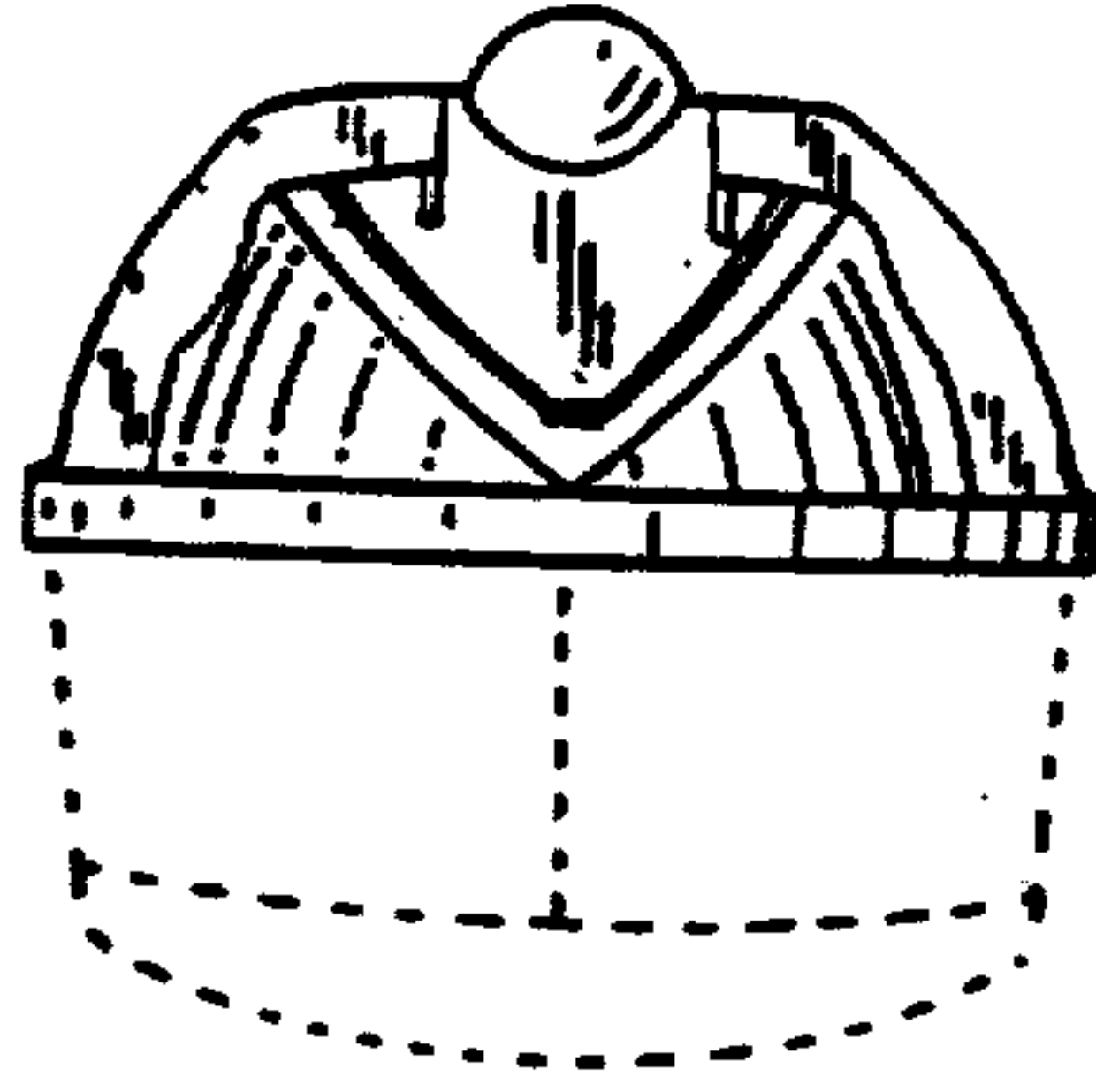

Fig. 4

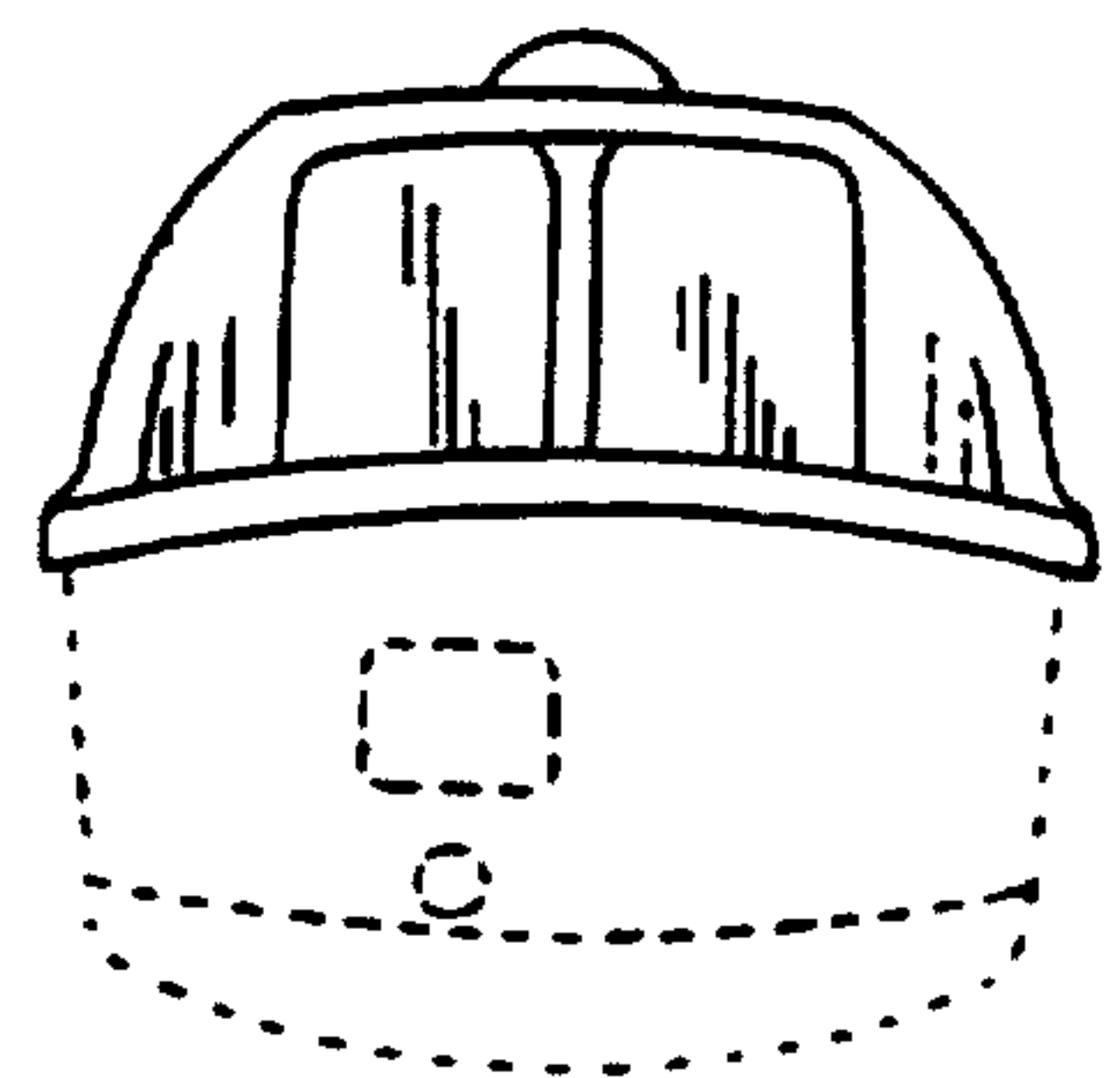

Fig. 5

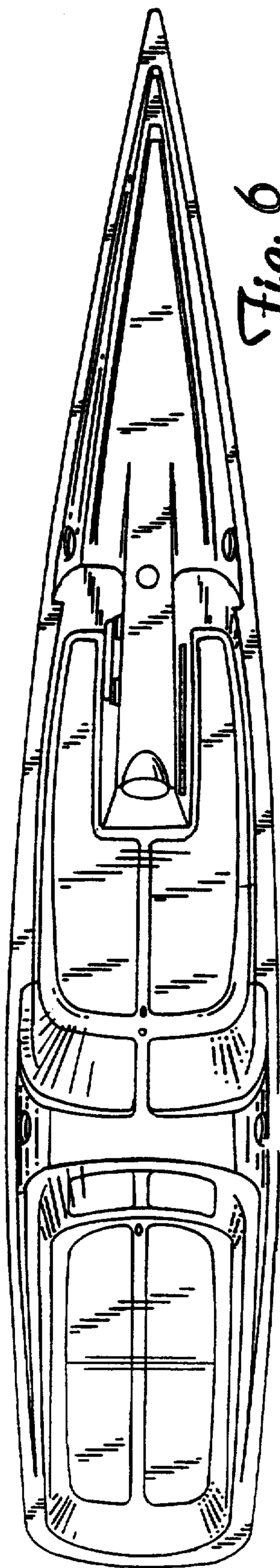

Fig. 6

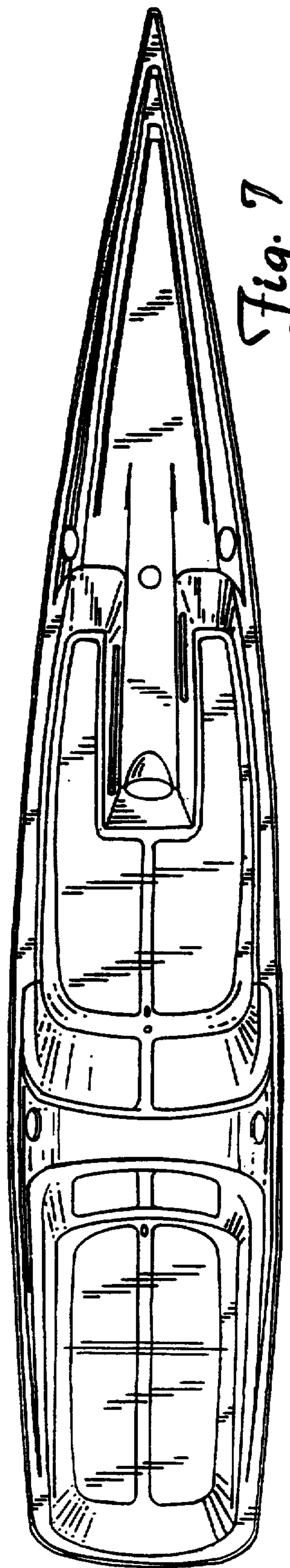

Fig. 7