



US00D371093S

United States Patent [19]

[11] Patent Number: **Des. 371,093**

Allsop et al.

[45] Date of Patent: ****Jun. 25, 1996**

[54] BICYCLE FRAME

[75] Inventors: **James D. Allsop; Michael G. Allsop**,
both of Bellingham, Wash.

[73] Assignee: **Softride, Inc.**, Bellingham, Wash.

[**] Term: **14 Years**

[21] Appl. No.: **13,992**

[22] Filed: **Oct. 7, 1993**

Related U.S. Application Data

[62] Division of Ser. No. 947,274, Sep. 18, 1992, Pat. No. 5,415,423.

[52] U.S. Cl. **D12/111**

[58] Field of Search D12/111; 280/281.1,
280/288.1, 288.2, 288.3

[56] References Cited

U.S. PATENT DOCUMENTS

D. 45,219	2/1914	Allen	280/281.1
D. 313,381	1/1991	Moeller	D12/111
D. 347,603	6/1994	Fritschen	D12/111
631,282	8/1899	Dikeman	280/281.1
1,580,414	4/1926	Cozzolino et al.	280/275
2,244,709	6/1941	Kinzel	280/281.1
2,493,037	1/1950	Simon	280/288.3
2,854,249	9/1958	Jaulmes	280/288.3
3,121,575	2/1964	Bourgi	280/236
4,613,146	9/1986	Sharp et al.	280/288.2
4,850,607	7/1989	Trimble	280/281.1
4,934,724	6/1990	Allsop et al.	280/281.1
5,273,303	12/1993	Hornzee-Jones	280/288.3

FOREIGN PATENT DOCUMENTS

336181	4/1921	Germany	280/275
4101998	7/1992	Germany	280/288.2
2-286486	11/1990	Japan	280/288.3
352342	7/1931	United Kingdom	280/288.3

OTHER PUBLICATIONS

ZIPP 2001 material, (four-page brochure and 4 photographs), 1991.

Primary Examiner—A. Hugo Word

Assistant Examiner—M. Brown

Attorney, Agent, or Firm—Christensen O'Connor Johnson & Kindness

[57] CLAIM

The ornamental design for a bicycle frame, as shown and described.

DESCRIPTION

FIG. 1 is a perspective view of a bicycle frame showing our new design;

FIG. 2 is a left side view, the broken lines are shown for illustrative purposes only and form no part of the claimed design;

FIG. 3 is a right side view of the bicycle frame;

FIG. 4 is a left side view of the bicycle frame;

FIG. 5 is a front view of the bicycle frame;

FIG. 6 is a back view of the bicycle frame;

FIG. 7 is a bottom view of the bicycle frame; and,

FIG. 8 is a top view of the bicycle frame.

1 Claim, 4 Drawing Sheets

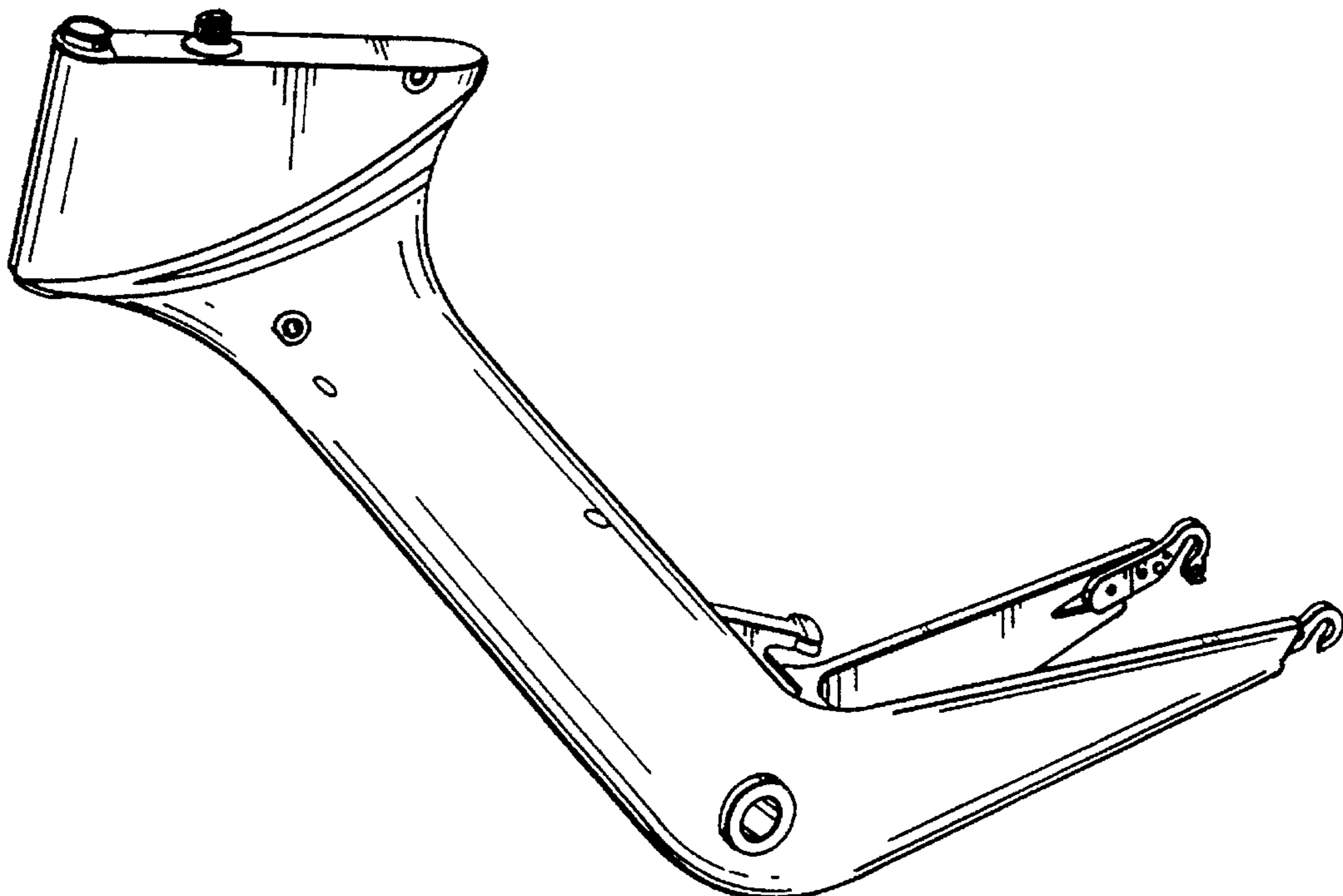

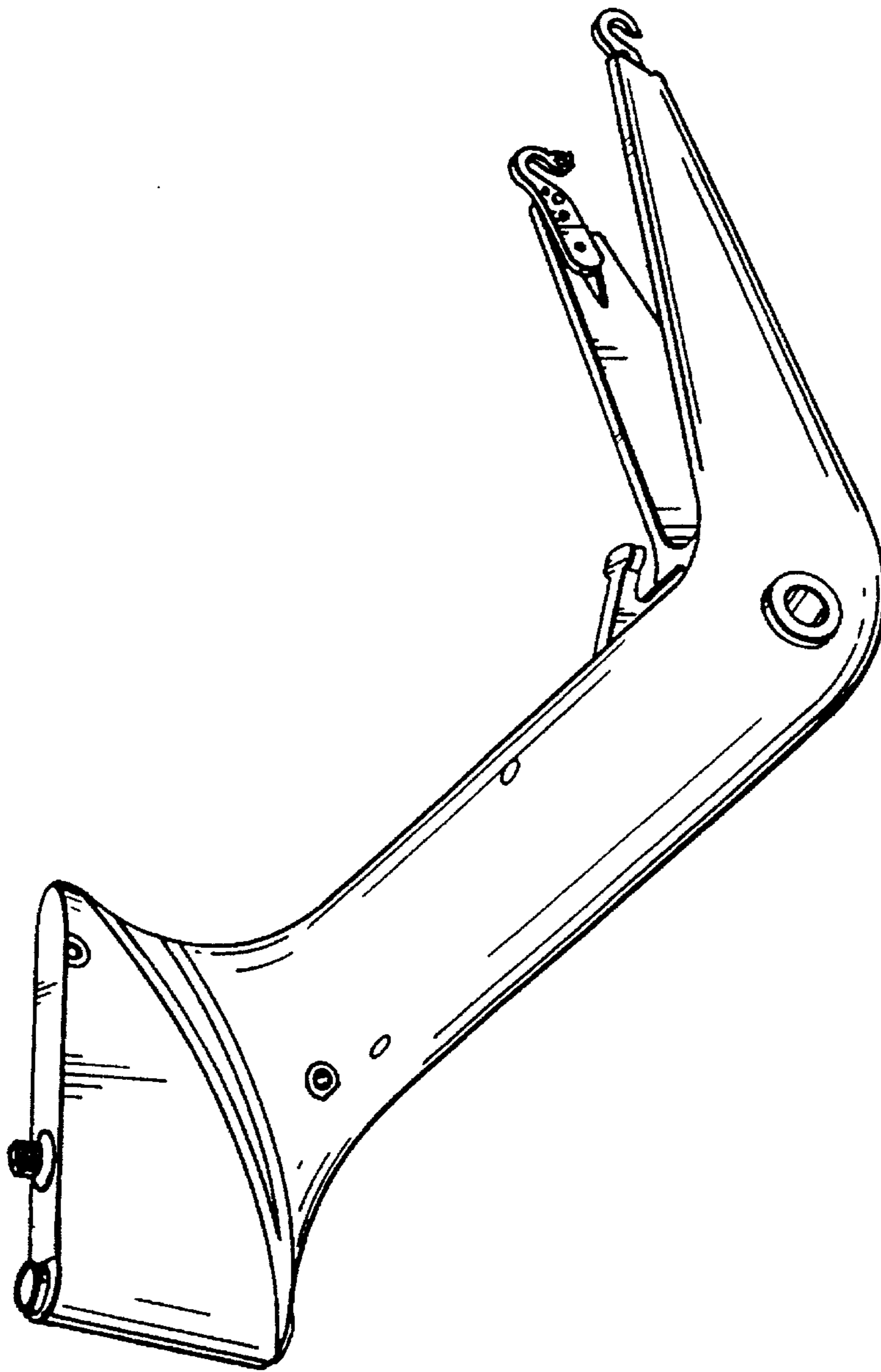
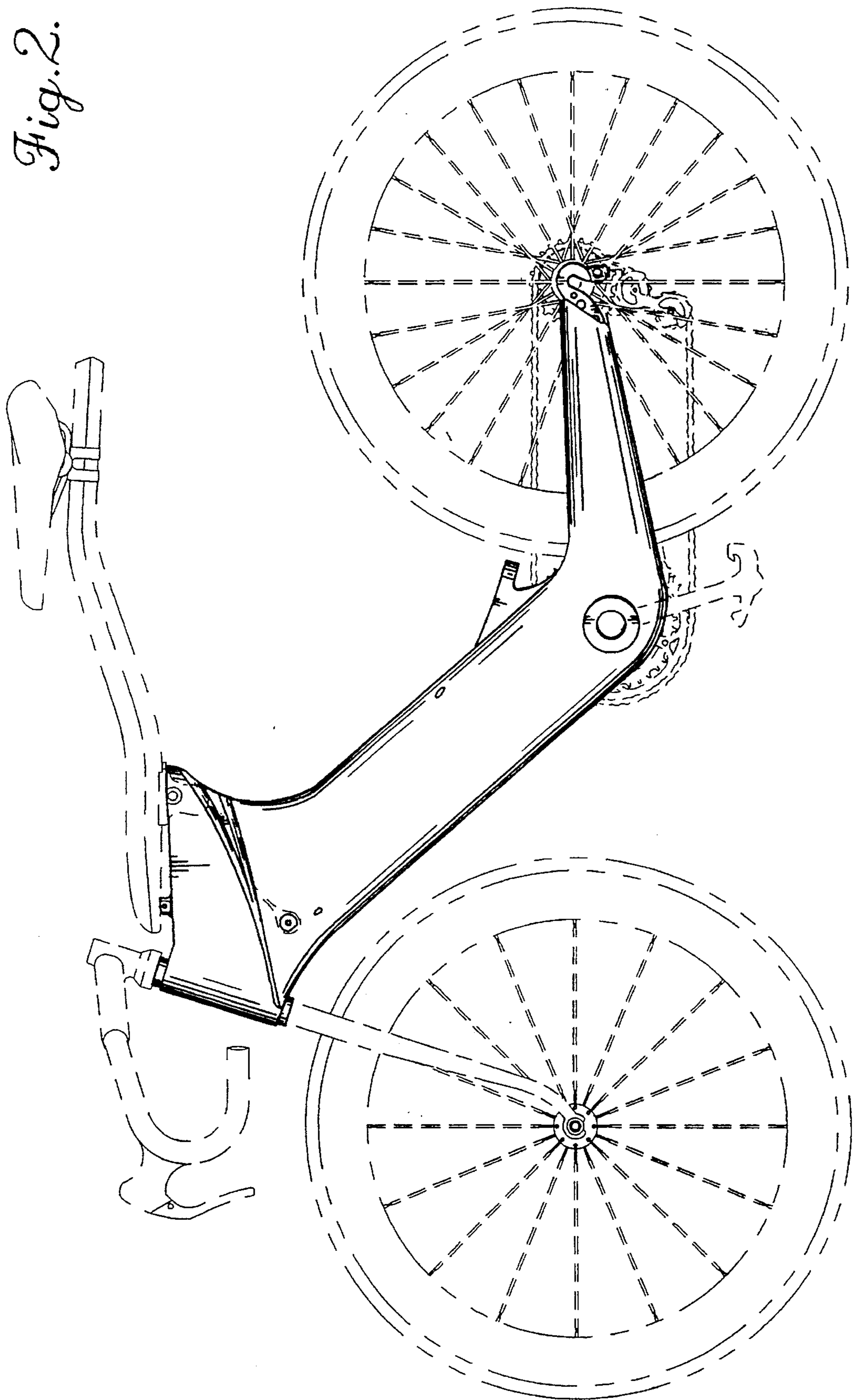

Fig. 1.

Fig. 2.



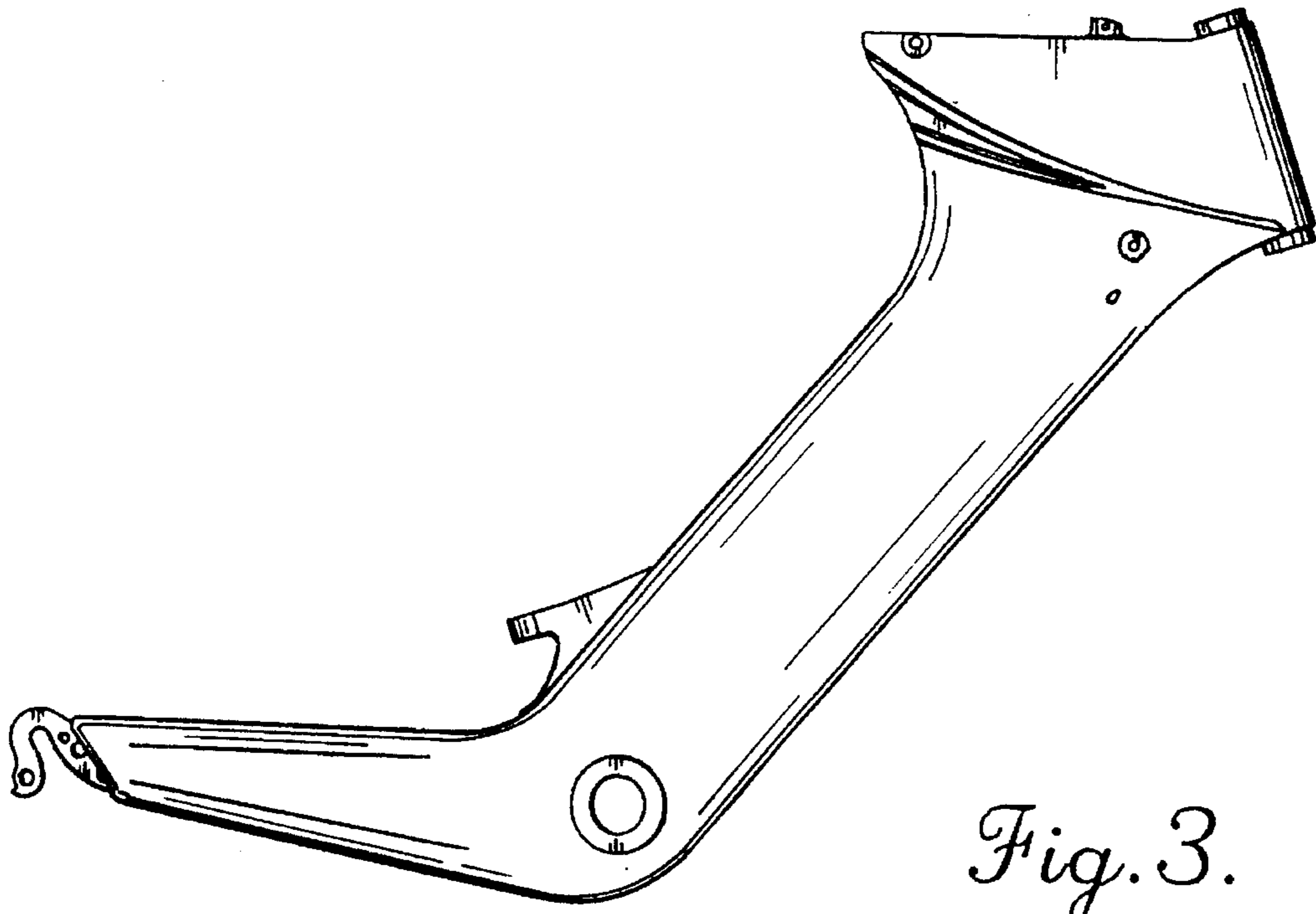

Fig. 3.

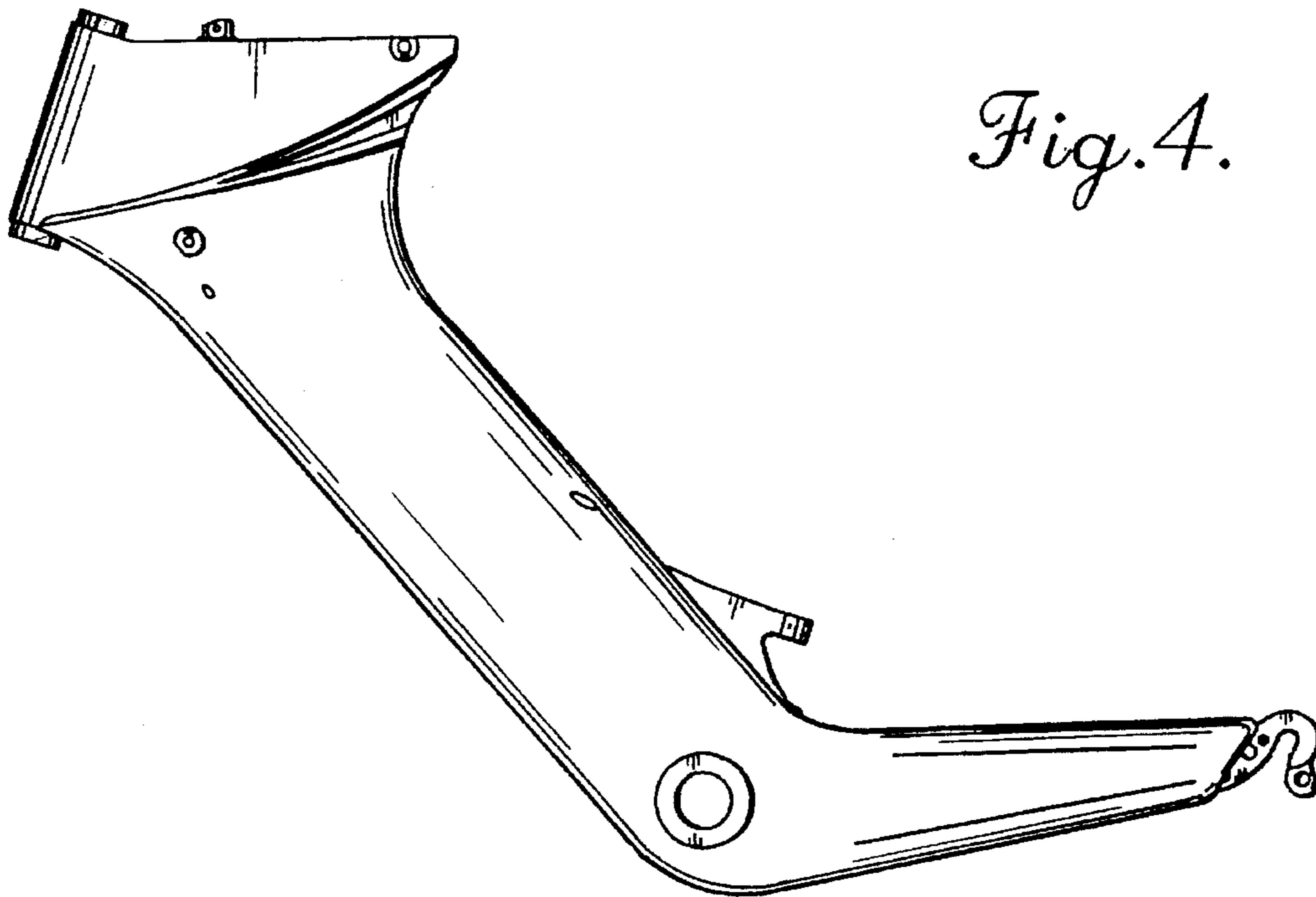

Fig. 4.

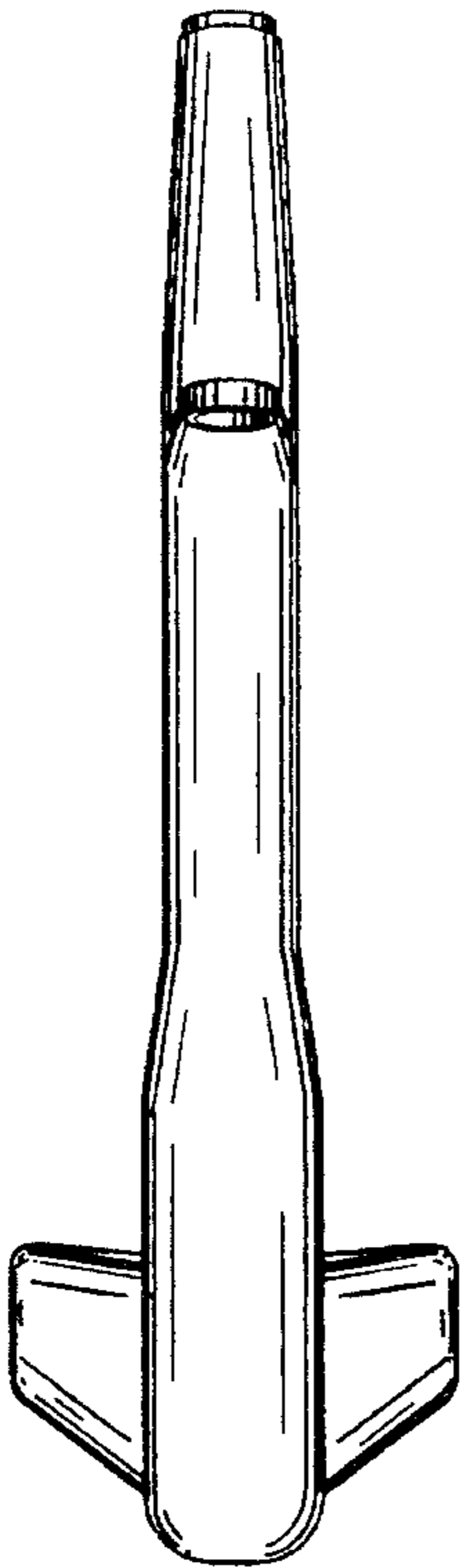

Fig. 5.

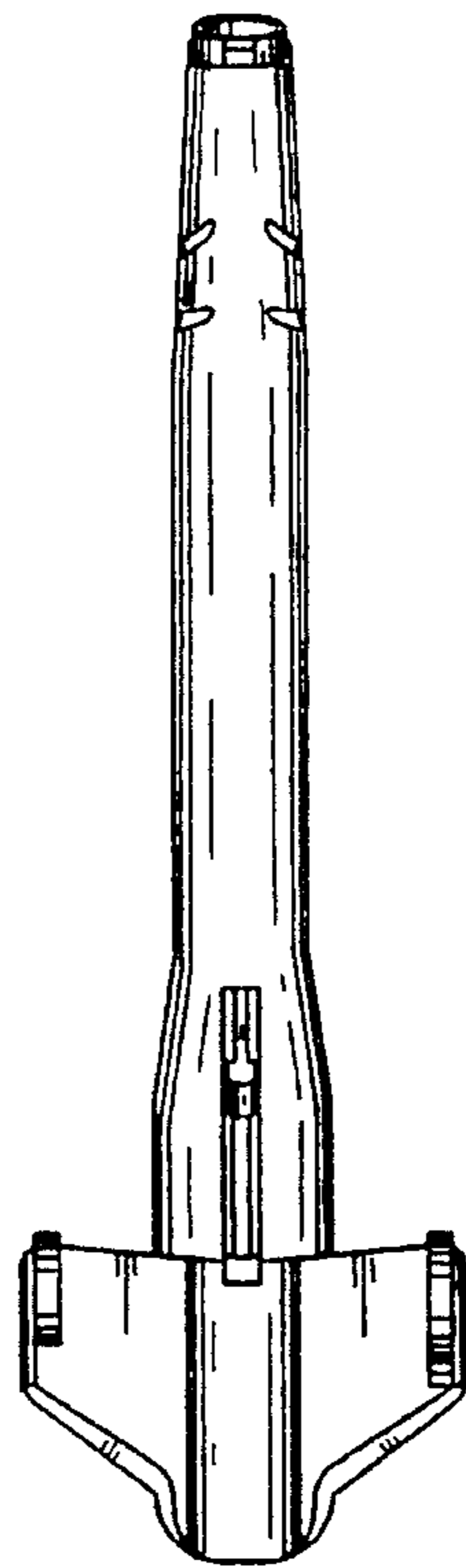

Fig. 6.

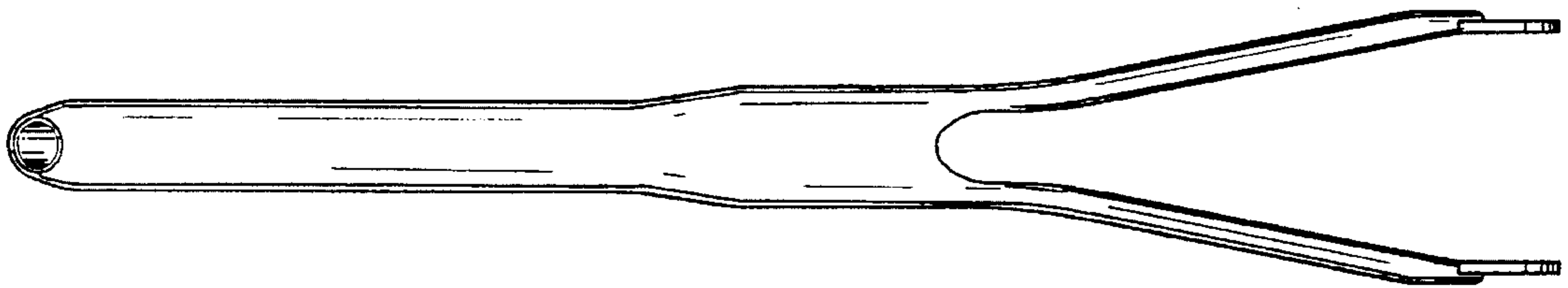

Fig. 7.

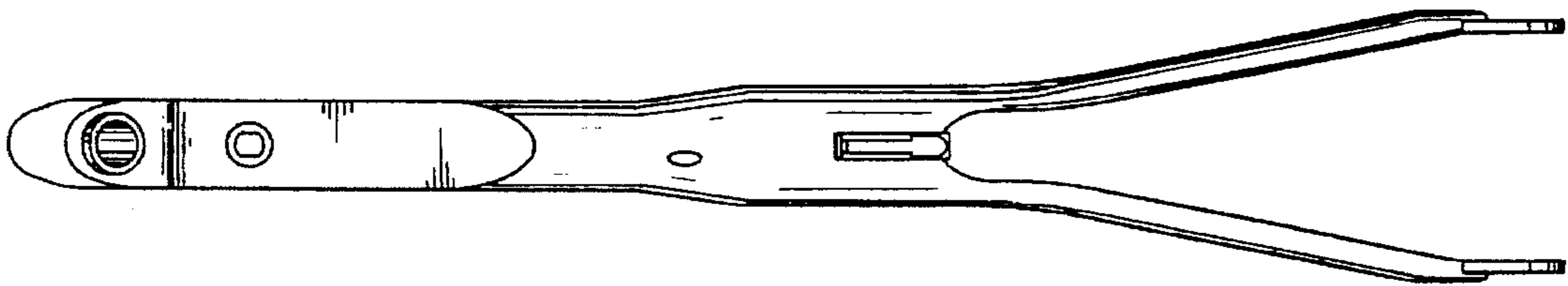

Fig. 8.