



US00D371059S

United States Patent [19] Howe

[11] Patent Number: **Des. 371,059**

[45] Date of Patent: ****Jun. 25, 1996**

[54] **PIPE WELDING FIXTURE**

[75] Inventor: **Nigel Howe**, Taunton, Mass.

[73] Assignee: **Preston-Eastin, Inc.**, Tulsa, Okla.

[**] Term: **14 Years**

[21] Appl. No.: **30,581**

[22] Filed: **Nov. 2, 1994**

[52] U.S. Cl. **D8/72**

[58] Field of Search D8/71, 72; D15/140,
D15/144.2; 81/173, 463; 248/74.1, 74.2,
74.3, 74.4; 269/218, 240, 243, 296

[56] **References Cited**

U.S. PATENT DOCUMENTS

D. 252,995	9/1979	Tiedemann, Jr.	D8/71
D. 307,535	5/1990	Hsu	D8/71
2,995,357	8/1961	Dennis et al.	269/218
4,655,444	4/1987	Wang	269/296

Primary Examiner—Alan P. Douglas

Assistant Examiner—Robert M. Spear
Attorney, Agent, or Firm—Thomas A. Kahrl

[57] **CLAIM**

The ornamental design for pipe welding fixture, as shown and described.

DESCRIPTION

FIG. 1 is a perspective view of a pipe welding fixture showing my new design;

FIG. 2 is a front elevational view thereof;

FIG. 3 is a top plan view thereof;

FIG. 4 is a left side elevational view thereof;

FIG. 5 is a right side elevational view thereof;

FIG. 6 is a bottom plan view thereof; and,

FIG. 7 is a rear elevational view thereof.

The dominant feature of the invention resides in the design of a pipe welding fixture for use with clamping pipe bends and straight pieces of pipe.

The broken line showing of a pipe is for illustrative purposes only and forms no part of the claimed design.

1 Claim, 2 Drawing Sheets

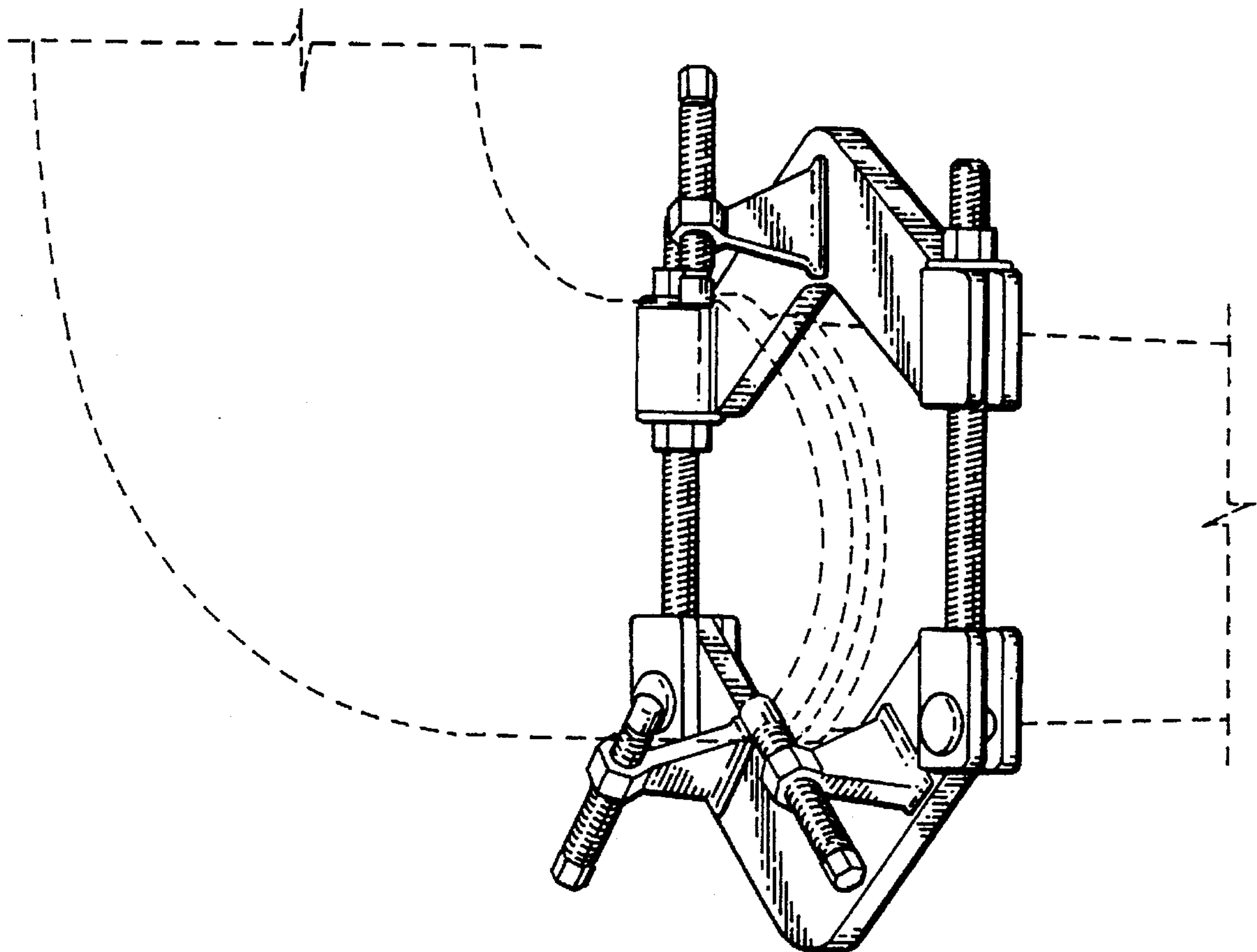

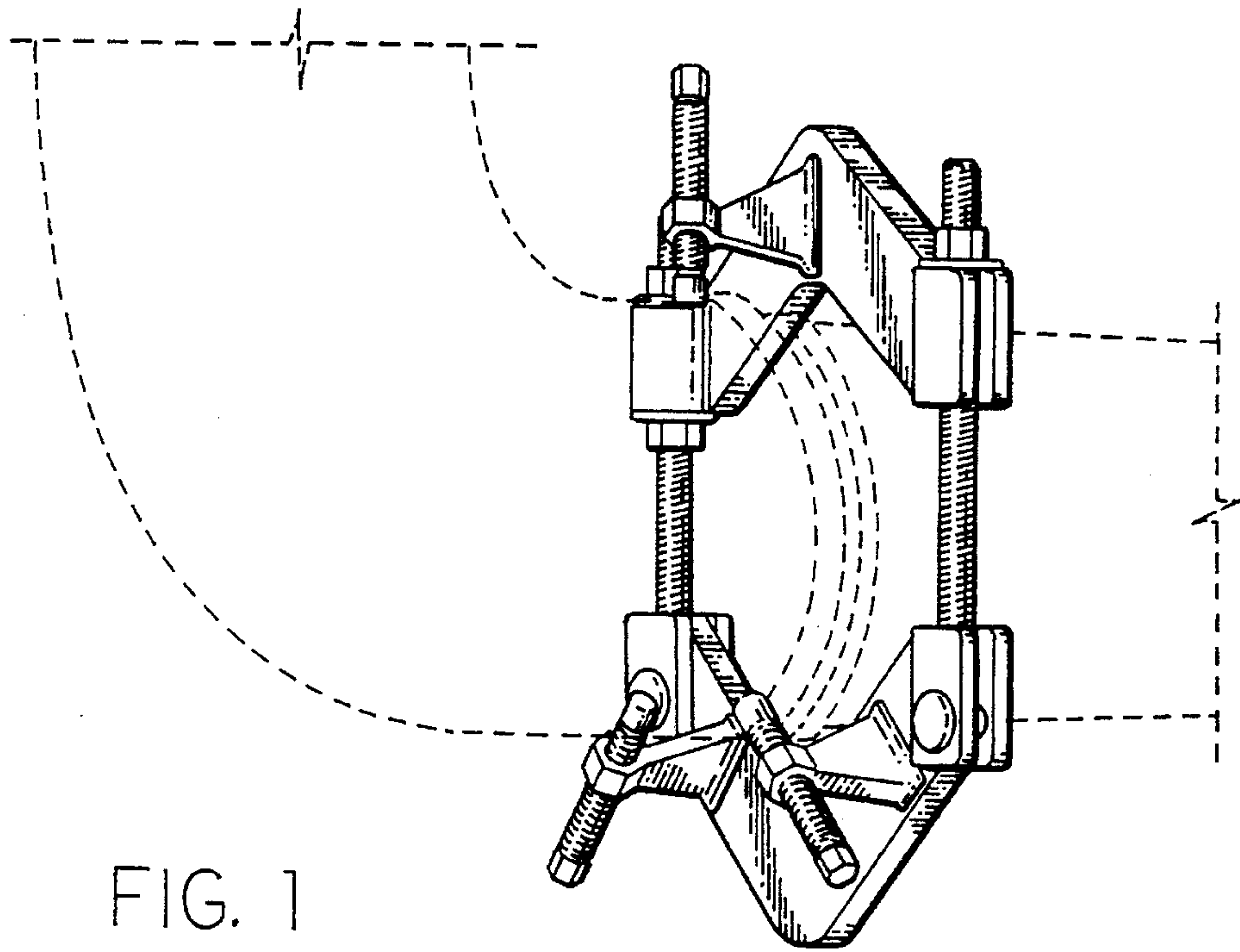

FIG. 1

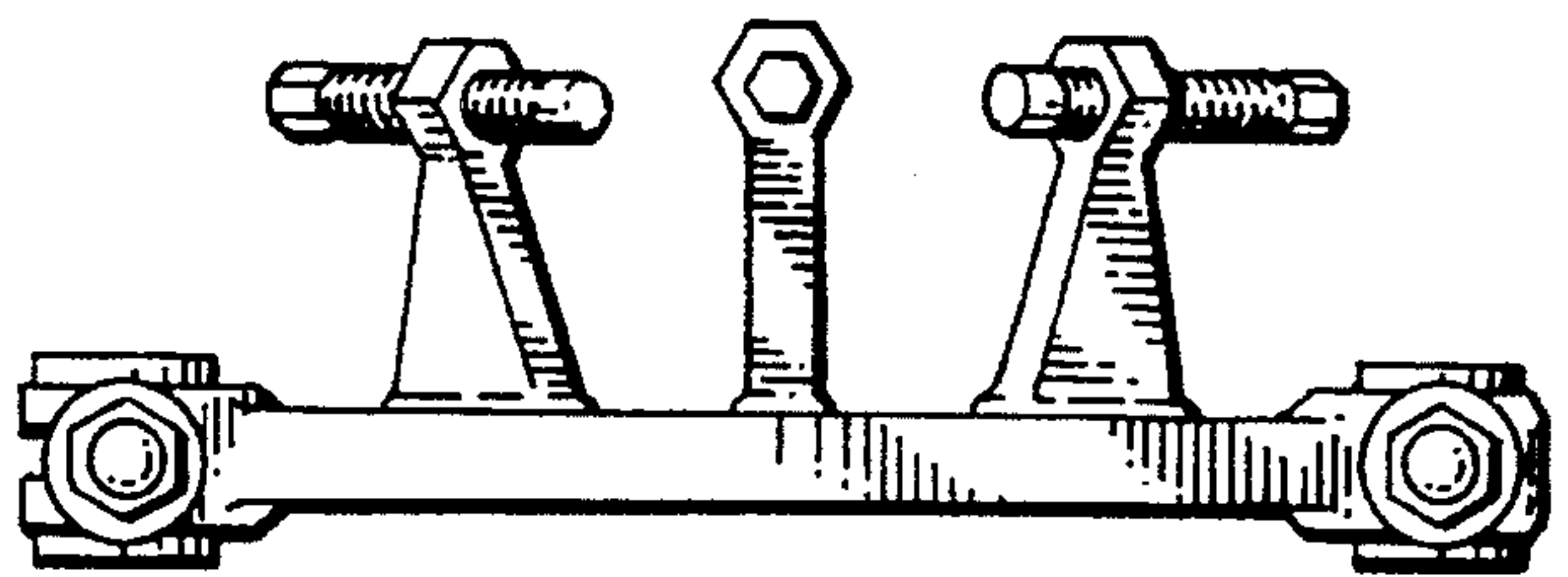

FIG. 2

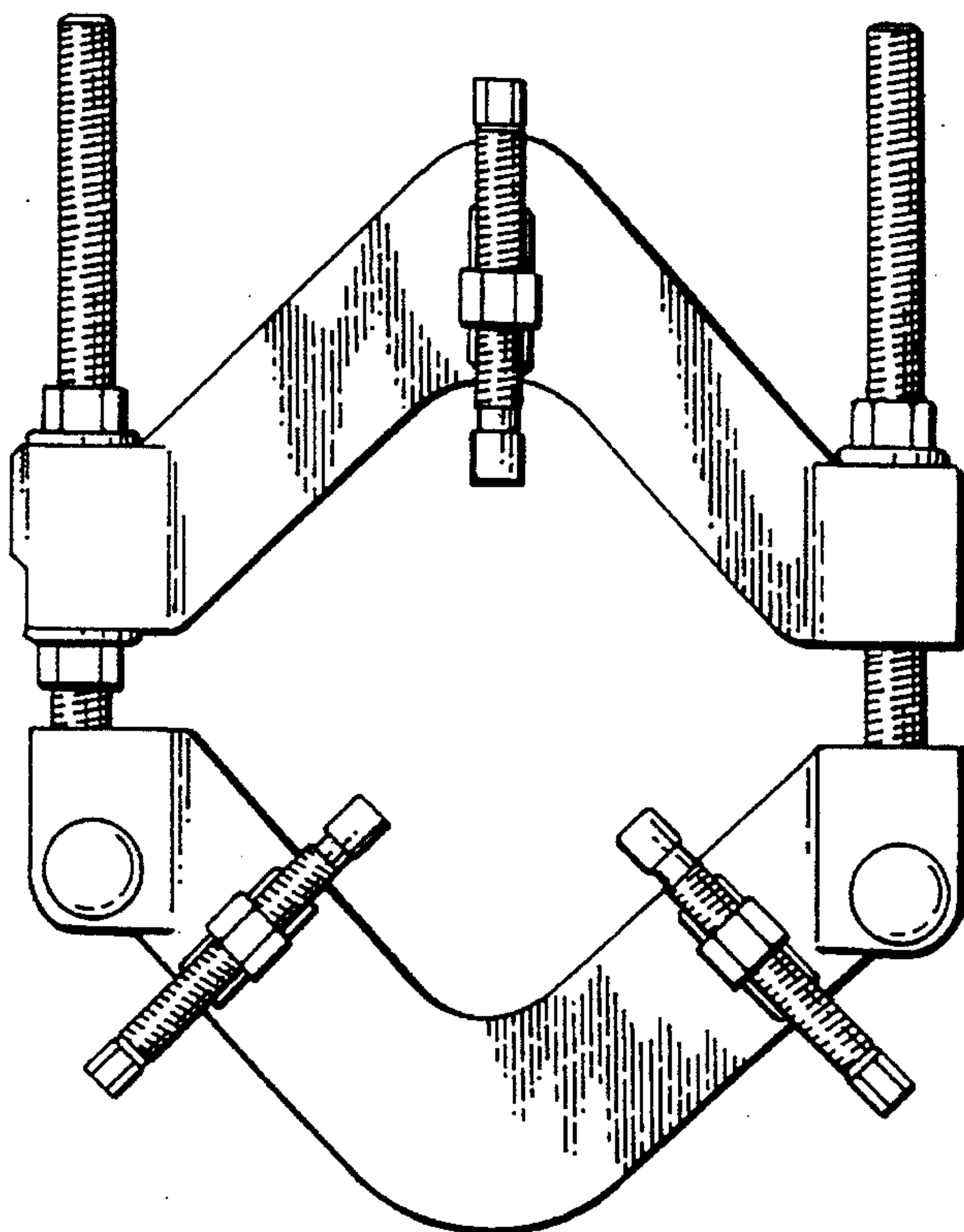

FIG. 3

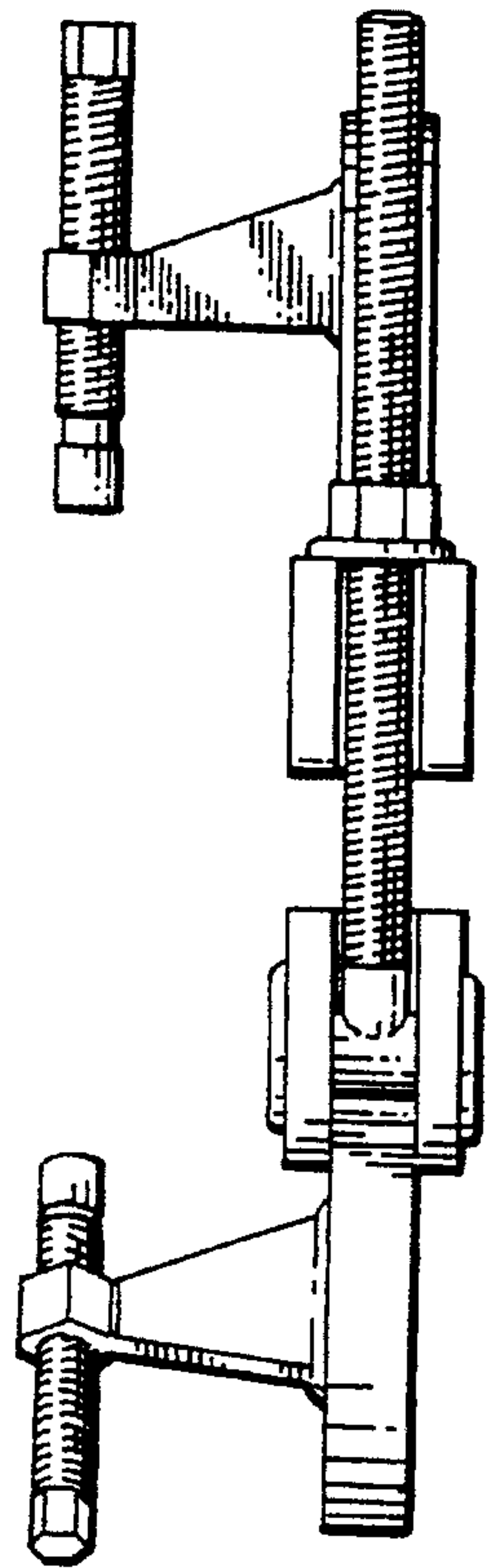

FIG. 4

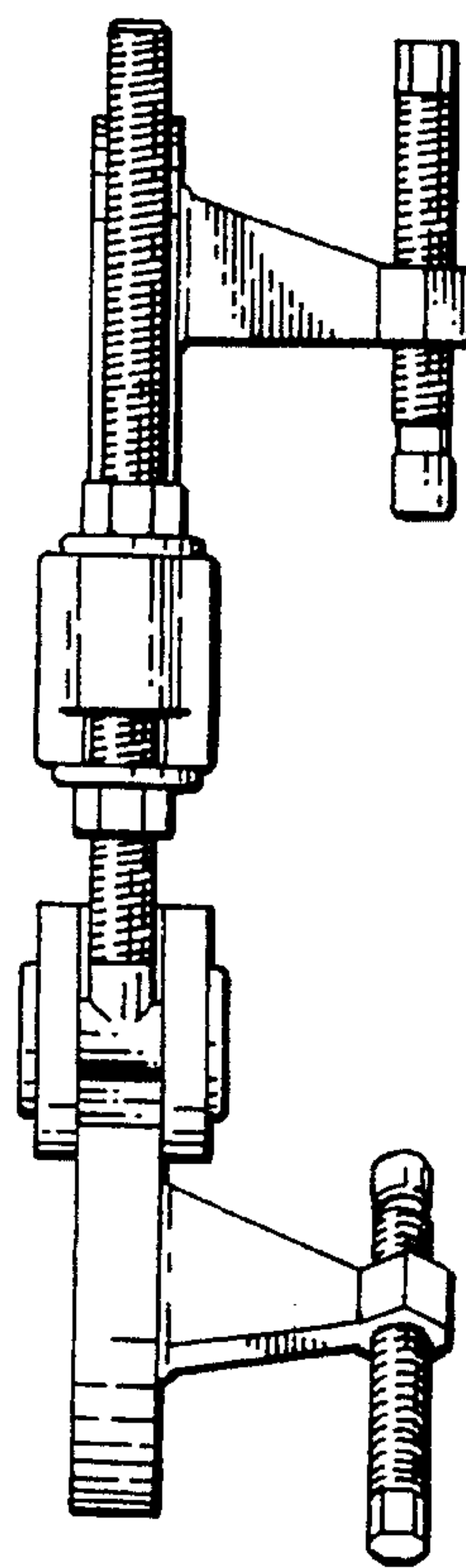

FIG. 5

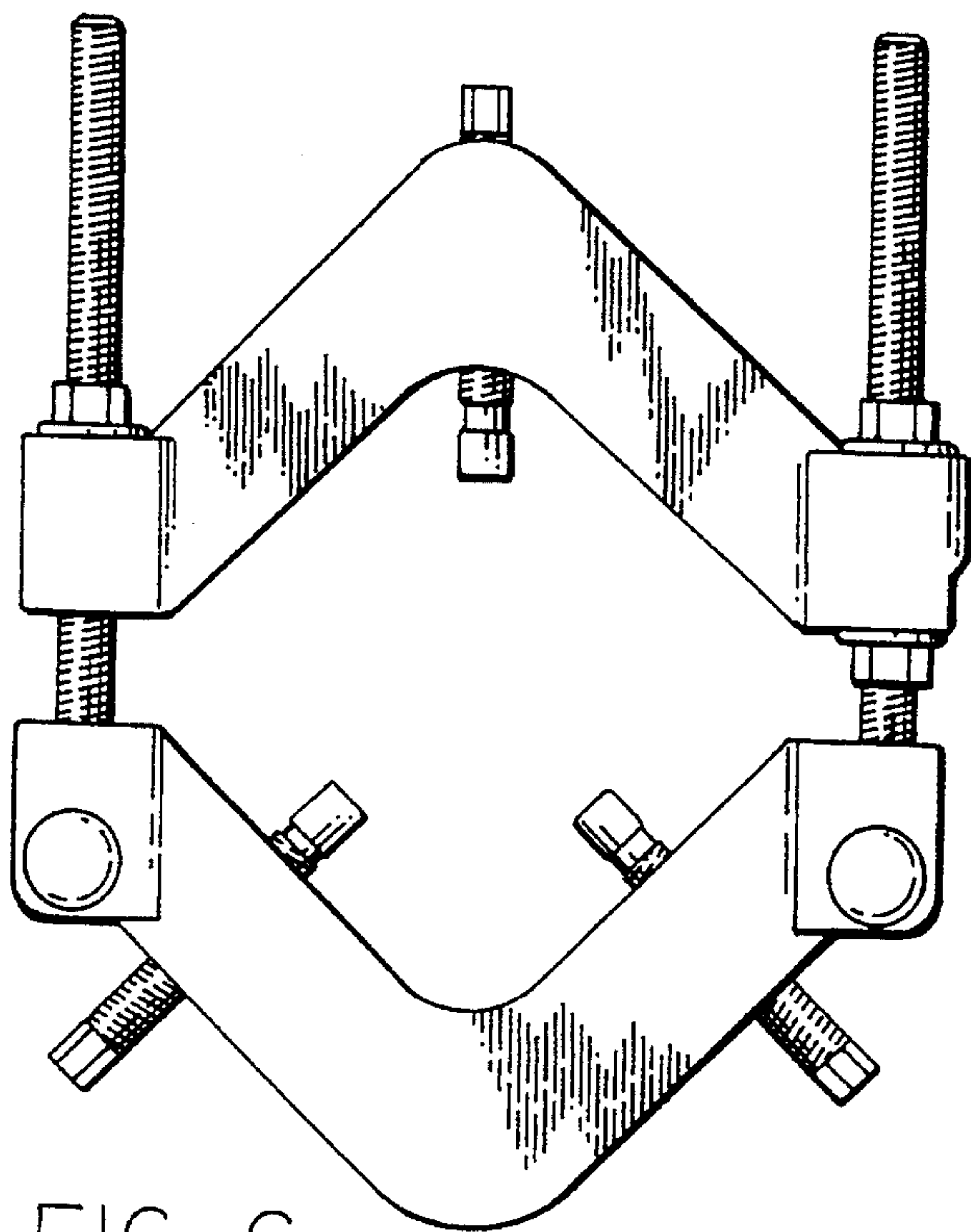

FIG. 6

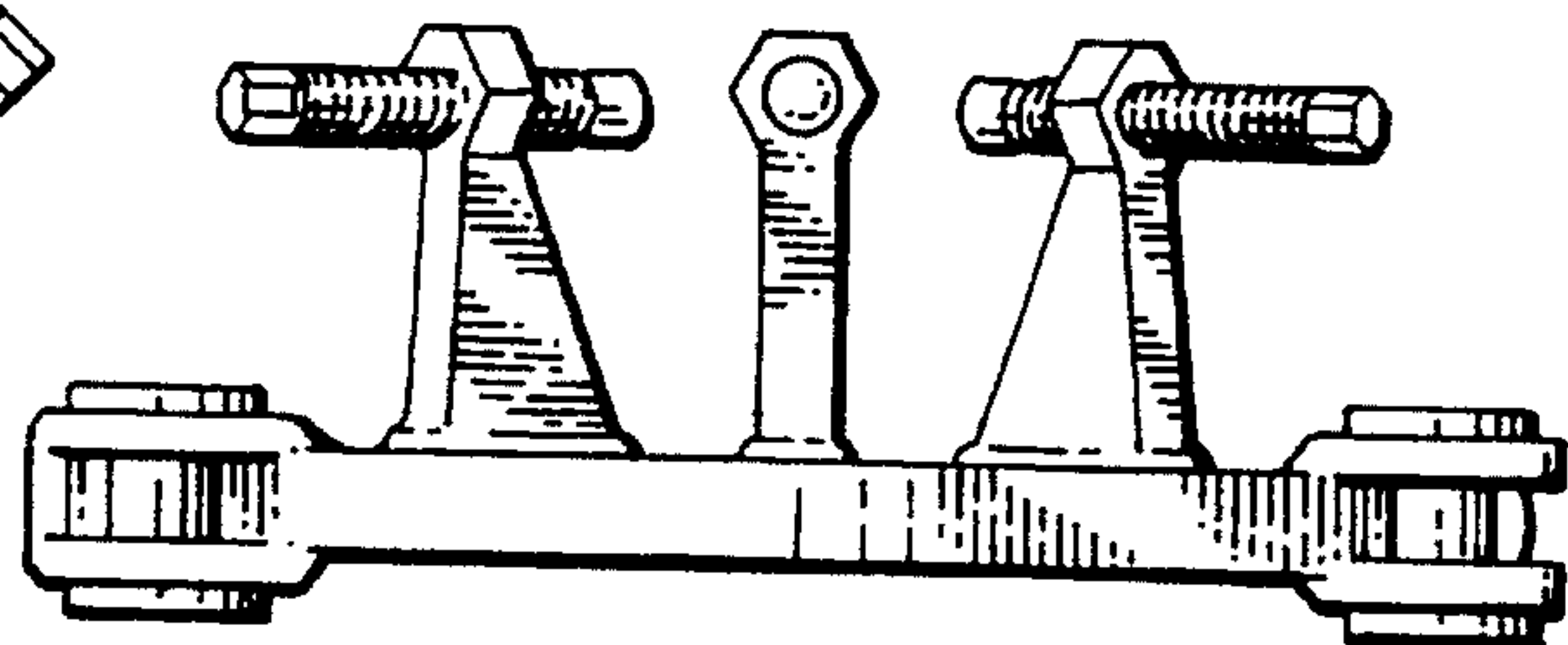

FIG. 7