



US00D370943S

United States Patent [19]

Maxwell et al.

[11] Patent Number: **Des. 370,943**

[45] Date of Patent: ****Jun. 18, 1996**

[54] TOY VEHICLE

5,106,150 4/1992 Litwicki 446/470

[75] Inventors: **Matthew C. Maxwell**, Westerville;
Christopher G. Walter, Suffield, both
of Ohio

[73] Assignee: **The Little Tikes Company**, Hudson,
Ohio

[**] Term: **14 Years**

[21] Appl. No.: **32,731**

[22] Filed: **Dec. 27, 1994**

[52] U.S. Cl. **D21/78**

[58] Field of Search D21/71, 74-80,
D21/129, 130, 132, 134, 135; D12/92,
100; 446/160, 428, 447, 456, 465, 470;
280/87.021, 828, 1.13

[56] **References Cited**

U.S. PATENT DOCUMENTS

D. 111,248	9/1938	Forman .	
D. 211,481	6/1968	Seitzenger et al.	D34/15
D. 236,607	9/1975	Bundschuh et al.	D12/107
D. 242,701	12/1976	Vniegra	D12/80
D. 264,608	5/1982	Manol	D21/78
D. 269,098	5/1983	Manol	D21/78
D. 303,776	10/1989	Aker	D12/108
D. 311,760	10/1990	Harrod	D21/78
D. 322,998	1/1992	Harrod	D21/78
D. 323,193	1/1992	Litwicki	D21/78
D. 338,925	8/1993	Van Huystee	D21/78
D. 347,030	5/1994	Nolan	D21/78
D. 356,285	3/1995	Yang	D12/85

OTHER PUBLICATIONS

P. 25, Toy vehicle; Flexible Flyer, Europe Corporation, address unknown. Publication date 1991.
Catalog page, Toy vehicles; Power Wheels, A Kransco Group Company, 3405 Meyer Rd., P.O. Box 6700, Fort Wayne, Indiana 46896-0700. Publication date 1991.
P. 12, Toy vehicle; Blazon-Flexible Flyer Inc., 100 Tubb Ave., West Point, Mississippi 39773. Publication date 1988.

Primary Examiner—Terry A. Wallace
Assistant Examiner—R. Barkai
Attorney, Agent, or Firm—Richard B. O’Planick; Lisa B. Riedesel

[57] **CLAIM**

The ornamental design for a toy vehicle, as shown and described.

DESCRIPTION

FIG. 1 is a top right front perspective view of a toy vehicle showing our new design;
FIG. 2 is a top plan view thereof;
FIG. 3 is a right side elevational view thereof;
FIG. 4 is a bottom plan view thereof;
FIG. 5 is a left side elevational view thereof;
FIG. 6 is a front elevational view thereof; and,
FIG. 7 is a rear elevational view thereof.
The broken lines are for illustrative purposes only and form no part of the claimed design.

1 Claim, 4 Drawing Sheets

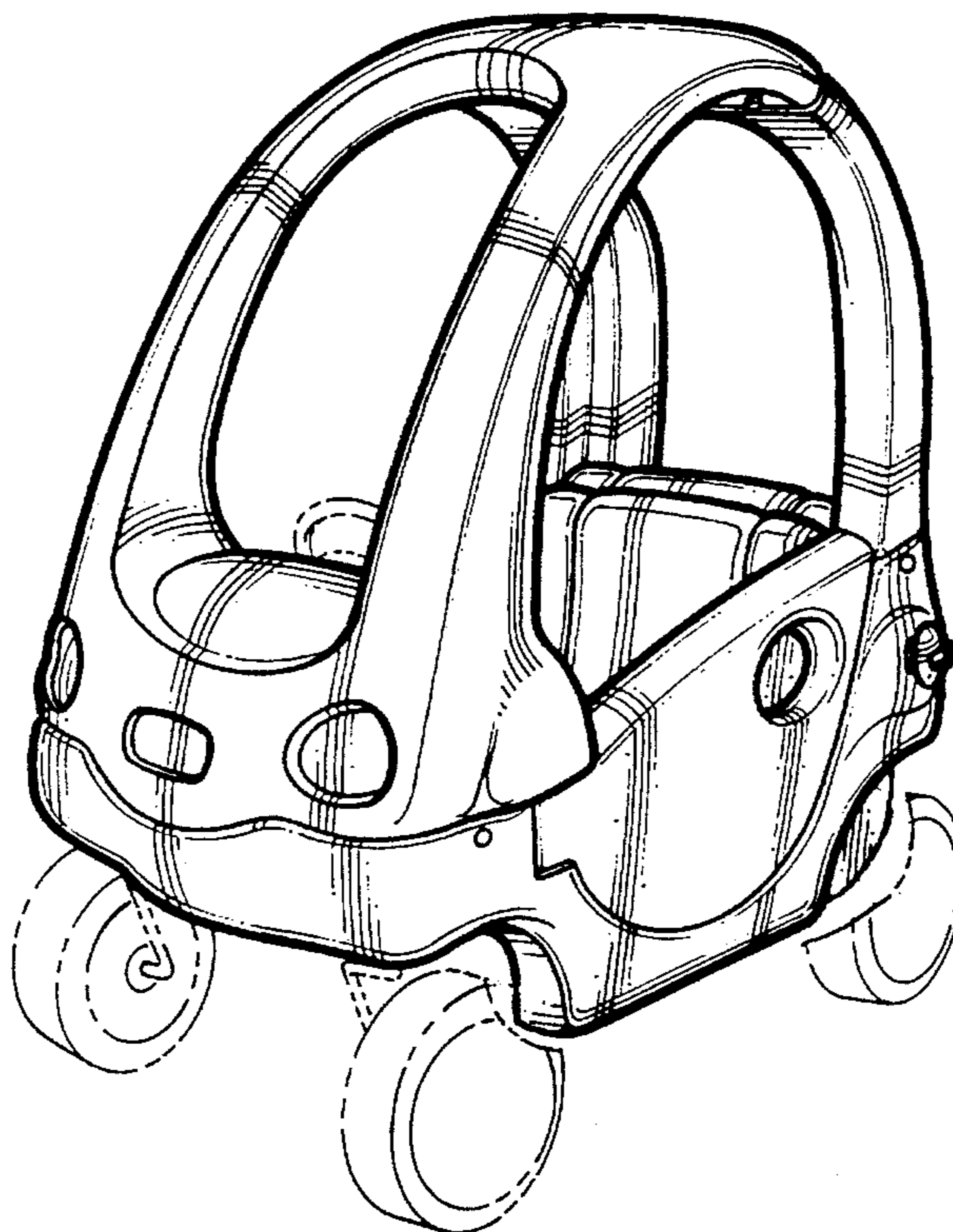

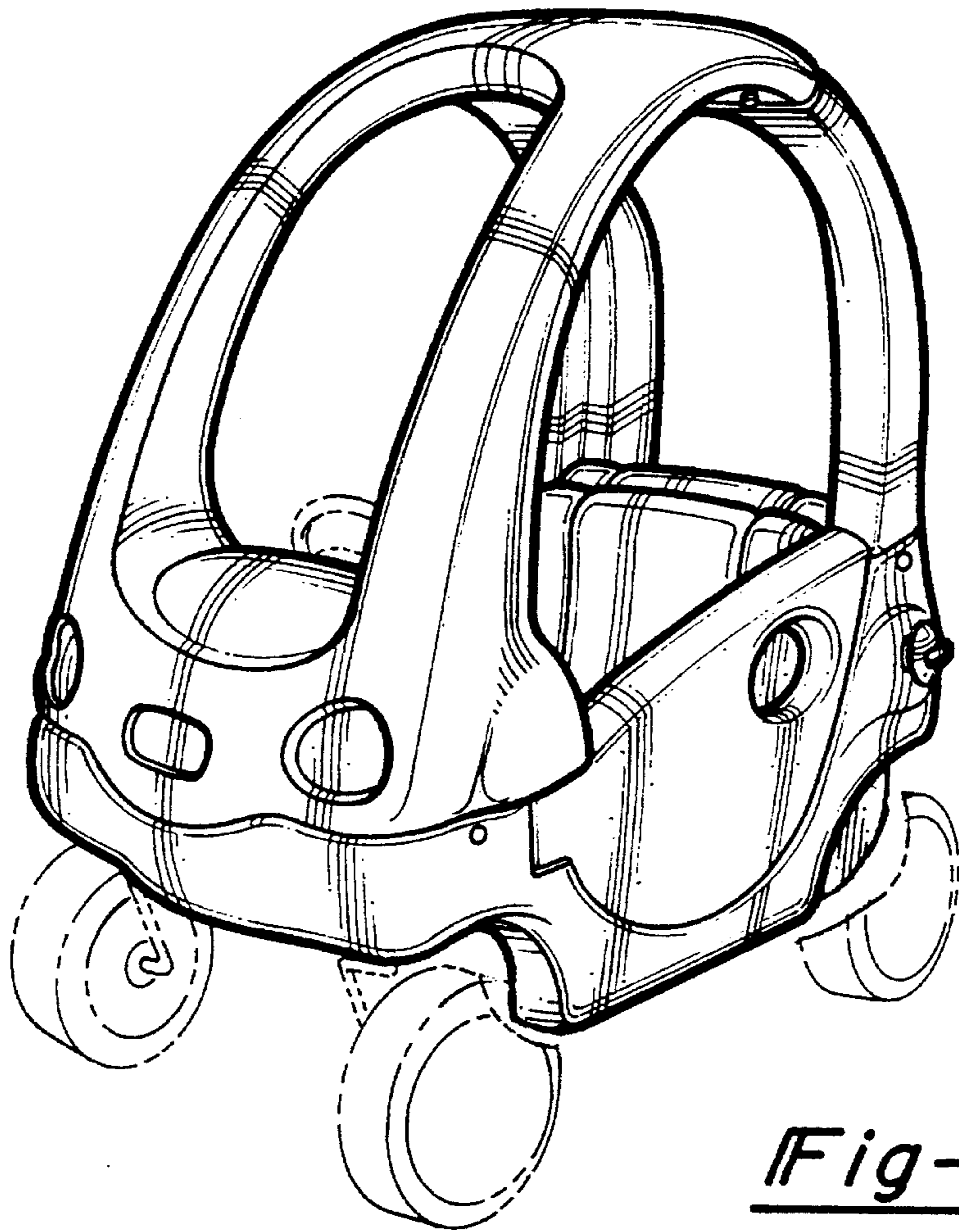
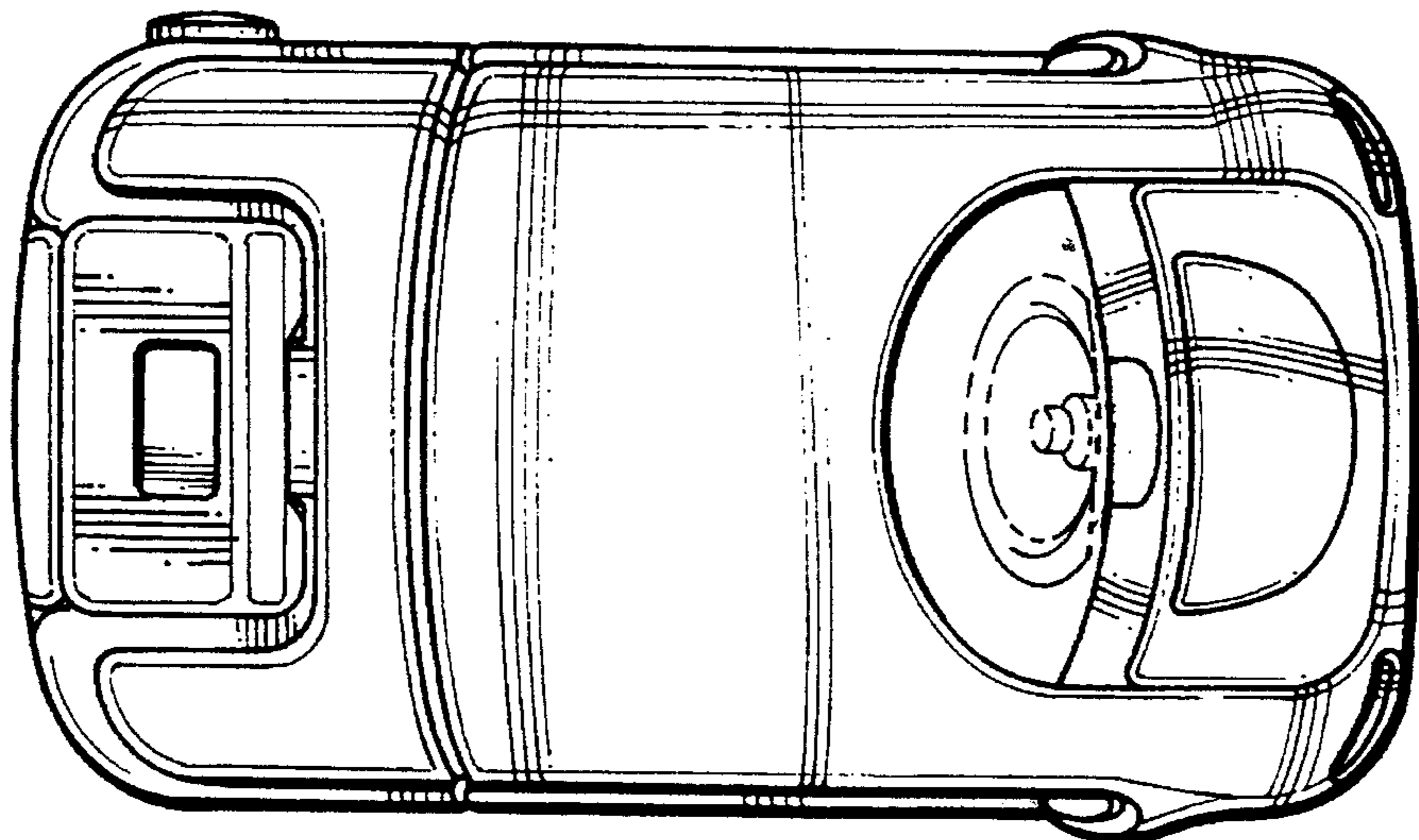

Fig-1

Fig-2



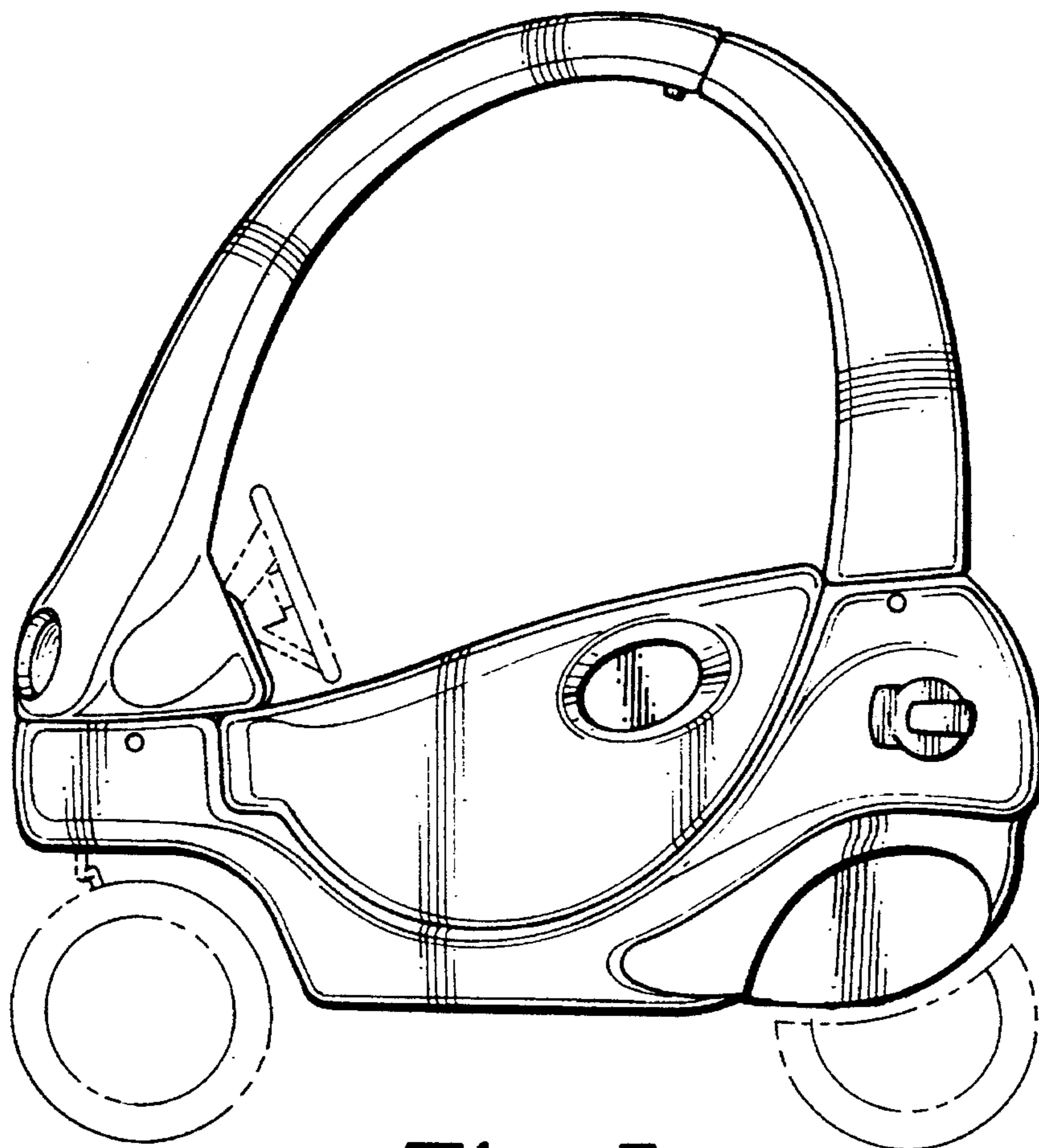
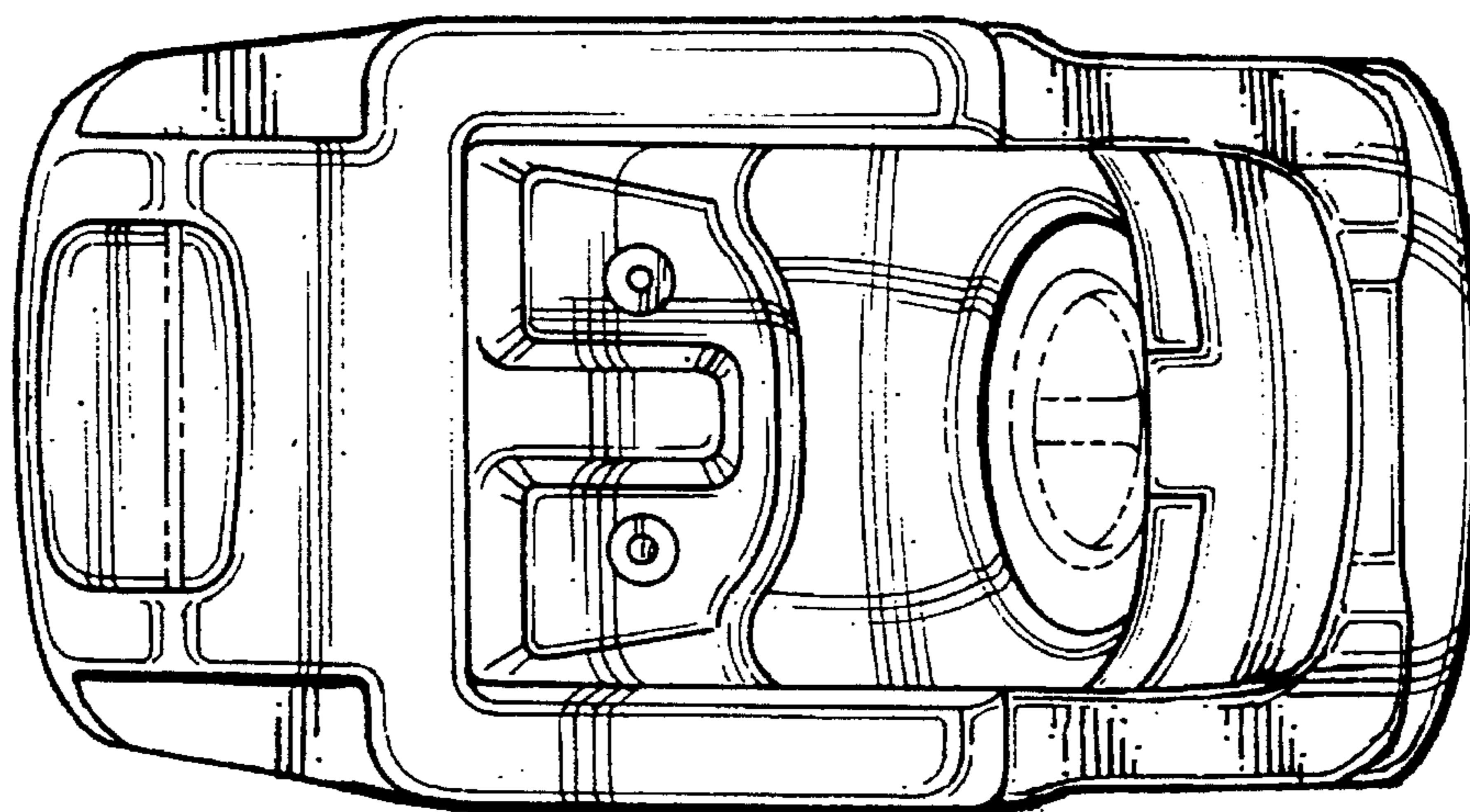

Fig-3

Fig-4



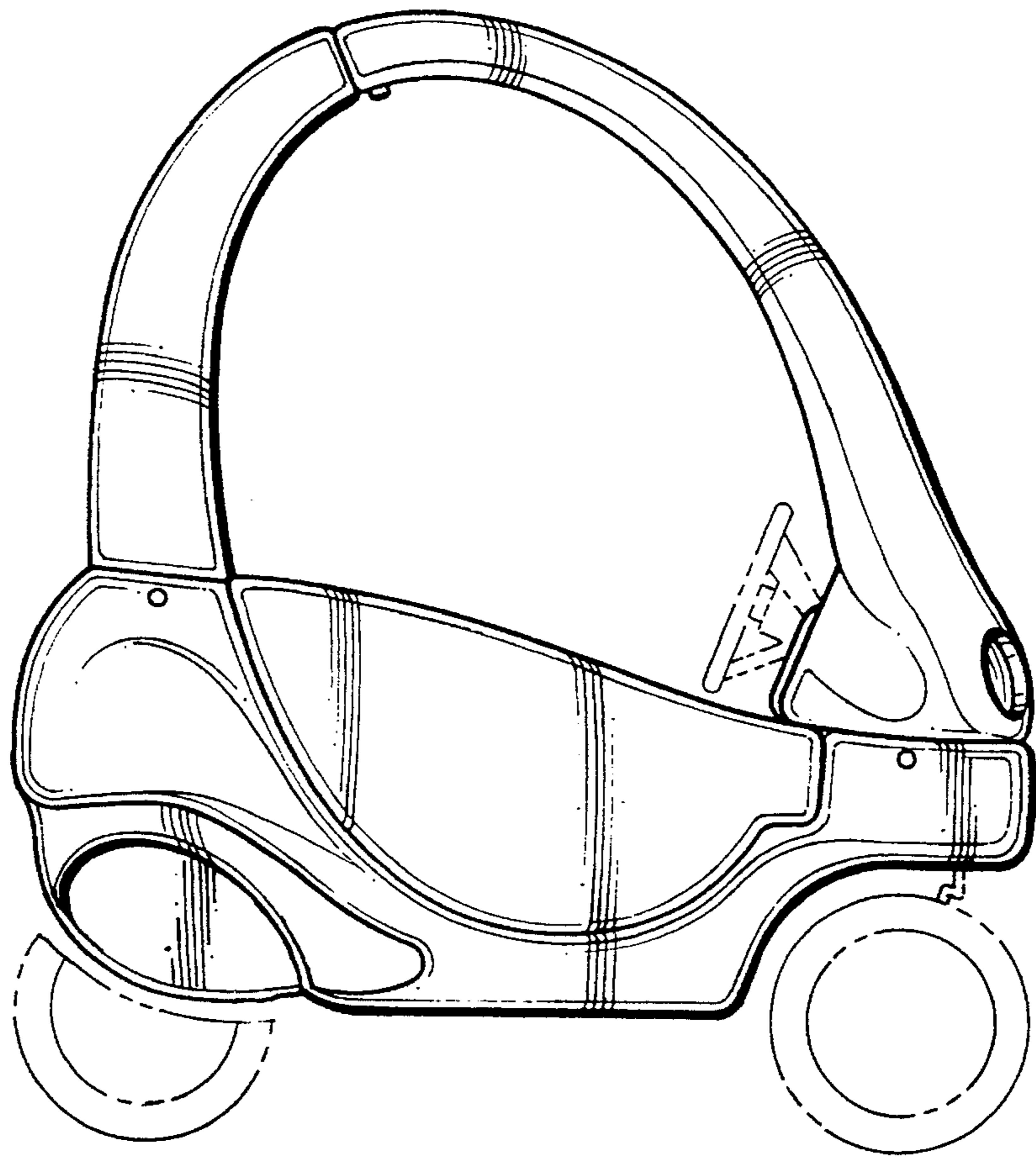

Fig-5

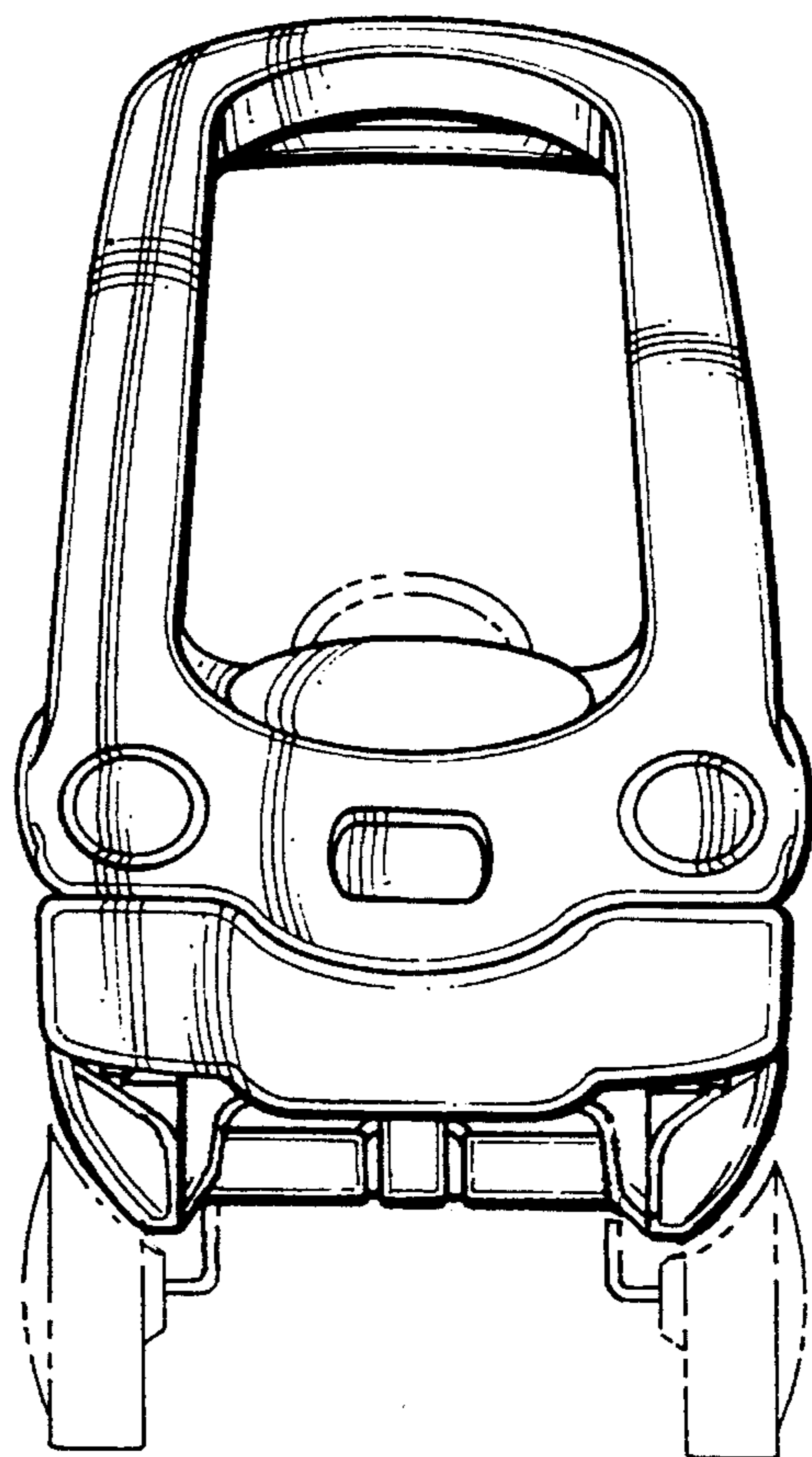

Fig-6

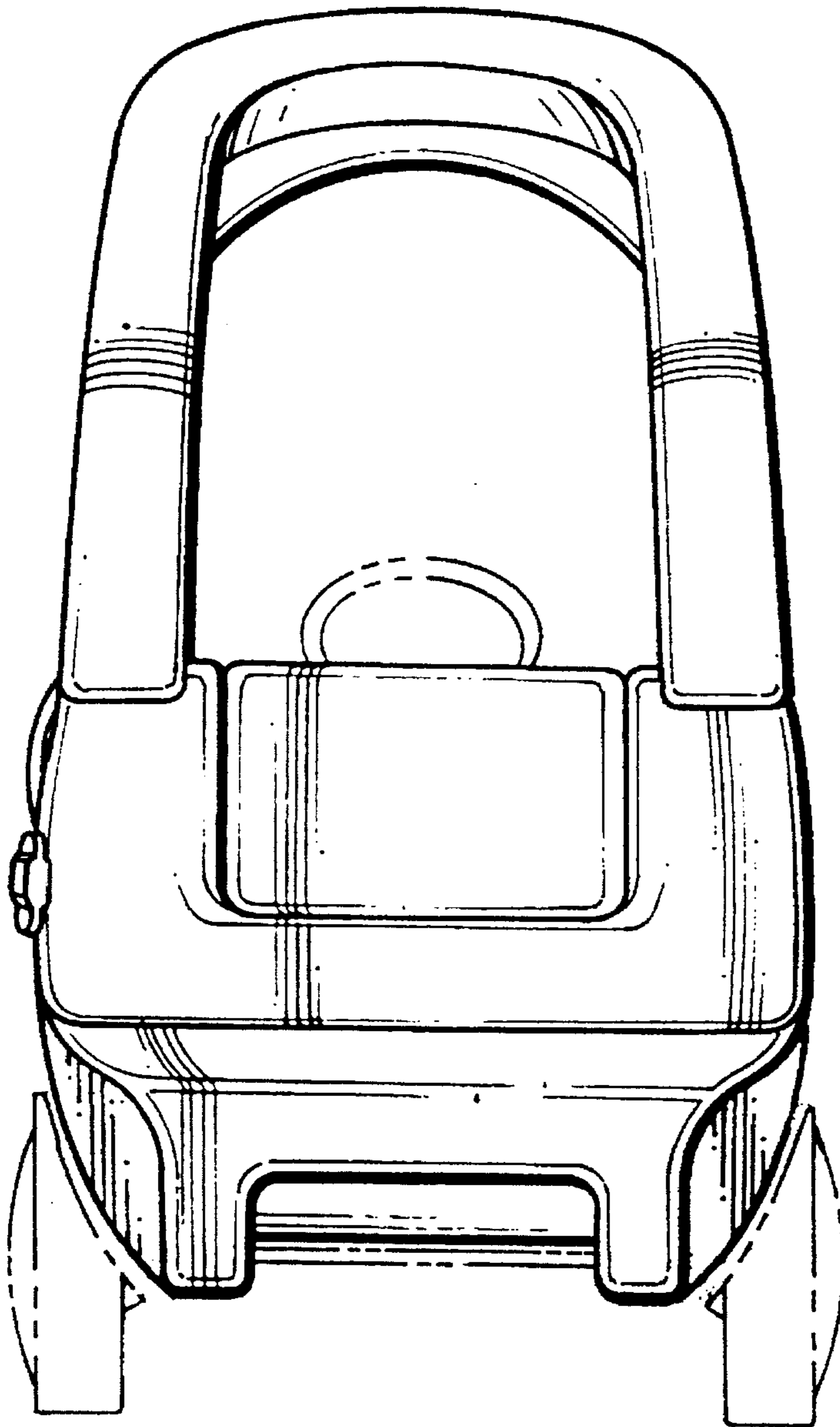

Fig-7