



US00D370876S

United States Patent [19]

Santoro et al.

[11] Patent Number: **Des. 370,876**

[45] Date of Patent: ****Jun. 18, 1996**

[54] **AUTOMOBILE BODY**

[75] Inventors: **Michael Santoro**, Birmingham;
William A. Dayton, Northville; **John E. Herlitz**, Farmington Hills; **Darrel L. Morley**, Troy, all of Mich.

[73] Assignee: **Chrysler Corporation**, Auburn Hills, Mich.

[**] Term: **14 Years**

[21] Appl. No.: **15,838**

[22] Filed: **Nov. 30, 1993**

[52] U.S. Cl. **D12/92**

[58] Field of Search D12/82-3, 86,
D12/88-92; D21/78; 296/185-6

[56] **References Cited**

U.S. PATENT DOCUMENTS

- D. 347,201 5/1994 Kaku et al. D12/92
- D. 347,805 6/1994 Ueno et al. D12/92

OTHER PUBLICATIONS

- Road and Track, Oldsmobile 88 Royale LS, May 1992, p. 74.
- Car and Driver, Concorde, Intrepid, Vision, May 1992, p. 67.
- Car and Driver, Mitsubishi Galant, Aug. 1992, p. 27.
- Car and Driver, Cadillac, middle of page, Mar. 1993, p. 76.
- Car and Driver, Buick Park Avenue, Jul. 1991, p. 146.
- Car and Driver, Pontiac Bonneville SE, Oct. 1991, p. 61.
- Car and Driver, Chrysler Concorde advertisement, Jan. 1993, pp. 8-9.

Primary Examiner—M. H. Tung
Attorney, Agent, or Firm—Mark P. Calcaterra

[57] **CLAIM**

The ornamental design for an automobile body, as shown and described.

DESCRIPTION

FIG. 1 is a front, side perspective view of an automobile body;
 FIG. 2 is a rear, side perspective view thereof;
 FIG. 3 is a side elevational view thereof, the opposite side is a mirror image except that the gas tank cover is not shown;
 FIG. 4 is a front view thereof;
 FIG. 5 is a rear view thereof;
 FIG. 6 is a front, side perspective view of a second embodiment thereof;
 FIG. 7 is a rear, side perspective view thereof, the rear, opposite side view is a mirror image except that the gas tank cover is not shown;
 FIG. 8 is a front view thereof;
 FIG. 9 is a rear view thereof;
 FIG. 10 is front, side perspective view of a third embodiment thereof;
 FIG. 11 is a rear, side perspective view thereof, the rear, opposite side view is a mirror image except that the gas tank cover is not shown;
 FIG. 12 is a front perspective view thereof; and,
 FIG. 13 is a rear perspective view thereof.

The broken line showing drawings of tires and wheels in all views is for illustrative purposes only and form no part of the claimed design. Further, the roof of the automobile body is plain and unornamented.

1 Claim, 10 Drawing Sheets

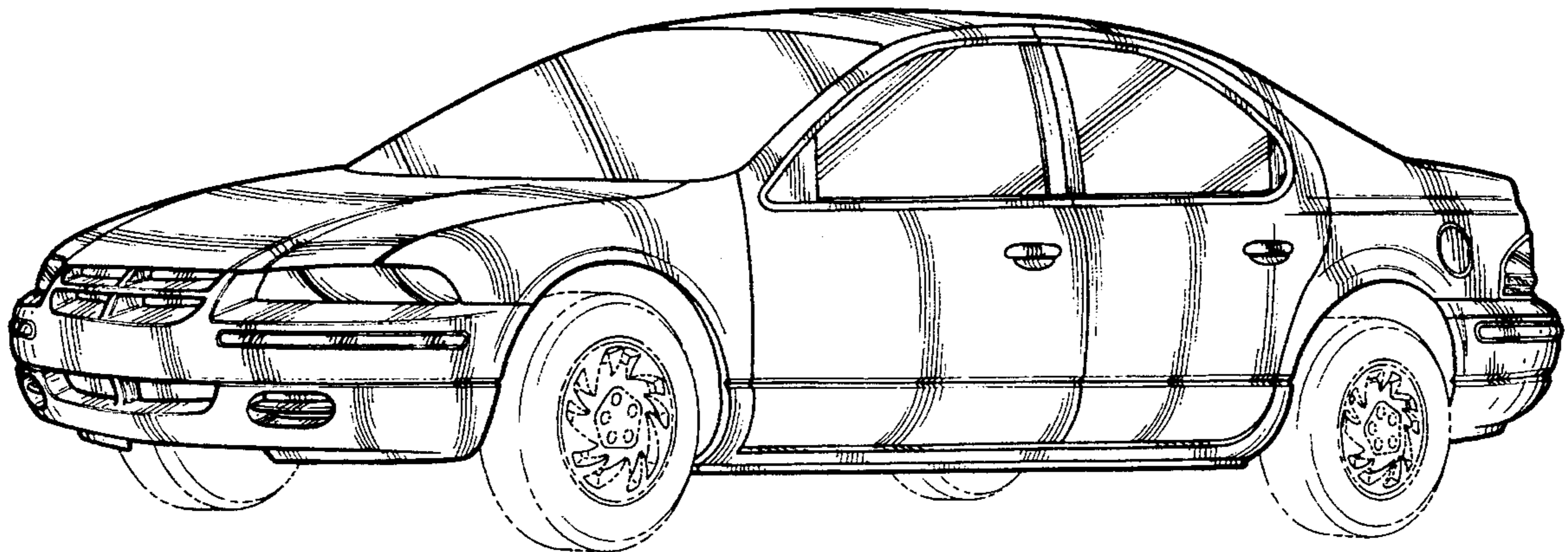

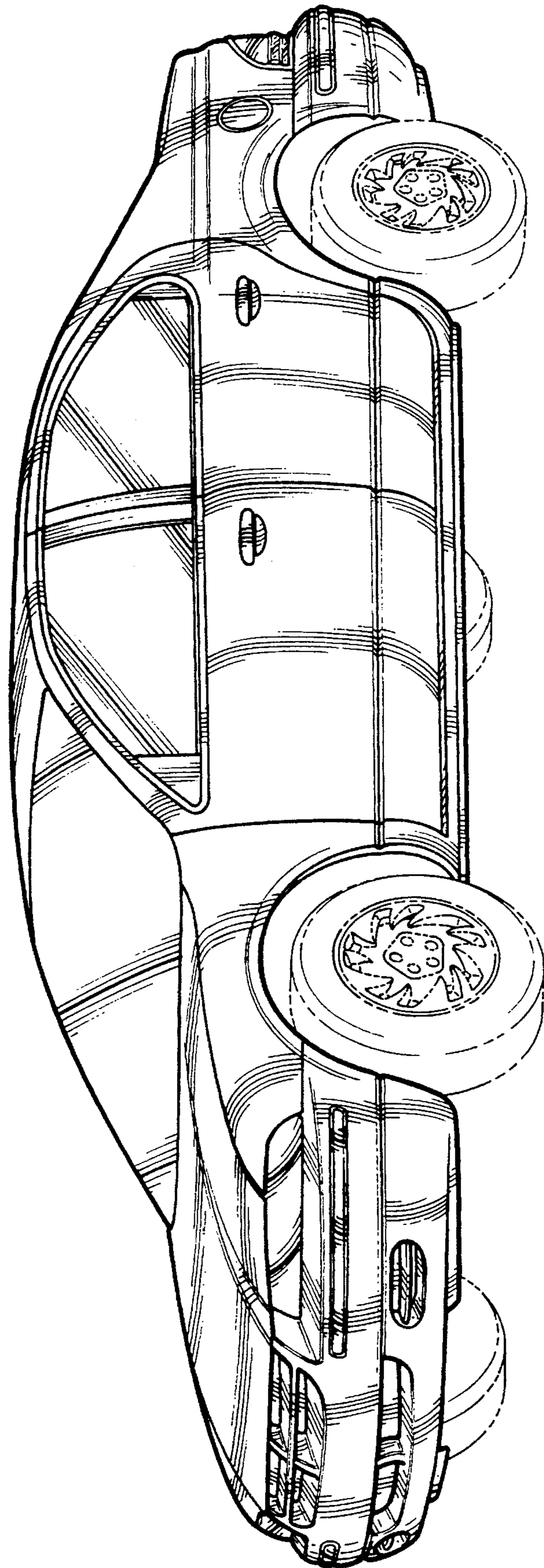

Fig - 1

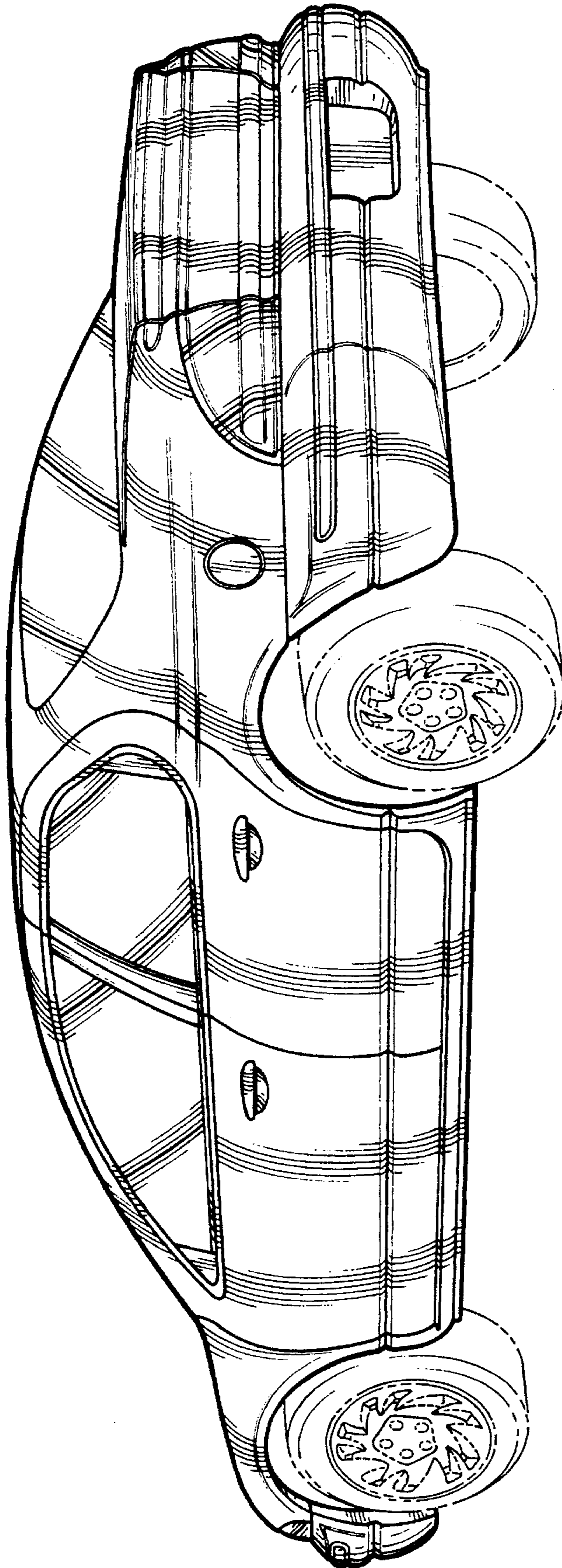

Fig-2

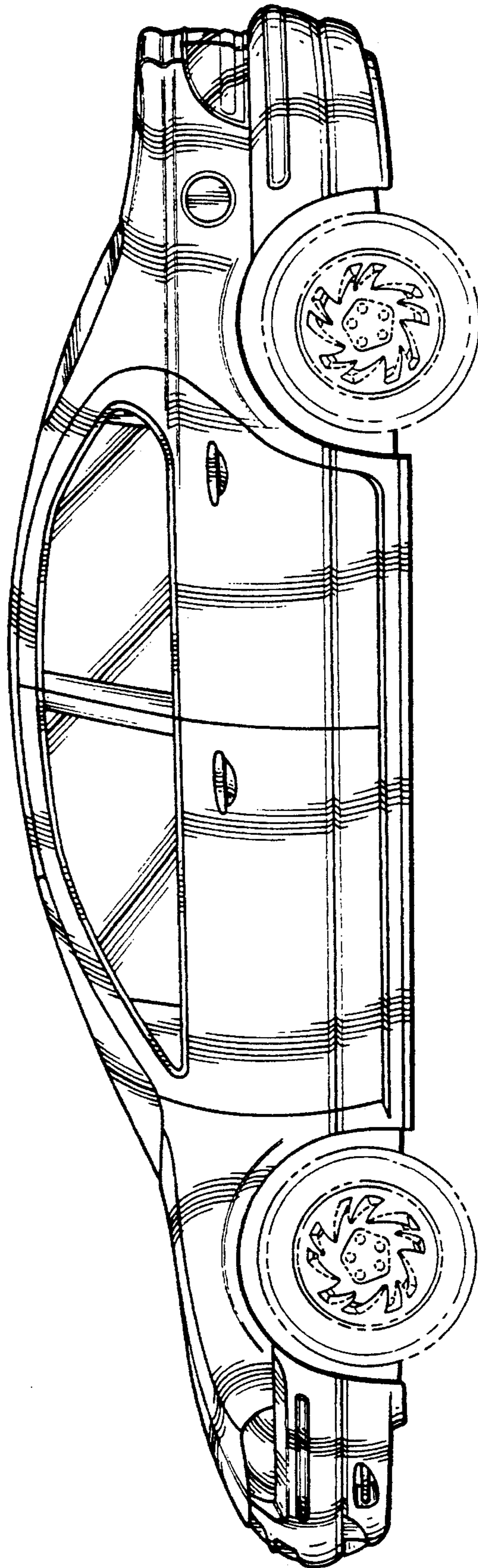

Fig - 3

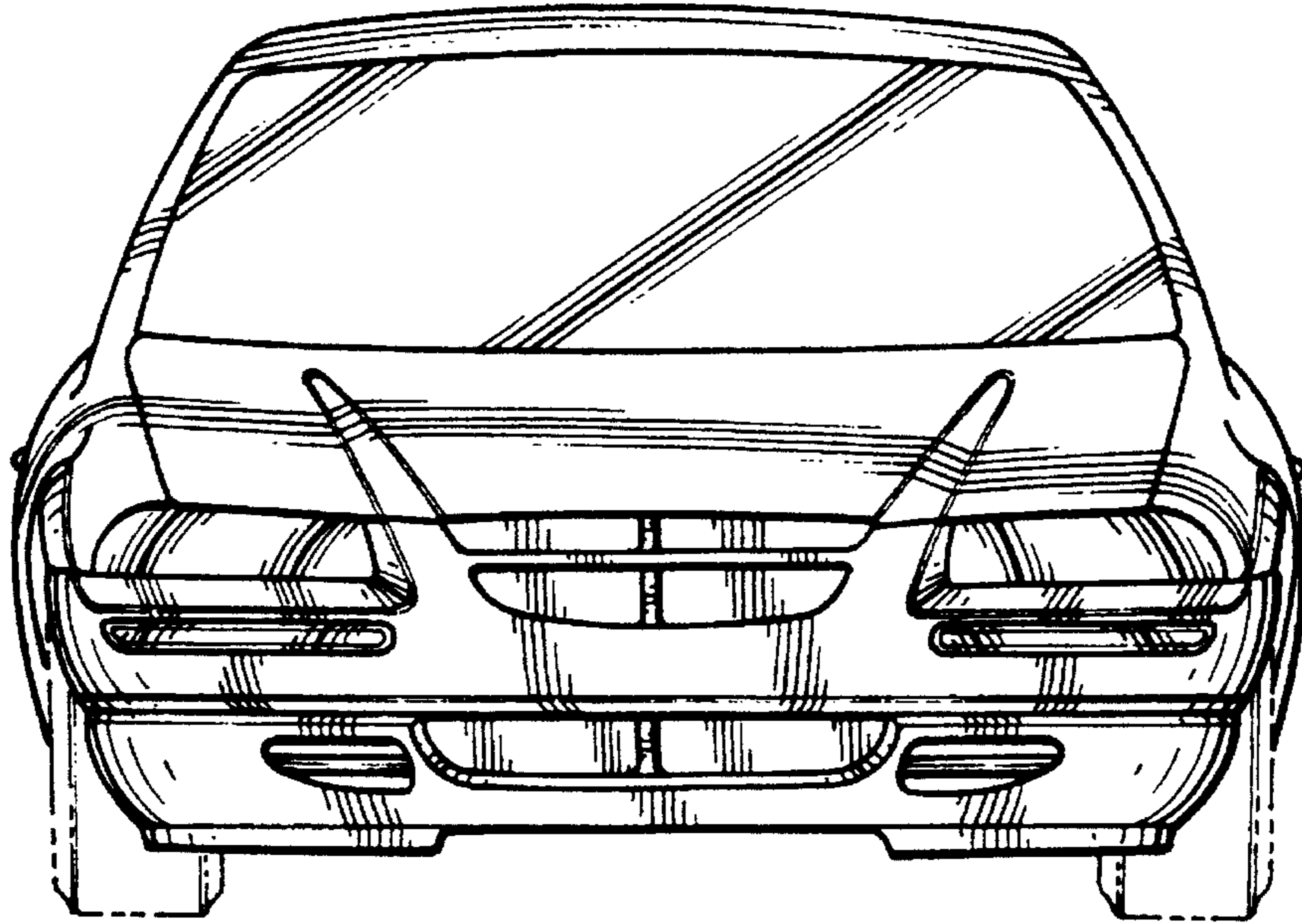

Fig - 4

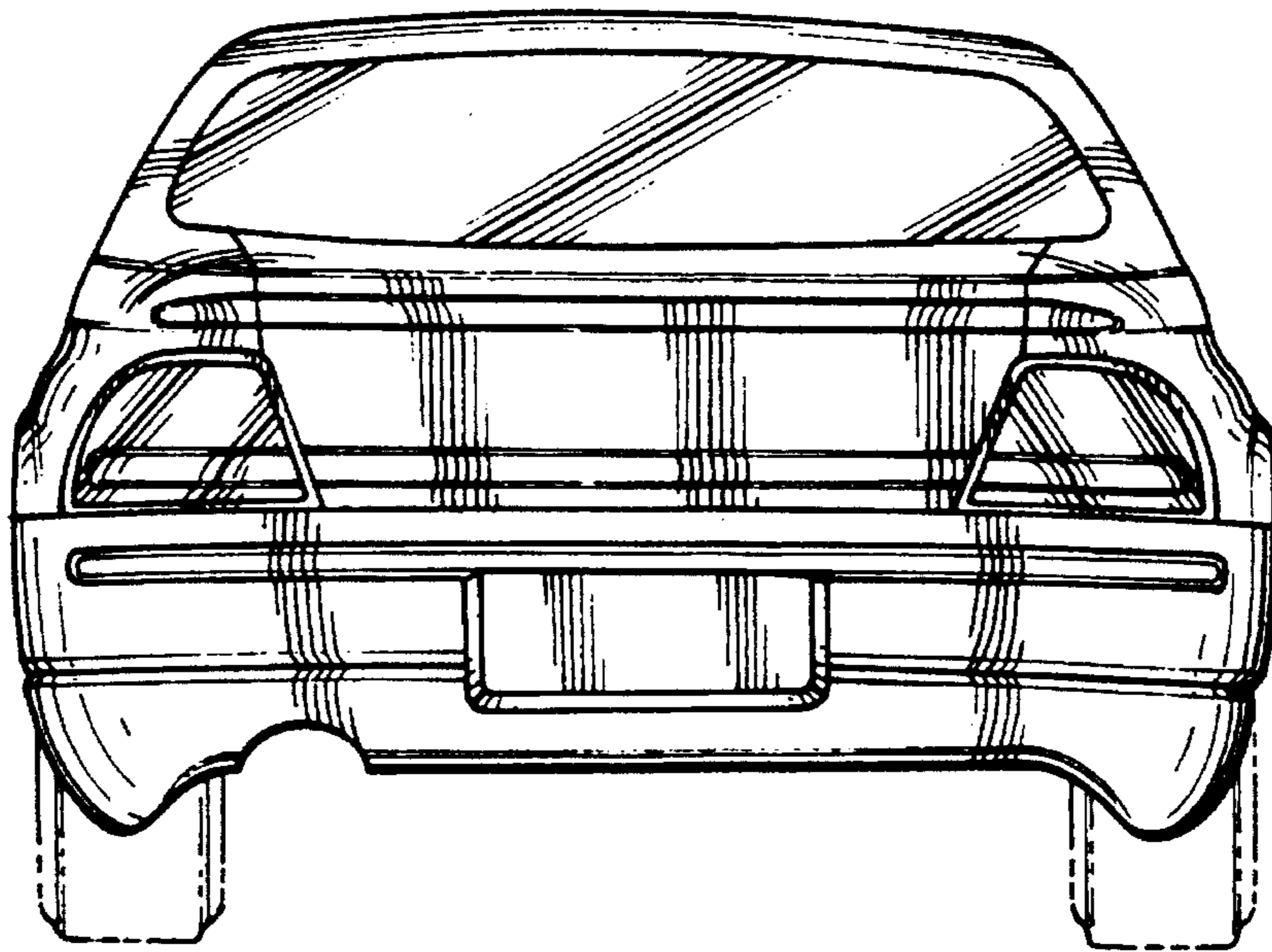

Fig - 5

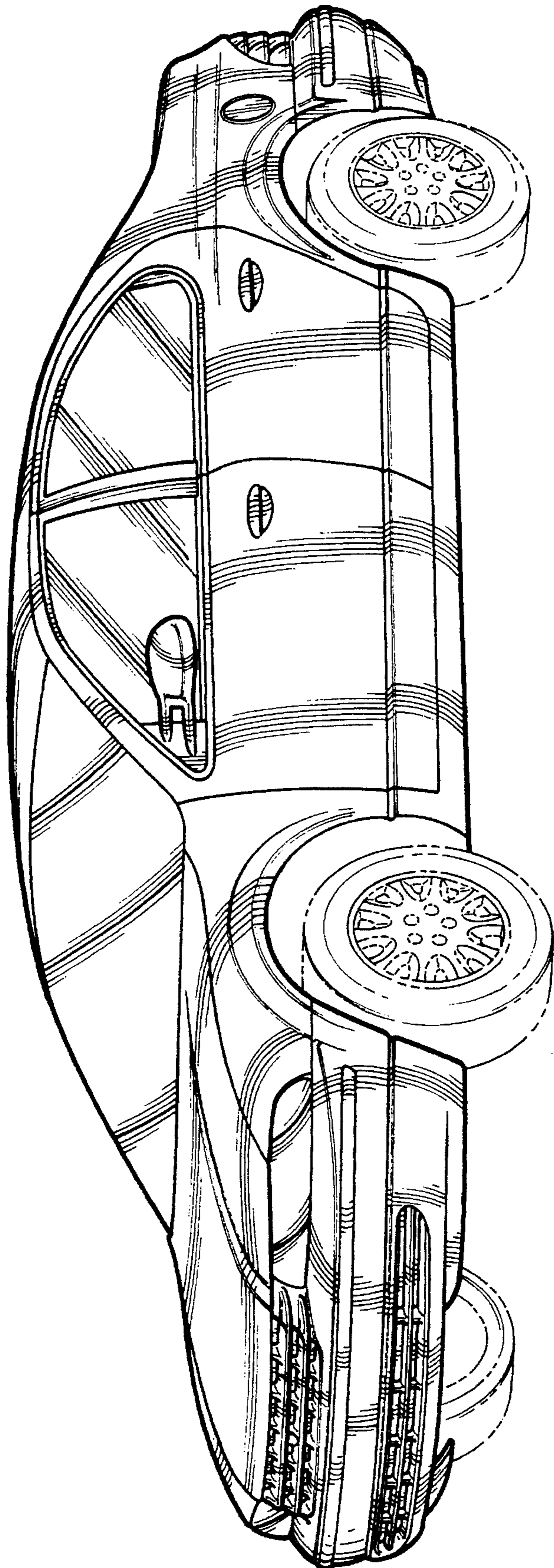

Fig - 6

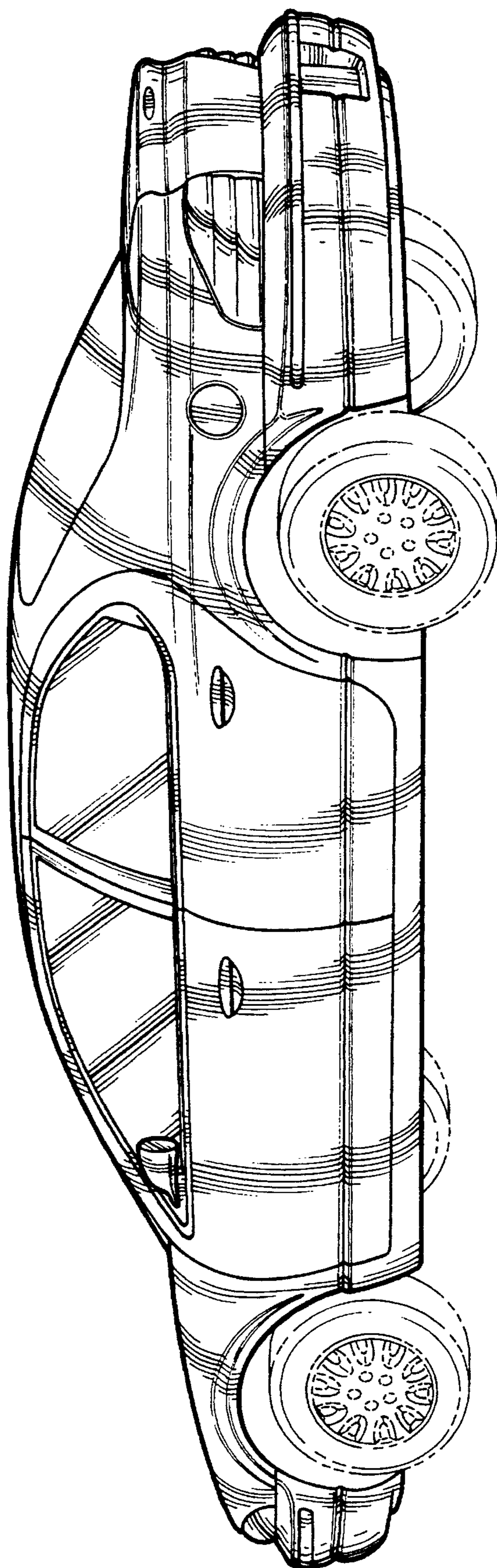

Fig - 7

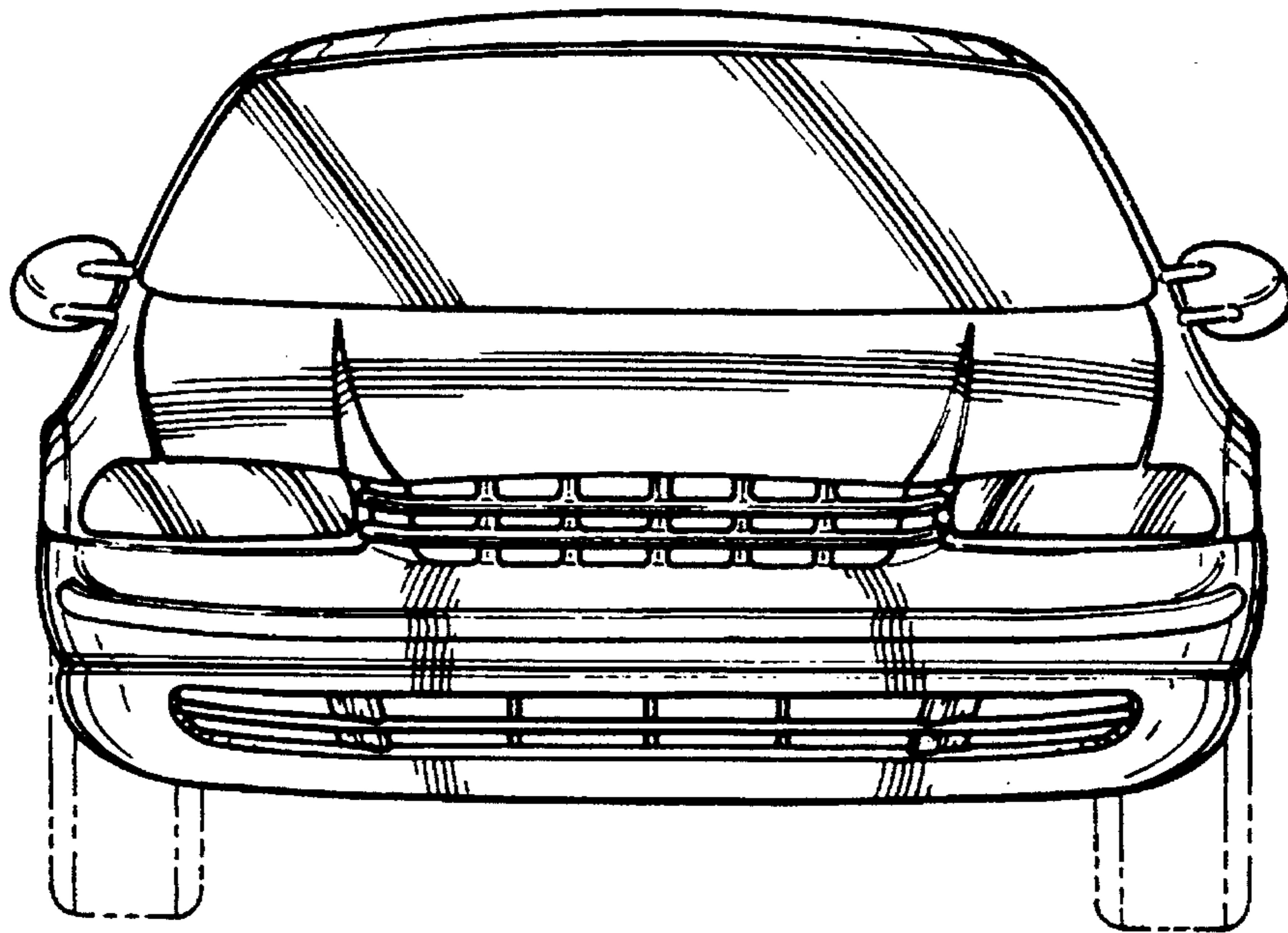

Fig - 8

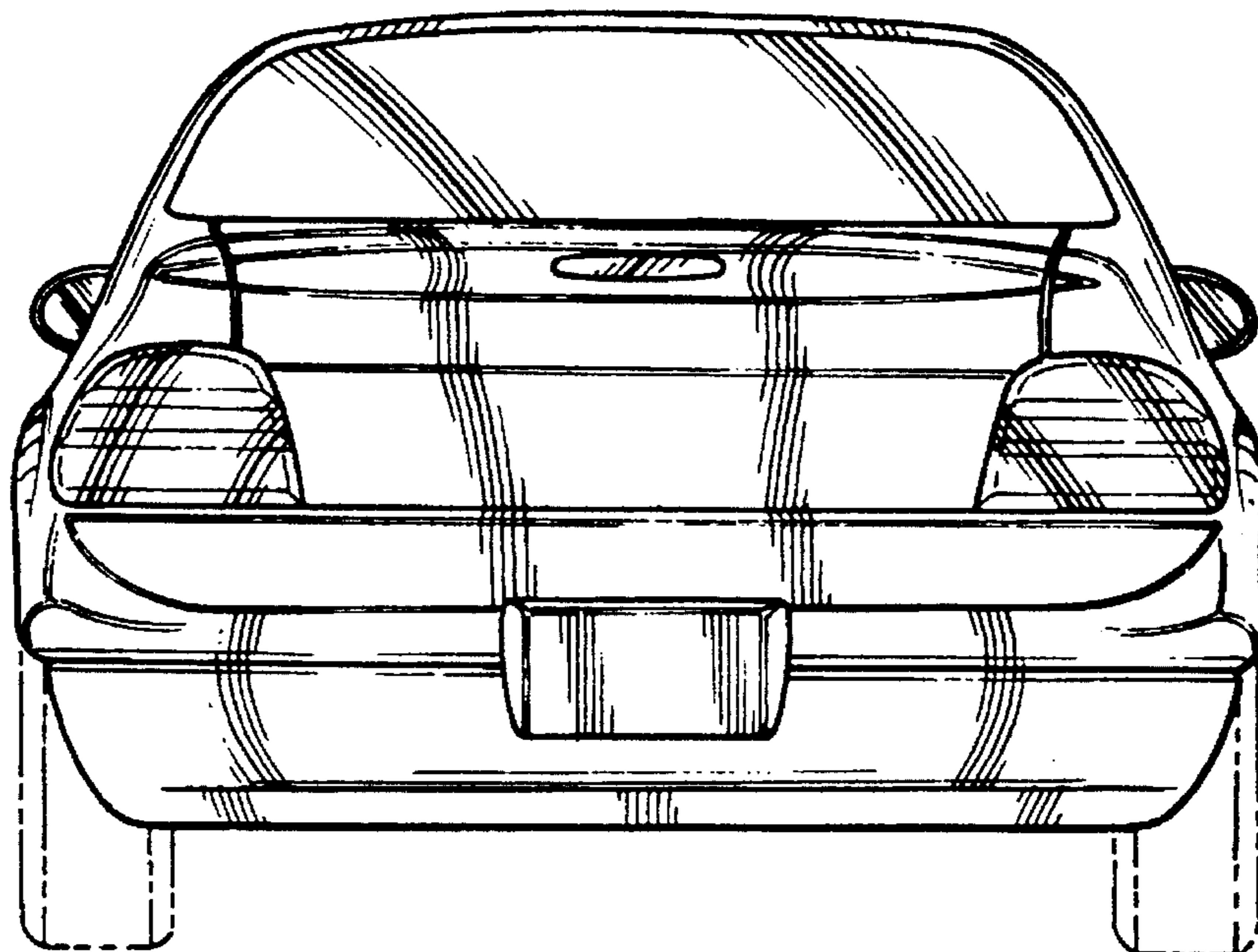

Fig - 9

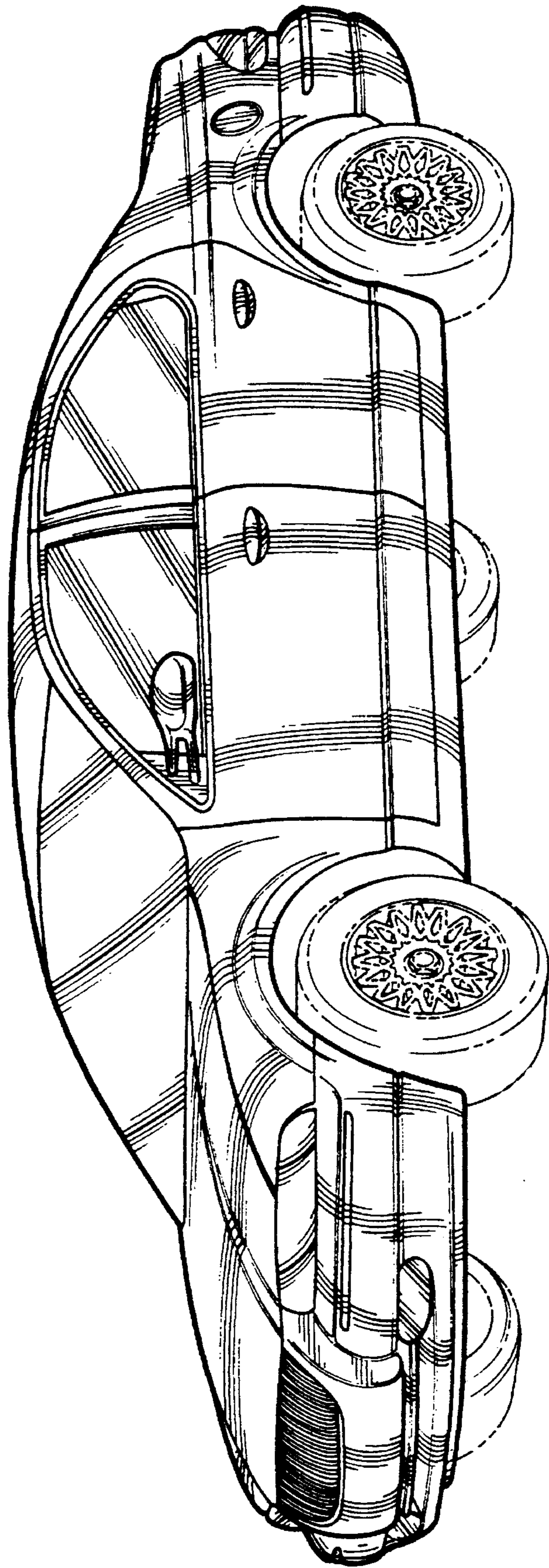

Fig - 10

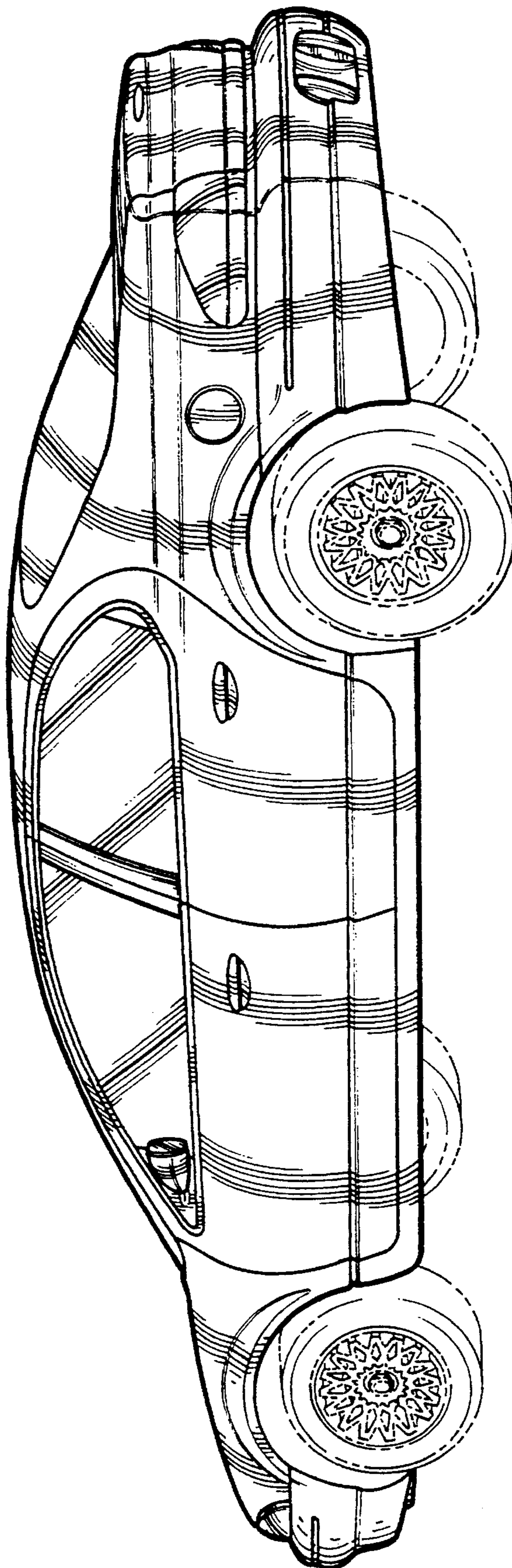

Fig - II

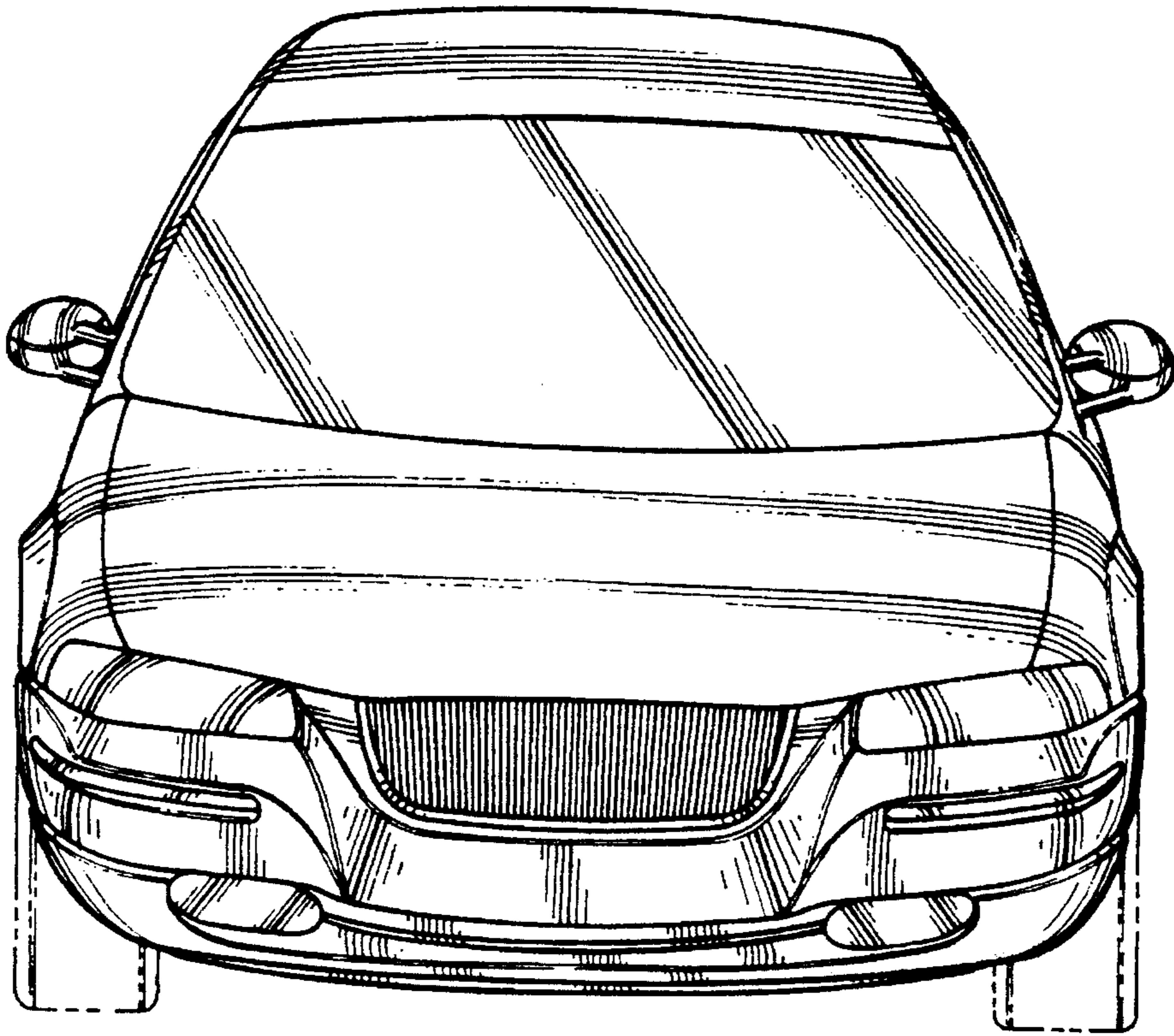

Fig-12

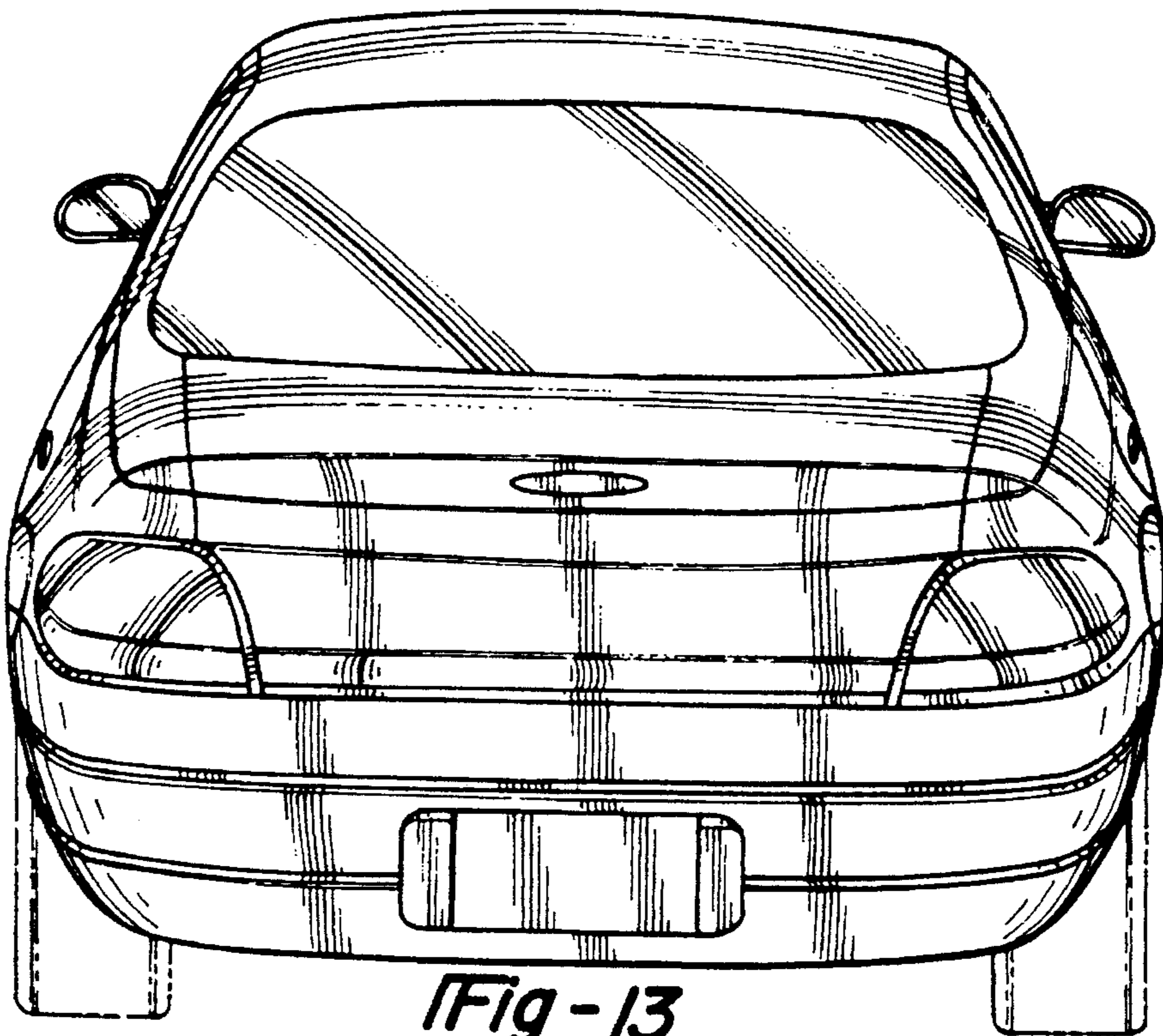

Fig-13