



US00D370684S

United States Patent [19] Johnson

[11] Patent Number: **Des. 370,684**

[45] Date of Patent: ****Jun. 11, 1996**

[54] HAY BAIL TRANSPORT

4,911,596 3/1990 Fetter 414/721

[76] Inventor: **Loyd D. Johnson**, 138 Johnson Ave.,
Bradford, Ark. 72020

OTHER PUBLICATIONS

Implement—Tractor Sep. 21, 1974 p. 32 “Stak-Tote”, center.

[**] Term: **14 Years**

Primary Examiner—Sandra L. Morris

[21] Appl. No.: **23,523**

[57] CLAIM

[22] Filed: **May 26, 1994**

The ornamental design for a hay bail transport, as shown and described.

[52] U.S. Cl. **D15/32**

[58] Field of Search D15/10, 28, 32;
414/24.5, 721, 722, 724, 685

DESCRIPTION

[56] References Cited

FIG. 1 is a perspective view of a hay bail transport showing my new design;

U.S. PATENT DOCUMENTS

D. 239,194	3/1976	Borcherding	D15/32
D. 243,326	2/1977	Vandewater	D15/28
D. 245,984	10/1977	Priefert	D15/32
D. 246,845	1/1978	Sheesley et al.	D15/32
D. 292,136	9/1987	Burenga	D15/32
3,416,686	12/1968	Penrod	414/685
4,023,690	5/1977	Goode	D15/32
4,674,933	6/1987	Brown	414/685

FIG. 2 is an enlarged right side elevational view thereof;

FIG. 3 is an enlarged left side elevational view thereof;

FIG. 4 is an enlarged front elevational view thereof;

FIG. 5 is an enlarged rear elevational view thereof;

FIG. 6 is an enlarged top plan view thereof; and,

FIG. 7 is an enlarged bottom plan view thereof.

1 Claim, 3 Drawing Sheets

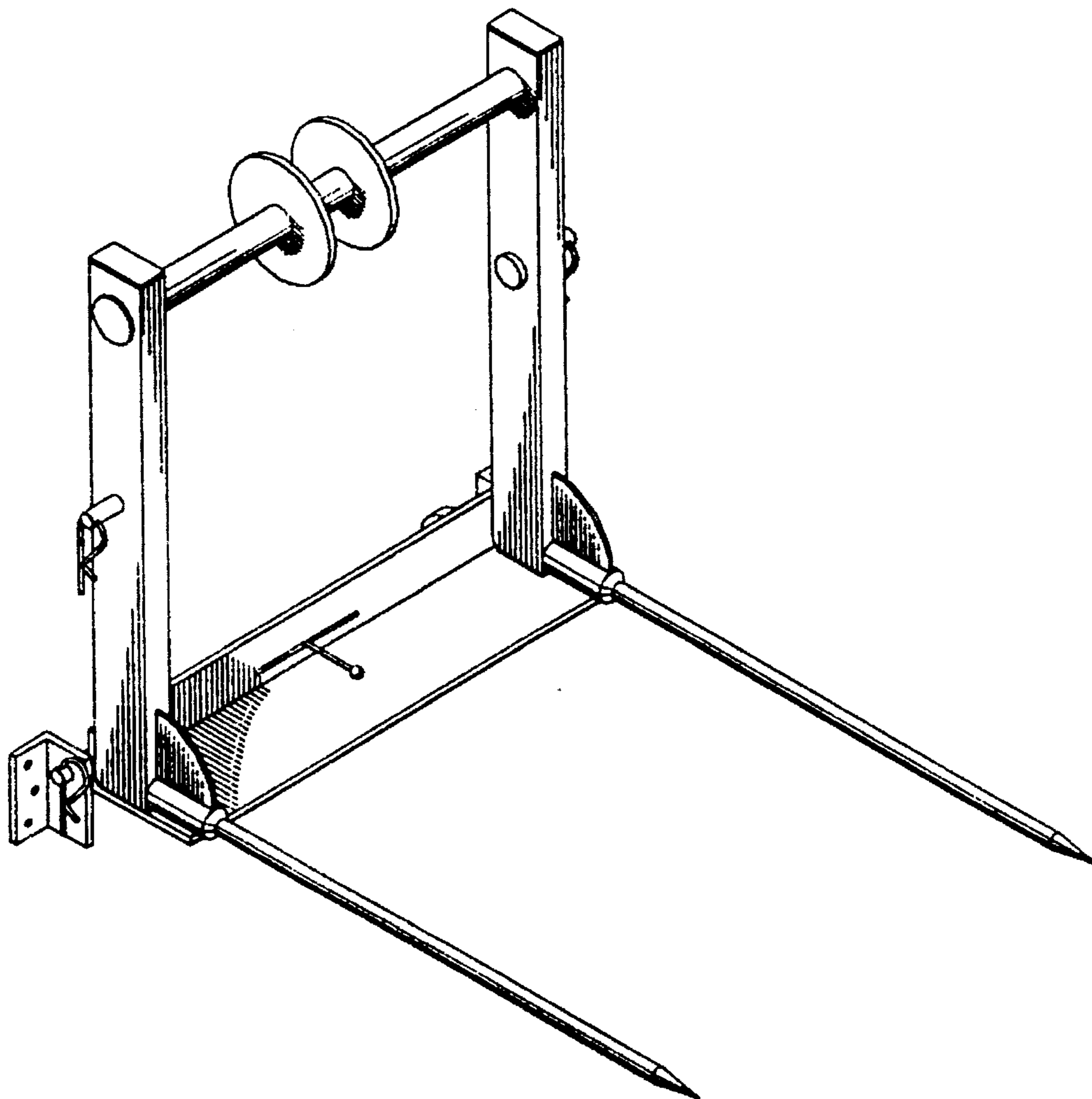

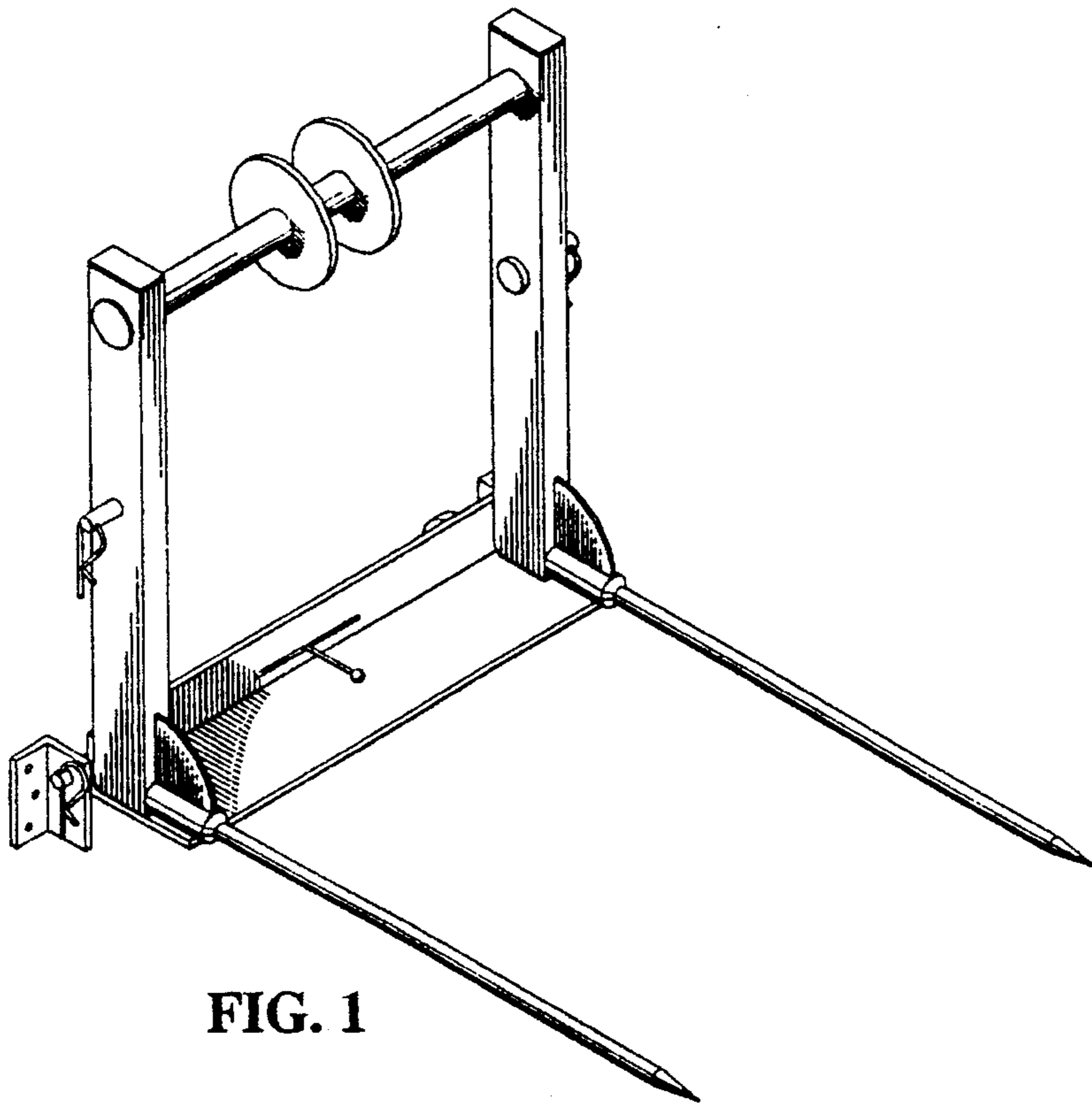

FIG. 1

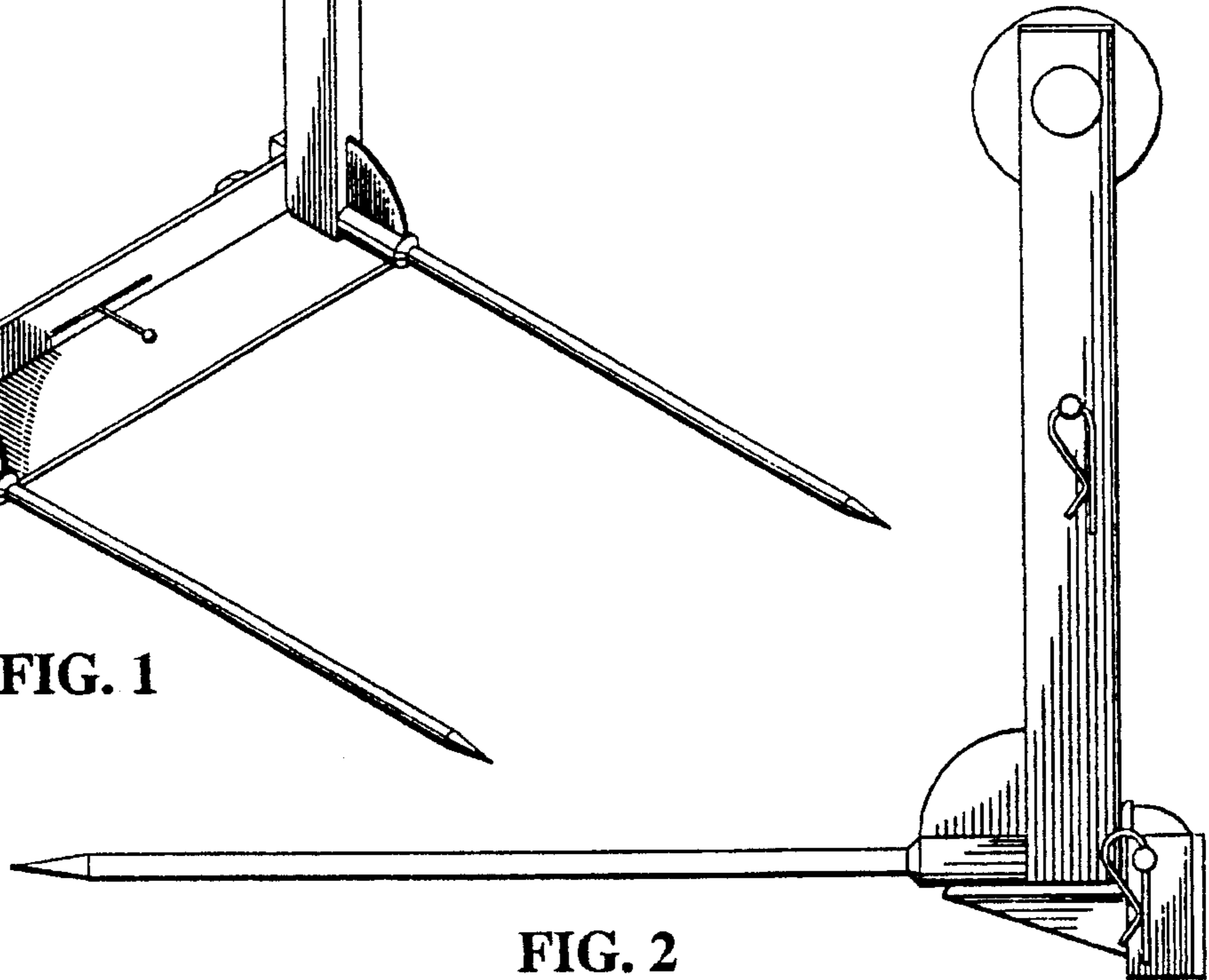

FIG. 2

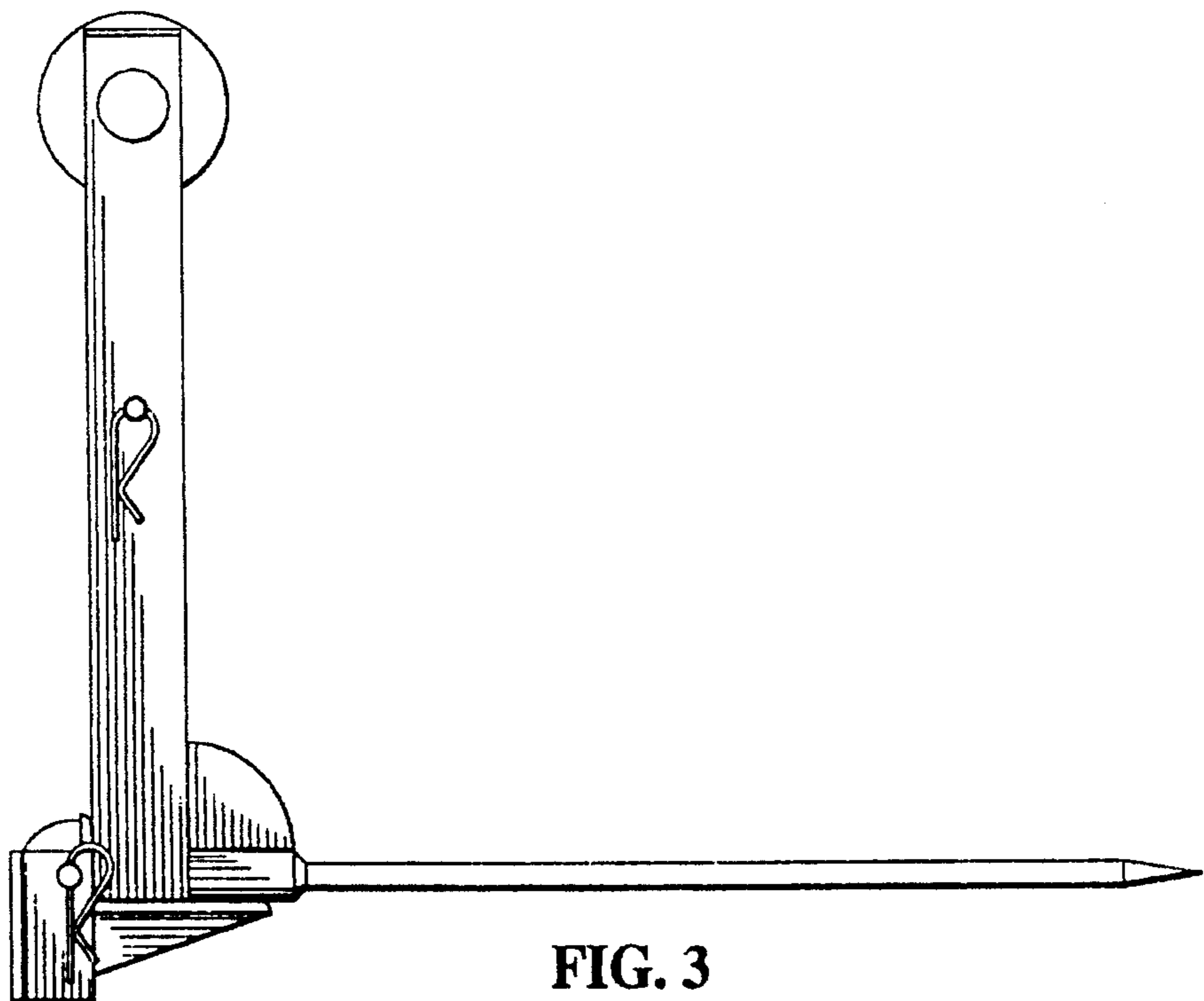

FIG. 3

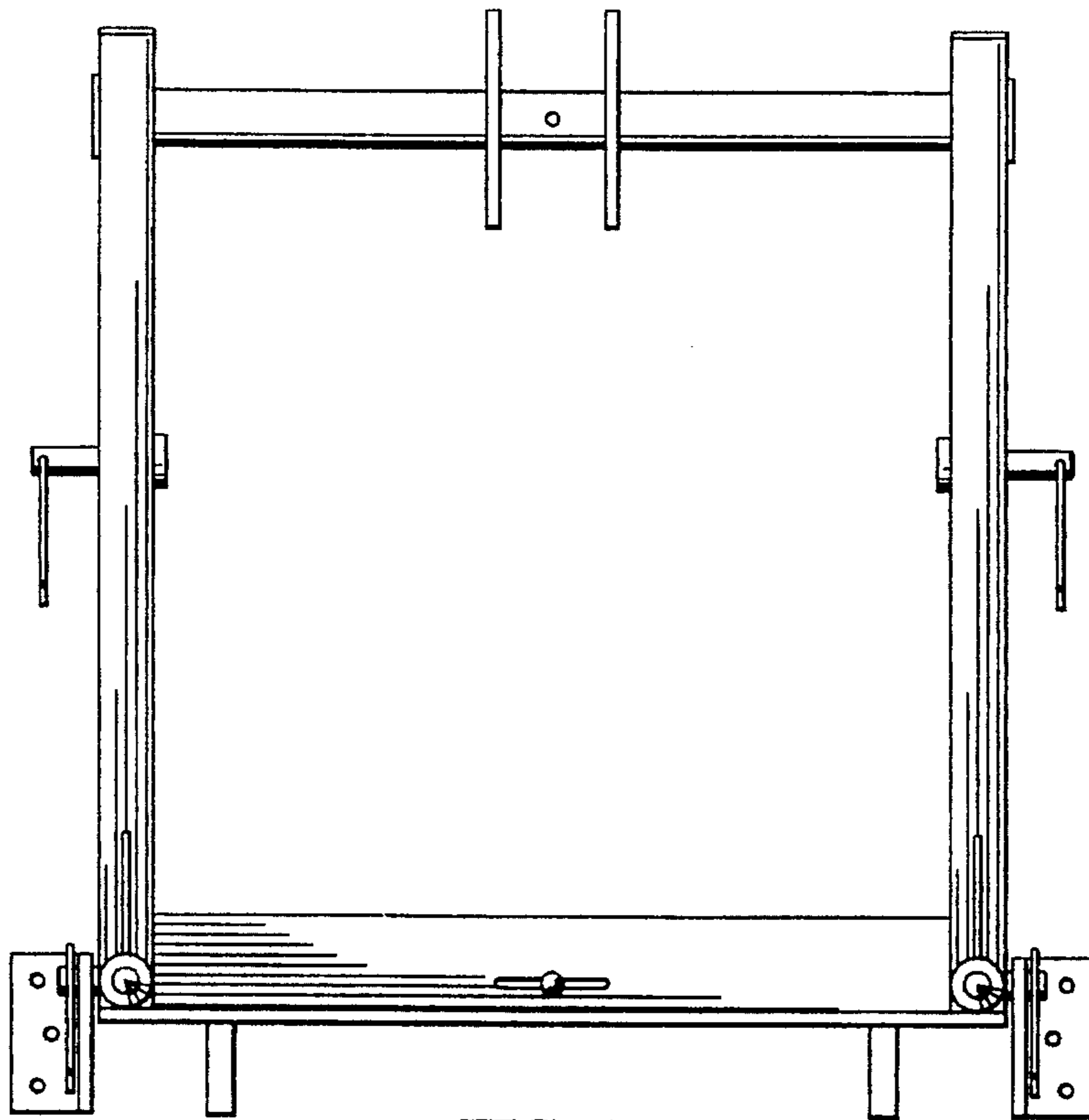

FIG. 4

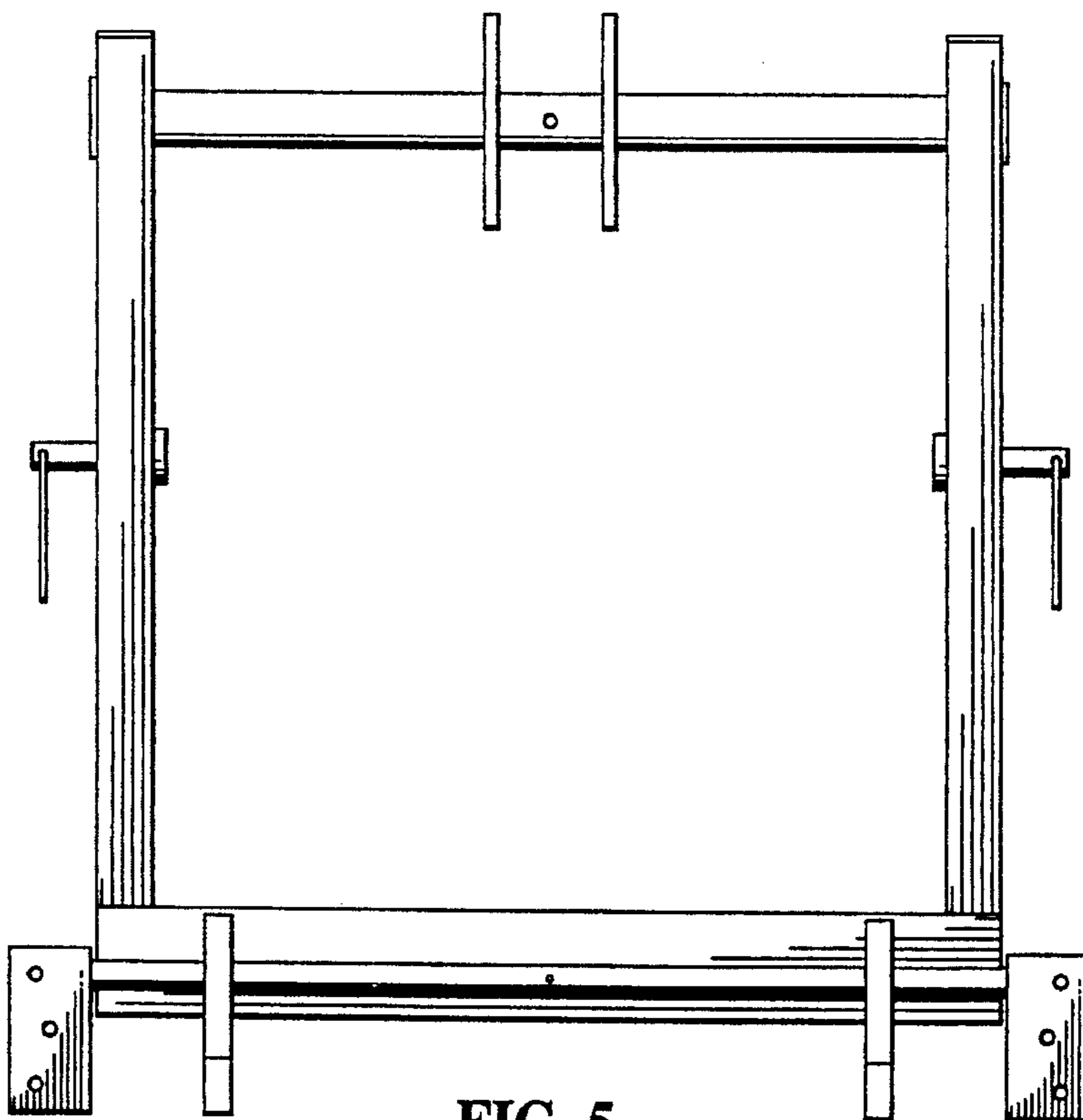

FIG. 5

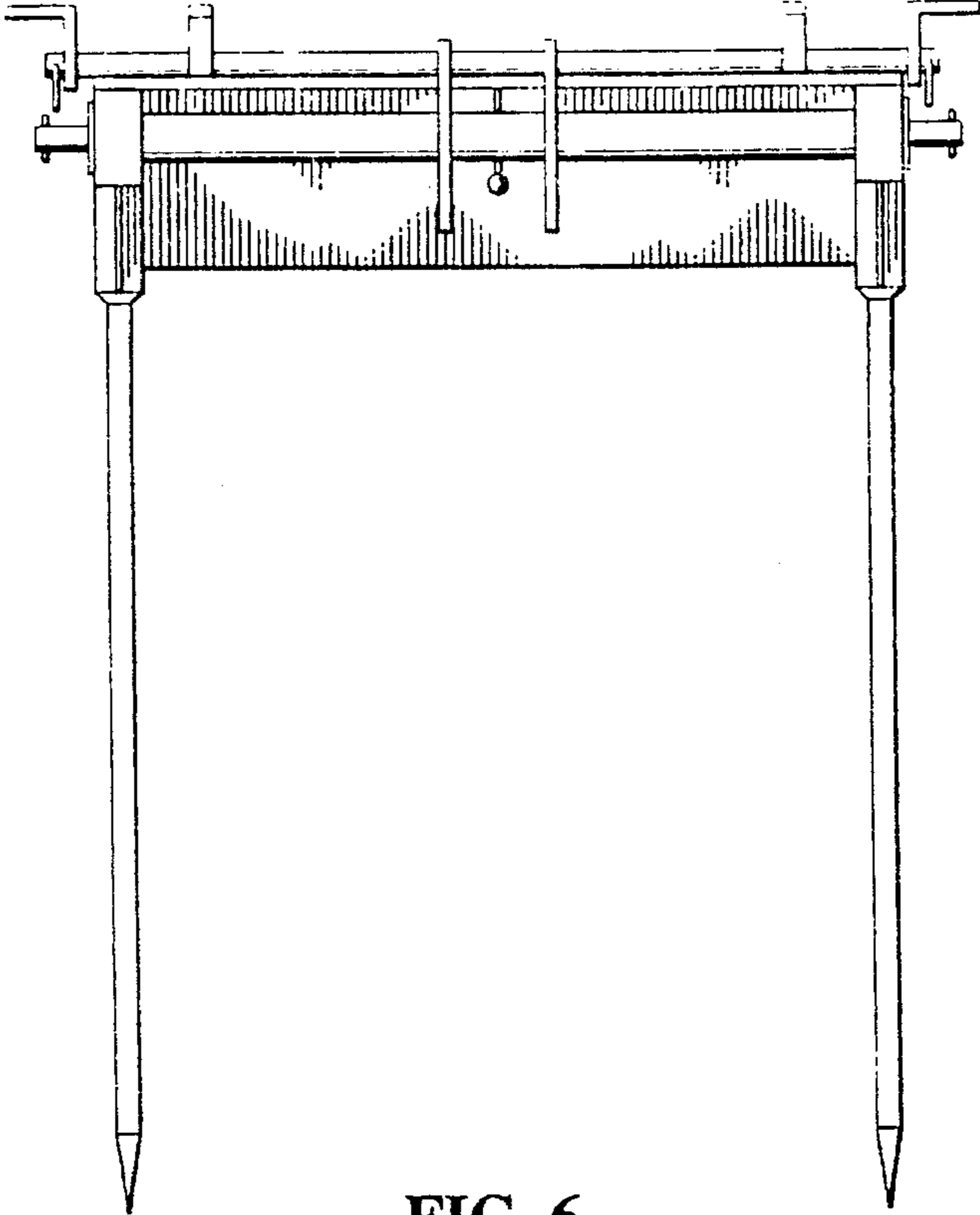

FIG. 6

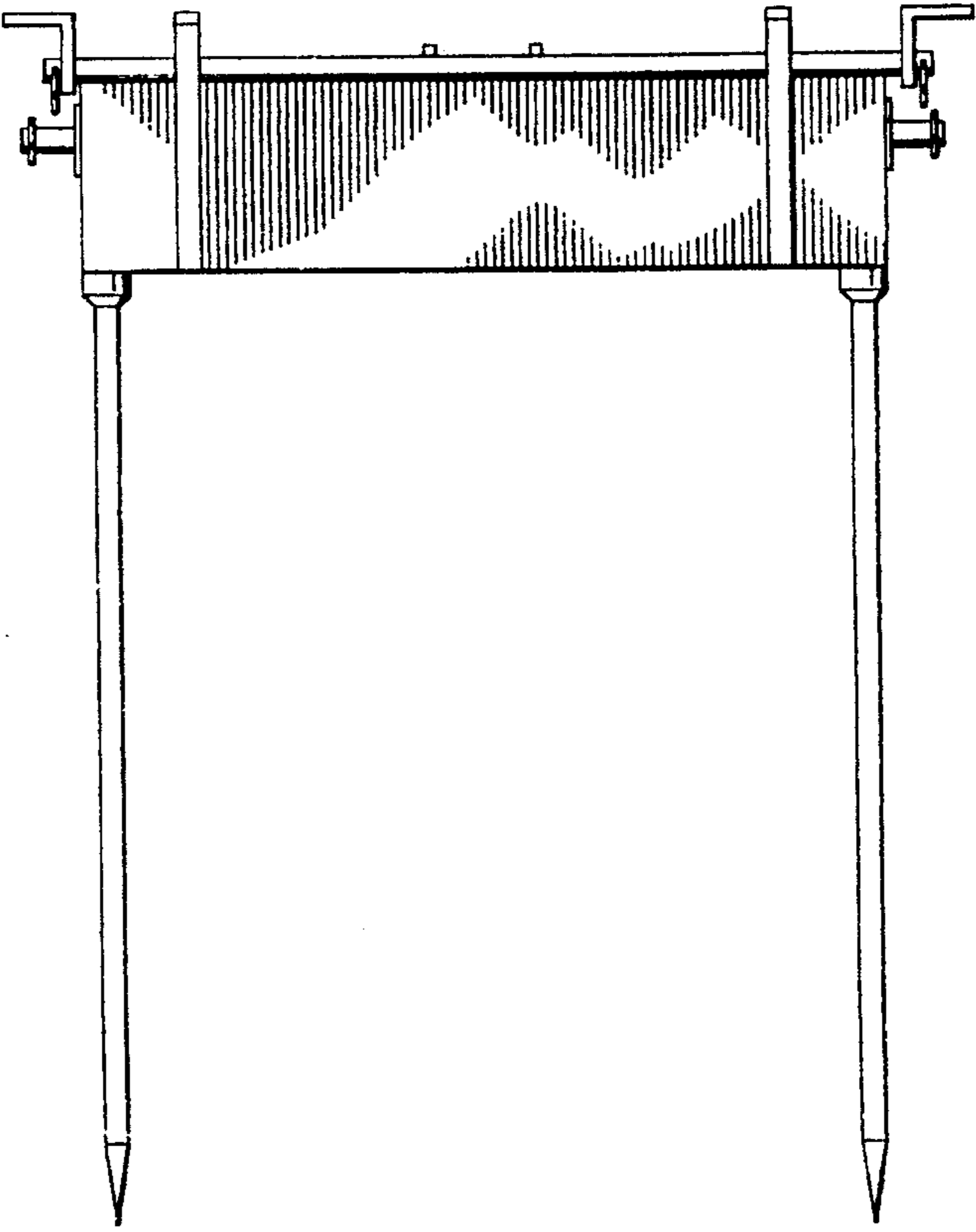

FIG. 7