



US00D370506S

United States Patent [19] Clem

[11] Patent Number: Des. 370,506

[45] Date of Patent: **Jun. 4, 1996

[54] **ABDOMINAL EXERCISE BOARD**

[75] Inventor: **William E. Clem**, Bozeman, Mont.

[73] Assignee: **Tunturi, Inc.**, Redmond, Wash.

[**] Term: **14 Years**

[21] Appl. No.: **34,380**

[22] Filed: **Feb. 3, 1995**

[52] U.S. Cl. **D21/191**

[58] Field of Search D21/191, 195;
482/140, 142, 144, 145, 130, 57

[56] **References Cited**

U.S. PATENT DOCUMENTS

D. 254,562	3/1980	Pearo	D21/195
D. 258,372	2/1981	Pearo	D21/195
D. 262,810	1/1982	Lynn	D21/191
D. 339,617	9/1993	Harashima	D21/191
4,913,424	4/1990	Pepin	482/145
5,125,884	6/1992	Weber et al.	482/142
5,160,305	11/1992	Lin	482/57
5,176,603	1/1993	Hundley et al.	482/140
5,190,513	3/1993	Habing et al.	482/142

OTHER PUBLICATIONS

Information sheet regarding Pinnacle Bench of Vectra Fitness, Inc., Redmond, WA. 1994.

Information sheets (2) regarding Bodysmith Flat and Incline Combo exercise bench, by ParaBody, Inc. of Ramsey, MN.

Information sheets (2) regarding adjustable incline bench A 40, flat to military bench A 59 and flat bench A 44 of Apex Gym Equipment.

Information sheets (2) regarding 13-51 Slant Board/Ladder 5000-10 and regarding 3-8 Let Extension/Leg Curl 1500-18 by Continental Systems of Jonesboro, AR 1989.

Primary Examiner—Philip S. Hyder

Attorney, Agent, or Firm—Graybeal Jackson Haley & Johnson

[57] **CLAIM**

The ornamental design for an abdominal exercise board, as shown and described.

DESCRIPTION

FIG. 1 is a front perspective view of the abdominal exercise board showing my new design;

FIG. 2 is a rear view in elevation of the abdominal exercise board of FIG. 1;

FIG. 3 is a front view in elevation of the abdominal exercise board of FIG. 1;

FIG. 4 is a side view in elevation as seen from the right-hand side of the abdominal exercise board of FIG. 1;

FIG. 5 is a side view in elevation as seen from the left-hand side of the abdominal exercise board of FIG. 1;

FIG. 6 is a top plan view of the abdominal exercise board of FIG. 1; and,

FIG. 7 is a bottom plan view of the abdominal exercise board of FIG. 1.

1 Claim, 3 Drawing Sheets

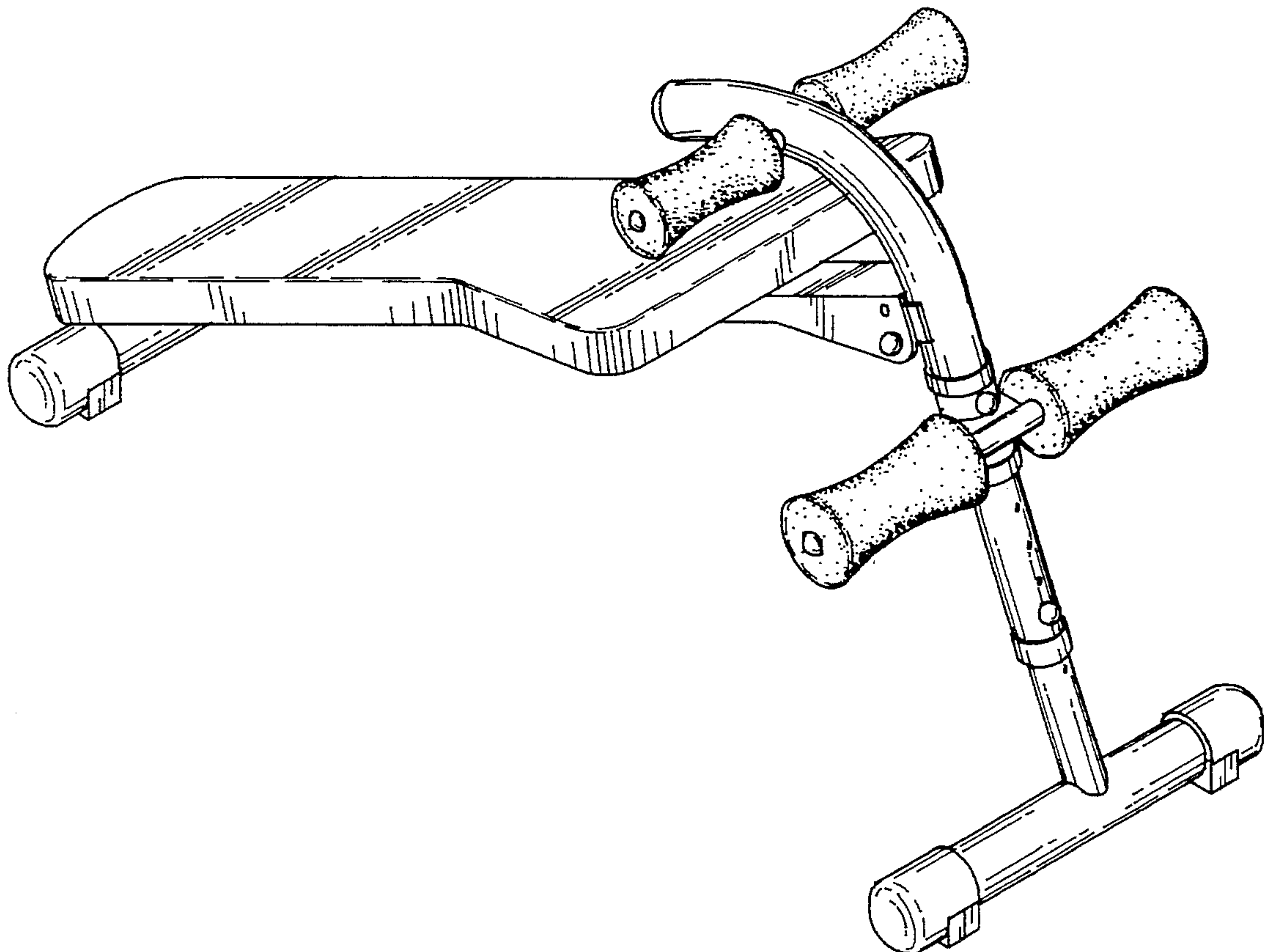

FIG. 1

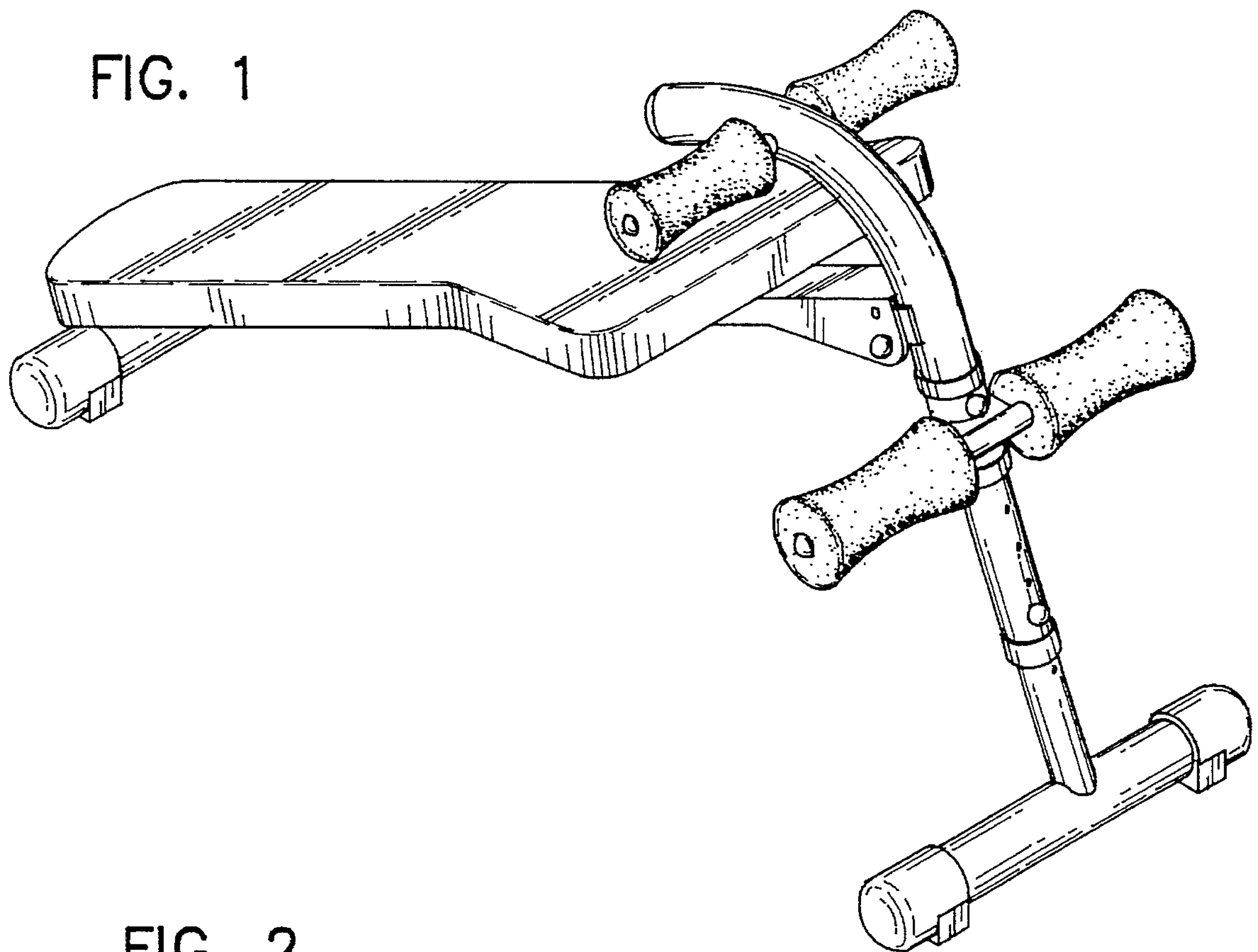

FIG. 2

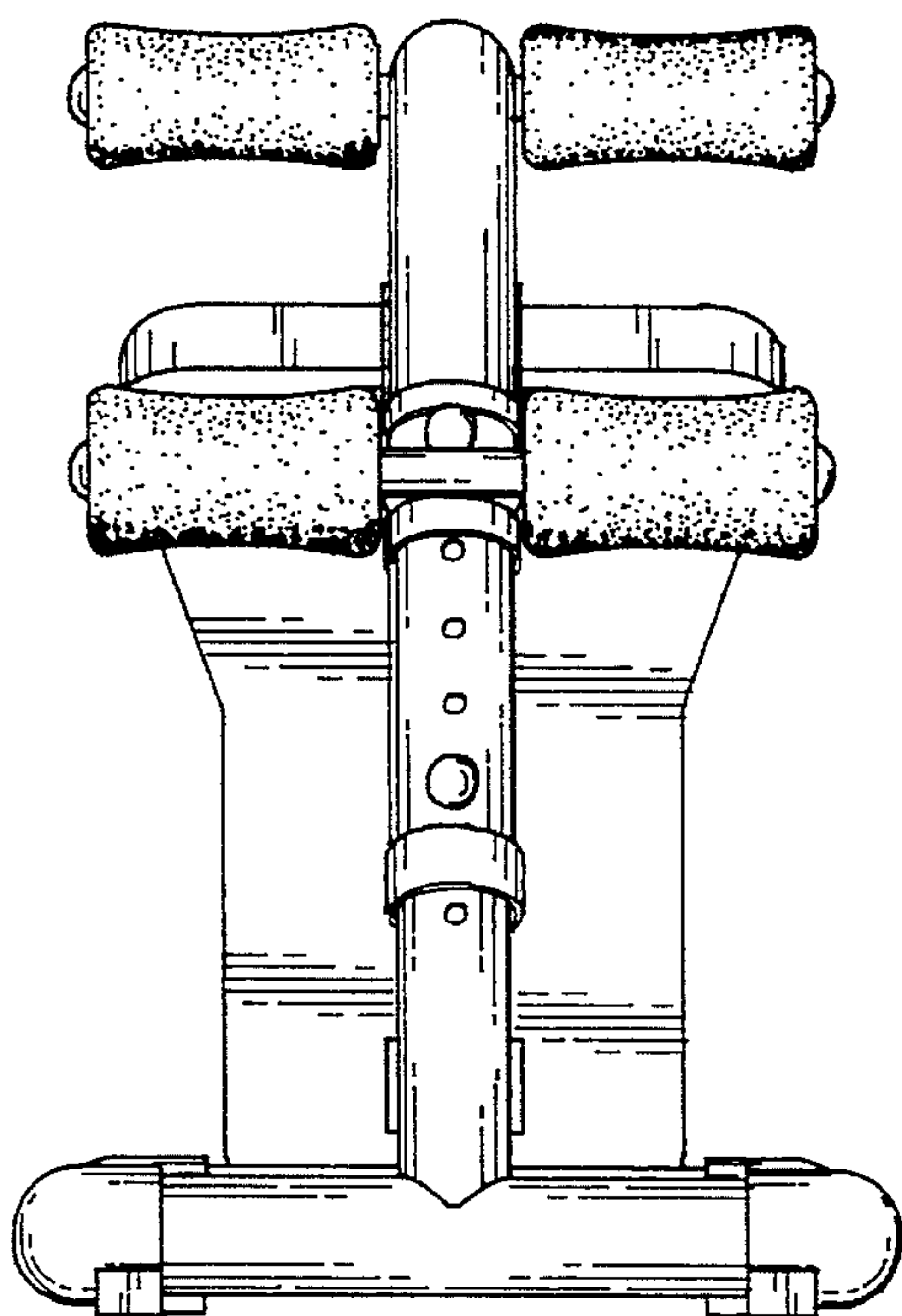
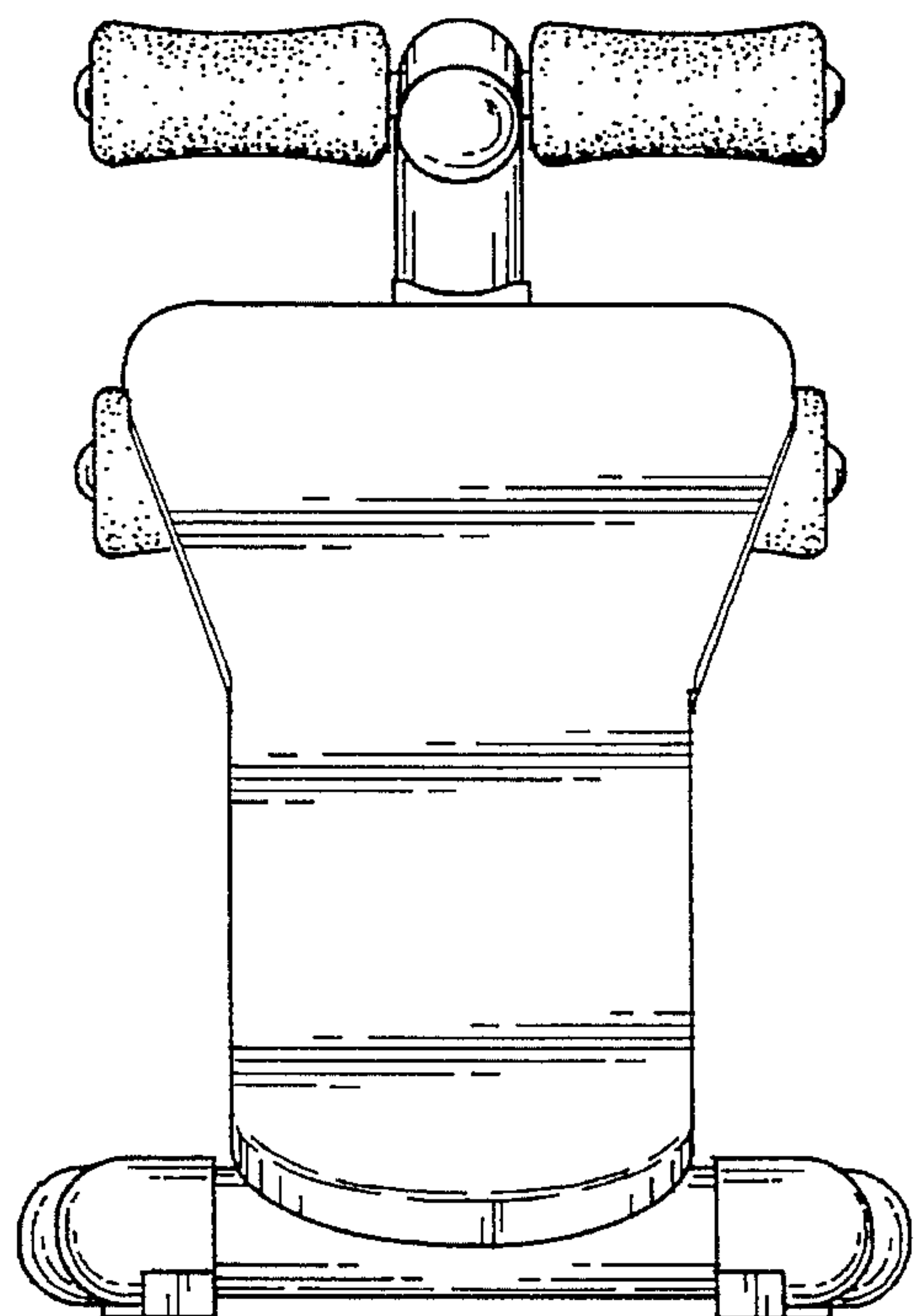
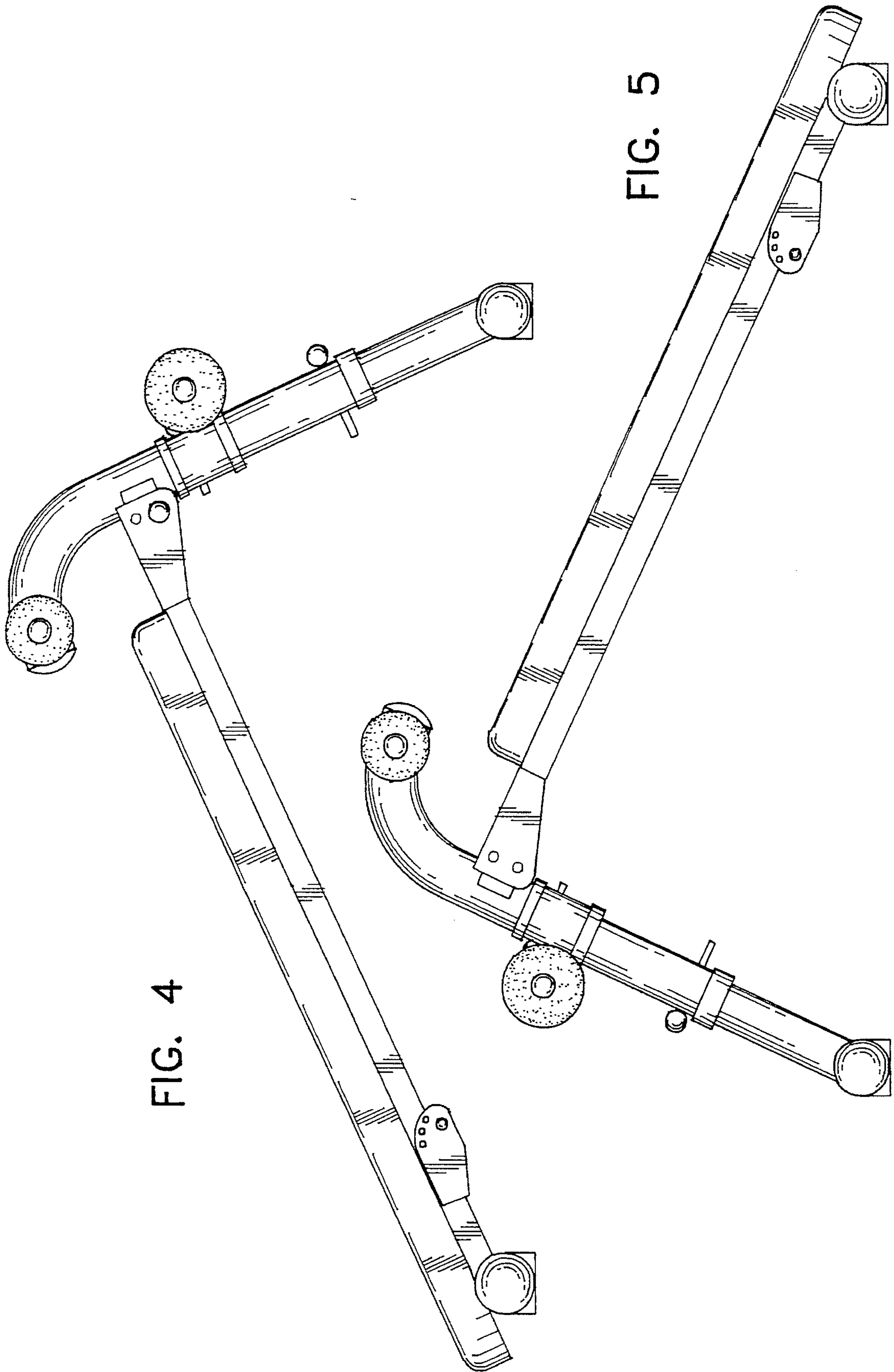

FIG. 3





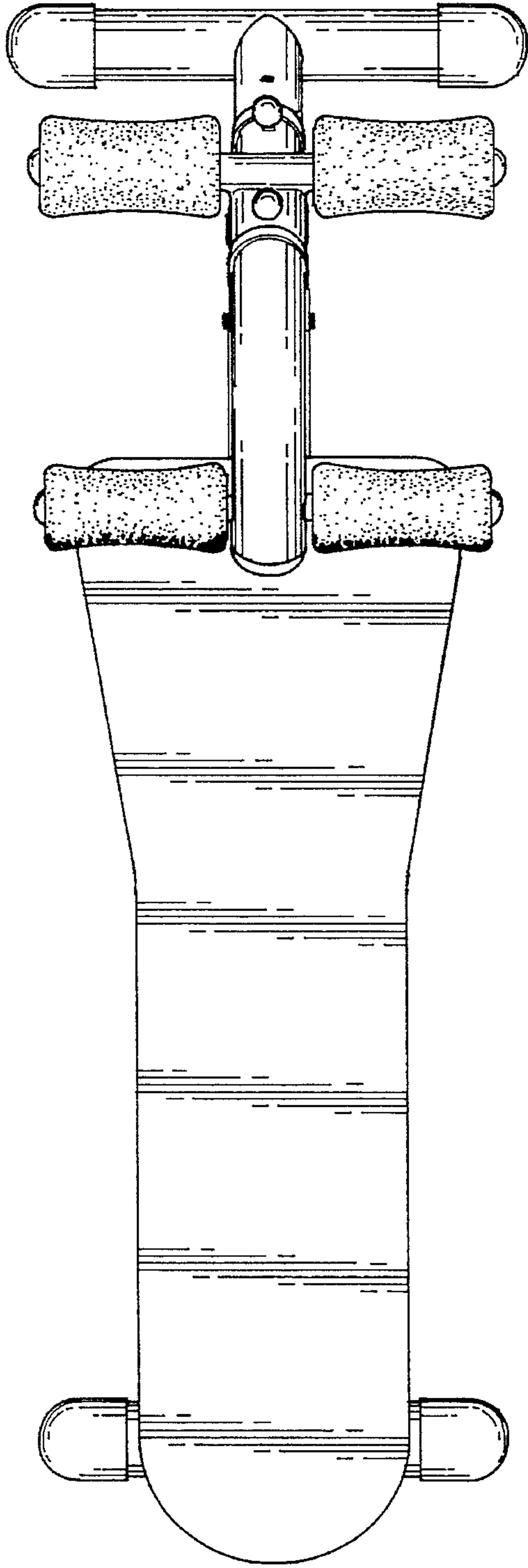

FIG. 6

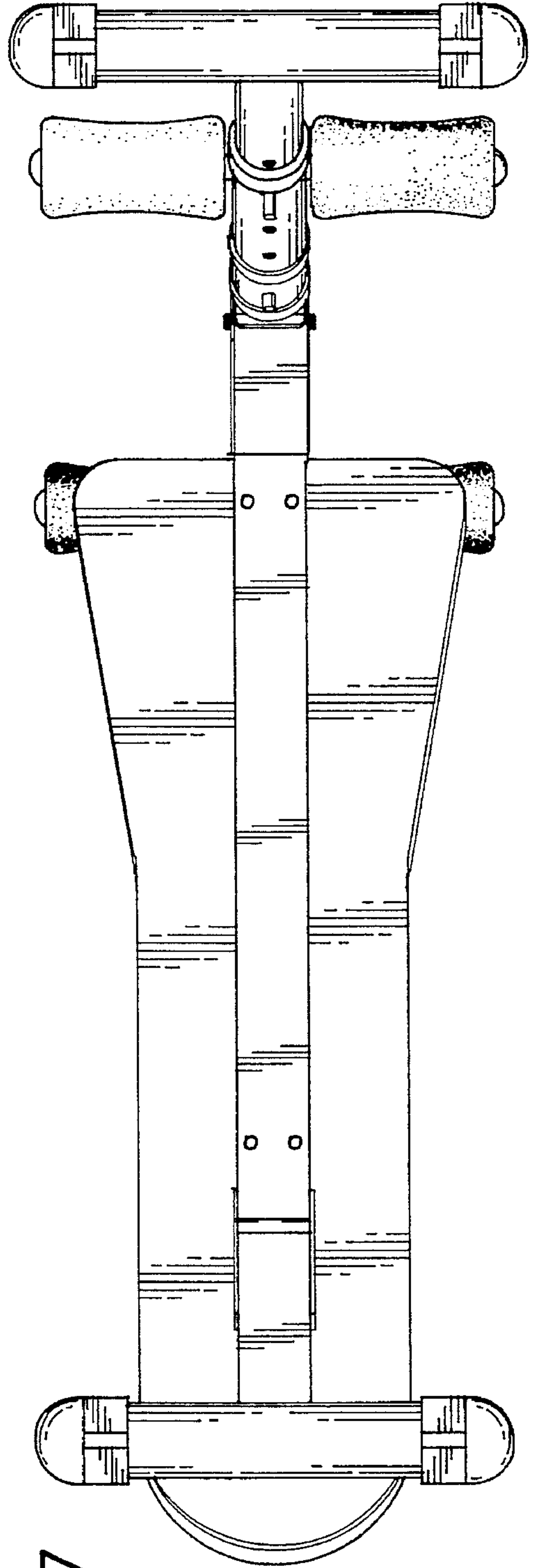

FIG. 7