



US00D370456S

United States Patent [19]

Buchsel et al.

[11] Patent Number: **Des. 370,456**

[45] Date of Patent: ****Jun. 4, 1996**

[54] **LARGE, SINGLE DECK, HIGH WING AIRPLANE**

D. 354,474	1/1995	Murphy et al.	D12/319
D. 358,576	5/1995	Sutter et al.	D12/337
D. 358,577	5/1995	Sutter et al.	D12/337

[75] Inventors: **Christian K. C. Buchsel**, Issaquah; **James D. Callahan**, Bellevue; **David C. Clinton**, Seattle, all of Wash.

Primary Examiner—Kay H. Chin
Attorney, Agent, or Firm—Daniel T. Anderson; Bernard A. Donahue

[73] Assignee: **The Boeing Company**, Seattle, Wash.

[57] **CLAIM**

[**] Term: **14 Years**

The ornamental design for a large, single deck, high wing airplane, as shown and described.

[21] Appl. No.: **37,321**

DESCRIPTION

[22] Filed: **Apr. 4, 1995**

[52] U.S. Cl. **D12/340; D12/319**

FIG. 1 is a left side elevational view of a large, single deck, high wing airplane showing our new design, the right side elevation being a mirror image of this view; FIG. 2 is a front elevational view thereof; FIG. 3 is a rear elevational view thereof; FIG. 4 is a top, plan view thereof; and, FIG. 5 is a bottom view thereof.

[58] Field of Search D12/319, 340, D12/341, 343, 337; 244/45 A, 45 R, 15, 46

[56] **References Cited**

U.S. PATENT DOCUMENTS

D. 326,842 6/1992 Buchsel et al. D12/319

1 Claim, 4 Drawing Sheets

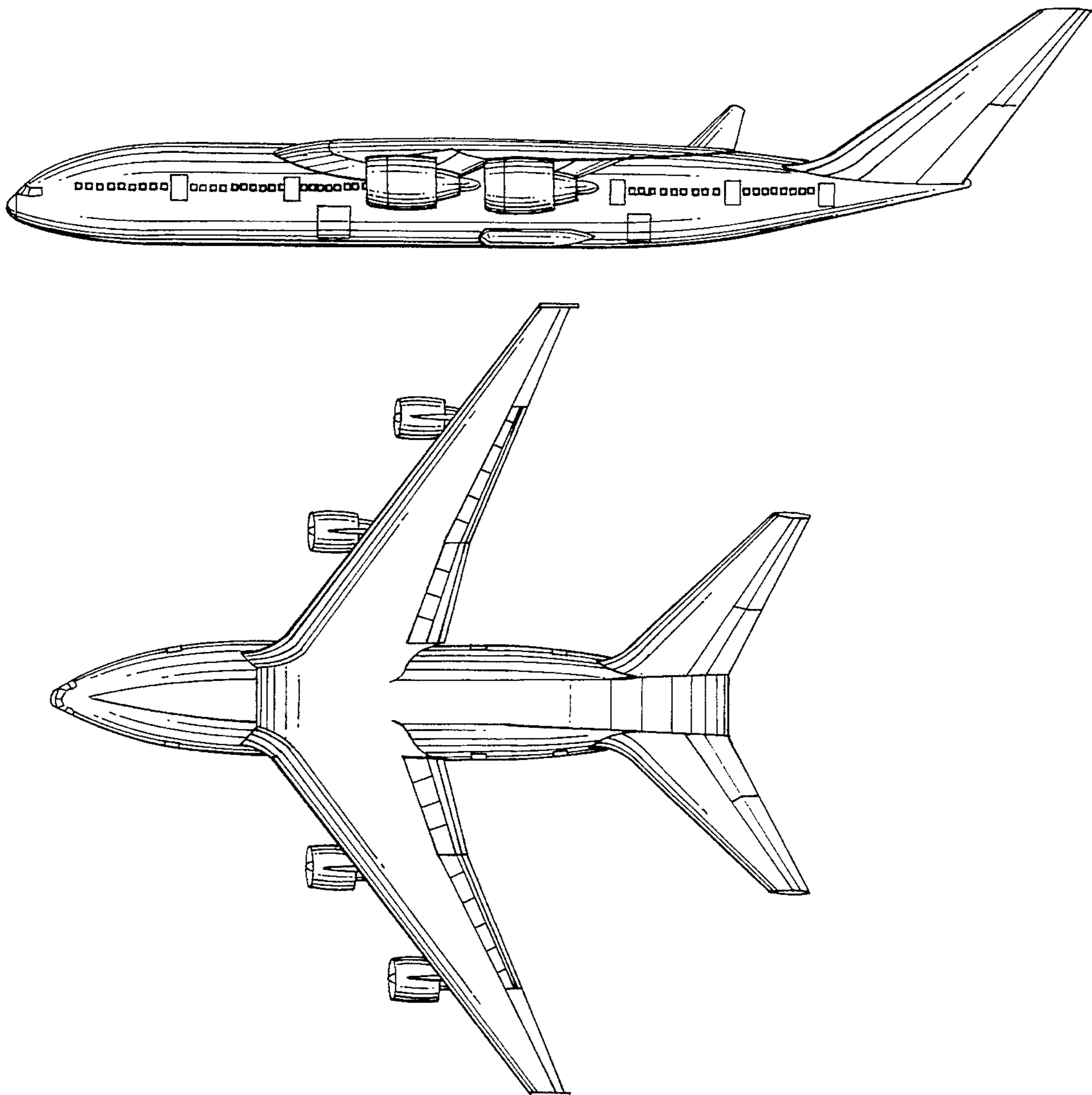

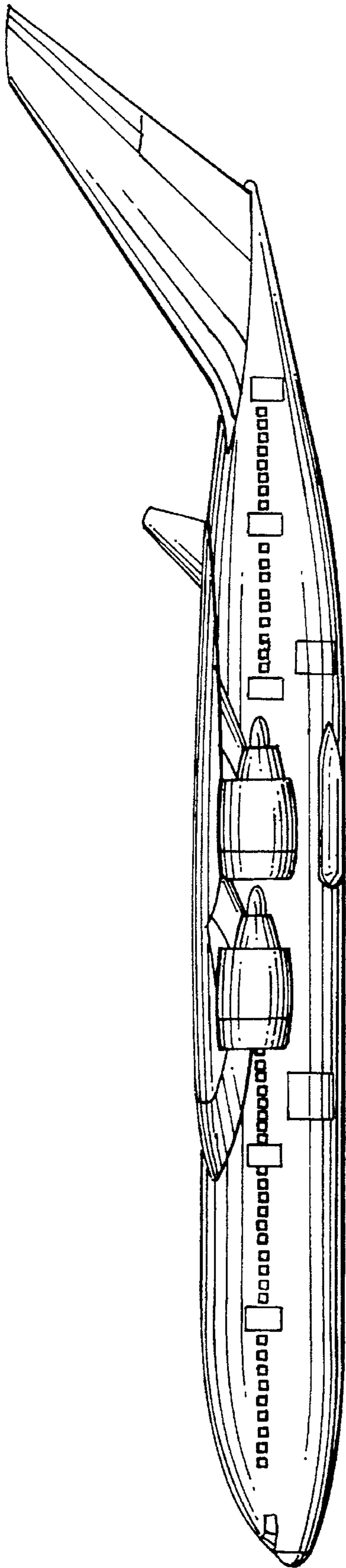

Fig. 1

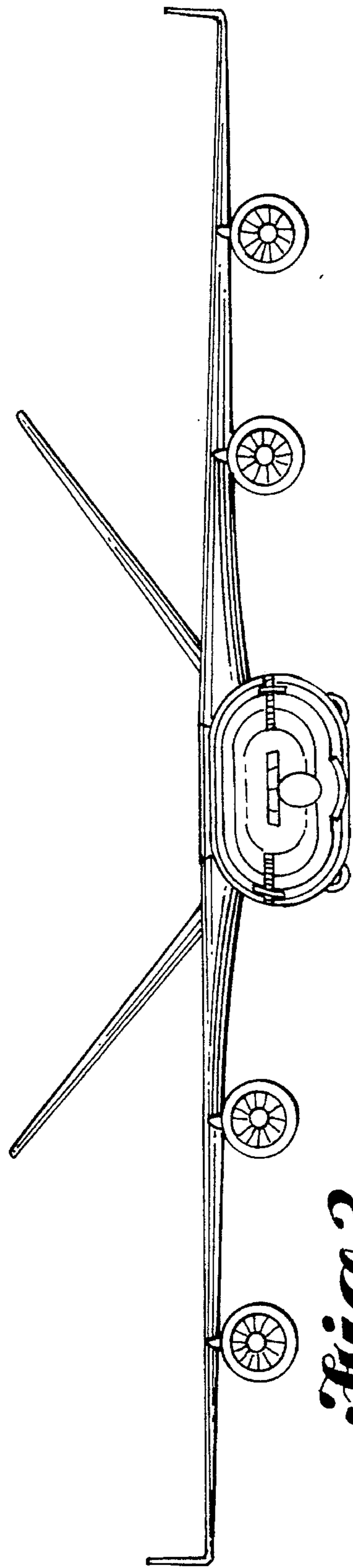

Fig. 2

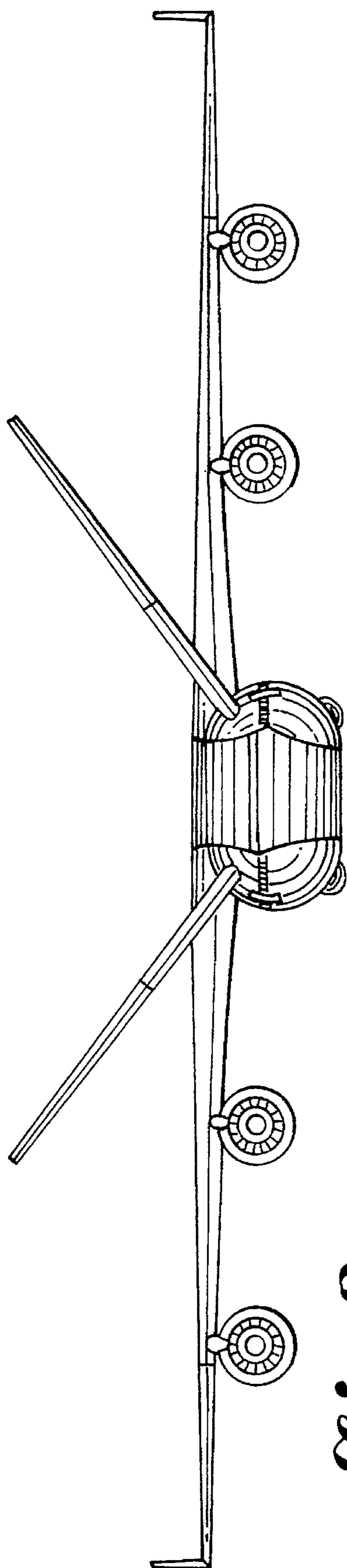

Fig. 3

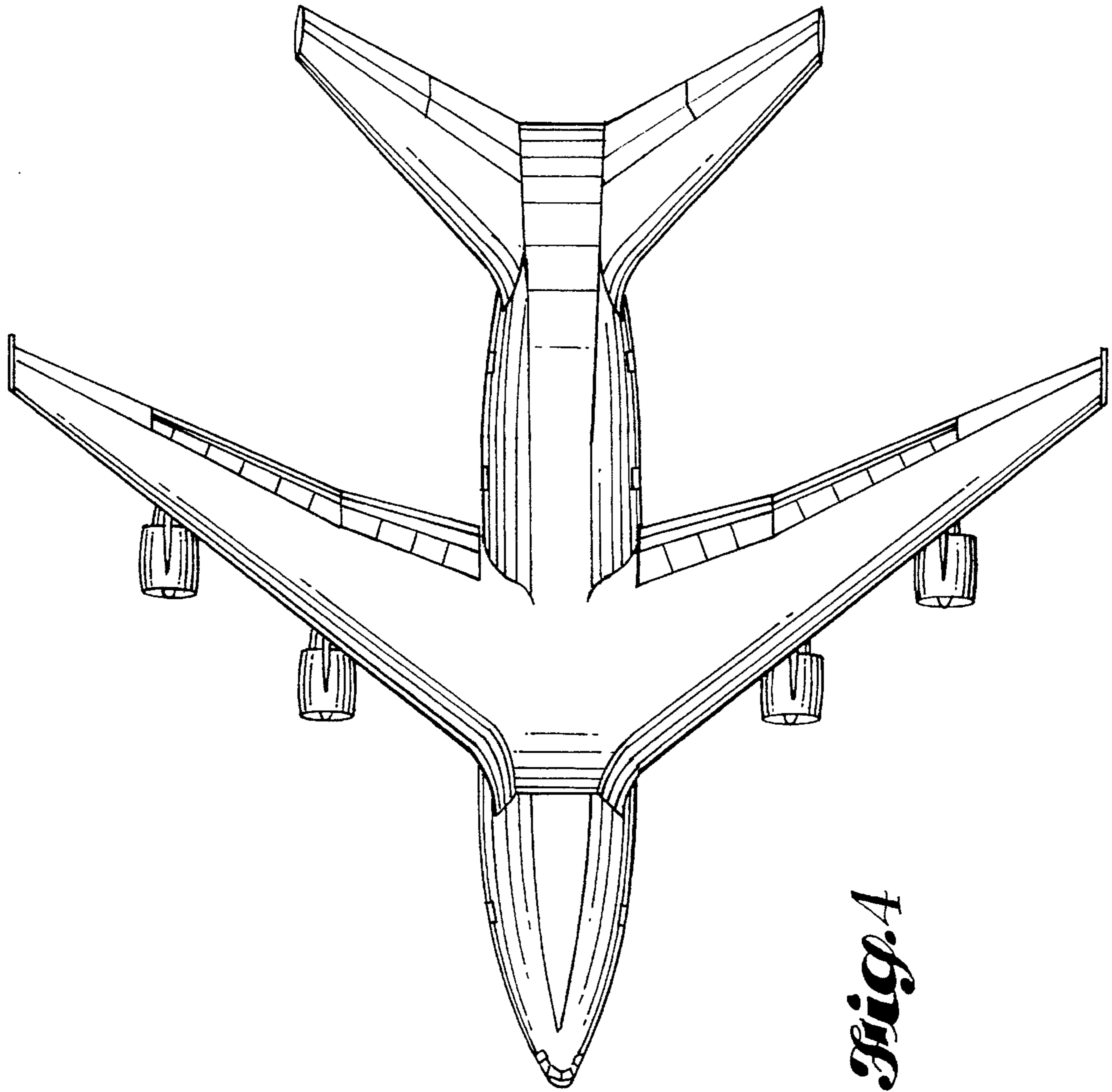

Fig. 4

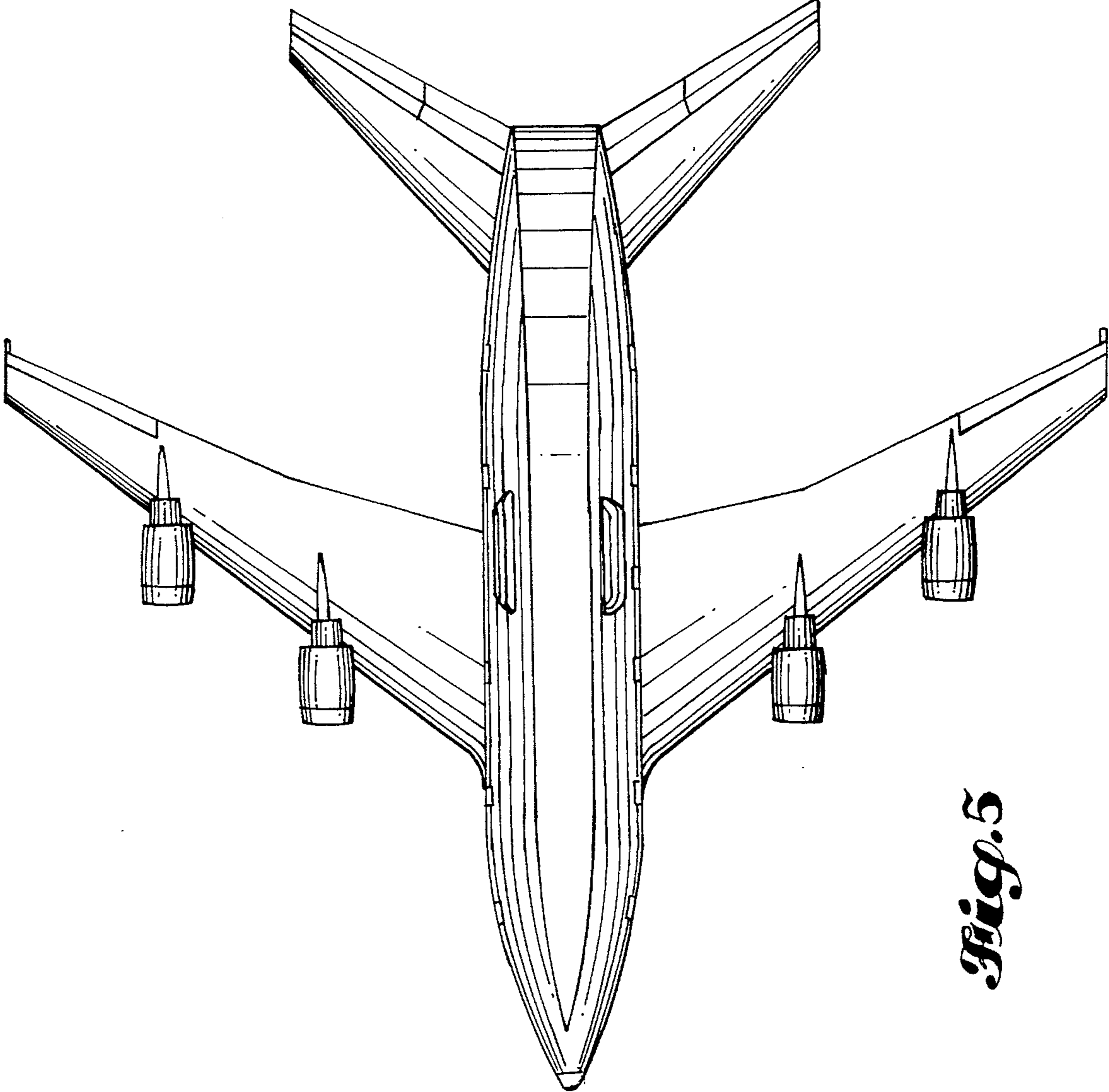

Fig. 5