



US00D370447S

United States Patent [19]
Parker

[11] **Patent Number: Des. 370,447**
[45] **Date of Patent: **Jun. 4, 1996**

[54] **VEHICLE IMPACT ABSORBER**

[76] Inventor: **Lloyd J. Parker**, 2020 Nottingham Cir.,
Junction City, Kans. 66441

[**] Term: **14 Years**

[21] Appl. No.: **28,052**

[22] Filed: **Sep. 6, 1994**

[52] U.S. Cl. **D12/169**

[58] Field of Search D12/167, 169,
D12/181; 293/102, 117, 120, 131, 132,
143, 146; 296/180.1, 180.2

[56] **References Cited**

U.S. PATENT DOCUMENTS

- D. 163,455 5/1951 Grilley et al. D12/169
- D. 269,423 6/1983 Waite D12/169
- D. 280,891 10/1985 Belsky et al. D12/169

Primary Examiner—A. Hugo Word
Assistant Examiner—Lavone Tabor
Attorney, Agent, or Firm—John W. Carpenter

[57] **CLAIM**

The ornamental design for a vehicle impact absorber, as shown and described.

DESCRIPTION

FIG. 1 is a perspective view of a vehicle impact absorber; FIG. 2 is a top plan view of a vehicle impact absorber; FIG. 3 is a bottom plan view of a vehicle impact absorber; FIG. 4 is a front elevational view of a vehicle impact absorber; FIG. 5 is a rear elevational view of a vehicle impact absorber; FIG. 6 is an end view of a vehicle impact absorber; and, FIG. 7 and another end view of a vehicle impact absorber.

1 Claim, 2 Drawing Sheets

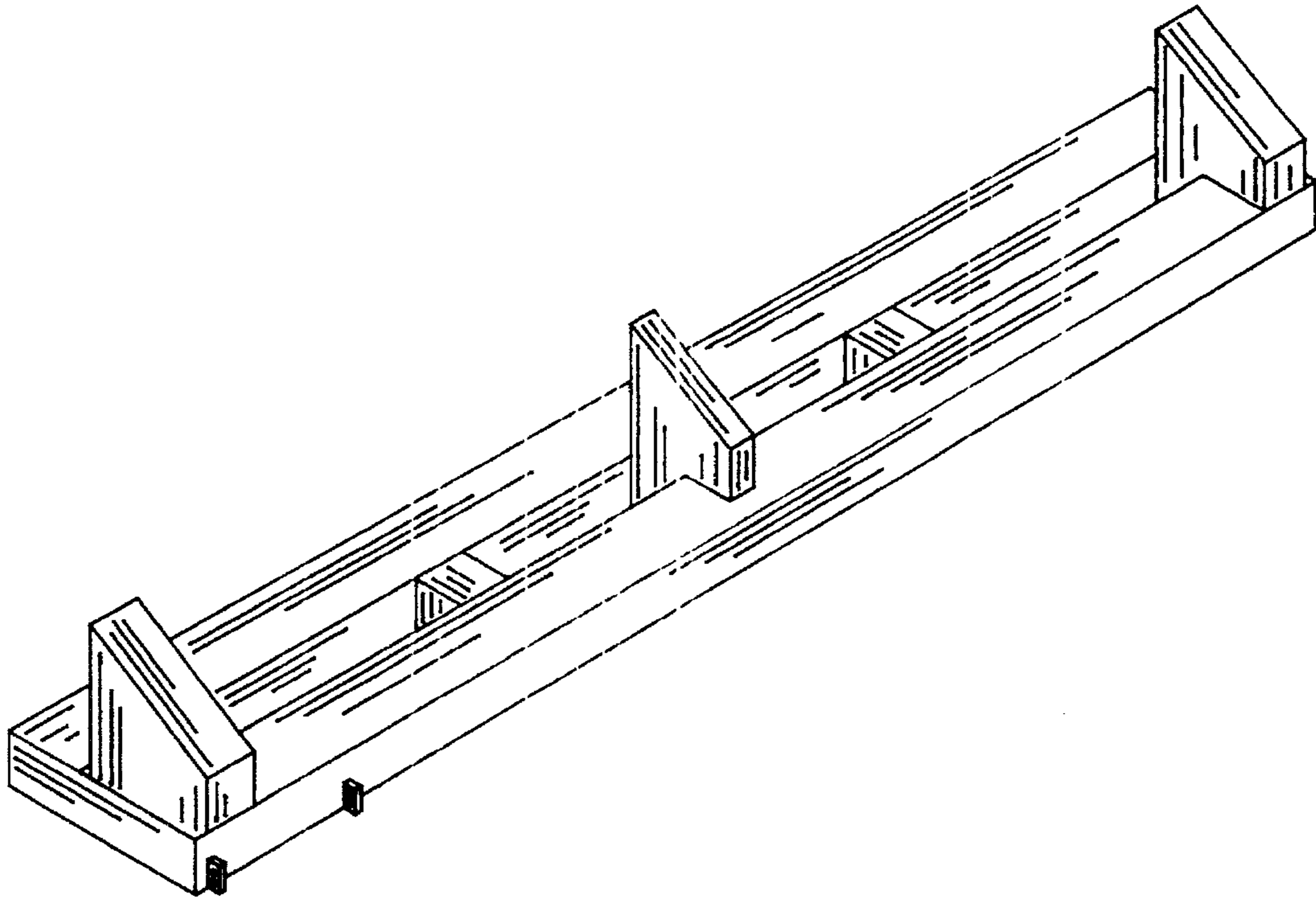

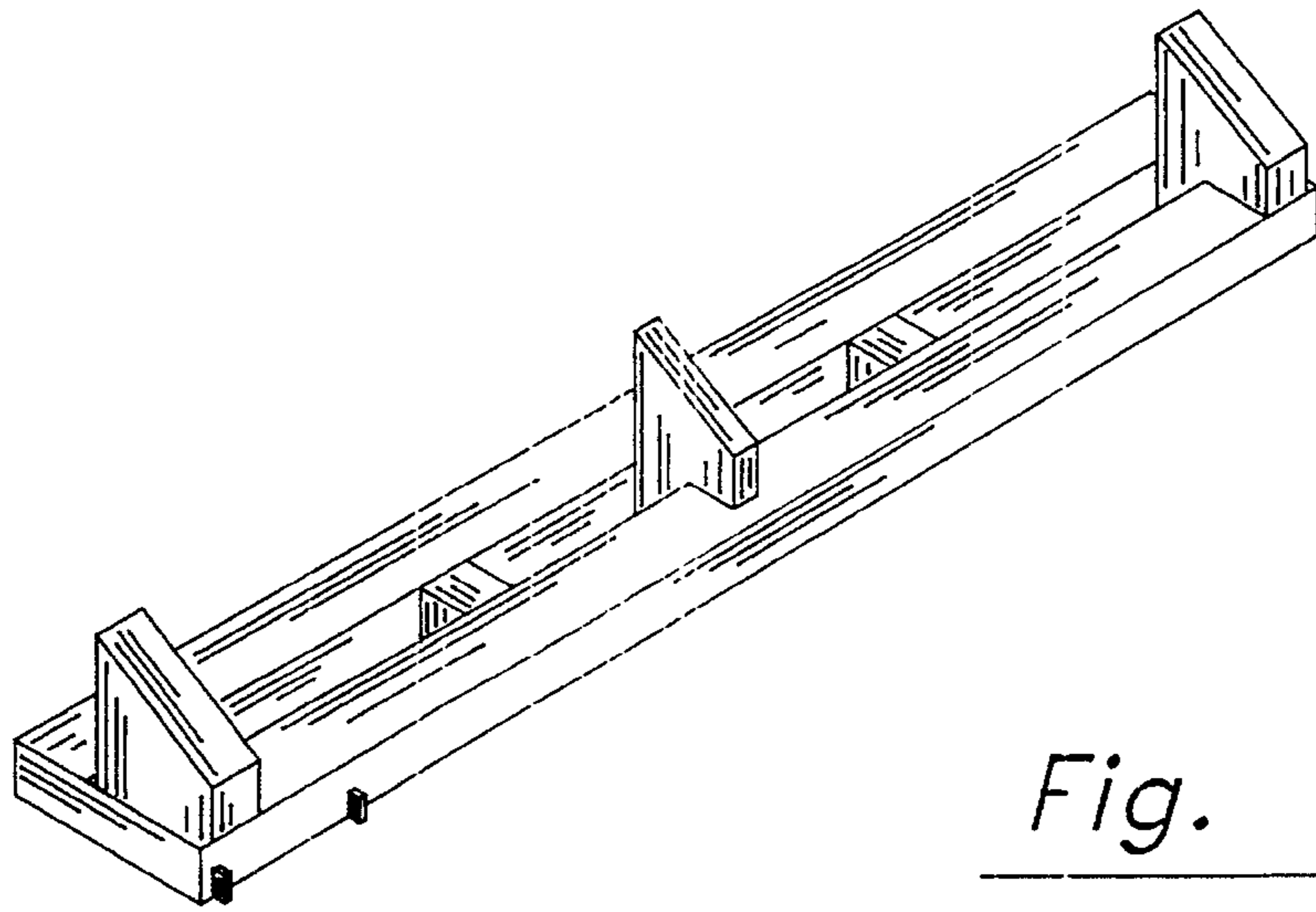

Fig. 1

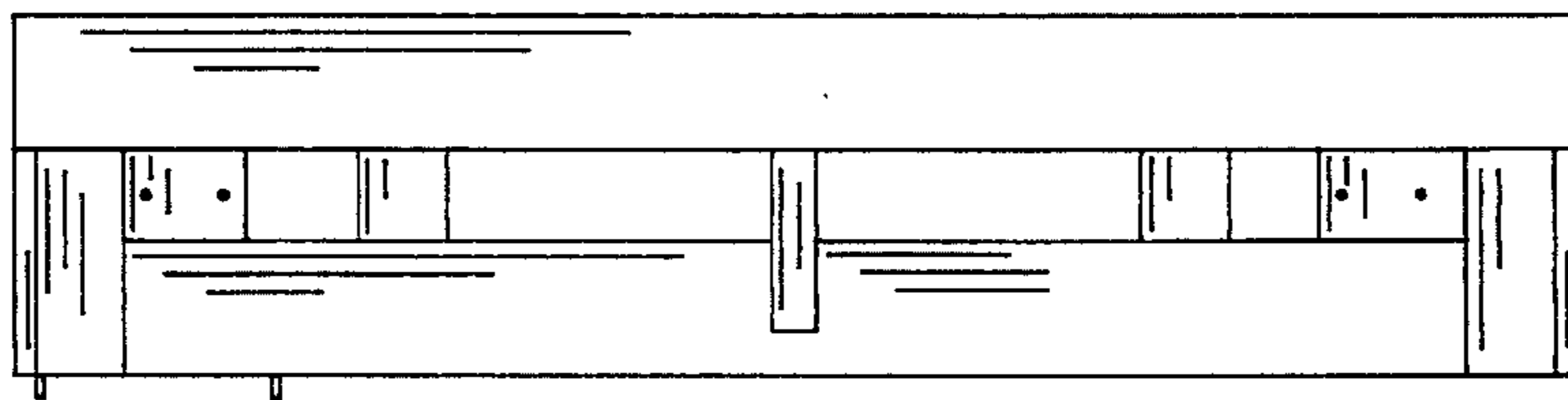

Fig. 2

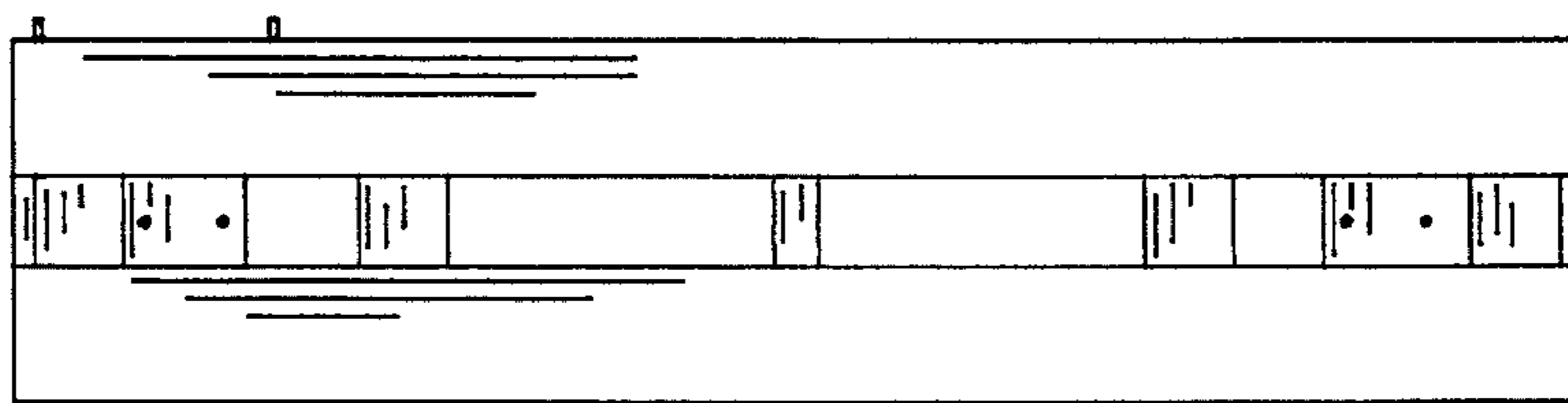

Fig. 3

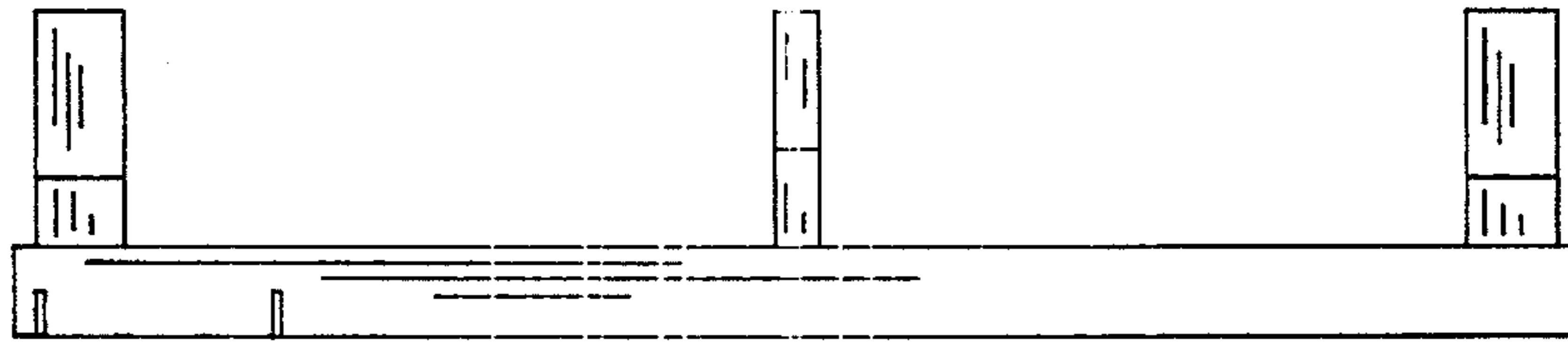

Fig. 4

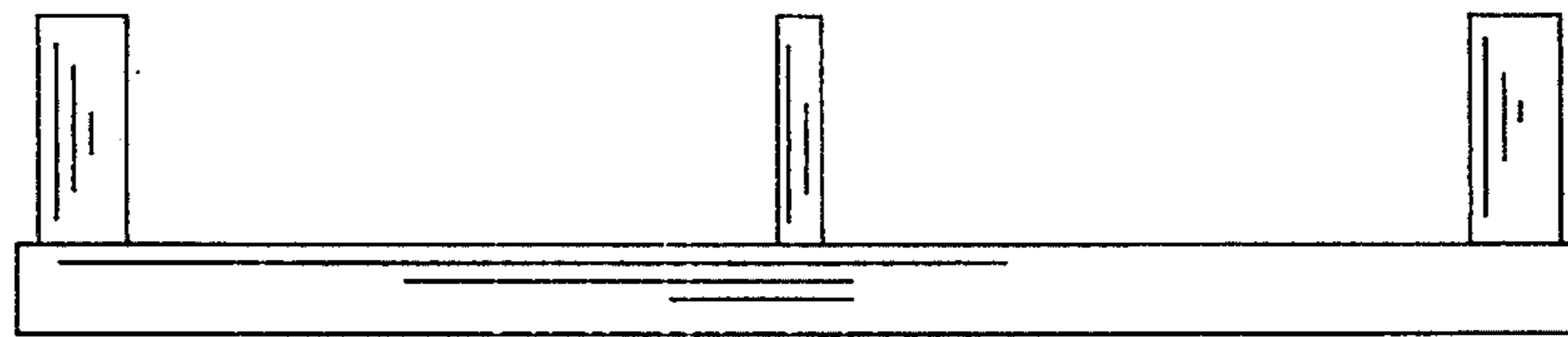

Fig. 5

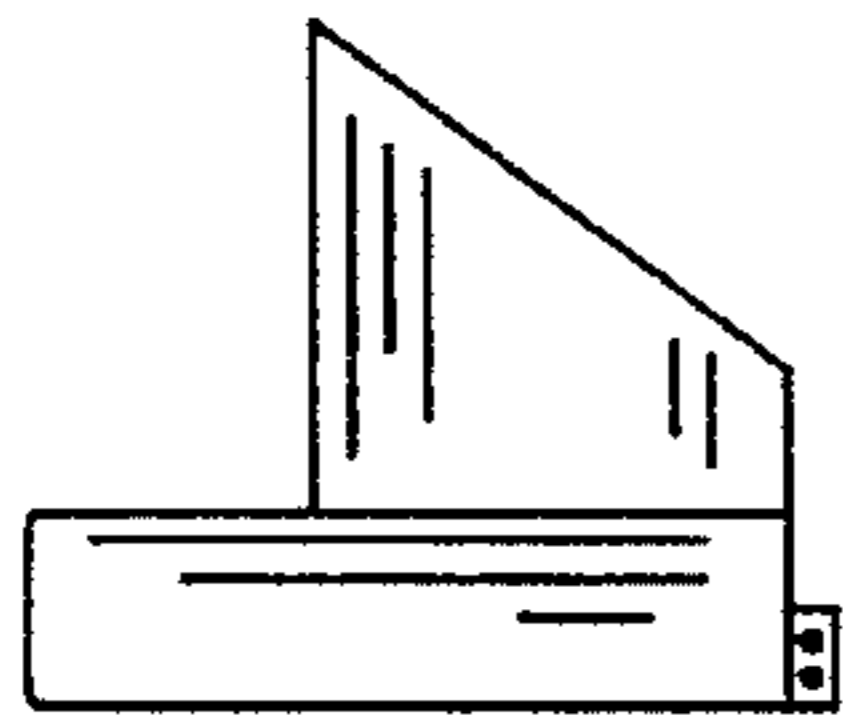

Fig. 6

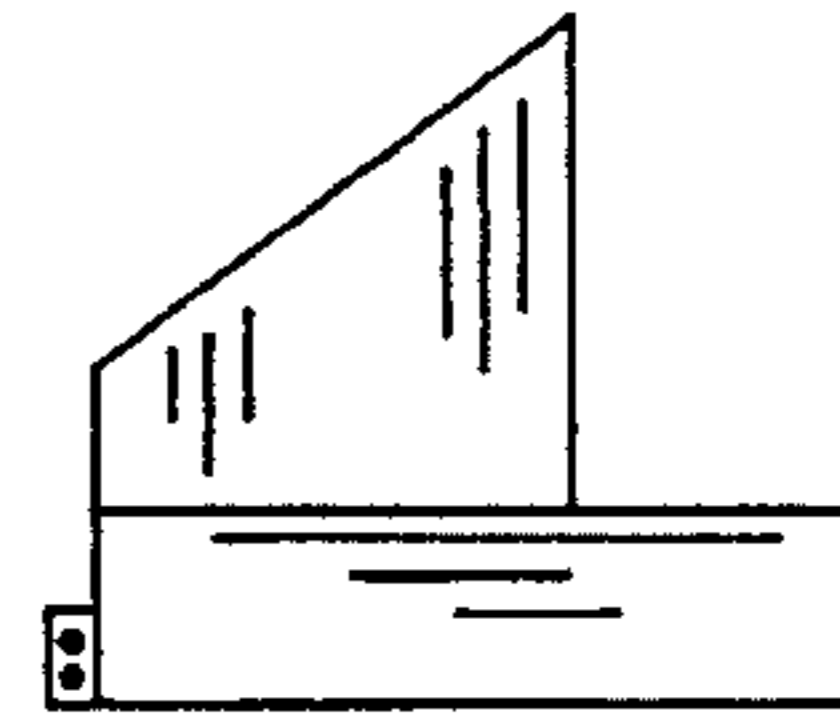

Fig. 7