



US00D370366S

United States Patent [19]

[11] **Patent Number: Des. 370,366**

Watts

[45] **Date of Patent: **Jun. 4, 1996**

[54] PULL-OUT SHELF ASSEMBLY

[76] Inventor: **Malcolm Watts**, P.O. Box 218, Mount Compass South, Australia, 5210

[**] Term: **14 Years**

[21] Appl. No.: **18,414**

[22] Filed: **Feb. 4, 1994**

[52] U.S. Cl. **D6/449**

[58] Field of Search D6/449, 450, 451, D6/474-479; 211/134, 151, 162; 312/196, 204

[56] **References Cited**

U.S. PATENT DOCUMENTS

| | | | |
|------------|---------|---------------------|----------|
| 128,439 | 6/1872 | Unna | 312/204 |
| D. 258,791 | 4/1981 | Verdesca | D6/479 |
| D. 285,632 | 9/1986 | Axhamre | D6/474 |
| D. 290,913 | 7/1987 | Righter | D6/479 X |
| D. 298,493 | 11/1988 | Hatcher et al. | D6/474 |

Primary Examiner—Nelson C. Holtje
Assistant Examiner—S. Snapp
Attorney, Agent, or Firm—R. K. Maddern and Ass.

[57] **CLAIM**

The ornamental design for a pull-out shelf assembly, as shown and described.

DESCRIPTION

FIG. 1 is a perspective view of a pull-out shelf assembly showing my new design with the shelf in an extended position;

FIG. 2 is a side elevation taken from the left of FIG. 1, the opposite elevation being a mirror image thereof;

FIG. 3 is a front elevation;

FIG. 4 is a rear elevation;

FIG. 5 is a top plan view; and,

FIG. 6 is a bottom plan view.

1 Claim, 3 Drawing Sheets

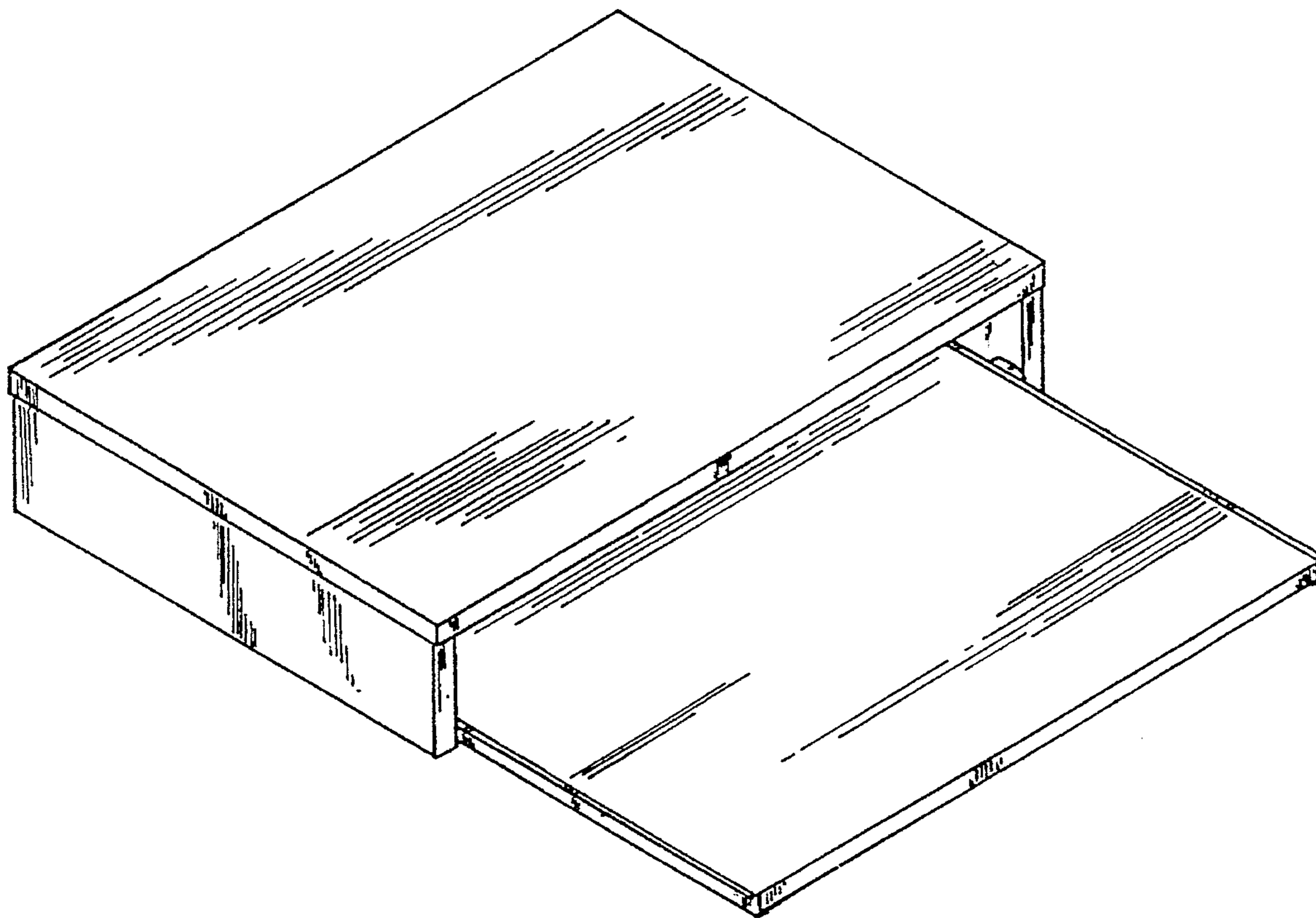

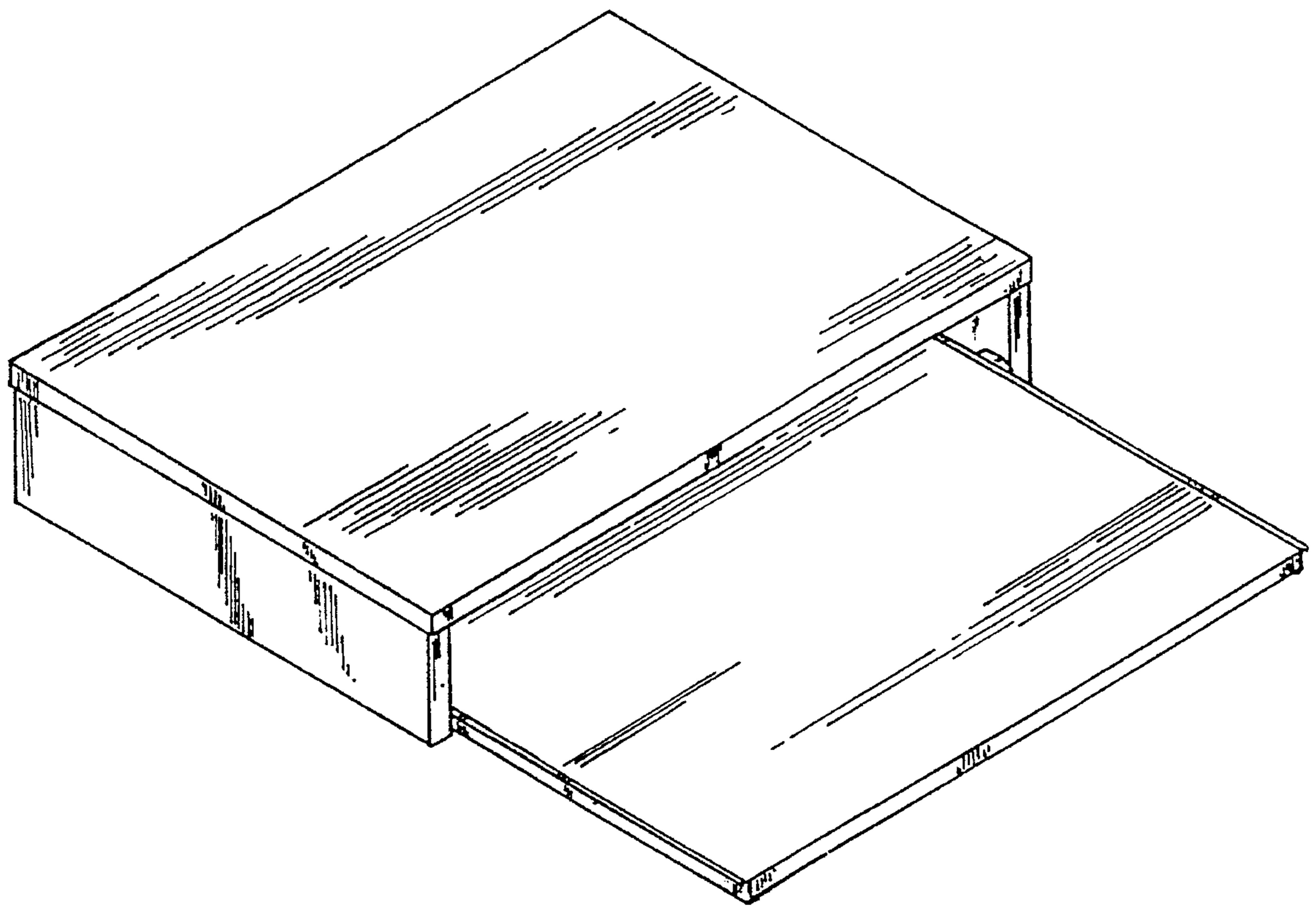

Figure 1

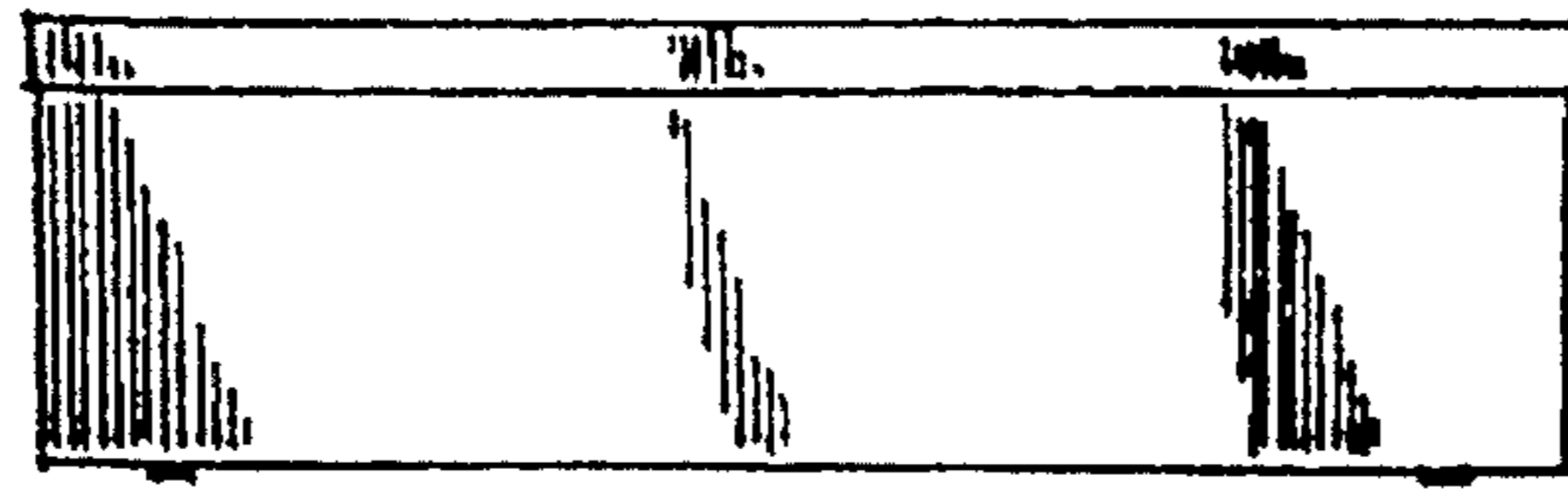

Figure 2

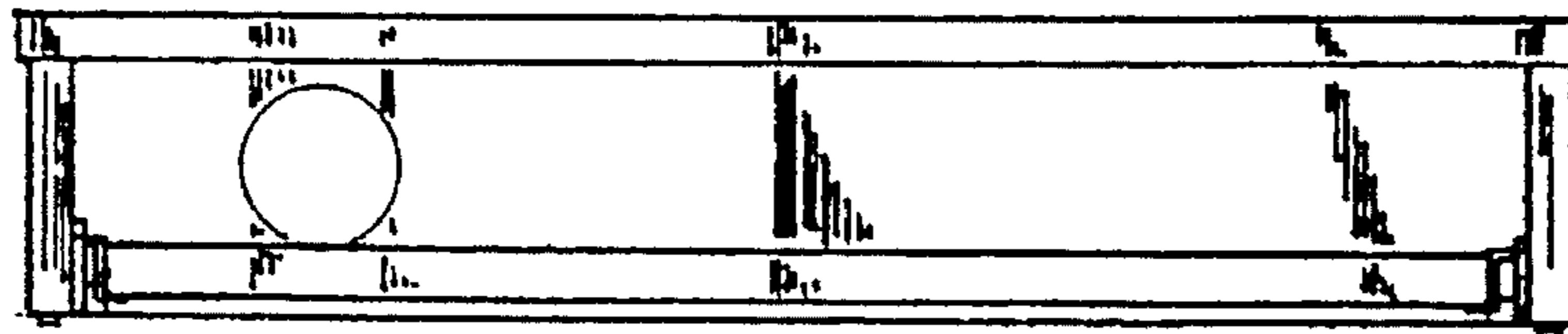

Figure 3

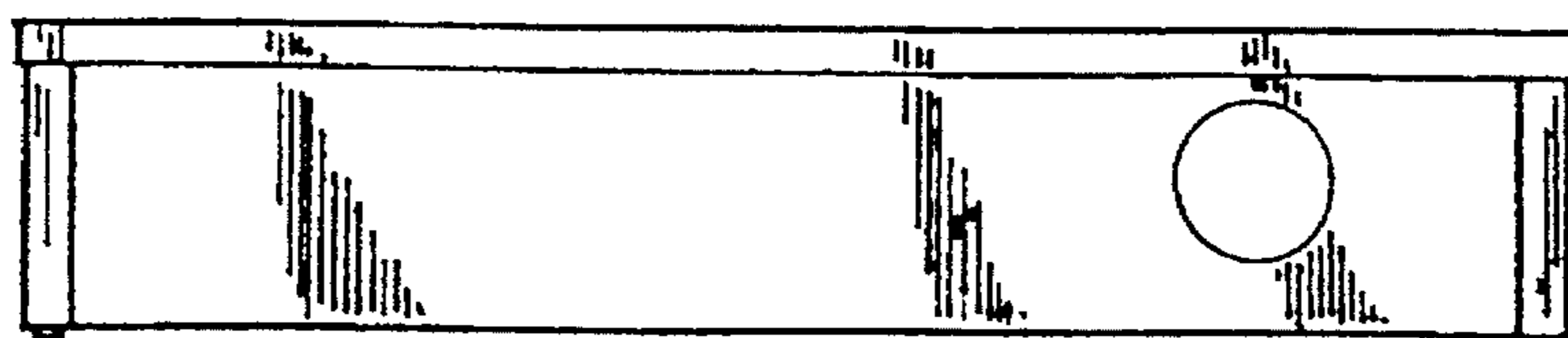

Figure 4

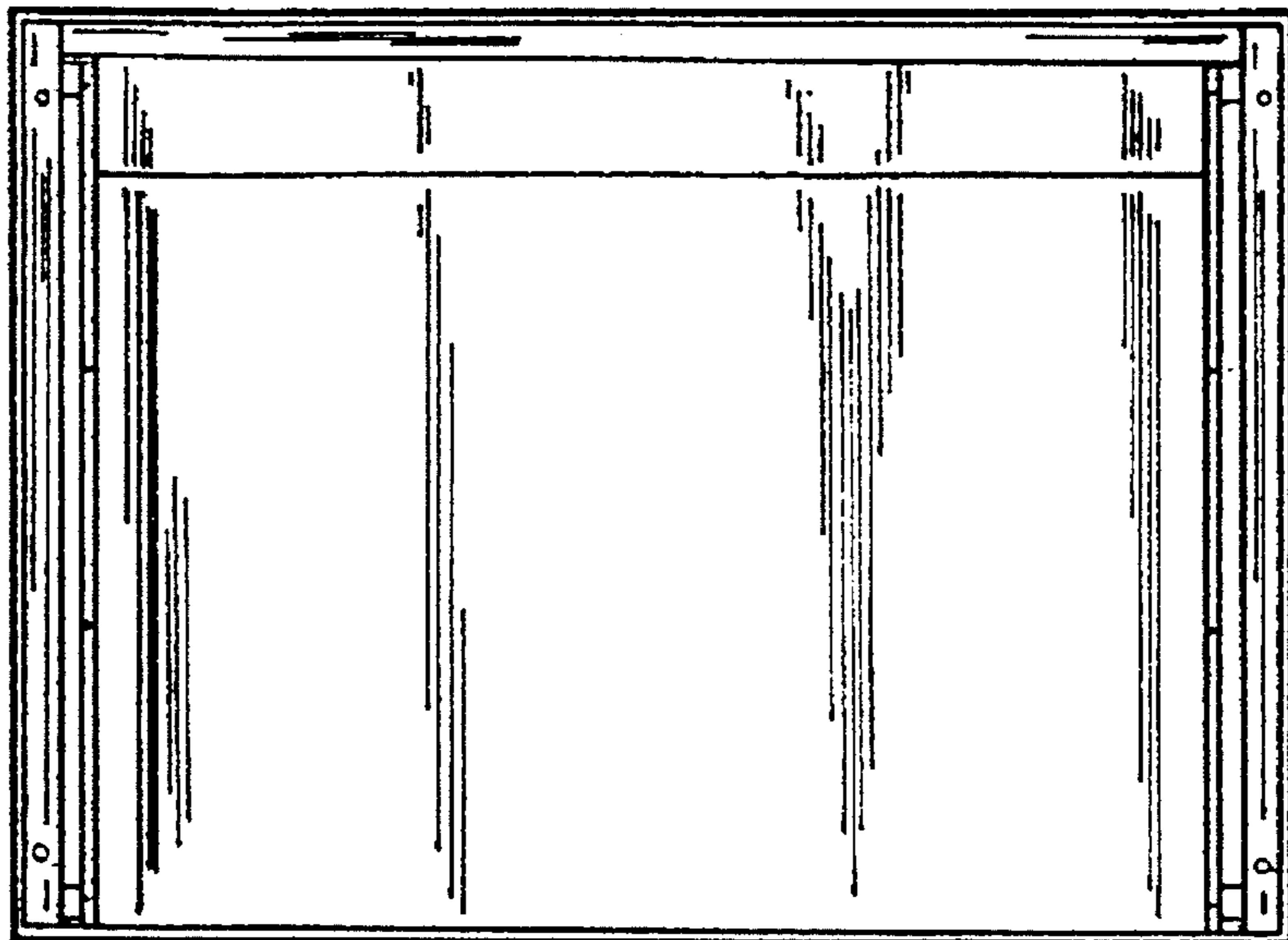

Figure 6

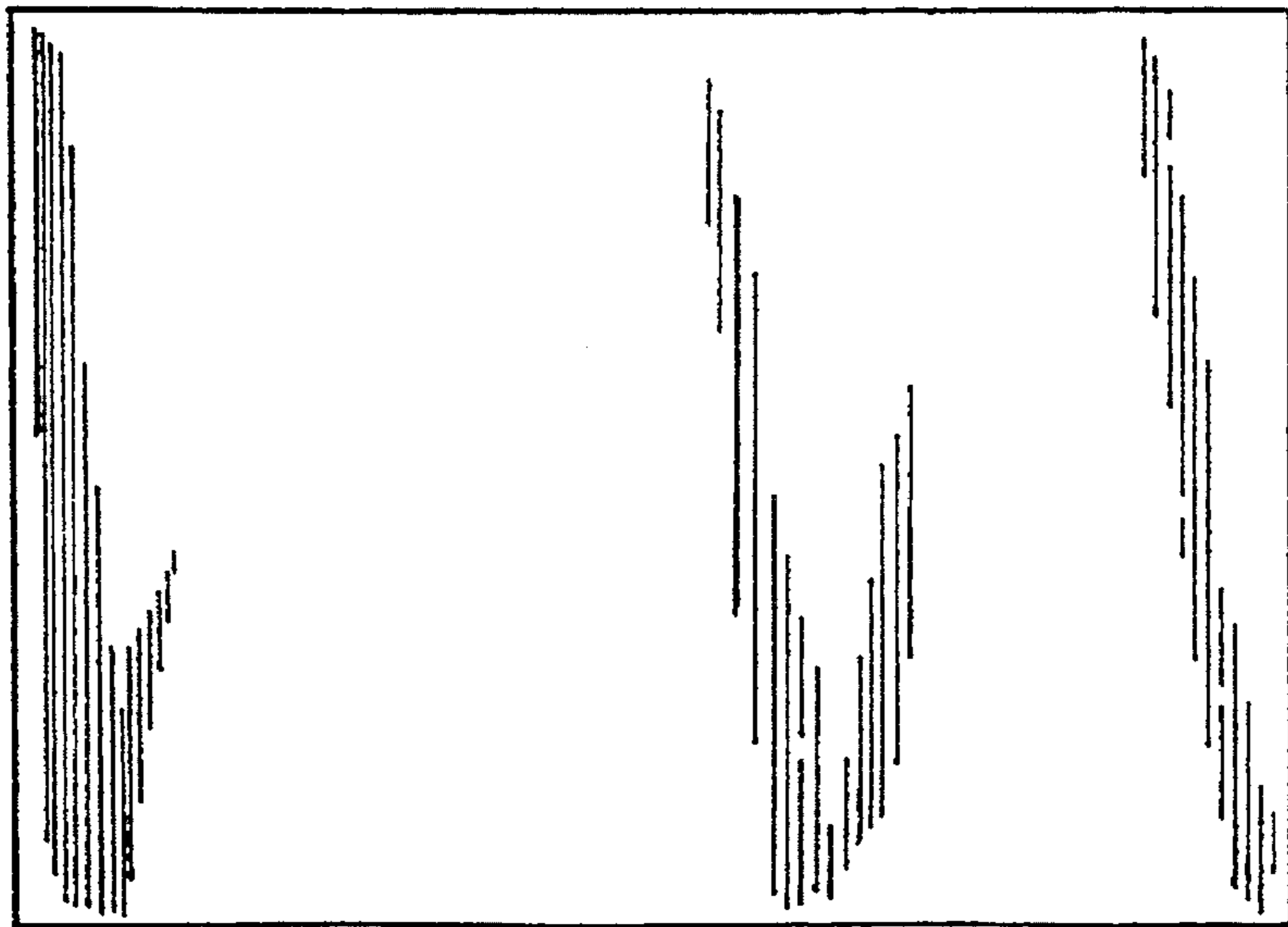

Figure 5