



US00D370309S

United States Patent [19]
Stucky

[11] **Patent Number: Des. 370,309**

[45] **Date of Patent: **May 28, 1996**

[54] **SAFETY HEADGUARD**

4,766,610 8/1988 Mattes 2/414
5,075,903 12/1991 Richoux 2/411

[76] Inventor: **Carla A. Stucky**, 5833 Bittersweet Dr.,
West Lafayette, Ind. 47906

Primary Examiner—Ruth McInroy
Attorney, Agent, or Firm—William Brinks Hofer Gilson &
Lione

[**] Term: **14 Years**

[21] Appl. No.: **30,658**

[57] **CLAIM**

[22] Filed: **Nov. 4, 1994**

The ornamental design for a safety headguard, as shown and
described.

[52] U.S. Cl. **D29/102**

[58] Field of Search D29/102, 105-108,
D29/111-112; 2/410-412, 414, 423-425,
9, 10

DESCRIPTION

FIG. 1 is a perspective view of a safety headguard showing
my new design;
FIG. 2 is a side elevational view thereof;
FIG. 3 is a front elevational view thereof;
FIG. 4 is a rear elevational view thereof;
FIG. 5 is a top plan view thereof;
FIG. 6 is a bottom plan view thereof;
FIG. 7 is a side elevational view of a second embodiment
thereof, the only difference being the addition of two straps
on the rear portion of the headguard; and,
FIG. 8 is a rear elevational view thereof.
The person shown in broken lines in FIG. 1 is shown for
illustrative purposes only and forms no part of the claimed
design.

[56] **References Cited**

U.S. PATENT DOCUMENTS

D. 330,271	10/1992	Samples	D29/102
2,546,842	3/1951	Yealdhall	2/3
3,327,316	6/1967	Pukish, Jr.	D29/112
3,628,191	12/1971	Douglas	D29/106
3,953,892	5/1976	Kennedy et al.	2/3 R
4,062,067	12/1977	Franzen	2/410
4,443,891	4/1984	Blomgren et al.	2/414
4,612,672	9/1986	Schrack	D29/105
4,613,993	9/1986	Steele et al.	2/411
4,675,919	6/1987	Heine et al.	2/410
4,698,852	10/1987	Romero	2/171
4,736,469	4/1988	Boretti	D29/102

1 Claim, 2 Drawing Sheets

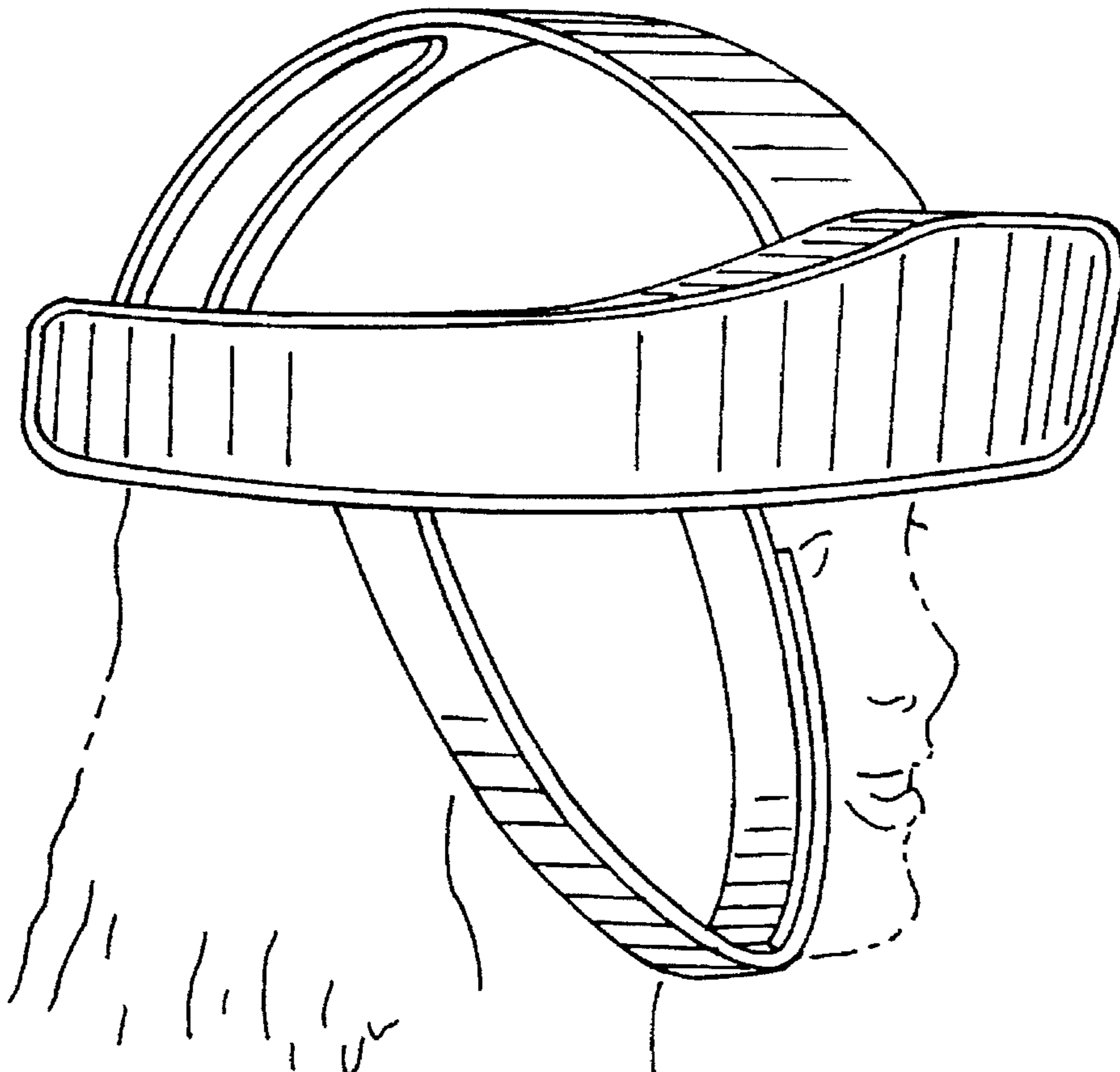

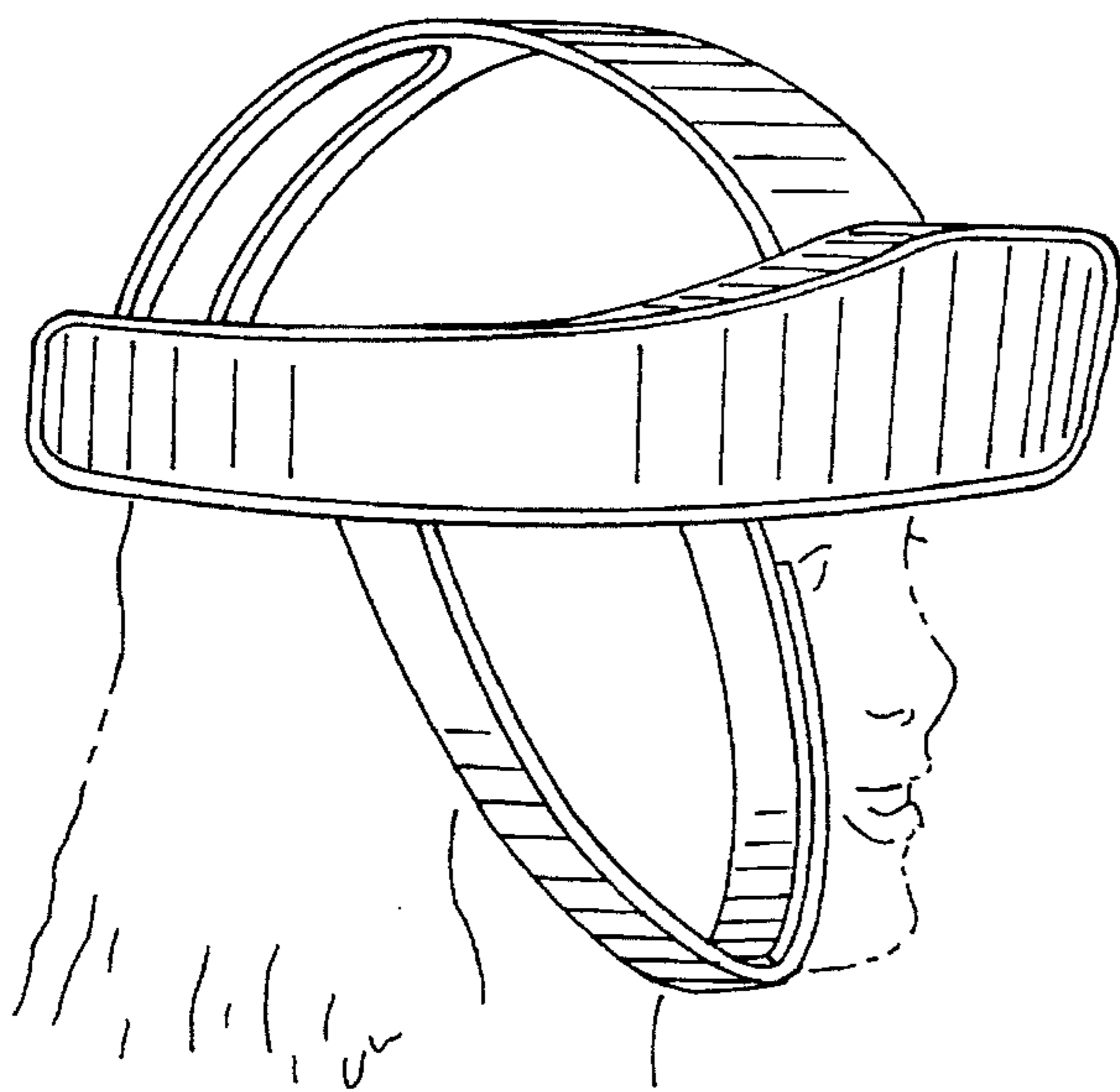

FIG. 1

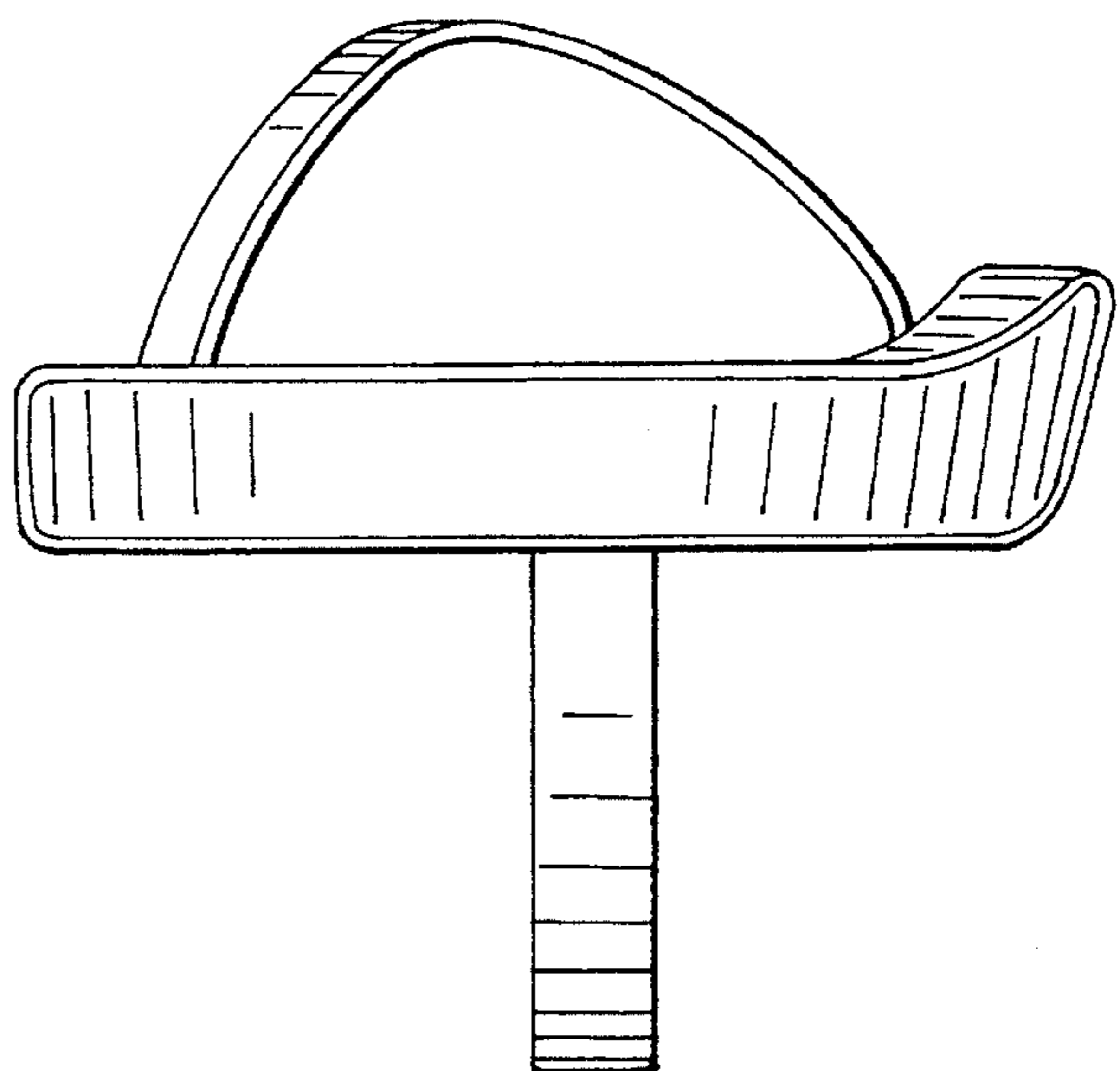

FIG. 2

FIG. 3

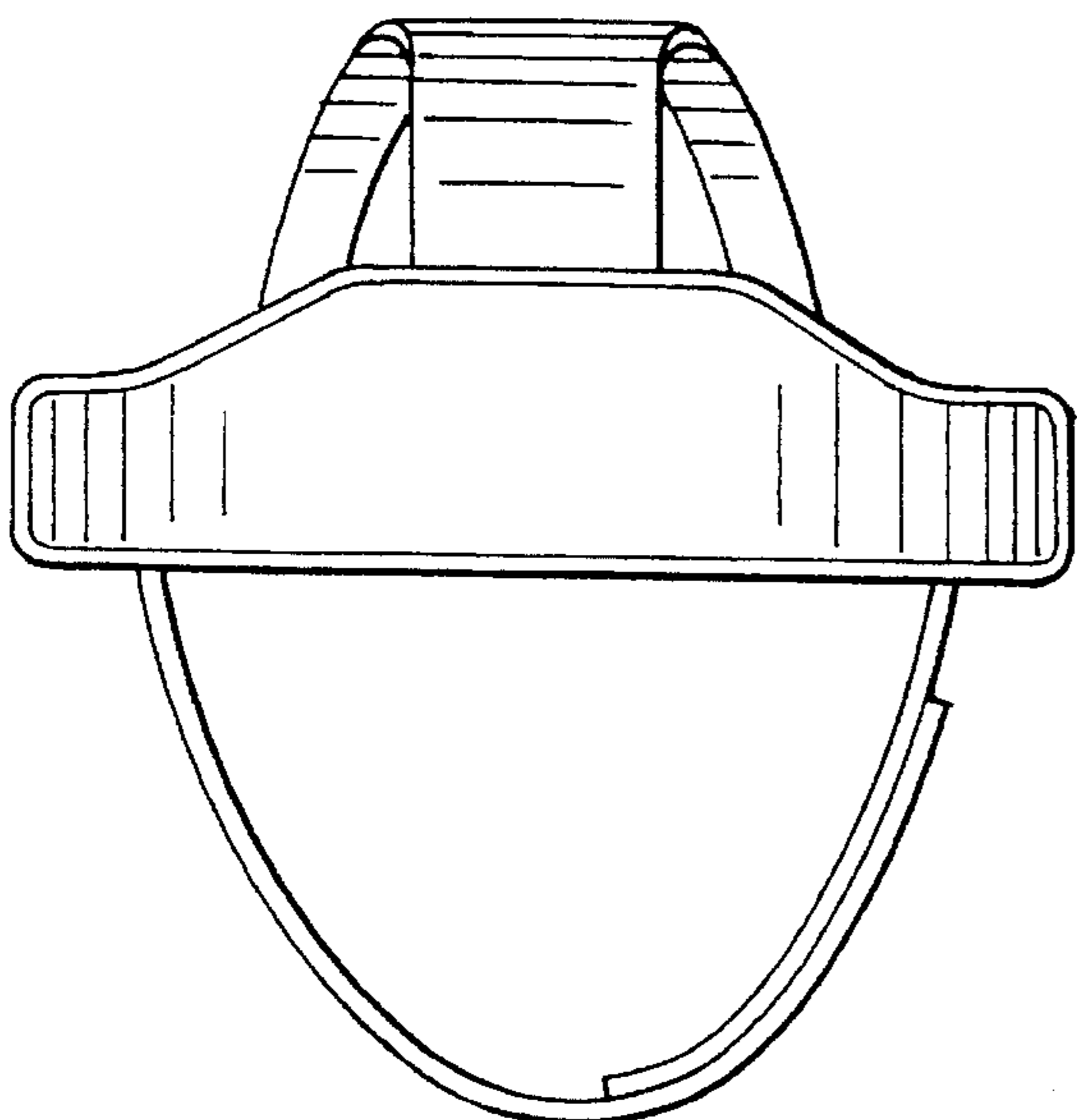
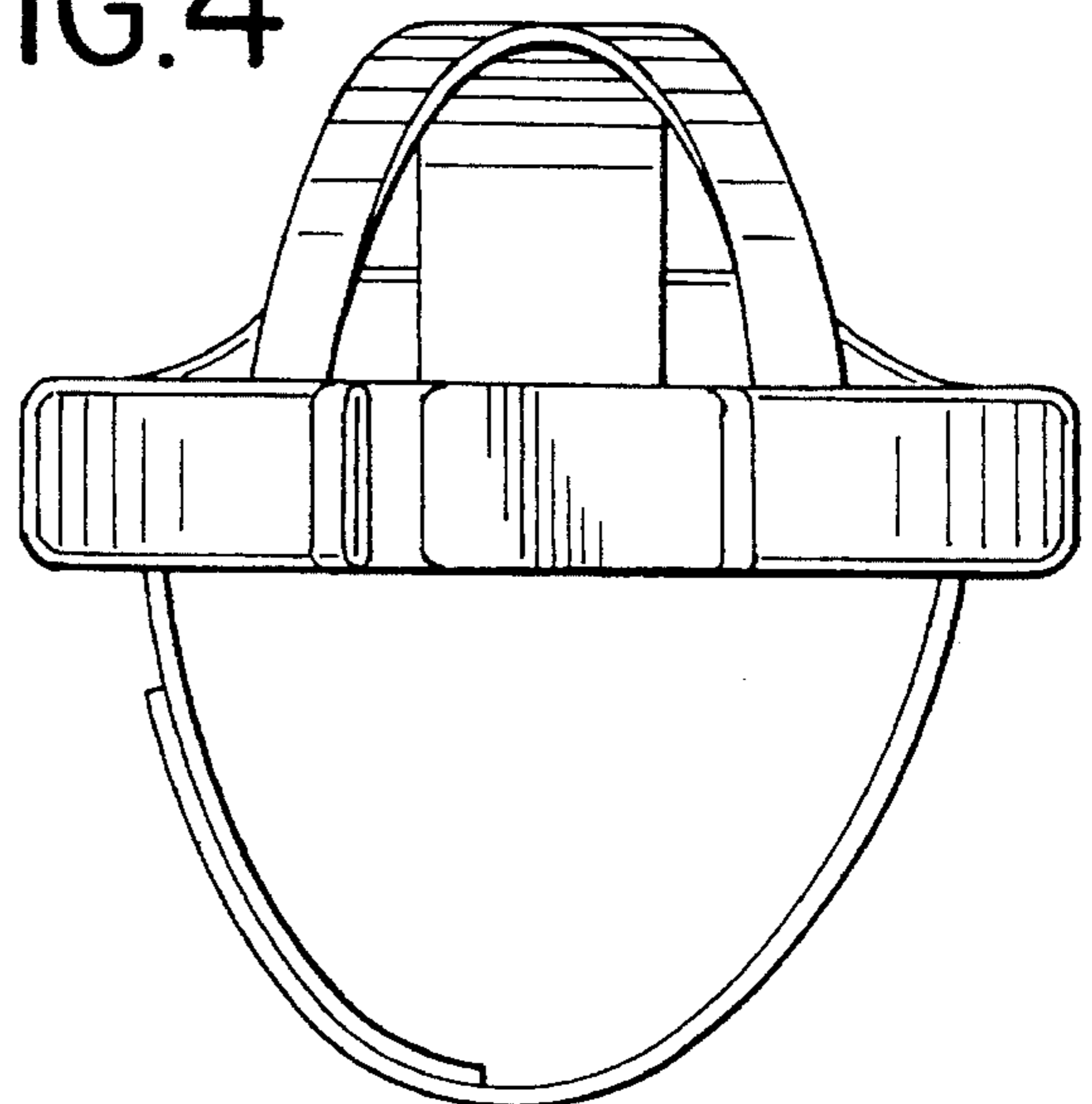

FIG. 4



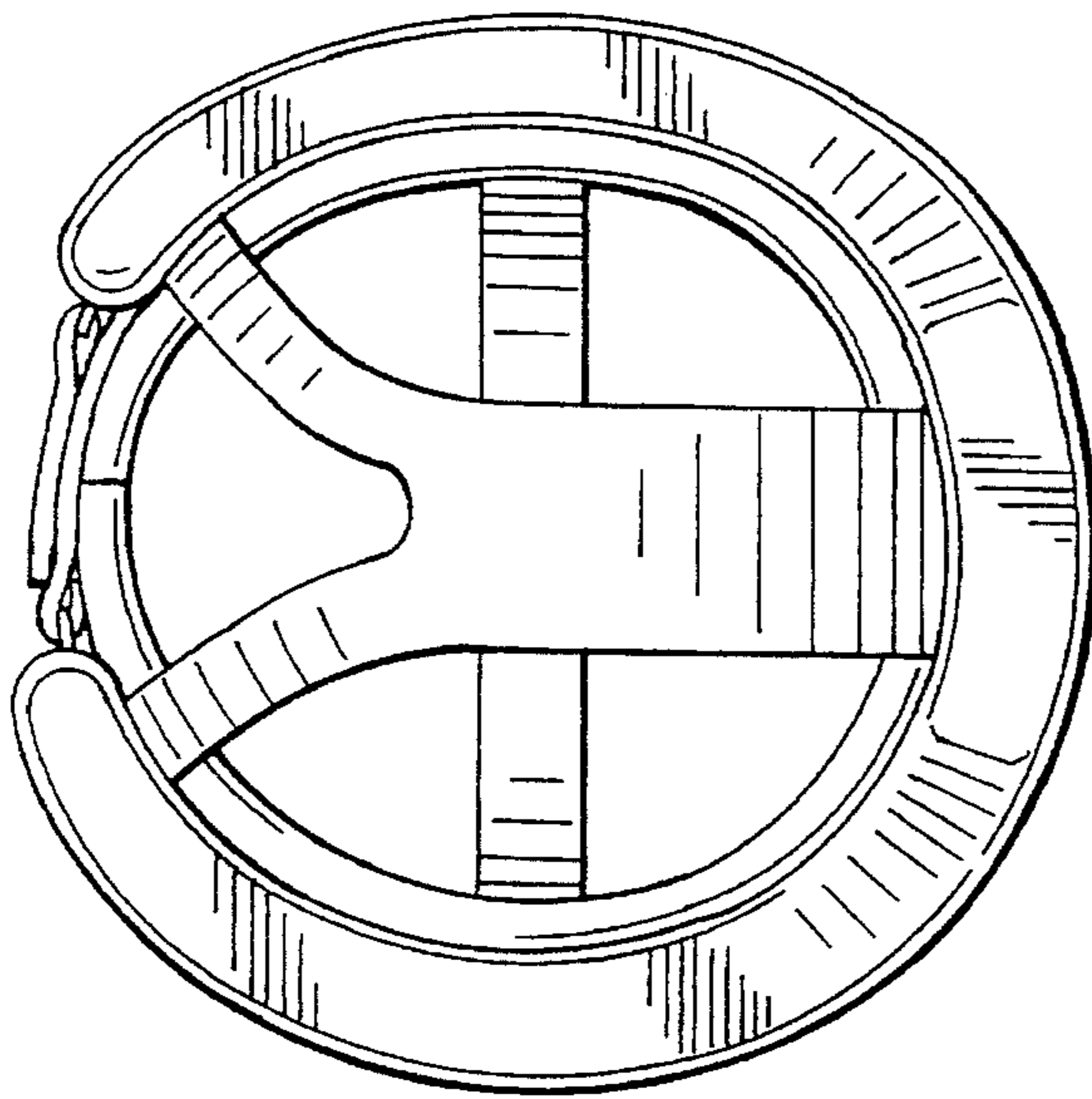

FIG. 5

FIG. 6

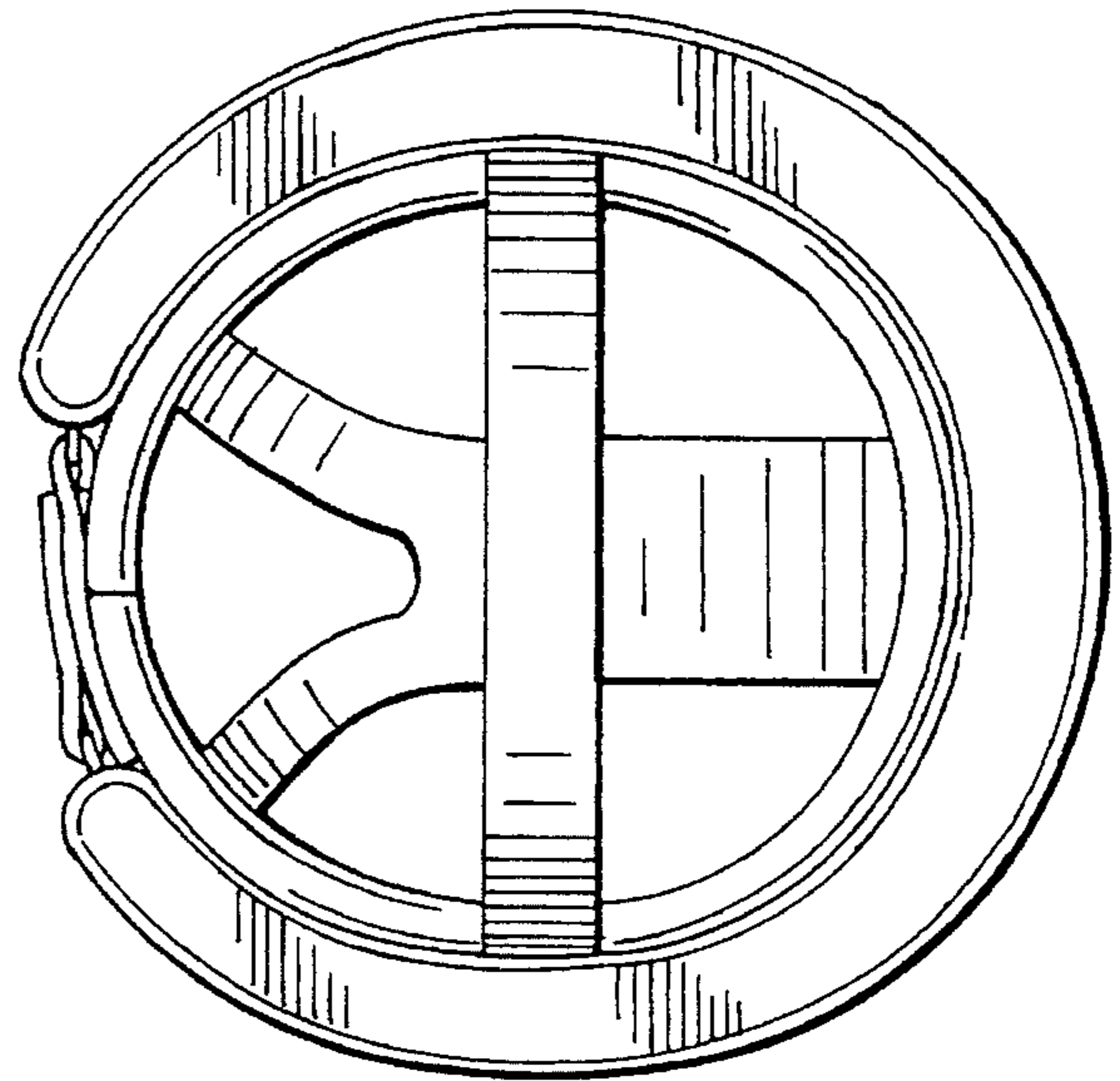

FIG. 7

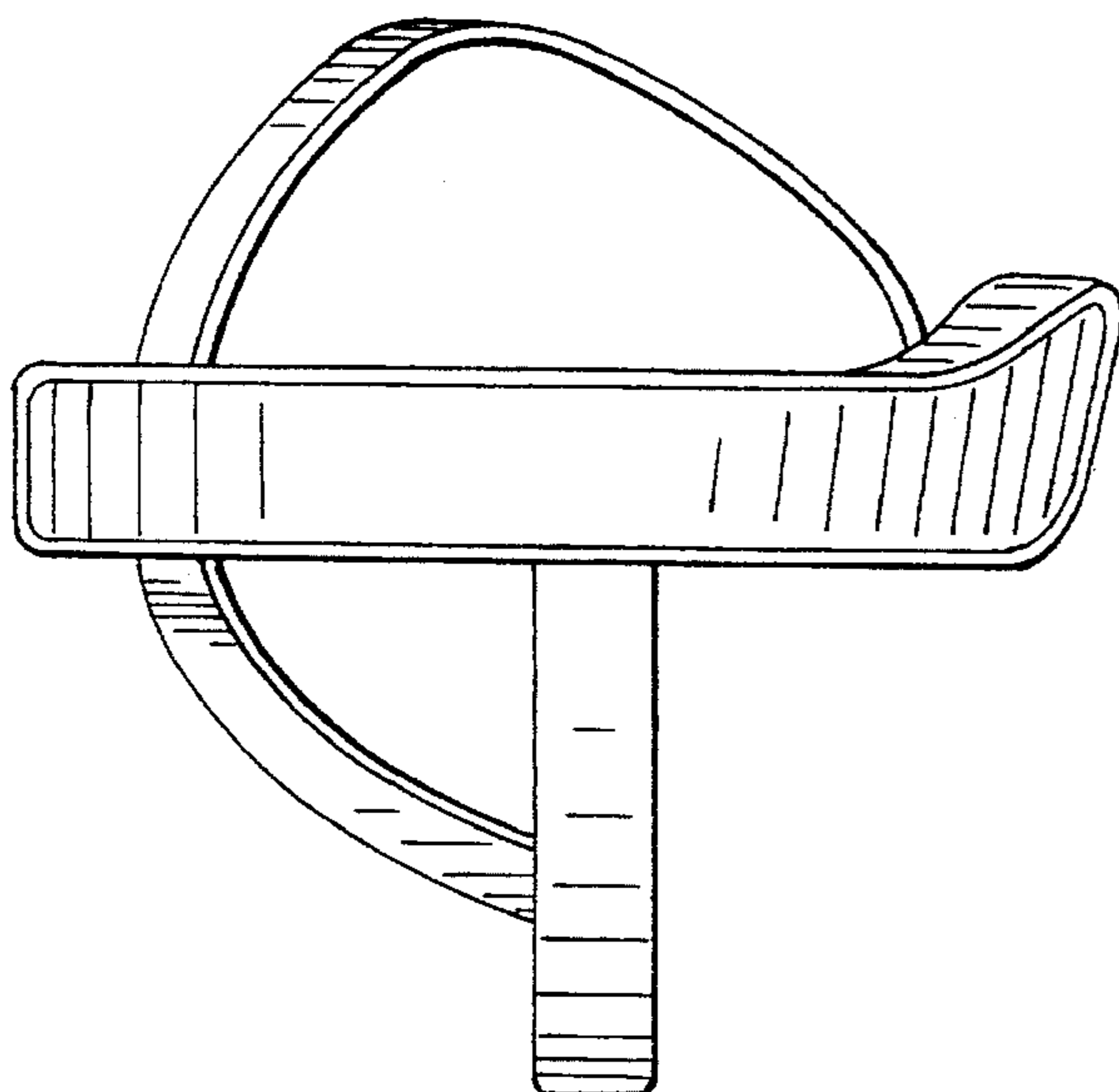

FIG. 8

