



US00D370171S

United States Patent [19]
Emerson

[11] **Patent Number: Des. 370,171**
[45] **Date of Patent: **May 28, 1996**

[54] **TRAILER HITCH BRACKET**

[76] Inventor: **Jeffrey T. Emerson**, 7853 Hickory St.
NE., Minneapolis, Minn. 55432

[**] Term: **14 Years**

[21] Appl. No.: **32,739**

[22] Filed: **Dec. 27, 1994**

[52] U.S. Cl. **D8/354**

[58] **Field of Search** D8/349, 354; 280/490.1,
280/423; D12/223, 106; 248/536, 539,
300, 214

[56] **References Cited**

U.S. PATENT DOCUMENTS

D. 244,748	6/1977	Canterbury	D8/380
D. 296,075	6/1988	Jones	D8/373
3,035,856	5/1962	Mleczko et al. .	
3,123,382	3/1964	Toland	280/490.1
3,201,073	8/1965	Buescher et al.	248/300 X
3,326,576	6/1967	Kothmann .	
3,625,545	12/1971	Somers et al. .	
3,700,254	10/1972	Eck .	
4,046,398	9/1977	Dunwoody .	
4,248,451	2/1981	Usinger .	
4,514,132	4/1985	Law et al. .	
5,354,087	10/1994	Head .	

OTHER PUBLICATIONS

Sweets catalog—Hughes Manufacturing, Inc. 06060/Hug,
1993, no page number, plate anchor located at bottom right
corner of page.

Primary Examiner—A. Hugo Word

Assistant Examiner—Holly Baynham

Attorney, Agent, or Firm—Burd, Bartz & Gutenkauf

[57] **CLAIM**

The ornamental design for a trailer hitch bracket, as shown
and described.

DESCRIPTION

FIG. 1 is a perspective view showing the trailer hitch bracket
of my new design;

FIG. 2 is an end elevational view thereof, the opposite end
being a mirror image thereof;

FIG. 3 is a side elevational view thereof, the opposite side
being a mirror image thereof;

FIG. 4 is a top plan view thereof;

FIG. 5 is a bottom plan view thereof;

FIG. 6 is a perspective view of a first modification of the
trailer hitch bracket of my new design;

FIG. 7 is an end elevational view of FIG. 6, the opposite end
being a mirror image thereof;

FIG. 8 is a side elevational view of FIG. 6, the opposite side
being a mirror image thereof;

FIG. 9 is a top plan view of FIG. 6;

FIG. 10 is a bottom plan view of FIG. 6;

FIG. 11 is a perspective view of a second modification of the
trailer hitch bracket showing my new design;

FIG. 12 is an end elevational view of FIG. 11, the opposite
end being a mirror image thereof;

FIG. 13 is a side elevational view of FIG. 11, the opposite
side being a mirror image thereof;

FIG. 14 is a top plan view of FIG. 11; and,

FIG. 15 is a bottom plan view of FIG. 11.

1 Claim, 3 Drawing Sheets

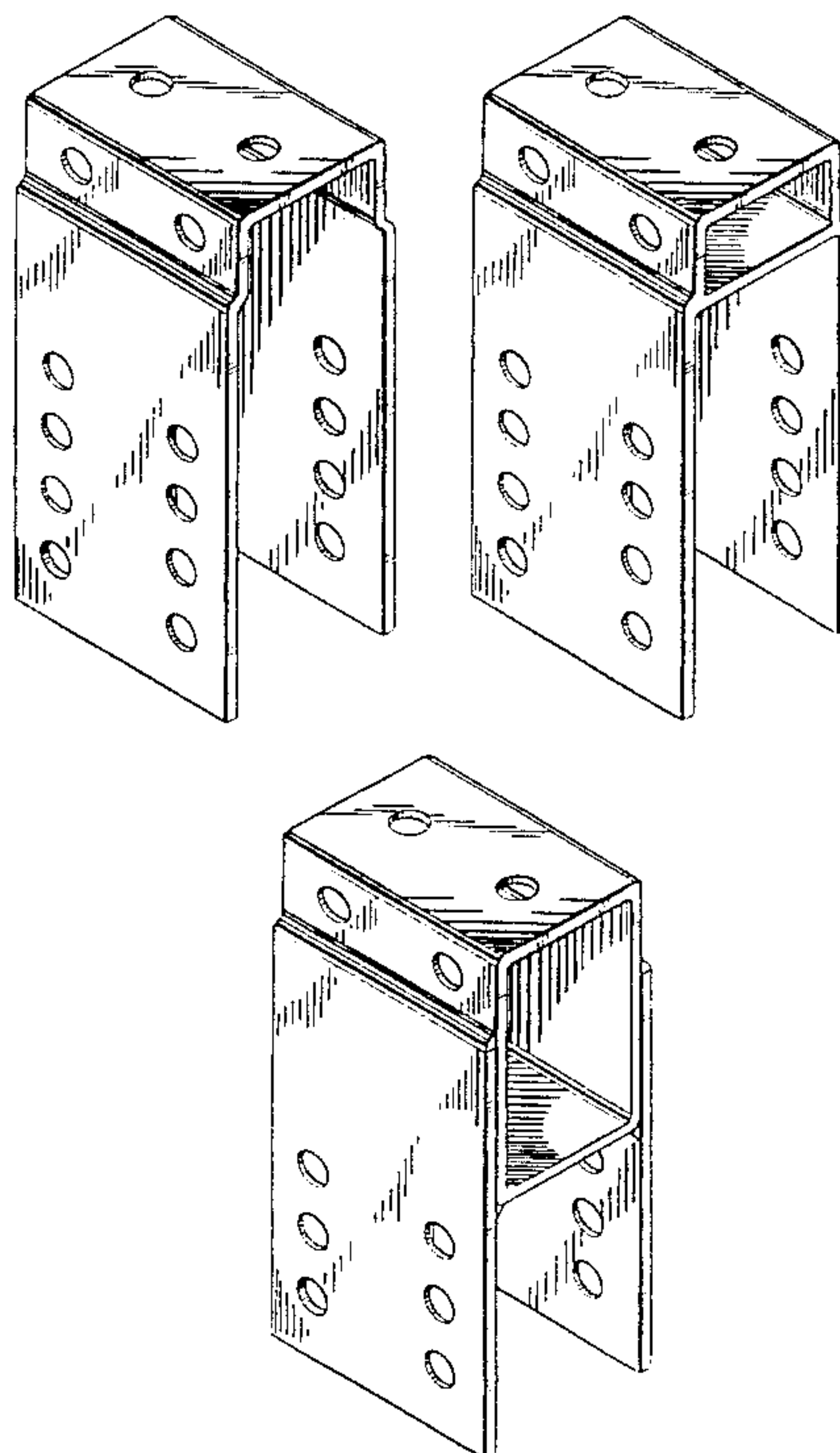

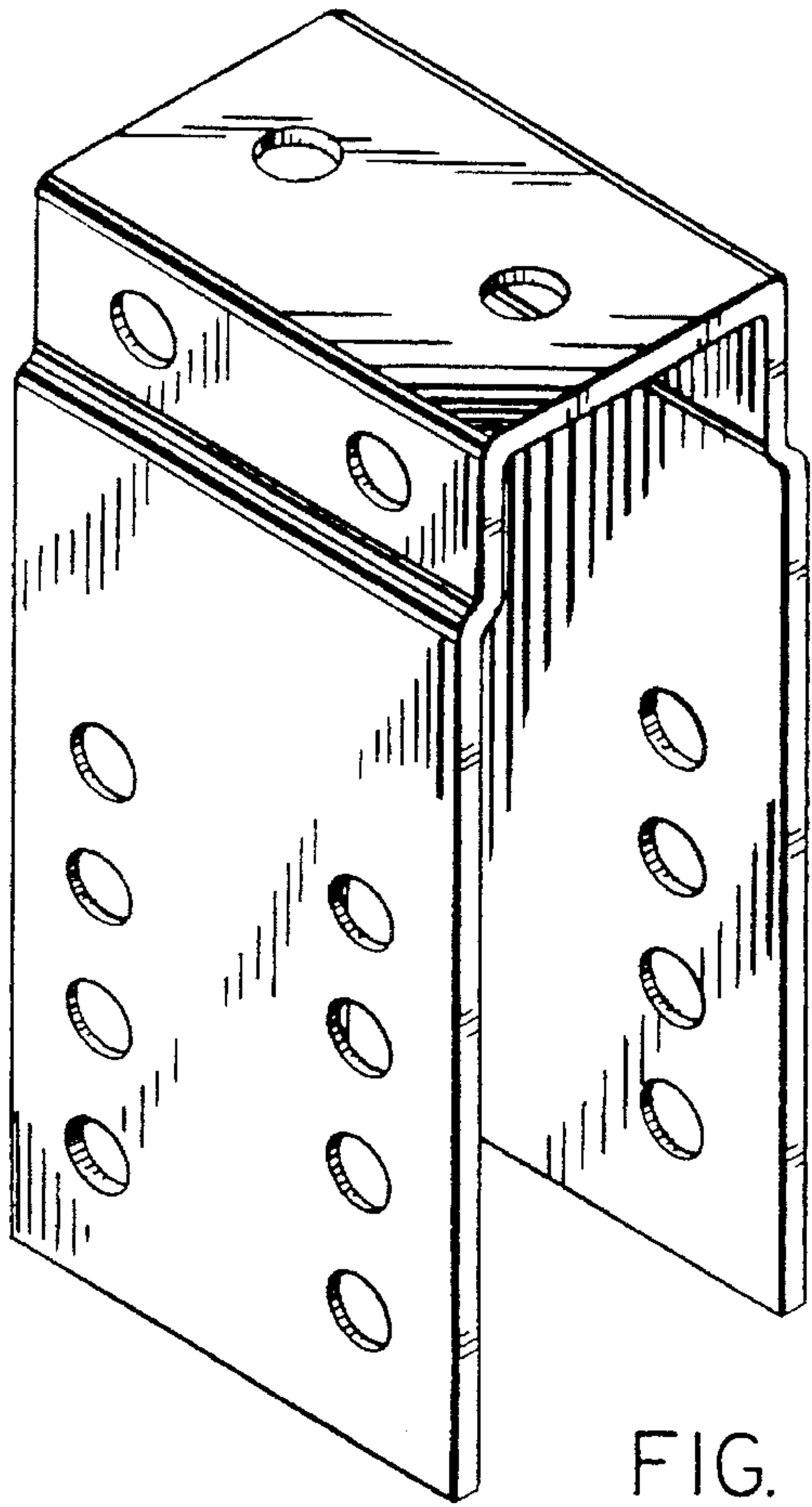

FIG. 1

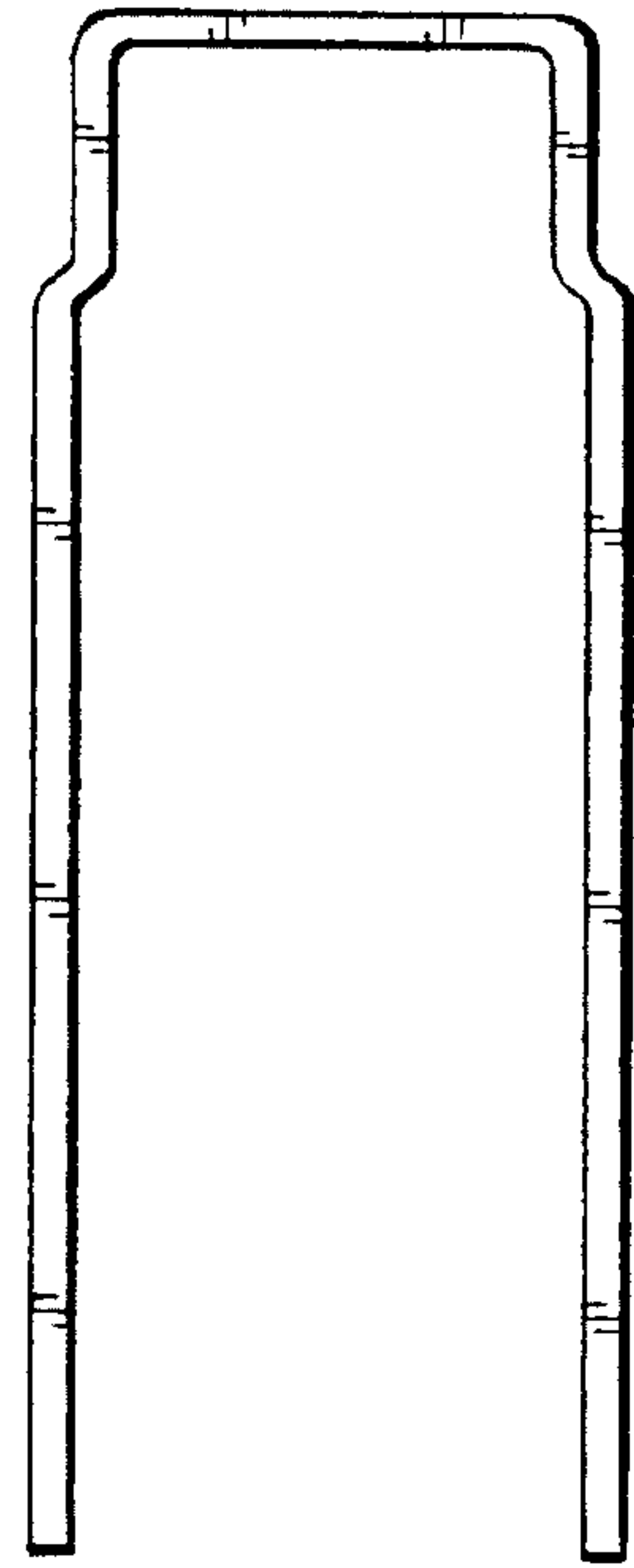

FIG. 2

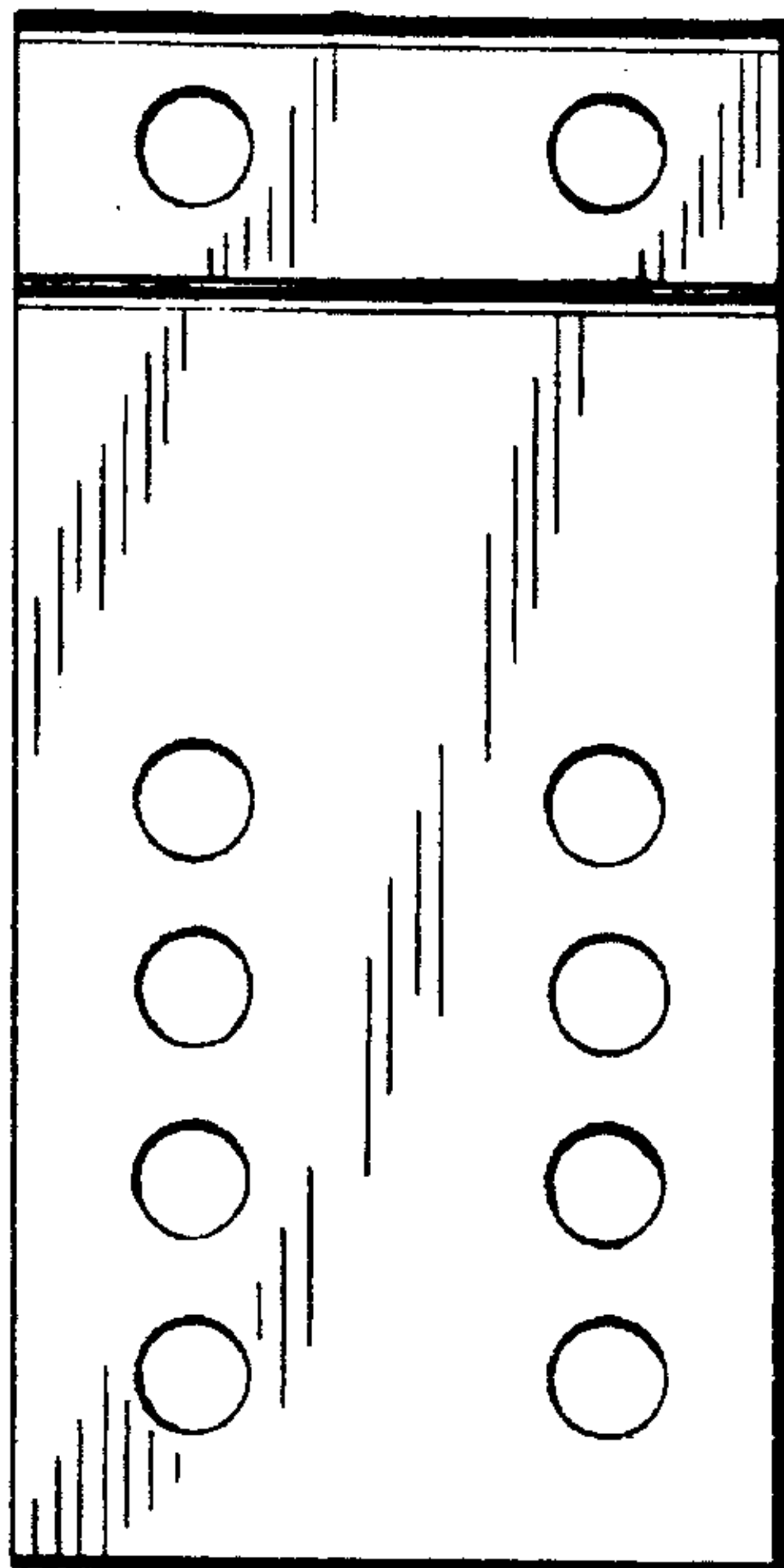

FIG. 3

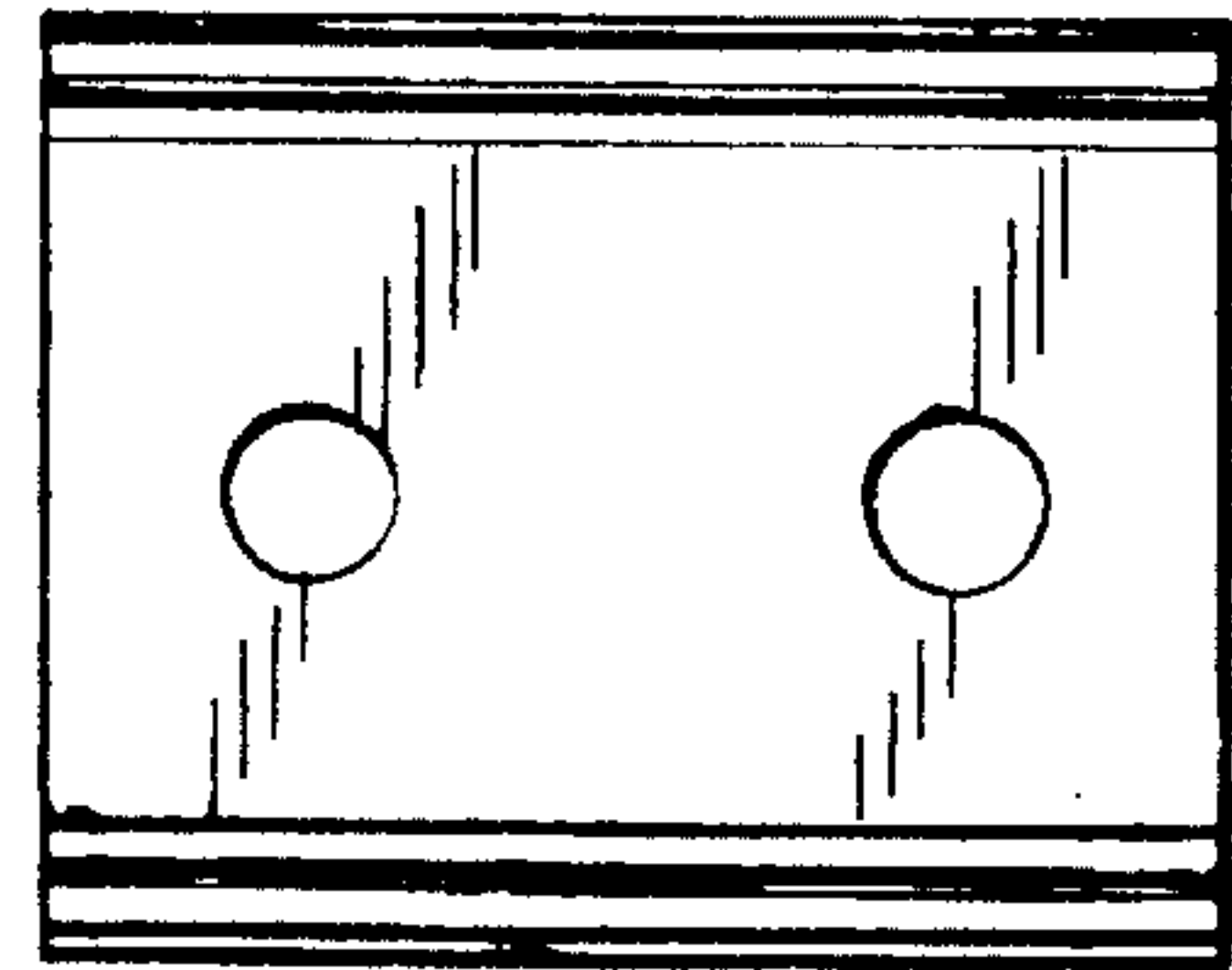

FIG. 4

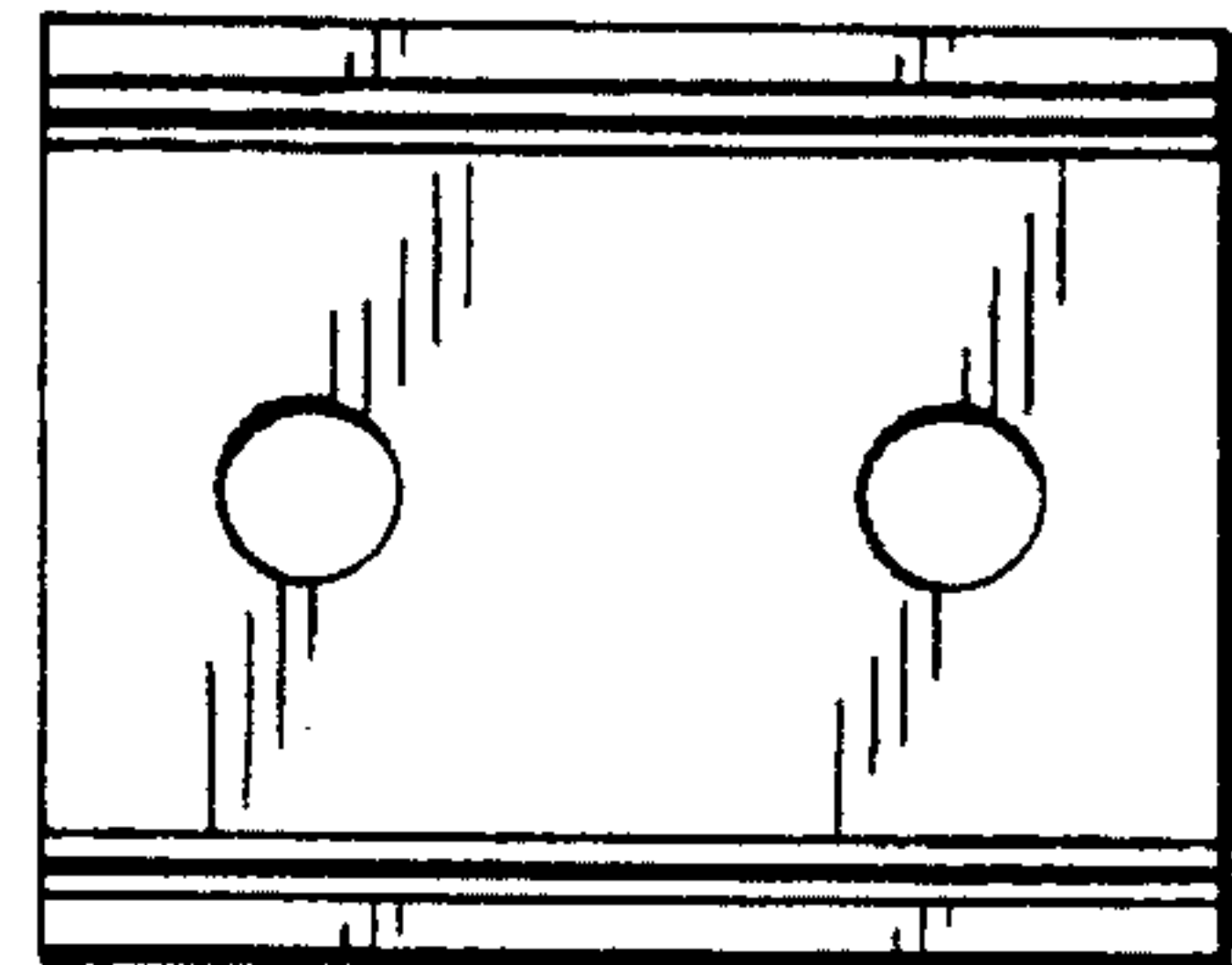

FIG. 5

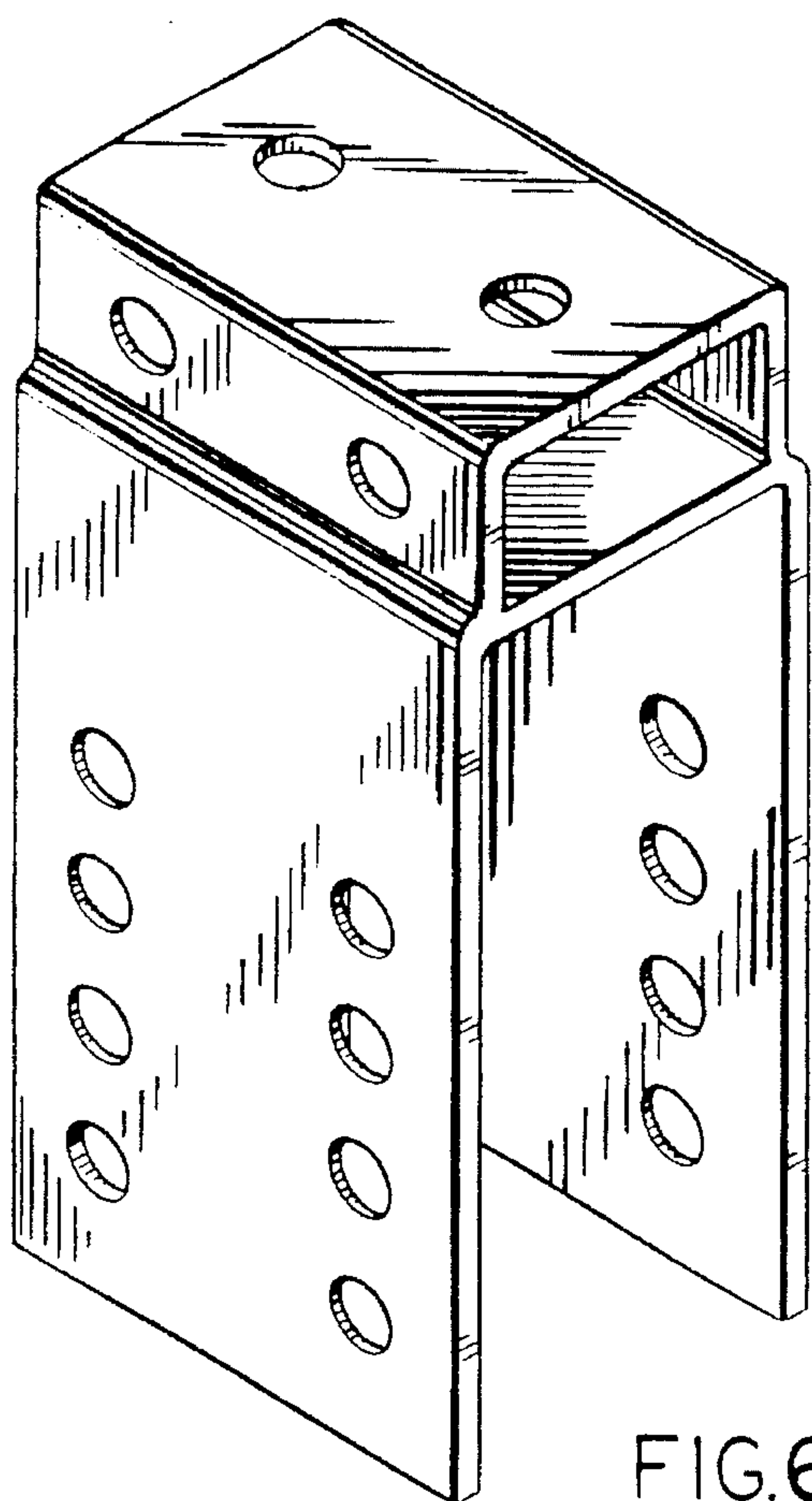

FIG. 6

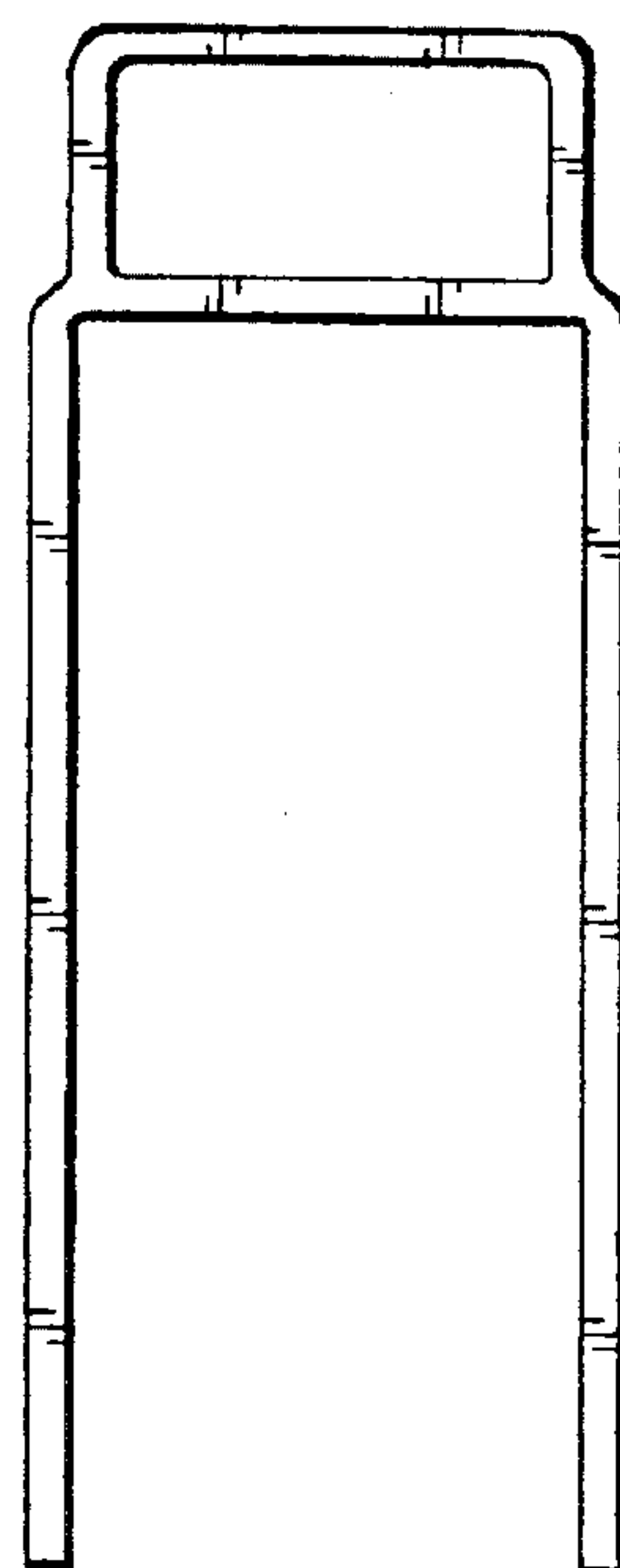

FIG. 7

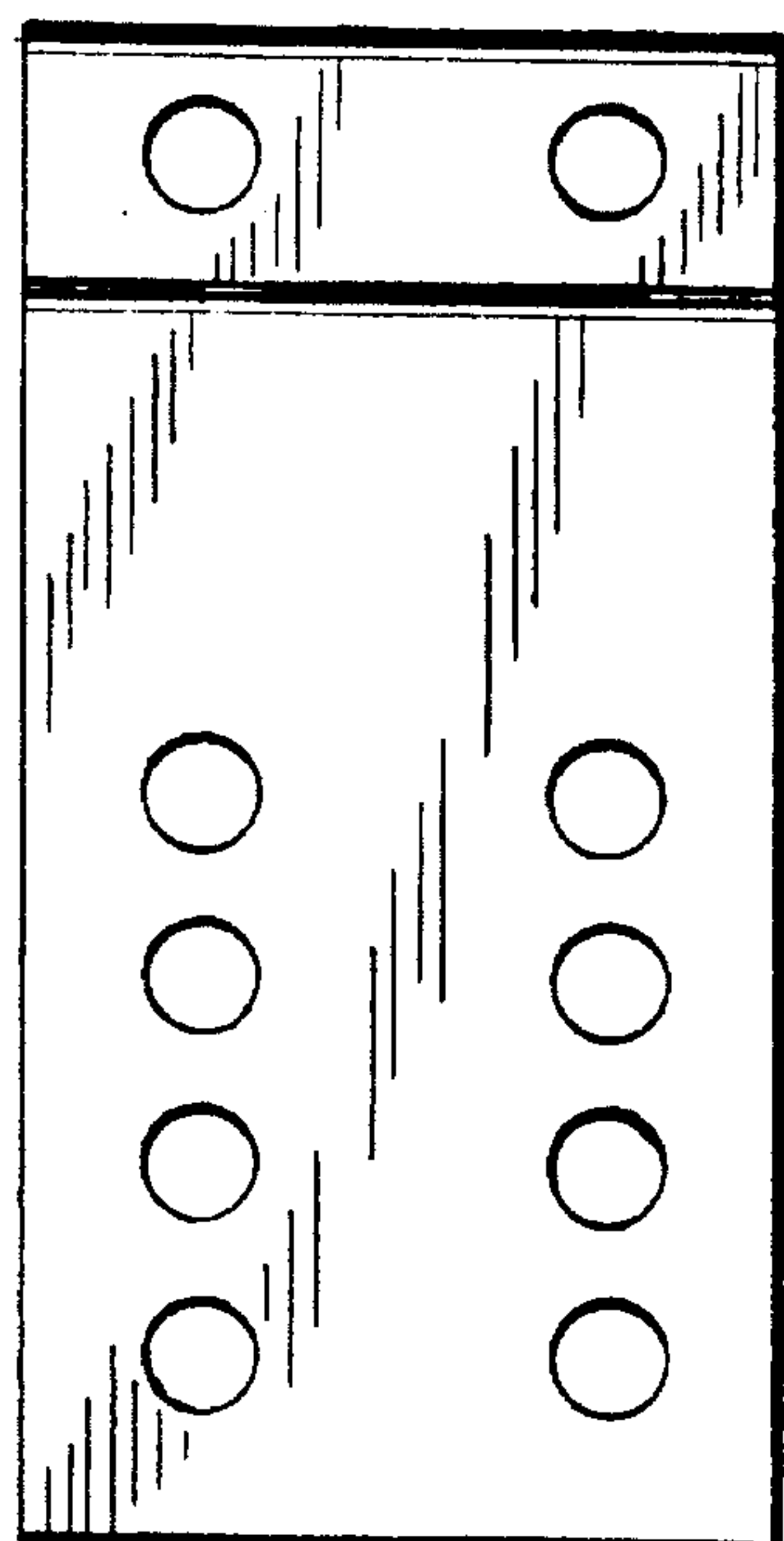

FIG. 8

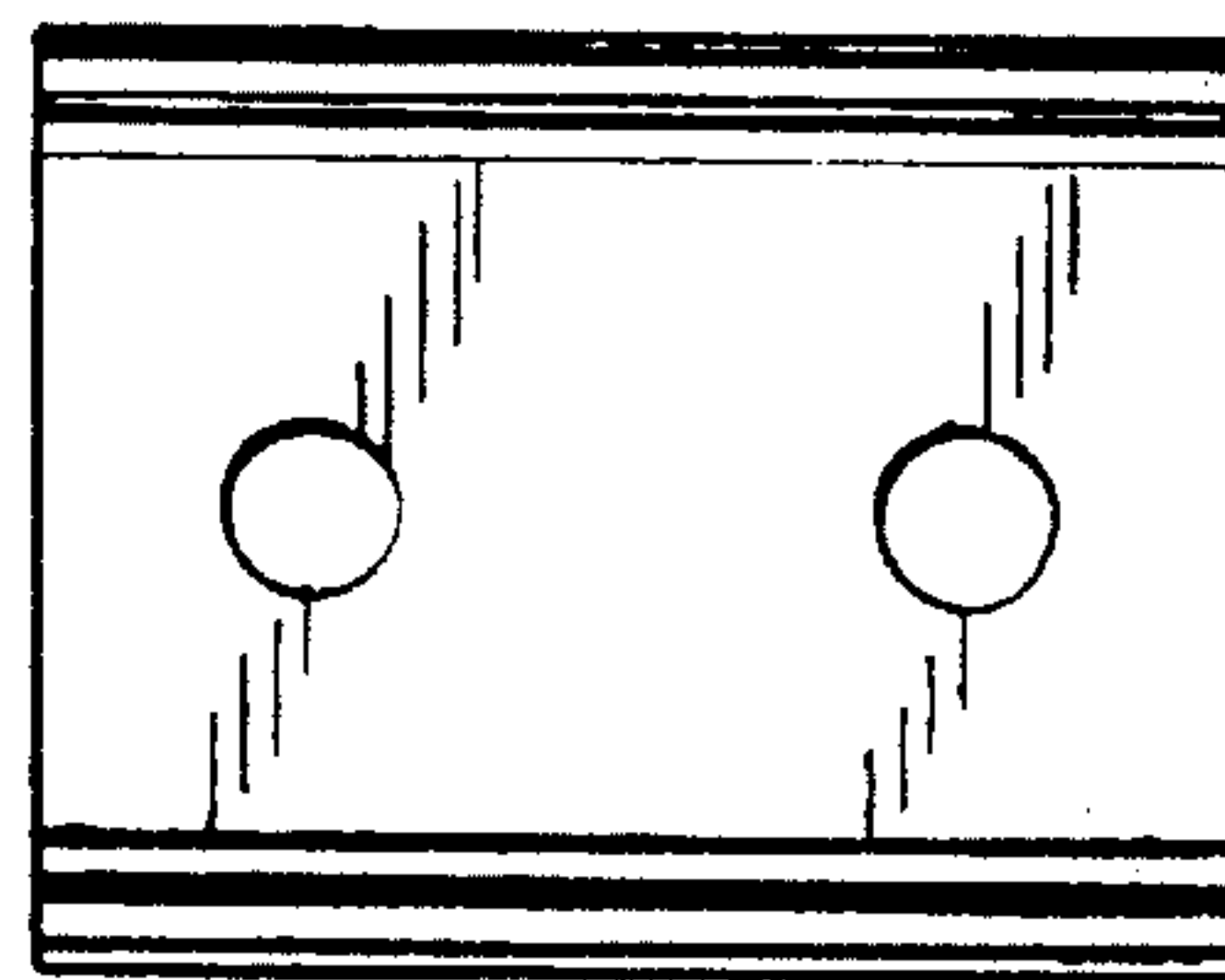

FIG. 9

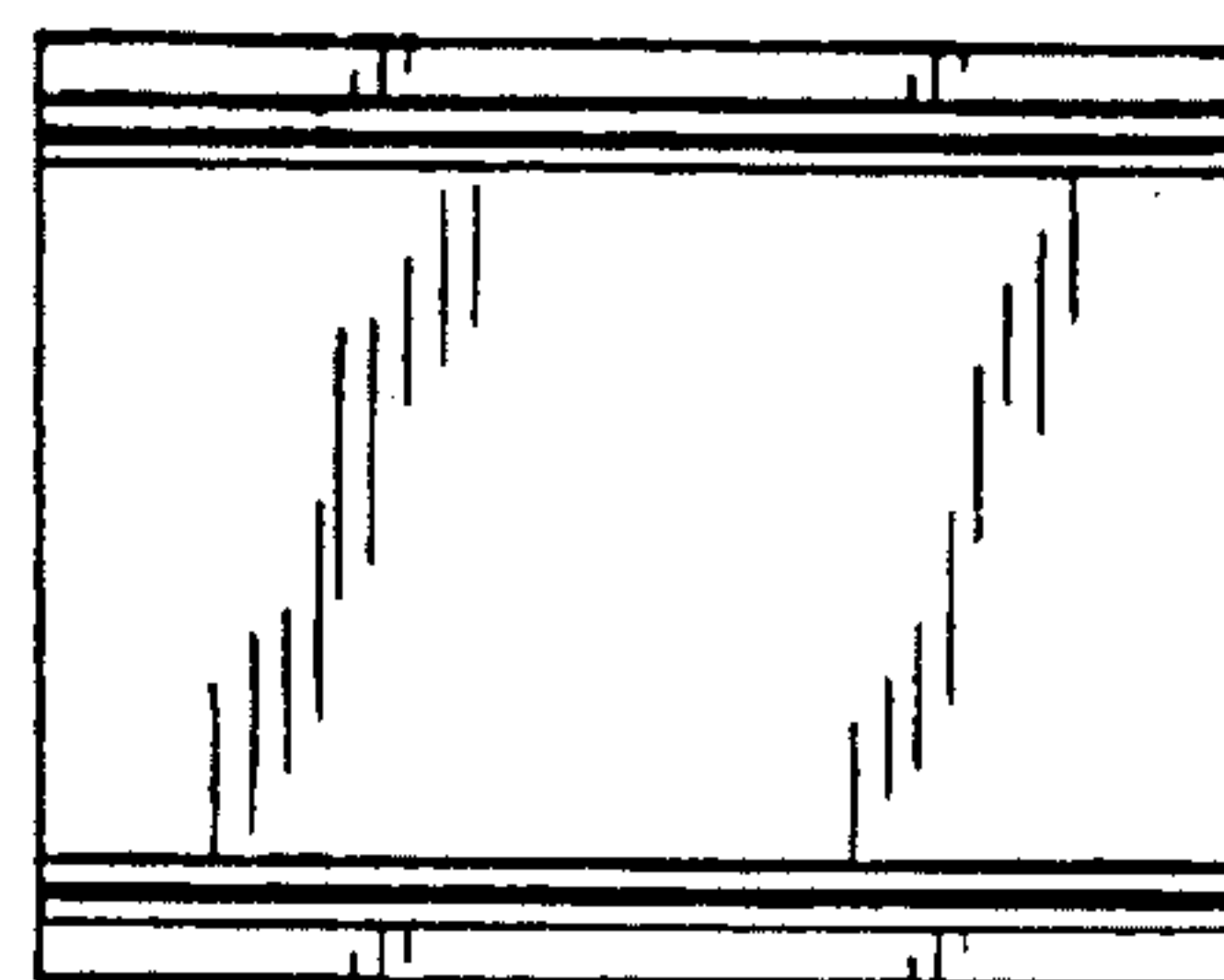

FIG. 10

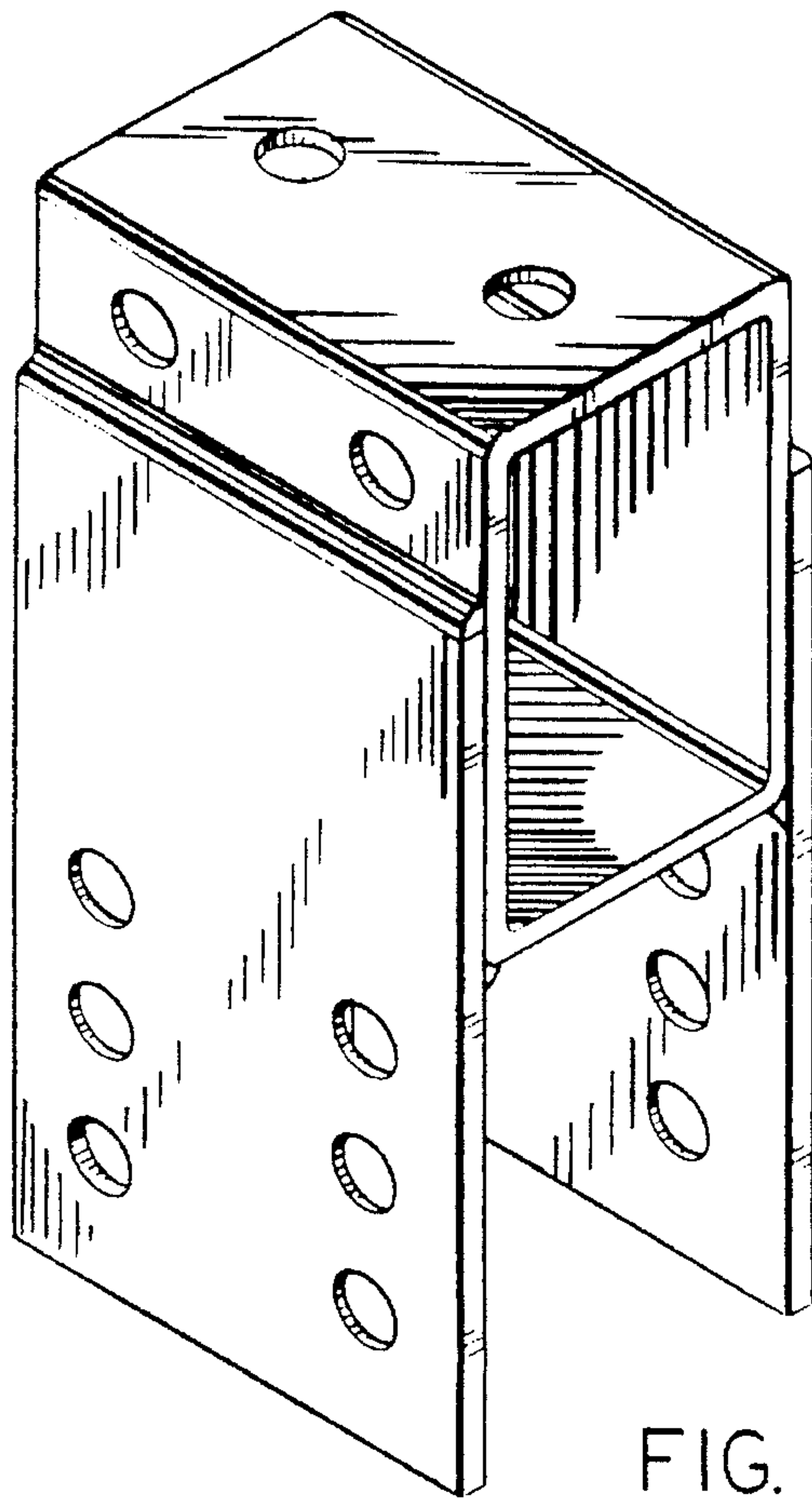

FIG. 11

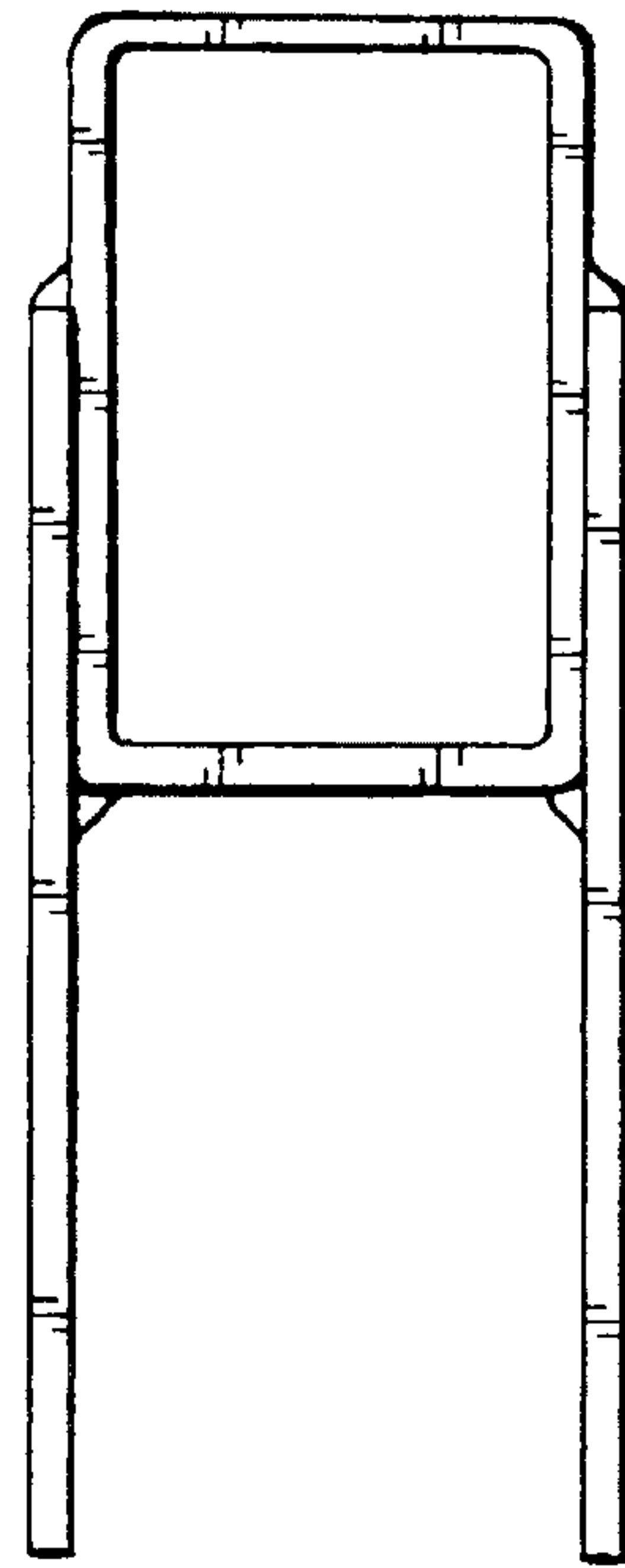

FIG. 12

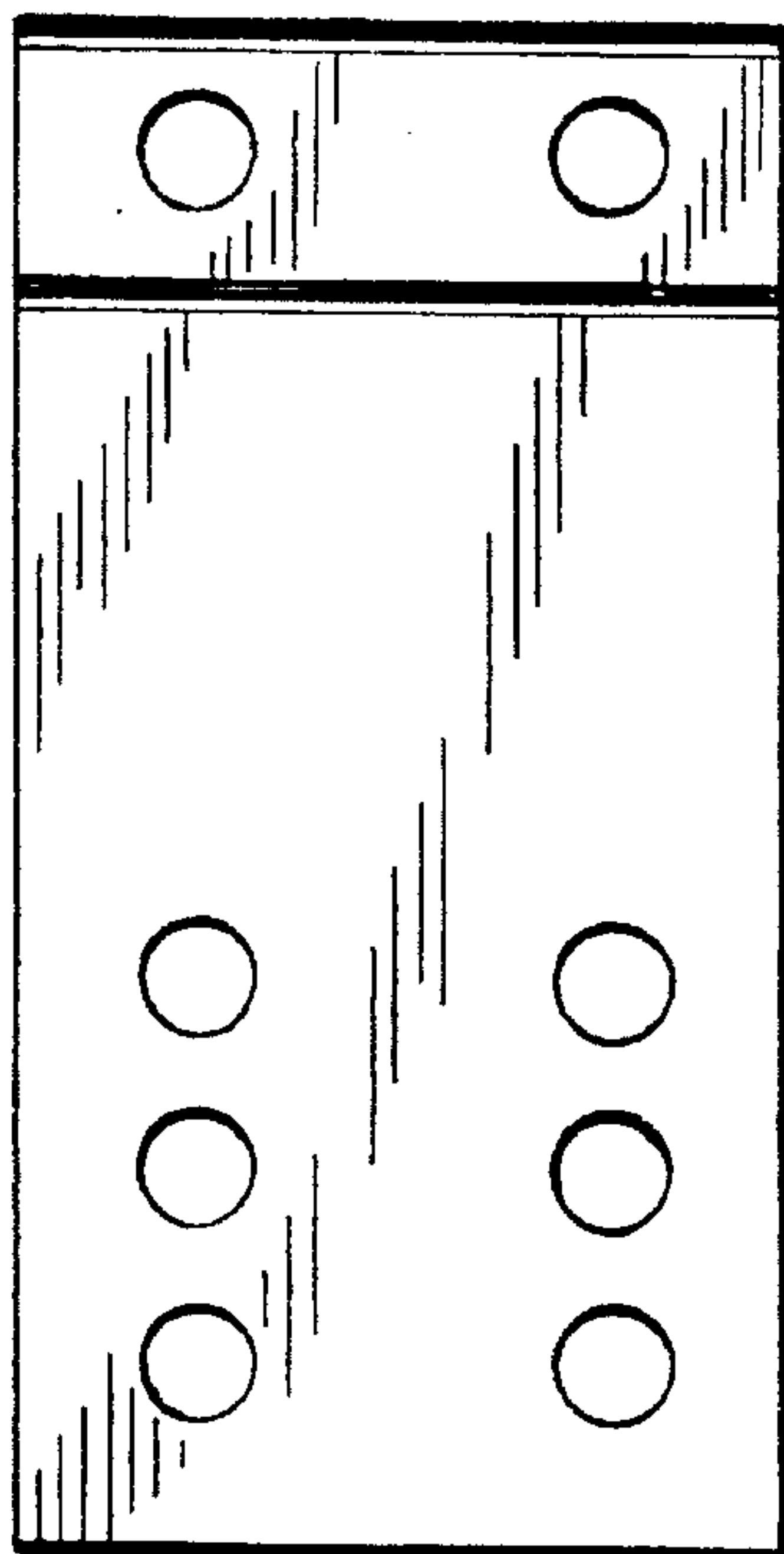

FIG. 13

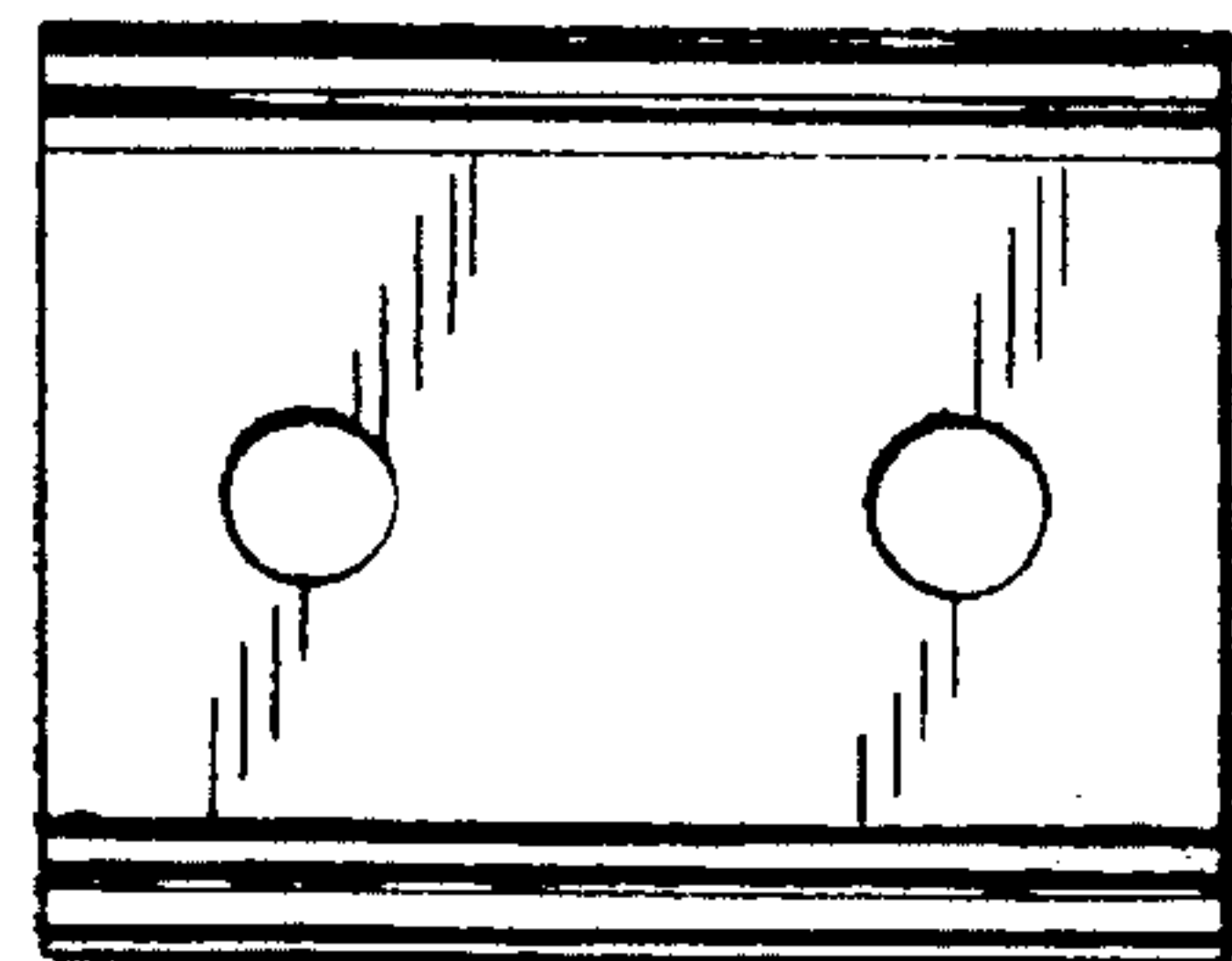

FIG. 14

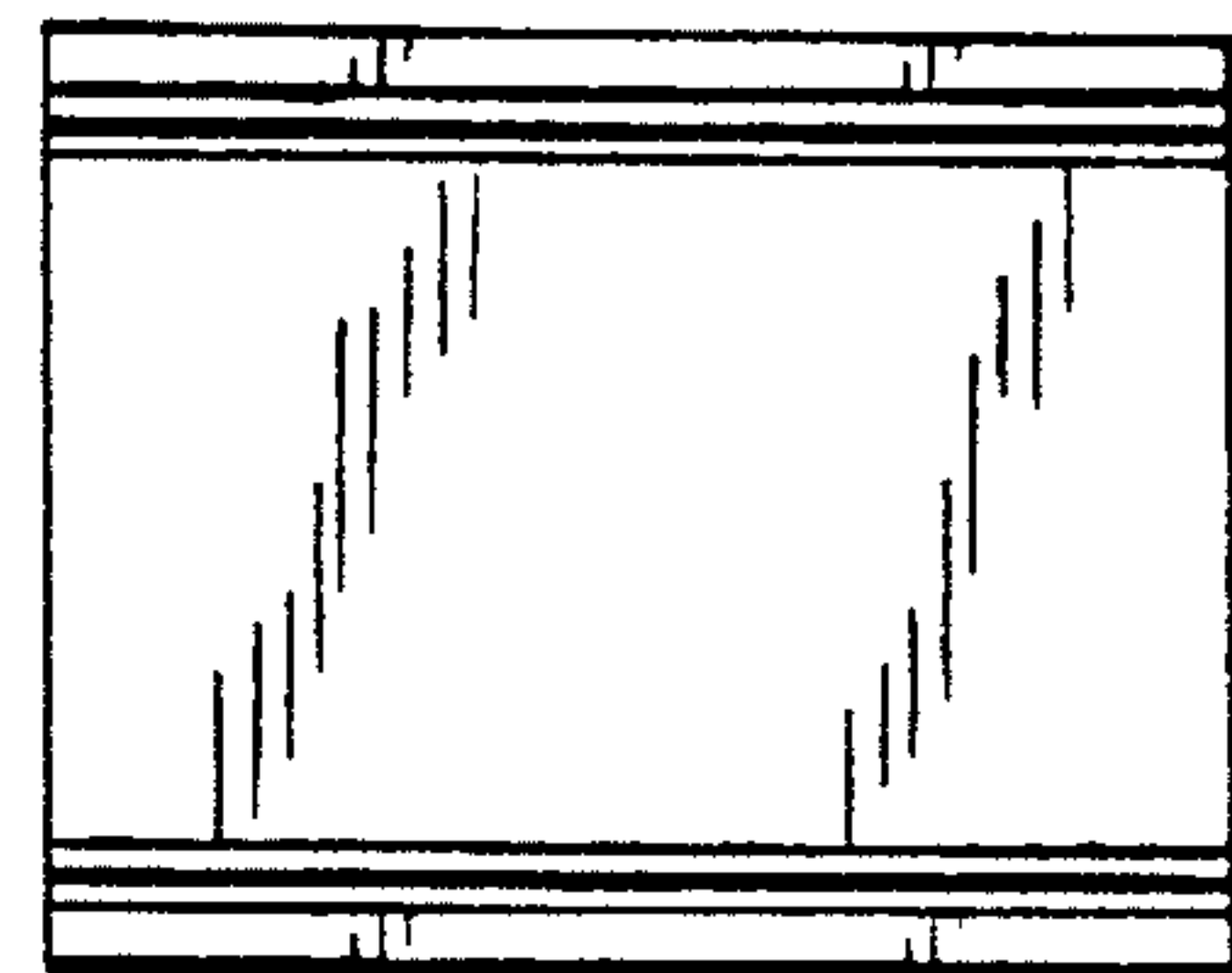

FIG. 15