



US00D370057S

# United States Patent [19]

Muderlak

[11] Patent Number: **Des. 370,057**

[45] Date of Patent: **\*\*May 21, 1996**

[54] **AUTOMATIC FLUSH MECHANISM HOUSING**

[75] Inventor: **Kenneth J. Muderlak**, Shorewood, Wis.

[73] Assignee: **Technical Concepts, L.P.**, Elk Grove Village, Ill.

[\*\*] Term: **14 Years**

[21] Appl. No.: **37,924**

[22] Filed: **Apr. 24, 1995**

[52] U.S. Cl. .... **D23/309**

[58] **Field of Search** ..... D23/233-237, D23/244-249, 295, 301, 303, 309; 4/249, 305, 313, 406, DIG. 3; 251/40, 129.03; 137/624.12, 624.18

[56] **References Cited**

**U.S. PATENT DOCUMENTS**

- 2,552,625 5/1951 Filliung .
- 2,635,691 4/1953 Filliung .
- 3,056,143 10/1962 Foster .

- 3,193,846 7/1965 Lefebvre ..... 4/305
- 3,416,162 12/1968 Homblen ..... 4/305
- 4,918,762 4/1990 Uhlmann ..... 4/305 X
- 5,313,623 5/1994 Saadi et al. .... 4/305

*Primary Examiner*—Stella Reid  
*Assistant Examiner*—E. Watterson  
*Attorney, Agent, or Firm*—Welsh & Katz, Ltd.

[57] **CLAIM**

The ornamental design for an automatic flush mechanism housing, as shown and described.

**DESCRIPTION**

FIG. 1 is a front, right side and bottom perspective view of an automatic flush mechanism housing showing my new design;  
FIG. 2 is a front elevation view thereof;  
FIG. 3 is a rear elevation view thereof;  
FIG. 4 is a right side elevation view thereof;  
FIG. 5 is a left side elevation view thereof;  
FIG. 6 is a top plan view thereof; and,  
FIG. 7 is a bottom plan view thereof.

**1 Claim, 2 Drawing Sheets**

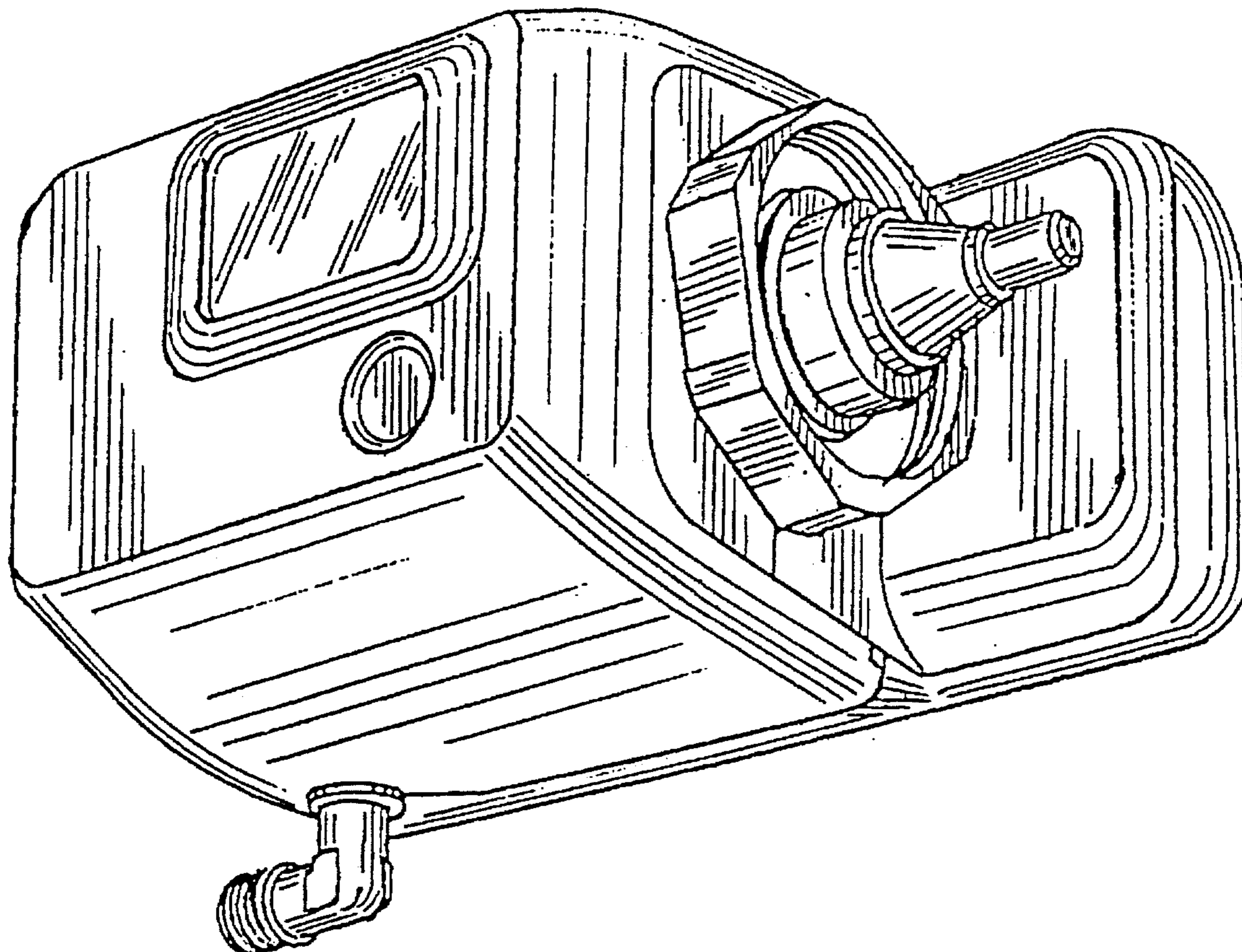

FIG.1

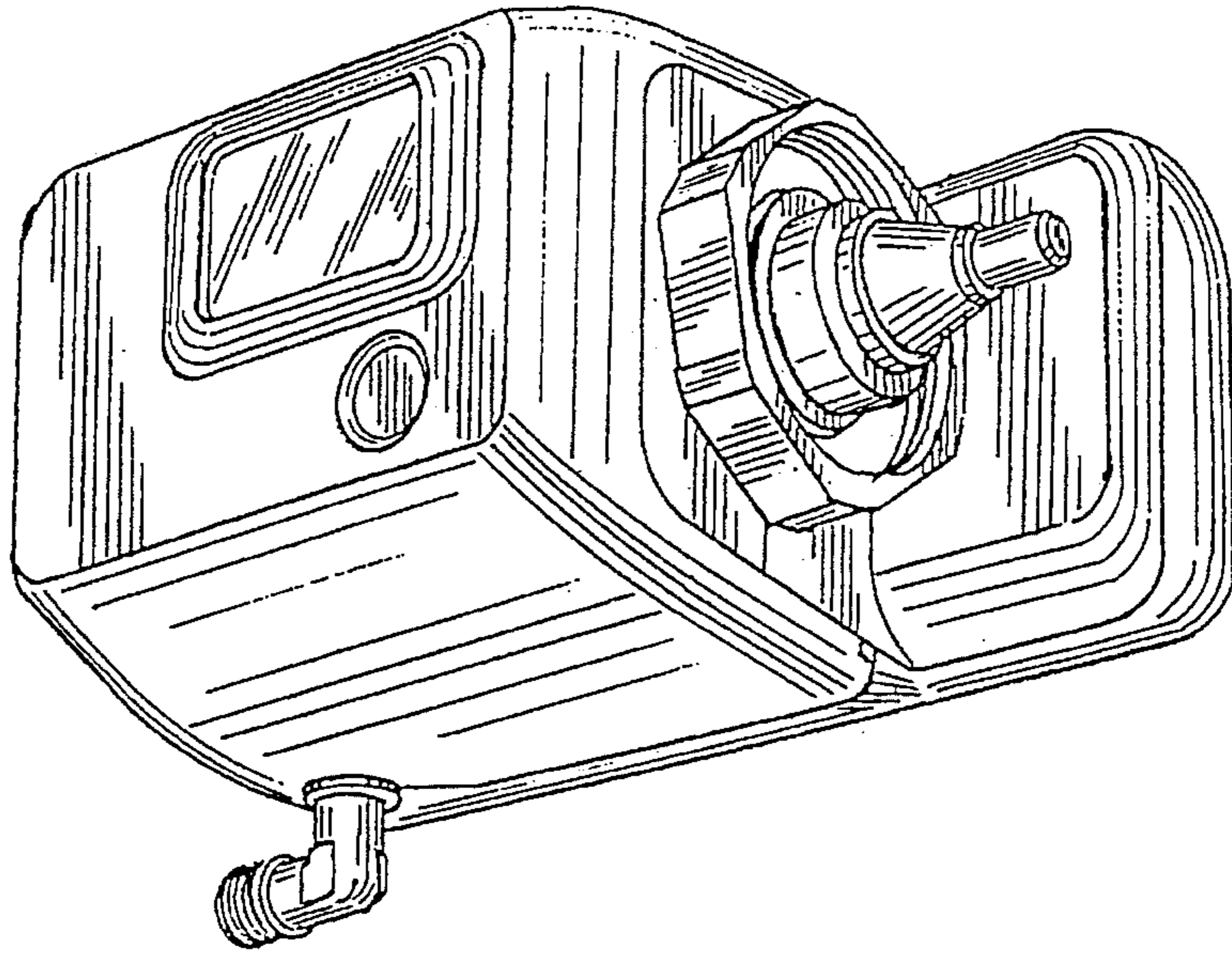

FIG.2

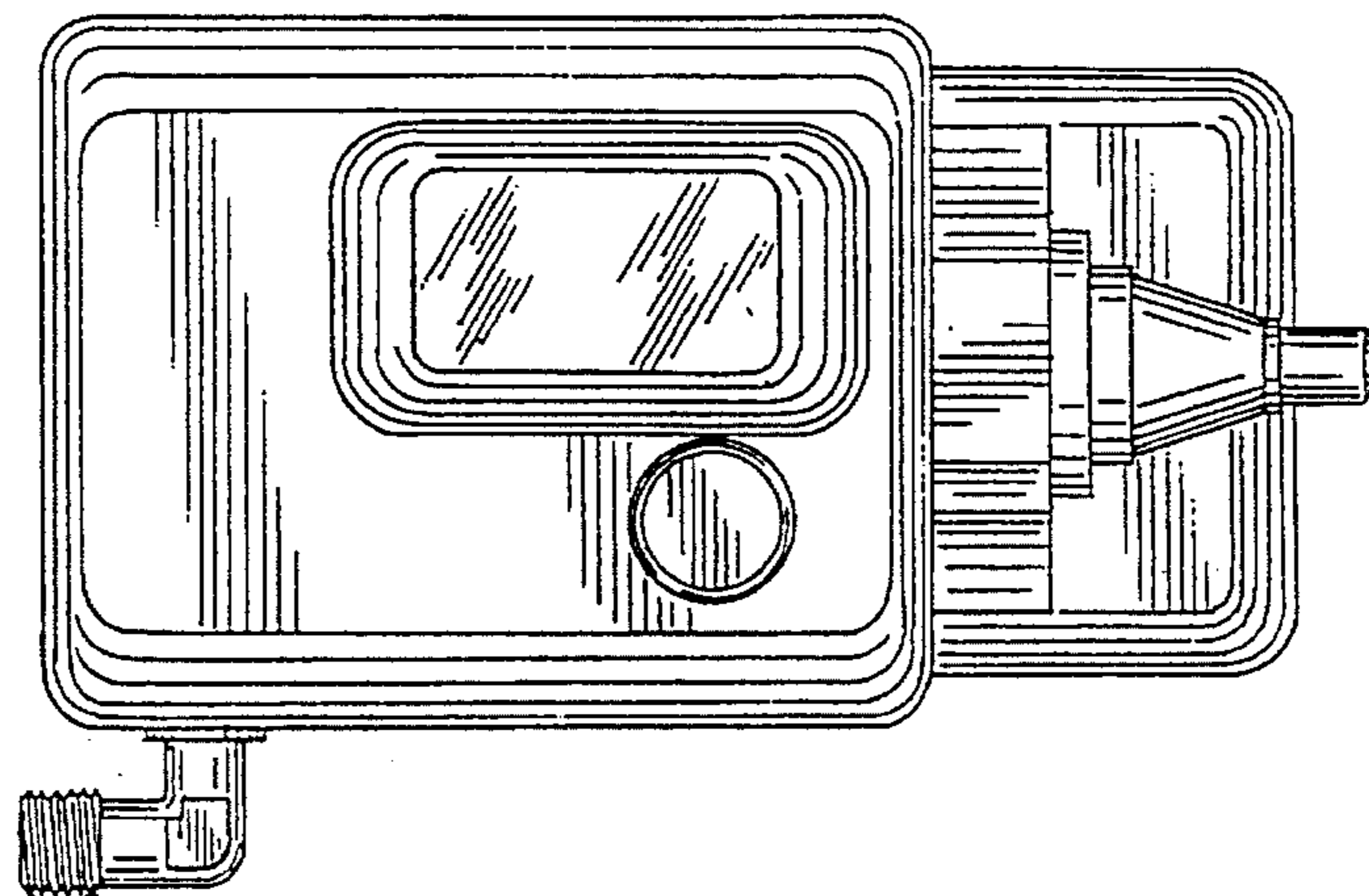

FIG.3

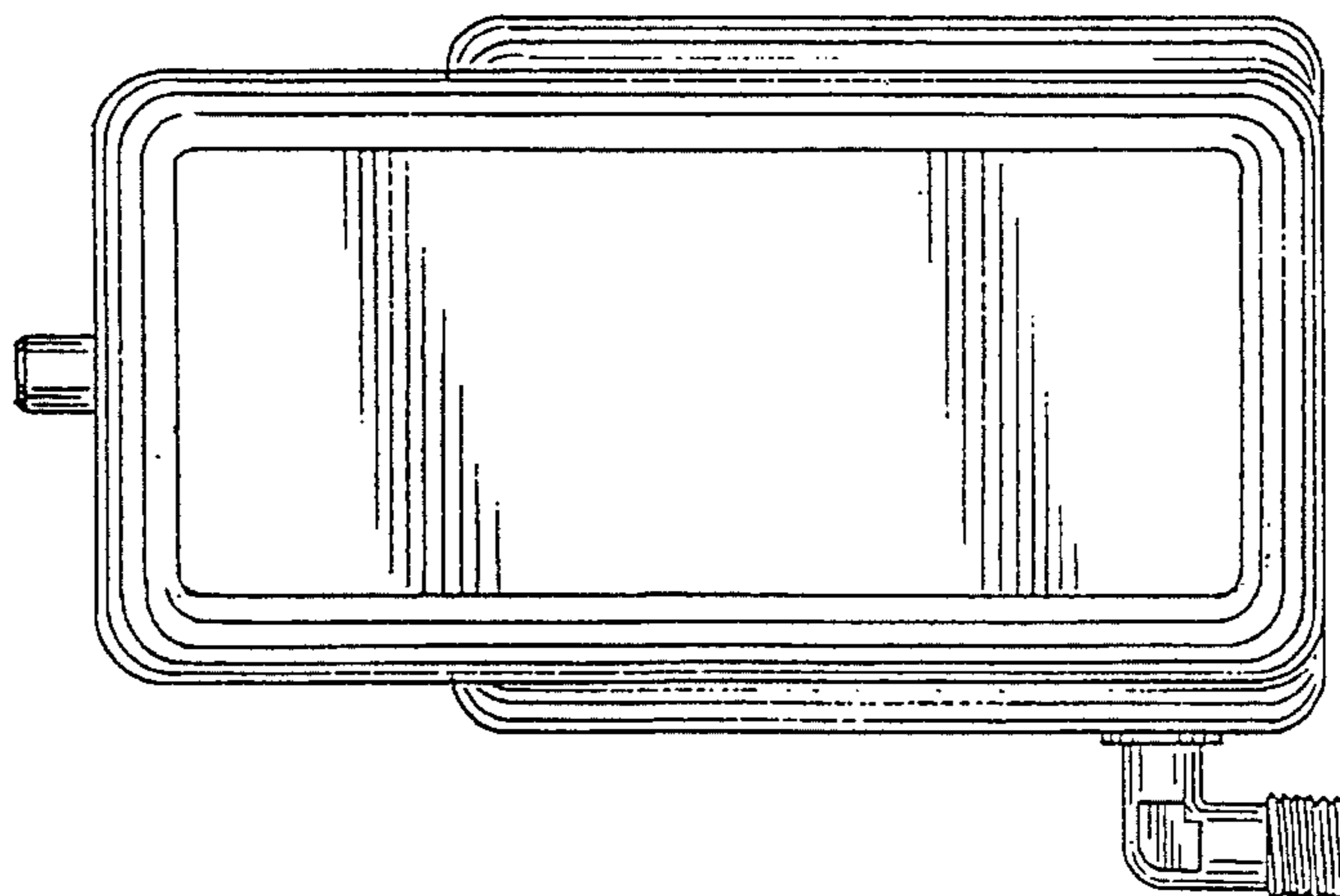

FIG. 4

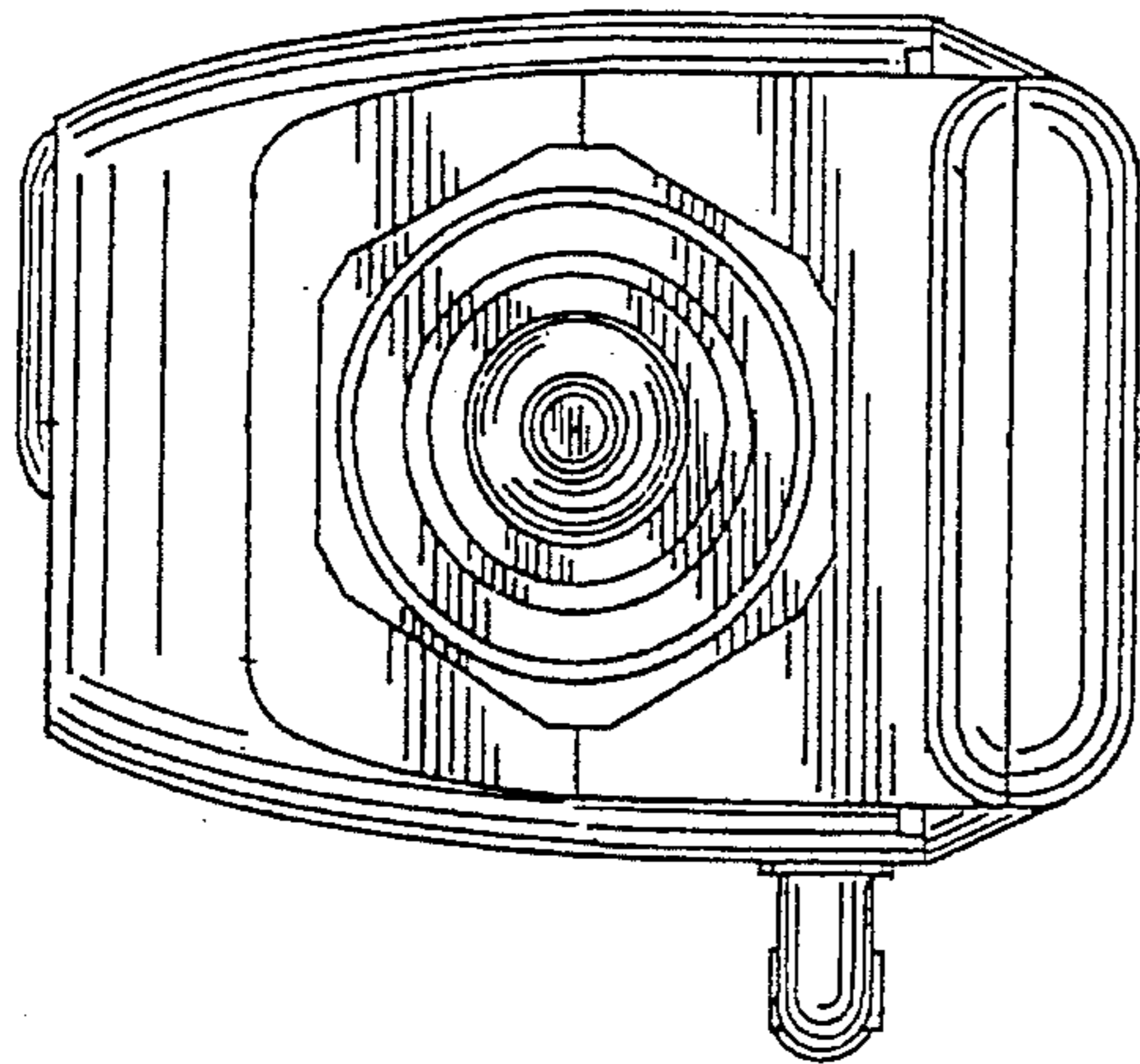

FIG. 5

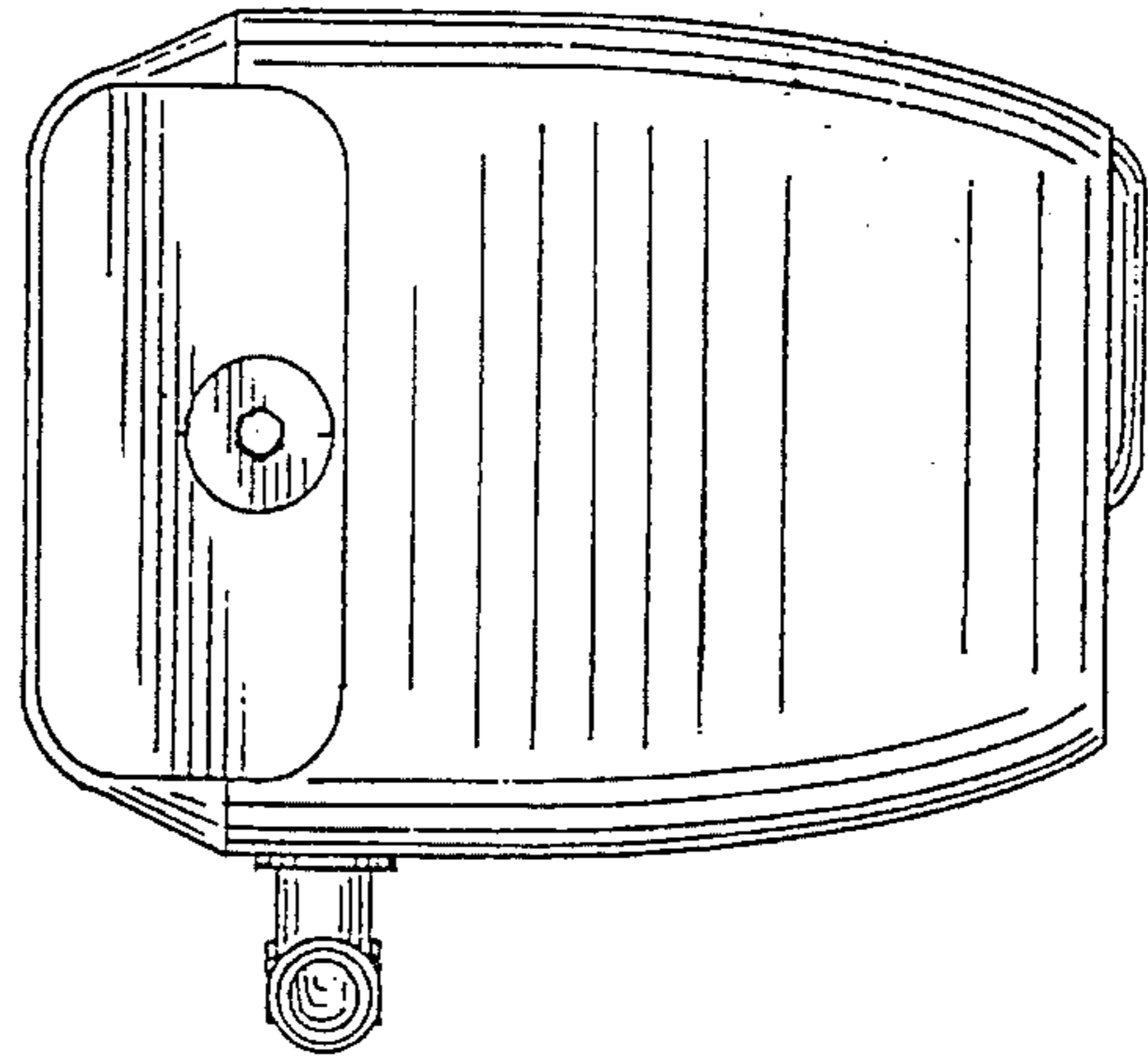

FIG. 6

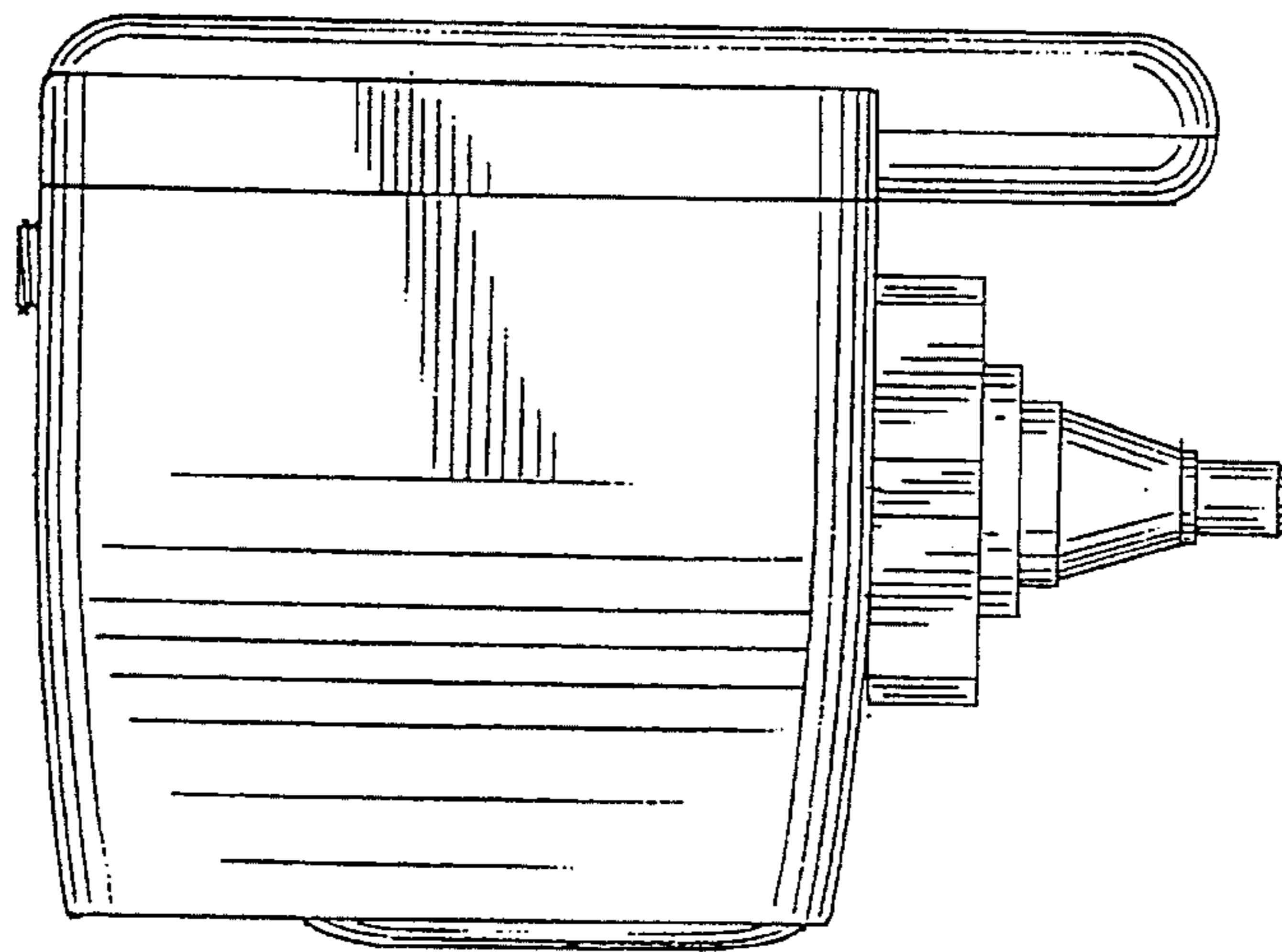

FIG. 7

