



US00D369991S

United States Patent [19]

[11] Patent Number: **Des. 369,991**

Hunter et al.

[45] Date of Patent: ****May 21, 1996**

[54] TRUCK

D. 316,987 5/1991 Machida et al. D12/98
D. 336,266 6/1993 Hunter D12/98

[75] Inventors: **Kevin Hunter**, Laguna Niguel, Calif.;
Masayoshi Haga, Nagoya, Japan;
Akira Yamaguchi, Hino, Japan; **Hideo Karikomi**, Tokyo, Japan; **Tetsuro Hakamada**, Hachioji, Japan; **Yusuke Fukushima**, Hino, Japan

OTHER PUBLICATIONS

1992 Isuzu Catalog, pp. 5 & 6, regular cab S 4WD Pickup truck & space cab LS 4WD Pickup Truck.
Car & Driver, Dec. 1992, p. 115, Mitsubishi pick up truck, lower rt side of page.
Car & Driver, Dec. 1992, p. 116, Toyota T100 SR5 pickup truck, top of page.
Car & Driver, Dec. 1992, p. 129, Ford Ranger XLT.

[73] Assignee: **Toyota Jidosha Kabushiki Kaisha**, Japan

Primary Examiner—M. H. Tung
Attorney, Agent, or Firm—Fred Flam; Flam&Flam

[**] Term: **14 Years**

[21] Appl. No.: **29,573**

[57] CLAIM

[22] Filed: **Oct. 11, 1994**

The ornamental design for a truck, as shown and described.

Related U.S. Application Data

DESCRIPTION

[63] Continuation-in-part of Ser. No. 14,693, Oct. 28, 1993, Pat. No. Des. 357,213.

[52] U.S. Cl. **D12/98**

[58] Field of Search D12/82-100; 296/185-6

FIG. 1 is a left, front perspective view of a truck showing our new design;
FIG. 2 is a left, rear perspective view thereof;
FIG. 3 is a front elevational view;
FIG. 4 is a rear elevational view;
FIG. 5 is a left side elevational view thereof, the right side is a mirror image except for the gas tank cover; and,
FIG. 6 is a top plan view thereof.

[56] References Cited

U.S. PATENT DOCUMENTS

D. 311,160 10/1990 Hackett et al. D12/98
D. 313,379 1/1991 Machida et al. D12/98

1 Claim, 4 Drawing Sheets

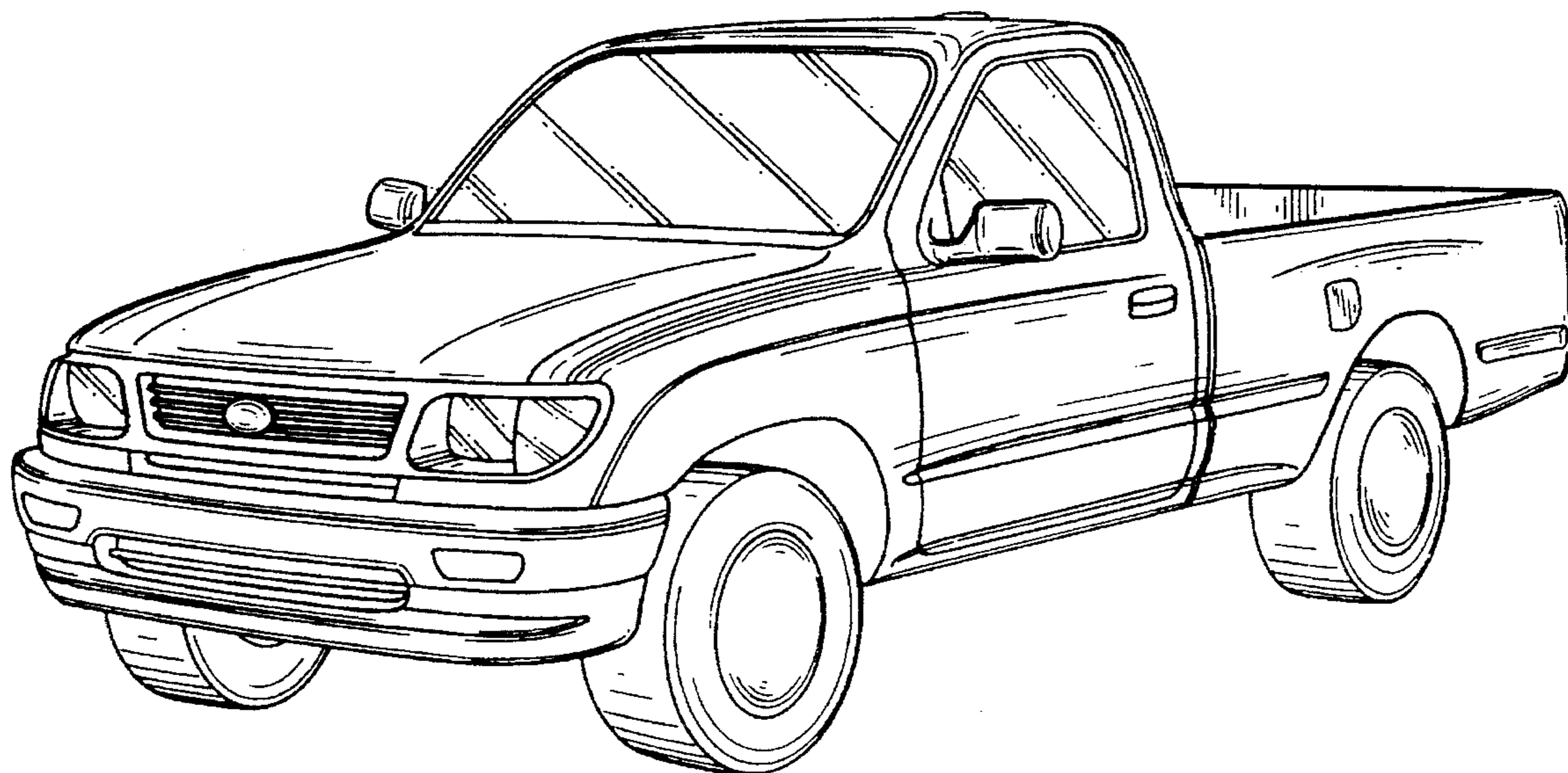

FIG. 1

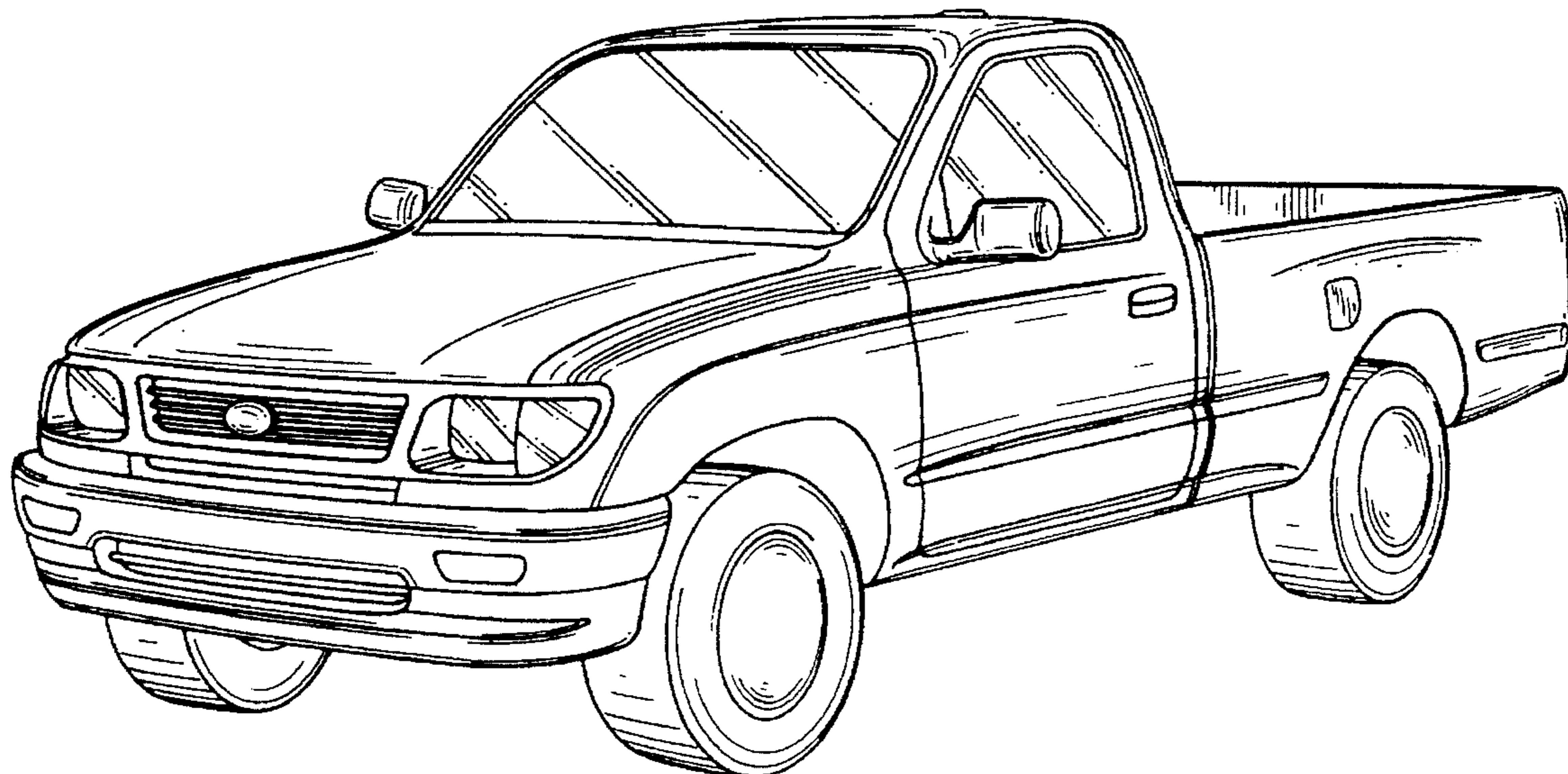

FIG. 2

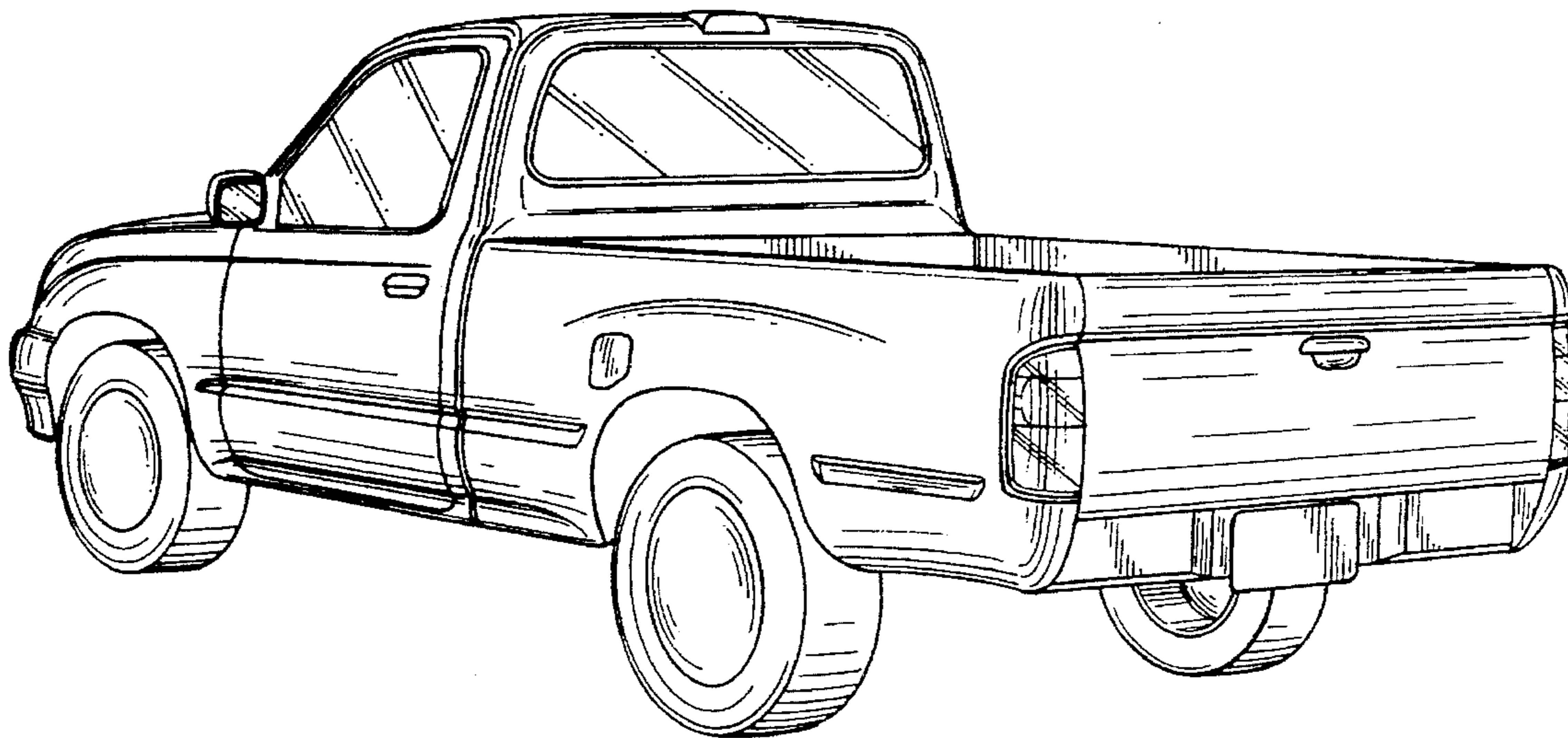

FIG. 3

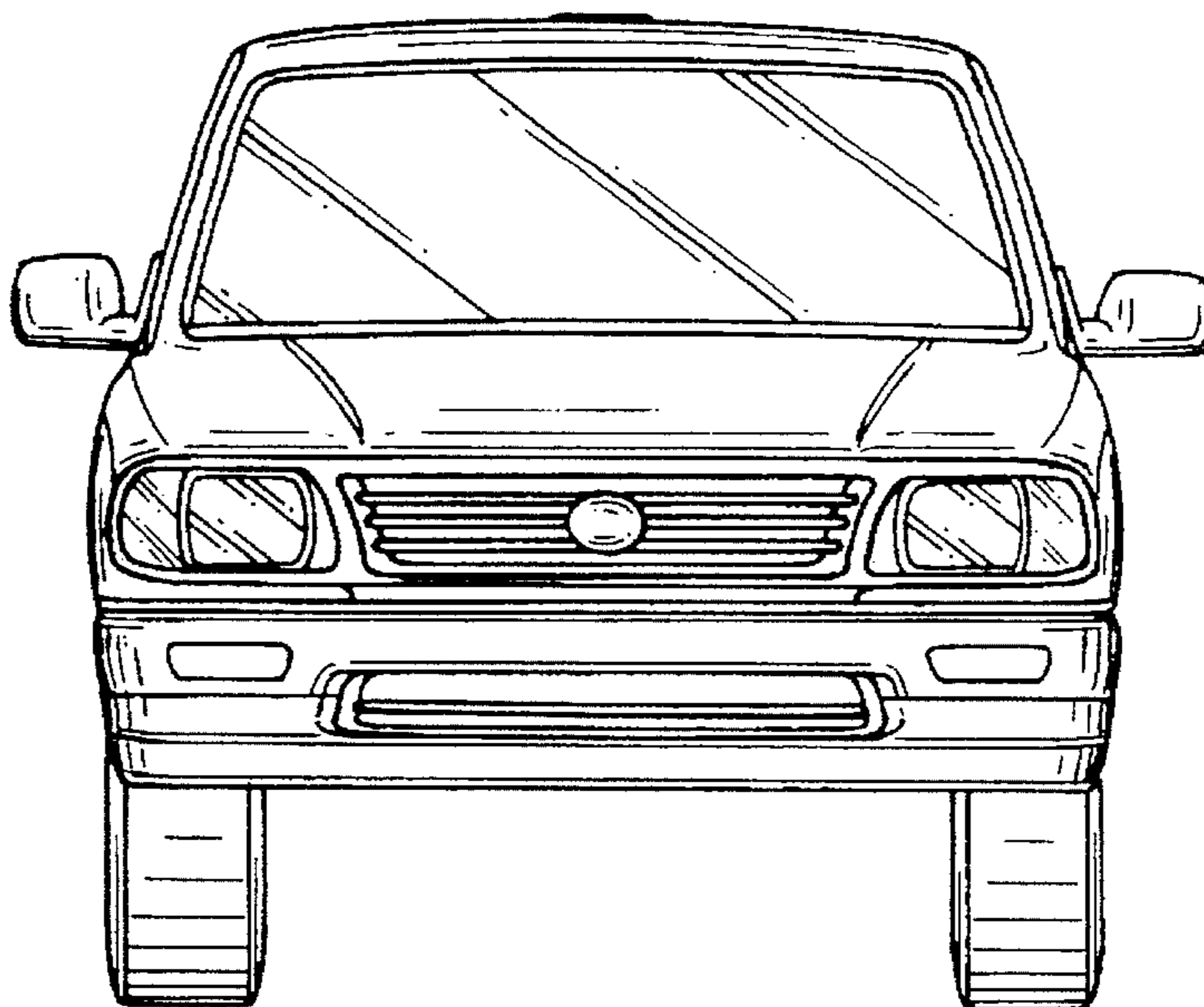

FIG. 4

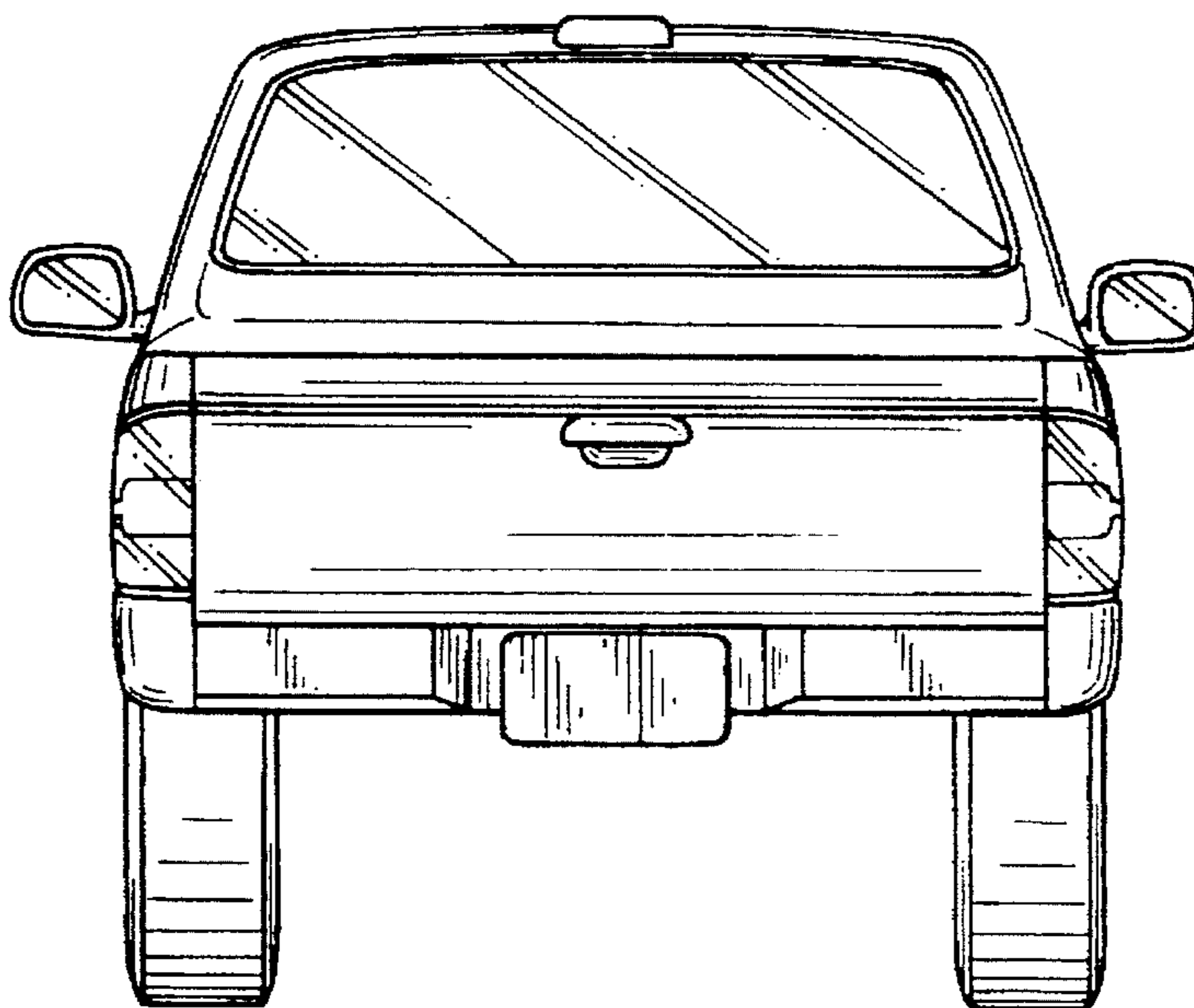

FIG. 5

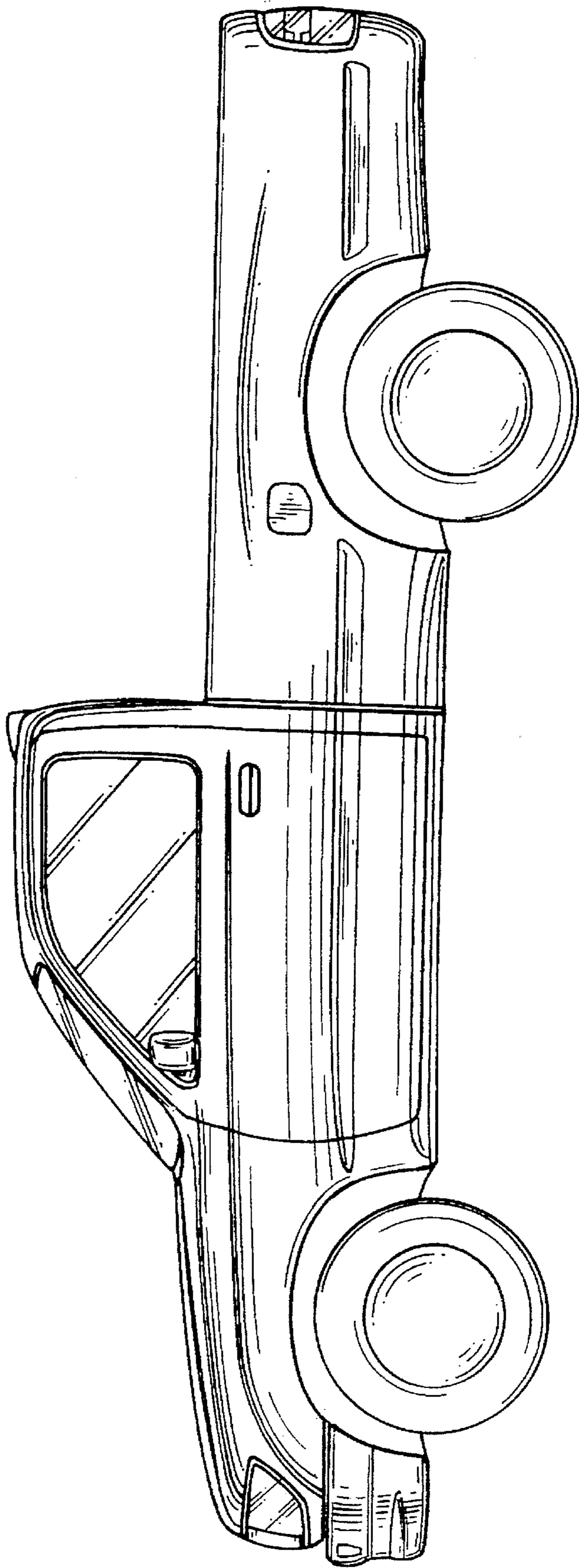

FIG. 6

