



US00D369835S

# United States Patent [19]

[11] Patent Number: **Des. 369,835**

Couch et al.

[45] Date of Patent: **\*\*May 14, 1996**

[54] CONTROL STICK AND BASE

[75] Inventors: **Johnny D. Couch**, San Jose; **Sarah M. Richmond**, Foster City; **Ira L. Velinsky**, Saratoga, all of Calif.; **Stephen K. Guerrera**, Milford, Mass.; **Gregory H. Hunter**, Westwood, Mass.; **John D. Gundlach**, Rowley, Mass.

4,688,443 8/1987 Fabre et al. .... 273/DIG. 28 X  
 5,114,157 5/1992 Kita ..... 273/148 B X  
 5,375,831 12/1994 Hsien-Chung ..... 273/148 B

### OTHER PUBLICATIONS

Merchandise, Mar.-1983, p. 53.  
 Vending Times, Jul.-1982, p. 40.  
 Hong Kong Electronics, 1985, p. 175.

[73] Assignee: **Sega Enterprises, Ltd.**, Japan

[\*\*] Term: **14 Years**

*Primary Examiner*—Prabhakar G. Deshmukh  
*Attorney, Agent, or Firm*—Skjerven, Morrill, MacPherson,  
 Franklin & Friel; David W. Heid

[21] Appl. No.: **36,220**

[22] Filed: **Mar. 15, 1995**

[52] U.S. Cl. .... **D21/48**

[58] Field of Search ..... D21/1, 13, 48;  
 273/148 B, 433-438, DIG. 28; D14/125,  
 126, 218

[57] **CLAIM**

The ornamental design for a control stick and base, as shown and described.

### DESCRIPTION

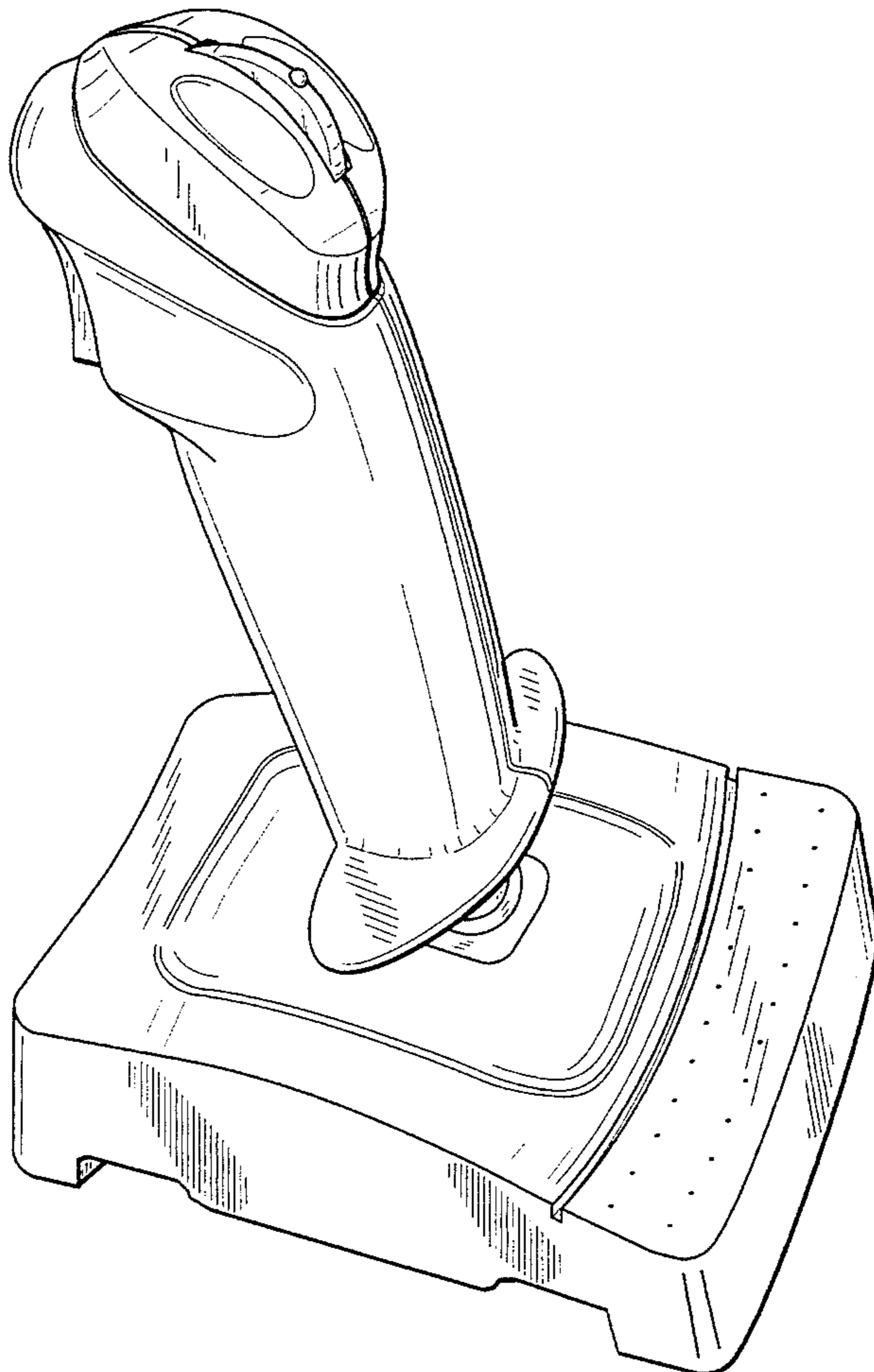
FIG. 1 is a perspective front elevation view of a control stick and base;  
 FIG. 2 is a top plan view thereof;  
 FIG. 3 is a bottom plan view thereof;  
 FIG. 4 is a front elevation view thereof;  
 FIG. 5 is a rear elevation view thereof;  
 FIG. 6 is a right side elevational view thereof; and,  
 FIG. 7 is a left side elevational view thereof.

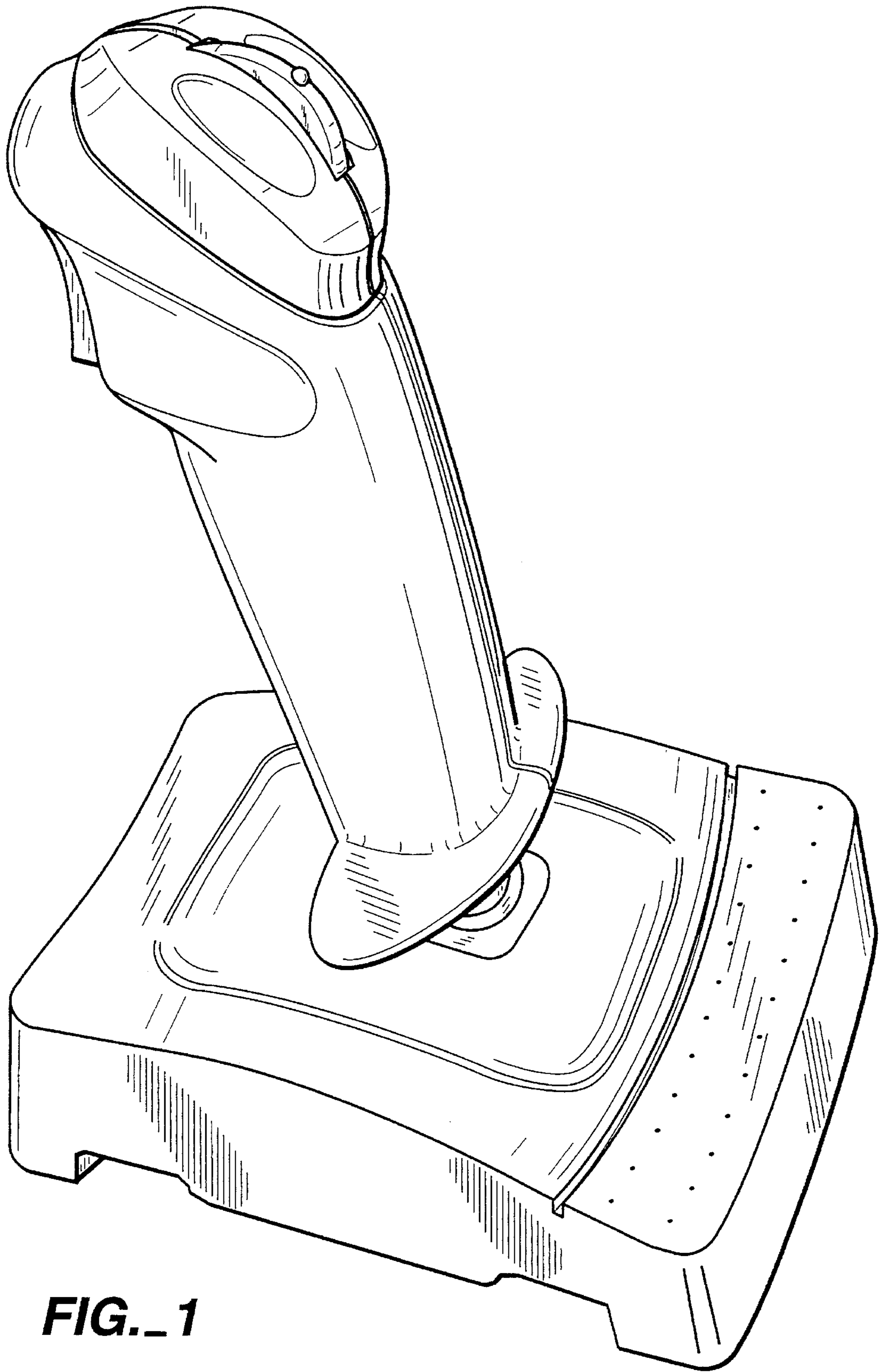
[56] **References Cited**

U.S. PATENT DOCUMENTS

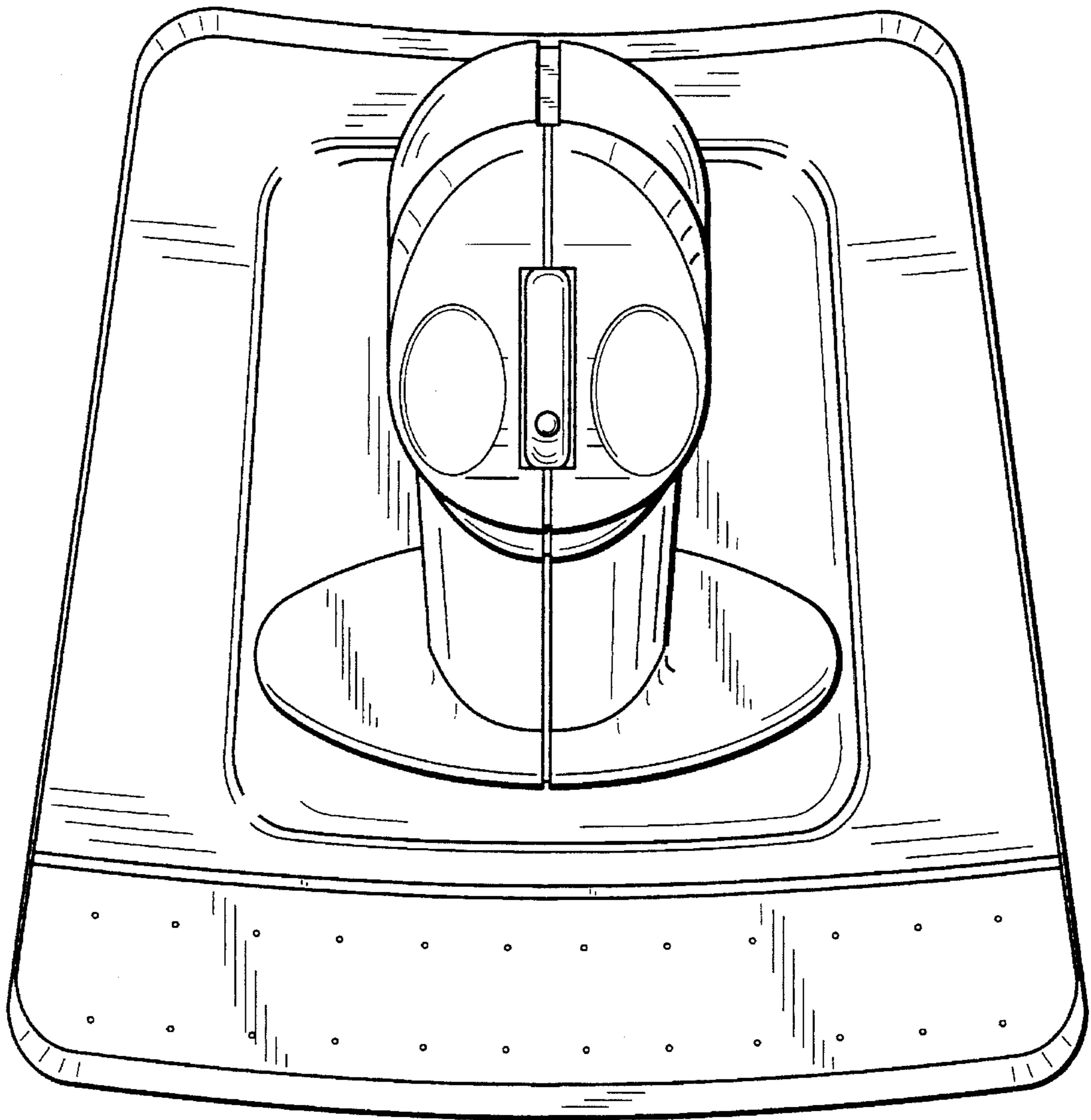
D. 317,153	5/1991	Mackenzie	.....	D21/48	X
D. 345,994	4/1994	Shian	.....	D21/48	
D. 351,625	10/1994	Carter et al.	.....	D21/48	
D. 352,331	11/1994	Wu	.....	D21/48	
4,509,383	4/1985	Yeh	.....	273/438	X

**1 Claim, 7 Drawing Sheets**

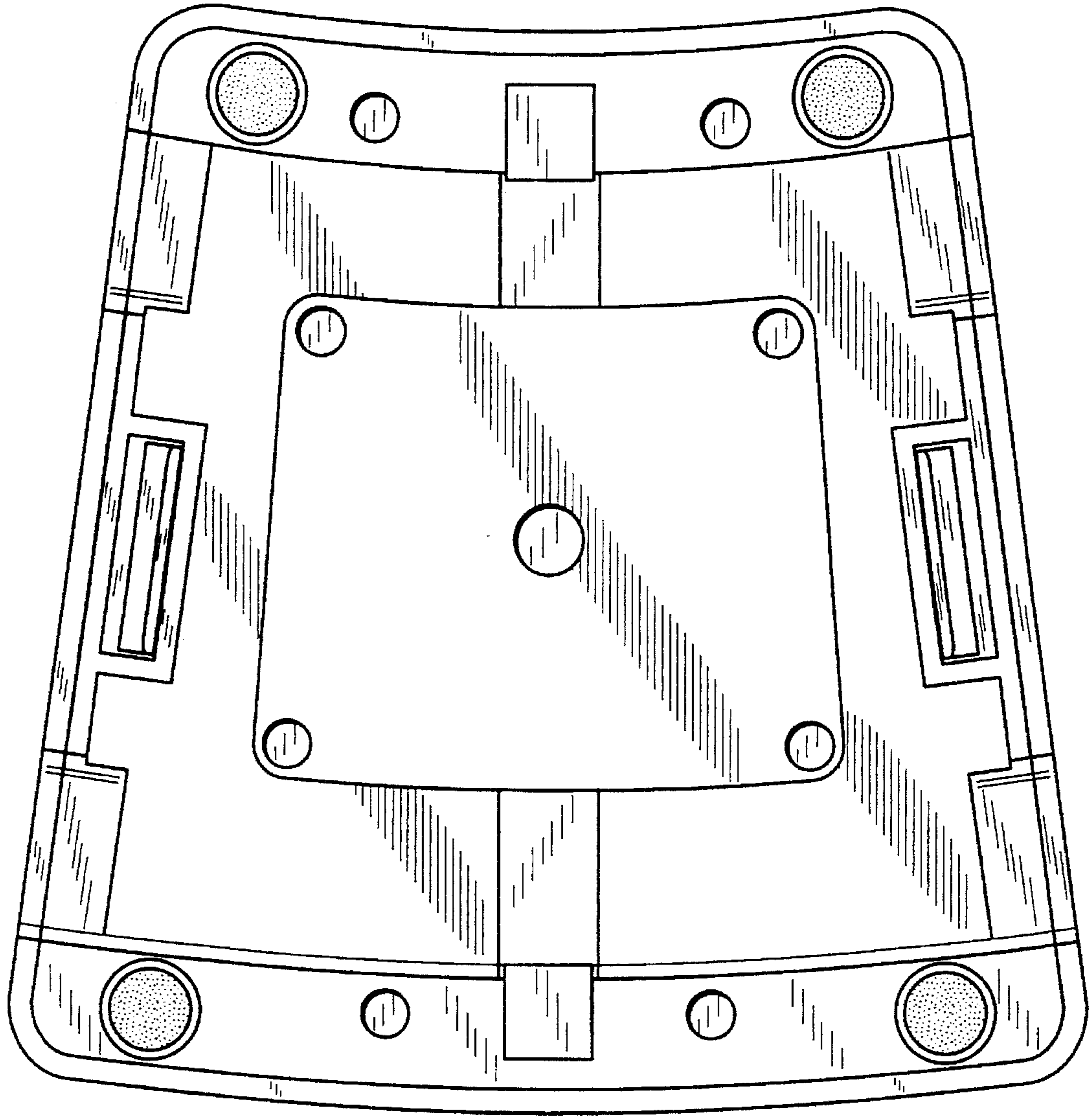




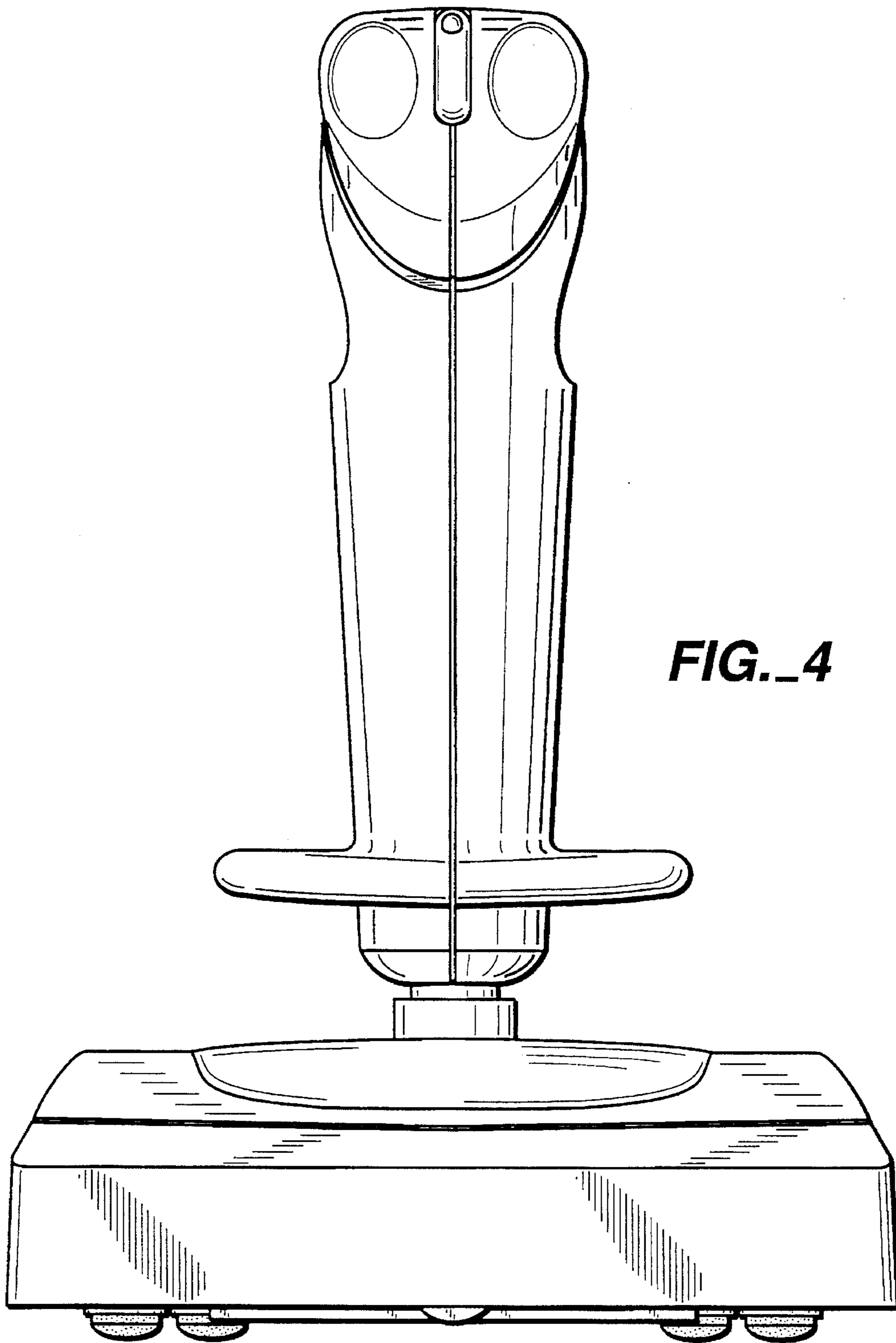
**FIG. 1**



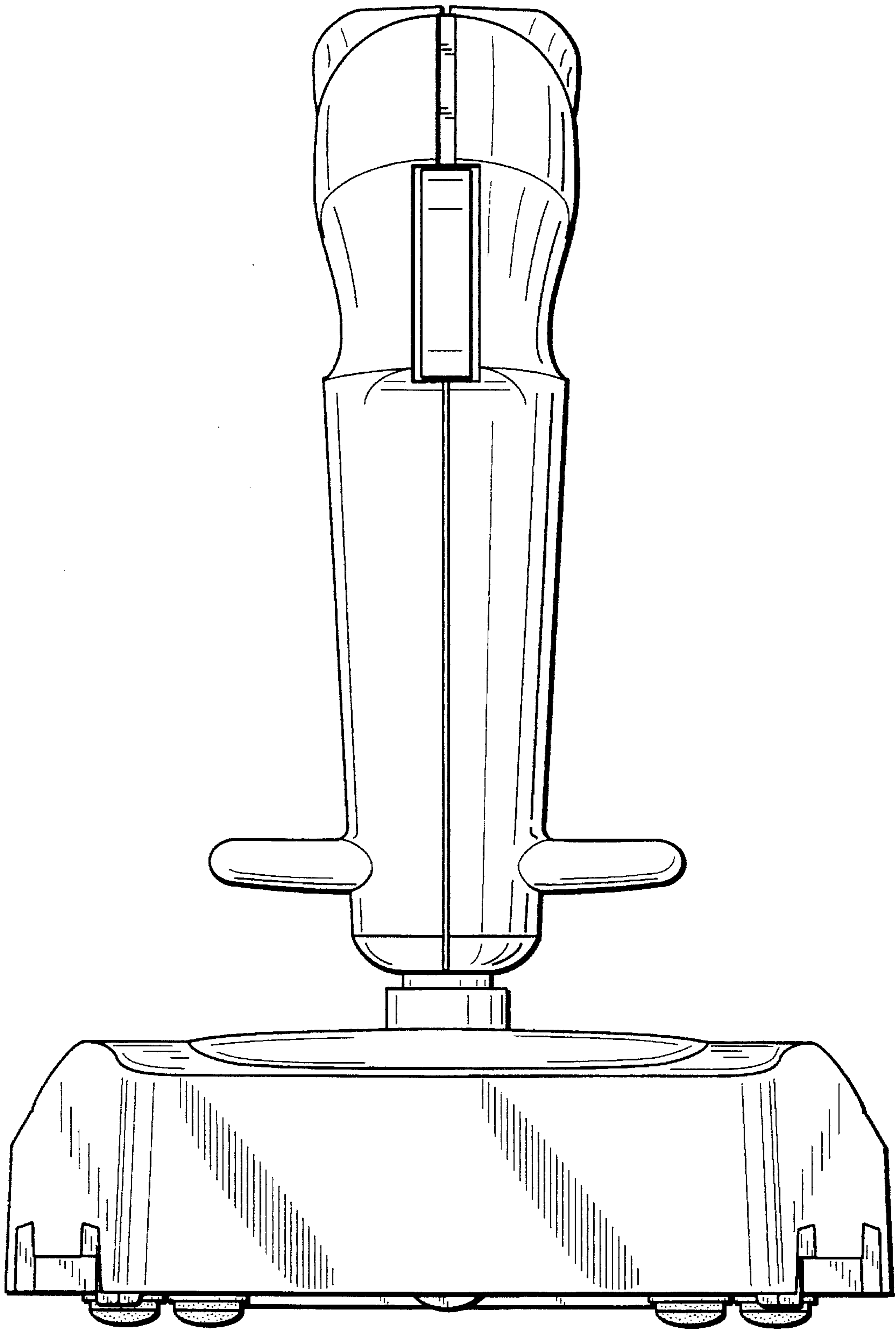
**FIG. 2**



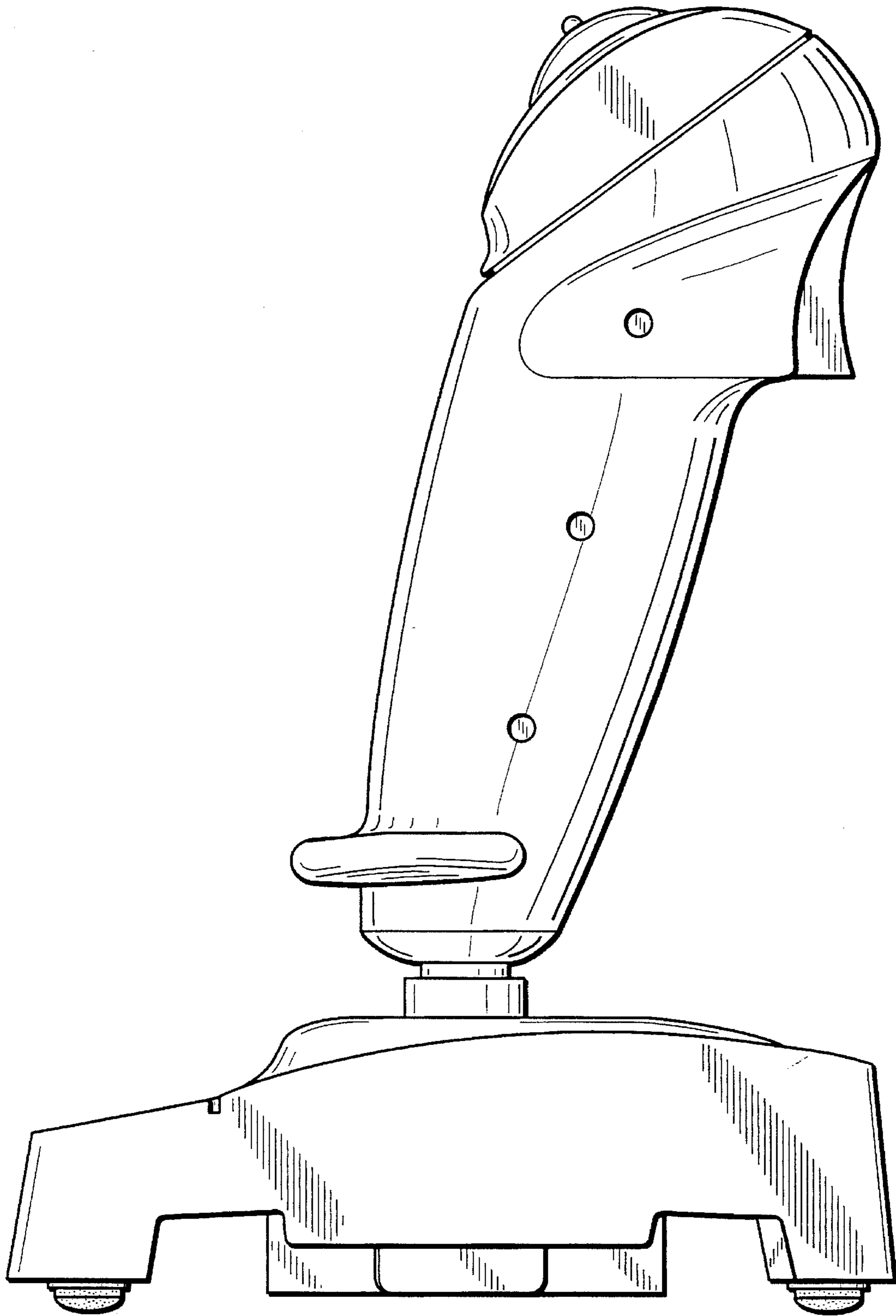
**FIG. 3**



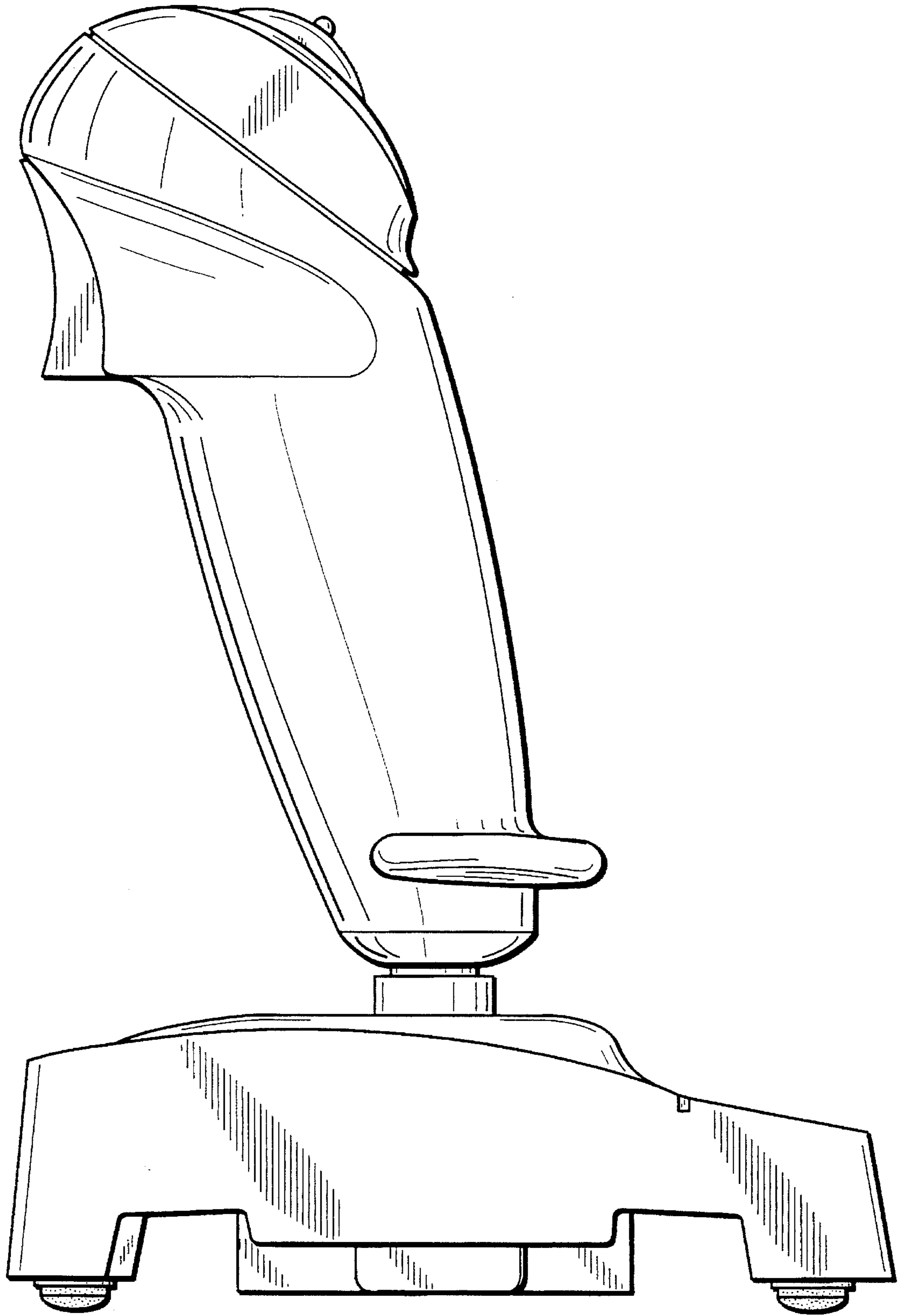
**FIG. 4**



**FIG. 5**



**FIG. 6**



**FIG. 7**