



US00D369806S

# United States Patent [19] Ichikawa

[11] Patent Number: **Des. 369,806**

[45] Date of Patent: **\*\*May 14, 1996**

[54] **COMBINED AMPLIFIER AND SPEAKERS**

5,319,164 6/1994 Shen ..... D14/215 X

[75] Inventor: **Kazuo Ichikawa**, Tokyo, Japan

*Primary Examiner*—Ted Shooman

*Assistant Examiner*—Nanda Bondade

[73] Assignee: **Sony Corporation**, Japan

*Attorney, Agent, or Firm*—Beveridge, DeGrandi, Weilacher & Young

[\*\*] Term: **14 Years**

[57] **CLAIM**

[21] Appl. No.: **23,689**

The ornamental design for a combined amplifier and speakers, as shown and described.

[22] Filed: **May 31, 1994**

**DESCRIPTION**

[30] **Foreign Application Priority Data**

Dec. 3, 1993 [JP] Japan ..... 5-36504

[52] U.S. Cl. .... **D14/172; D14/216**

[58] **Field of Search** ..... D14/124, 126,  
D14/155, 168, 169, 171-172, 188-198,  
204, 209, 213, 215-216, 219, 221-222,  
265, 299; 181/153; 455/344, 347, 350-351

FIG. 1 is a perspective view of the combined amplifier and speakers showing my new design;

FIG. 2 is a front view of the combined amplifier and speakers;

FIG. 3 is a top plan view of the combined amplifier and speakers;

FIG. 4 is a left side view of the combined amplifier and speakers;

FIG. 5 is a right side view of the combined amplifier and speakers;

FIG. 6 is a bottom plan view of the combined amplifier and speakers; and,

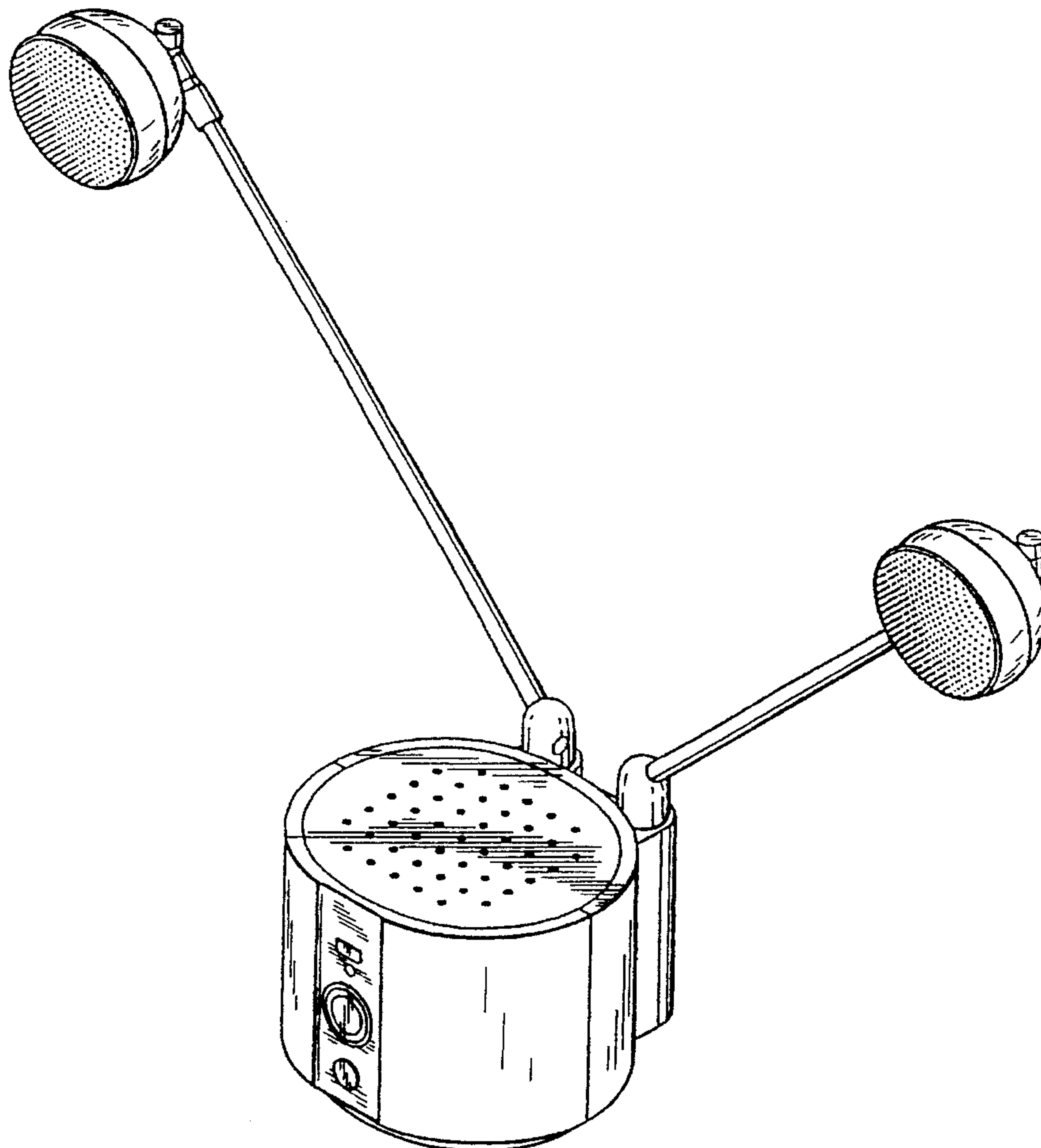
FIG. 7 is a rear view of the combined amplifier and speakers.

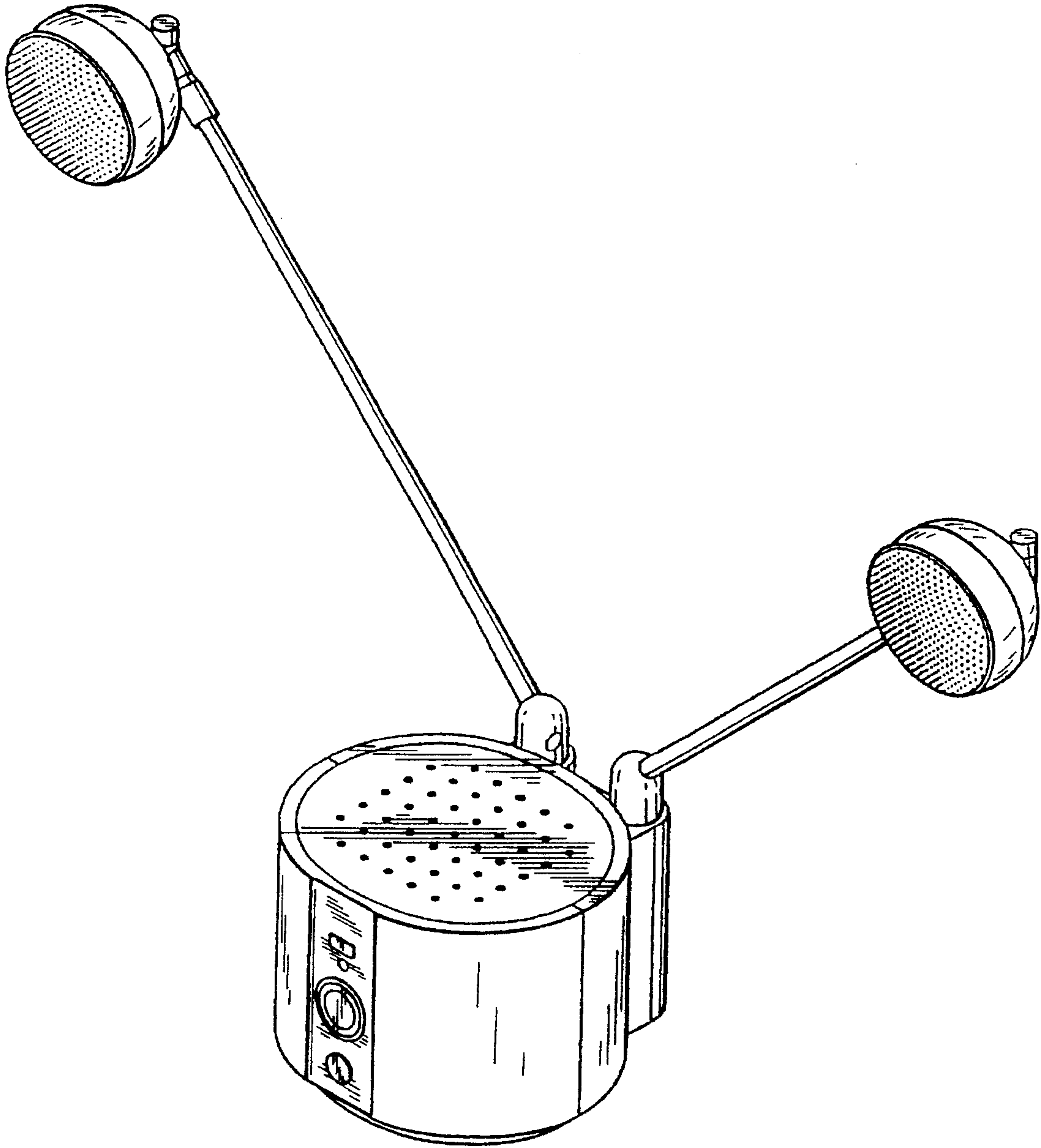
[56] **References Cited**

**U.S. PATENT DOCUMENTS**

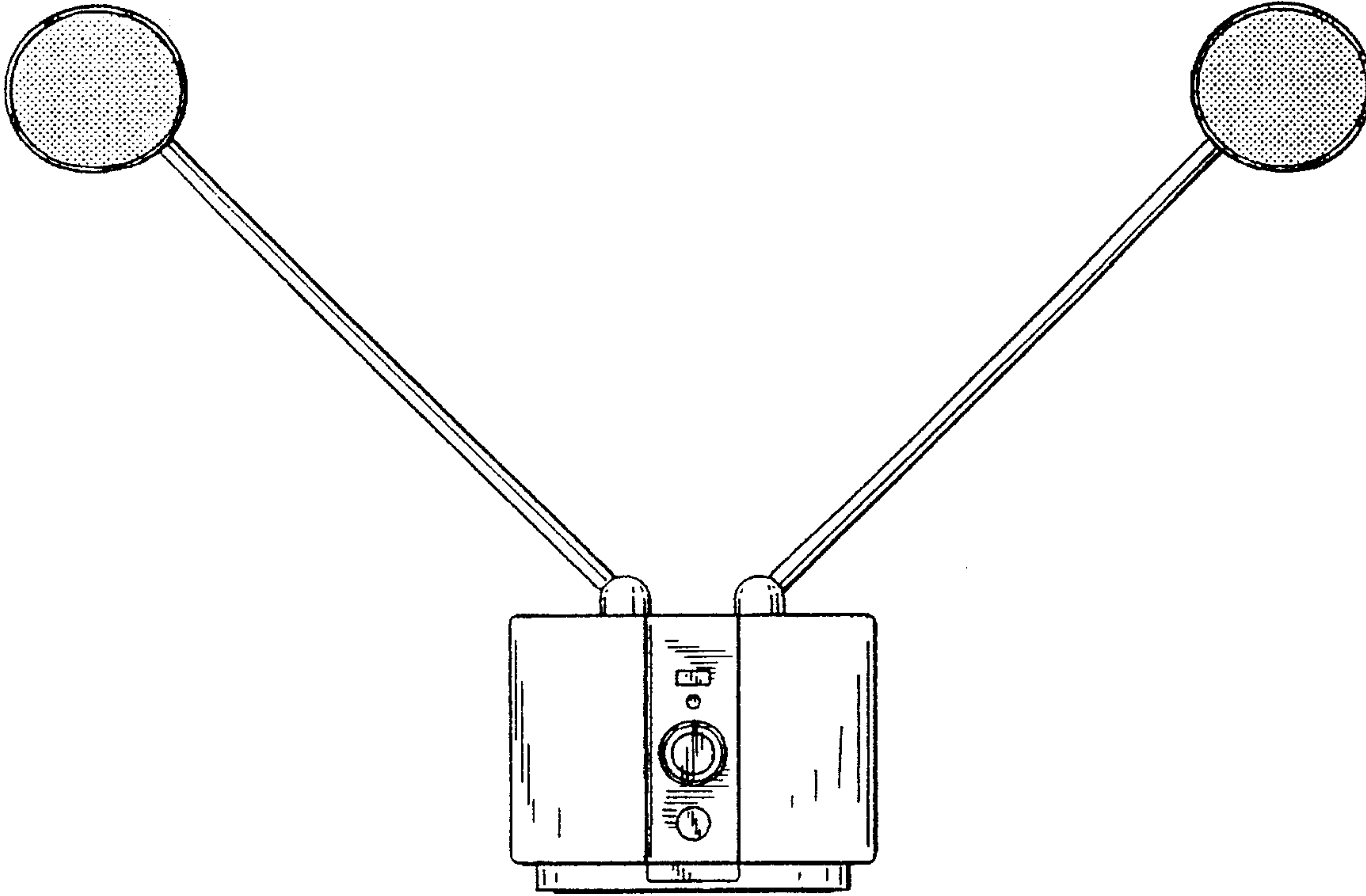
D. 229,348	11/1973	Ueda et al.	.....	D14/126
D. 308,372	6/1990	Saito et al.	.....	D14/126
D. 339,584	9/1993	Miyai	.....	D14/156
D. 356,568	3/1995	Ichikawa	.....	D14/209
4,691,383	9/1987	DeMars	.....	455/350 X

**1 Claim, 4 Drawing Sheets**

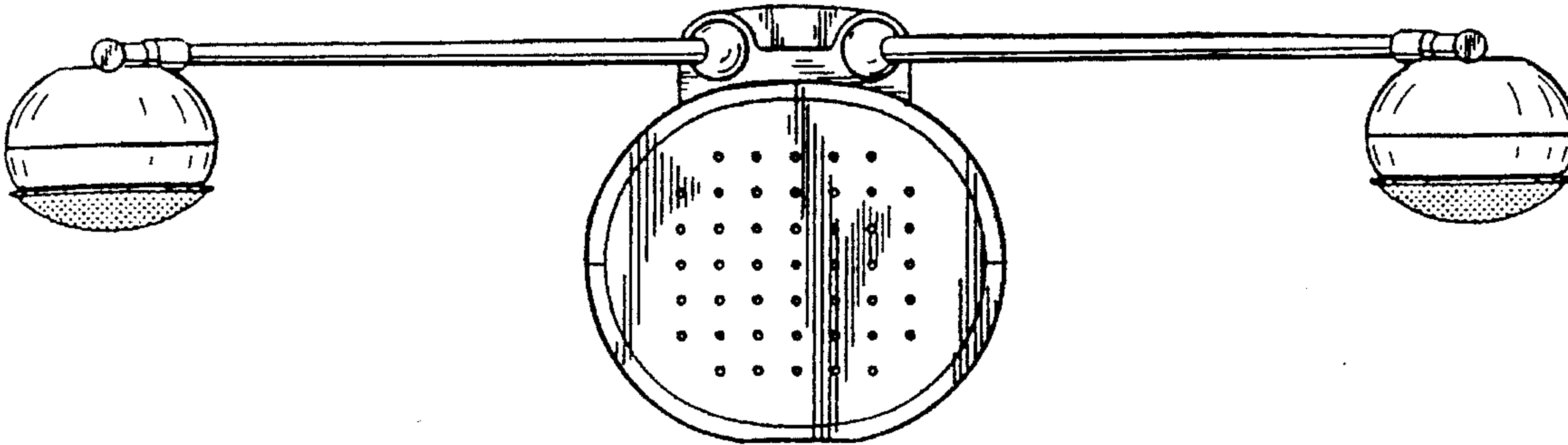




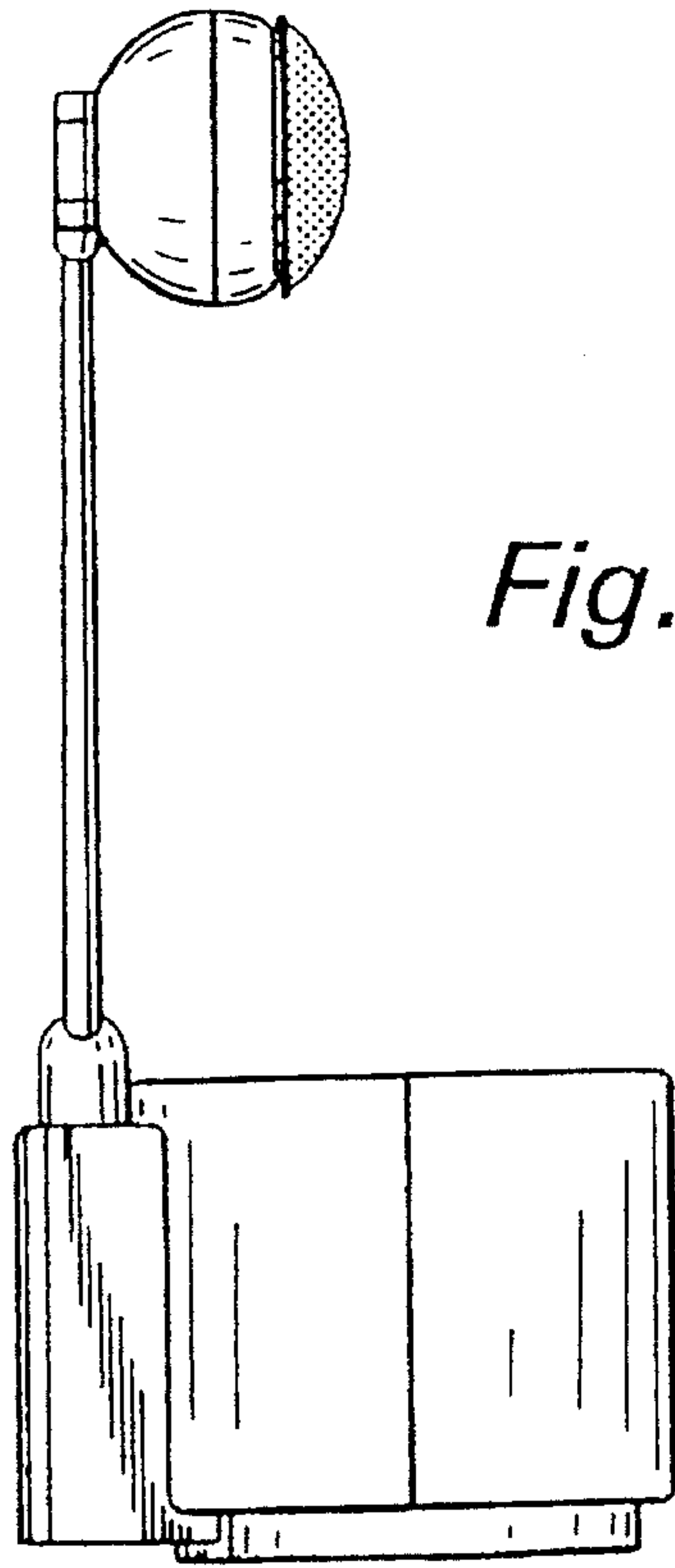
*Fig. 1*



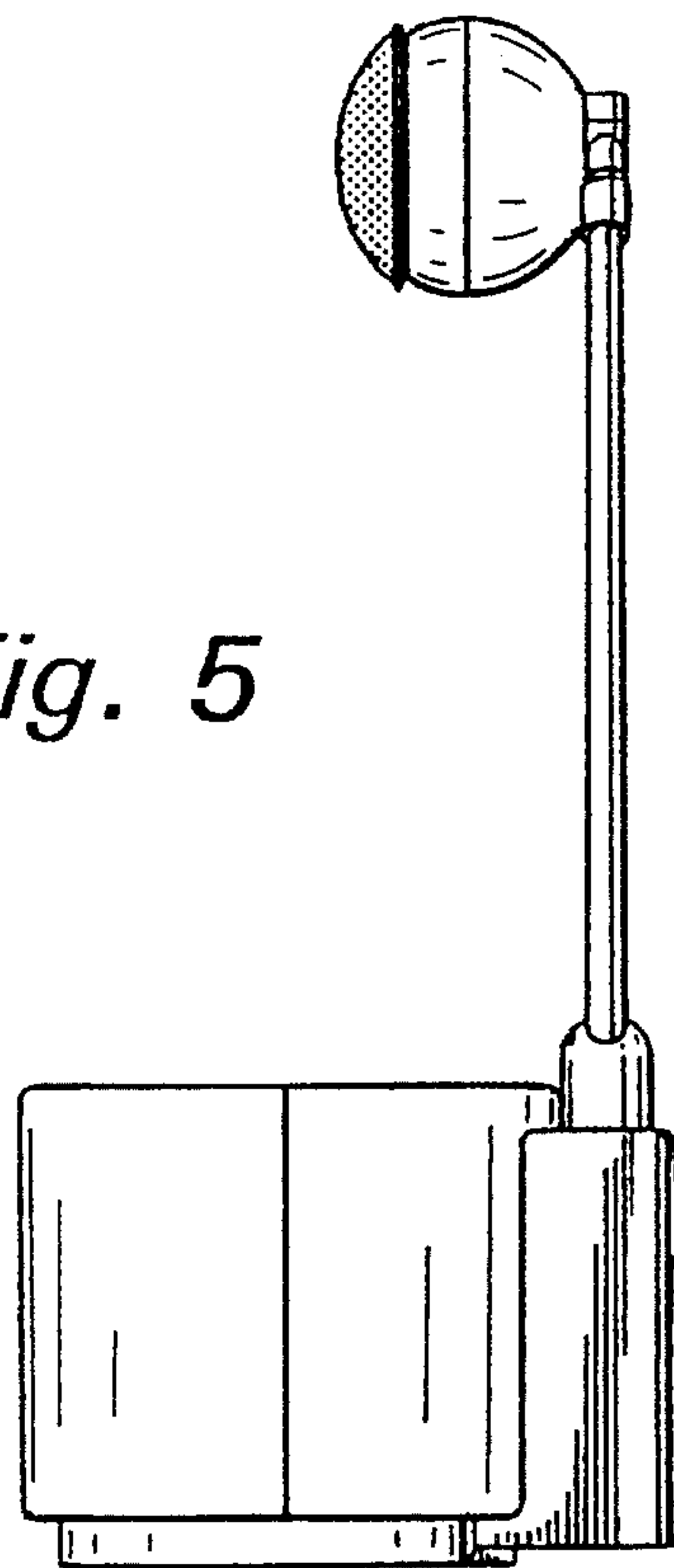
*Fig. 2*



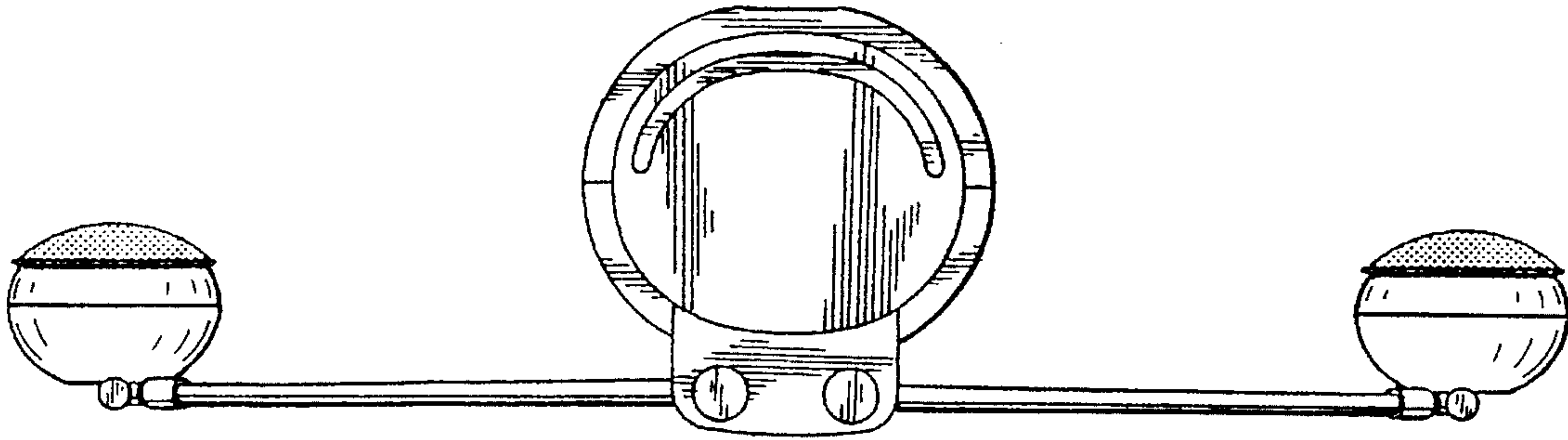
*Fig. 3*



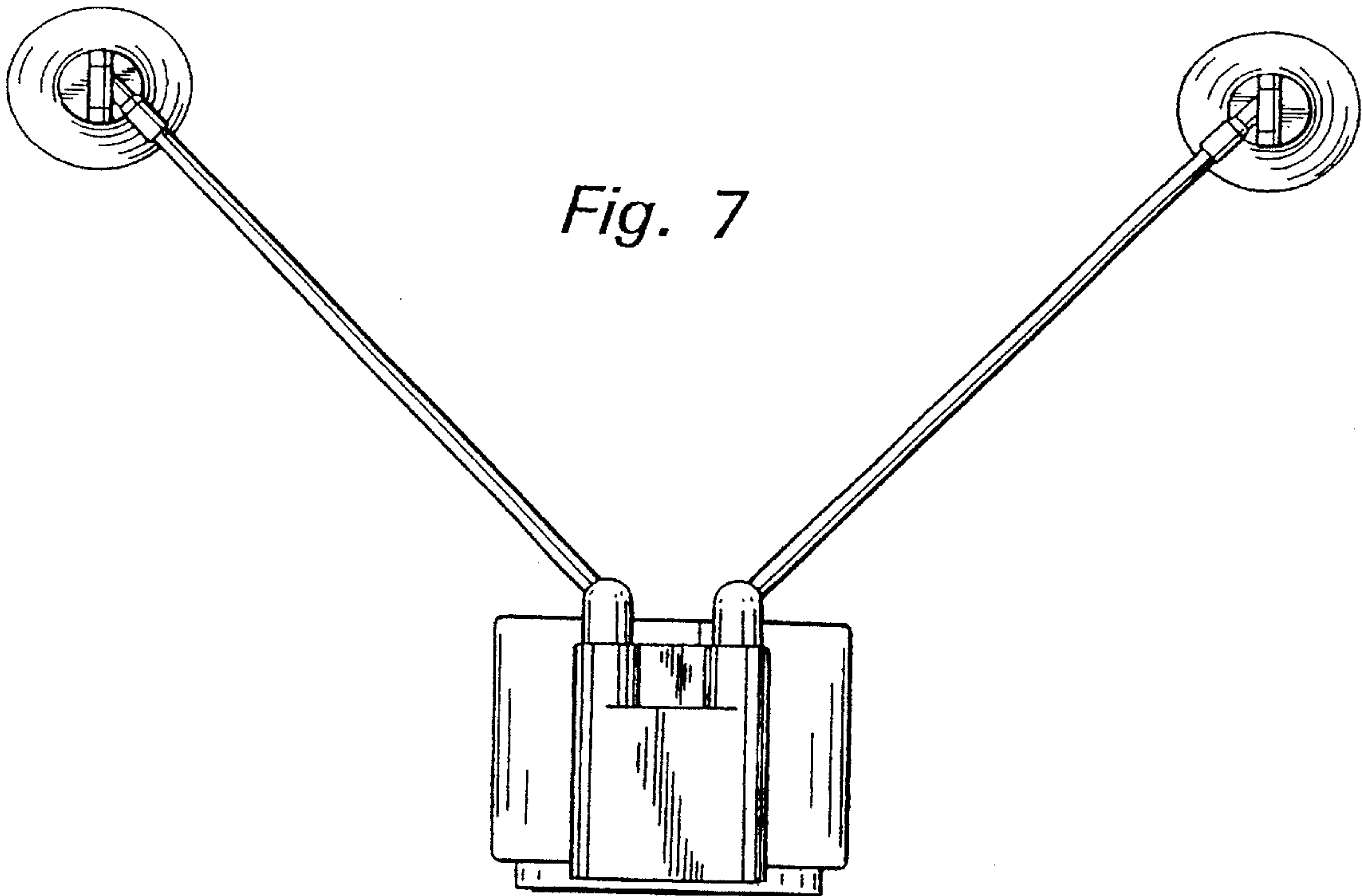
*Fig. 4*



*Fig. 5*



*Fig. 6*



*Fig. 7*