



US00D369776S

# United States Patent [19]

[11] Patent Number: **Des. 369,776**

**Kraft et al.**

[45] Date of Patent: **\*\*May 14, 1996**

[54] **PASSENGER AIRCRAFT**

2,738,148 3/1956 Stulen .  
3,191,888 6/1965 Sklenka .  
3,807,665 4/1974 Coombe .

[75] Inventors: **Roger E. Kraft**, Ft. Scott; **Jeffrey D. Ackland**, Shawnee; **Harold E. Kraft**, Ft. Scott, all of Kans.; **Martin Hollmann**, Monterrey, Calif.

### FOREIGN PATENT DOCUMENTS

643974 9/1928 France .  
875648 9/1942 France .  
342987 9/1936 Italy .  
507714 6/1939 United Kingdom .  
516013 12/1939 United Kingdom .  
1045209 10/1966 United Kingdom .

[73] Assignee: **Starkraft, Inc.**, Ft. Scott, Kans.

[\*\*] Term: **14 Years**

[21] Appl. No.: **34,229**

### OTHER PUBLICATIONS

[22] Filed: **Jan. 30, 1995**

Private Pilot, Aug. 1992, article by Budd Davisson, pp. 20-29.  
AOPA Pilot, Aug. 1992, article by Marc E. Cook, pp. 42-49.  
AOPA Pilot, Apr. 1993, article by Thomas B. Haines, pp. 36-42.  
Flying, Mar. 1991, article by Peter Garrison, pp. 66-74.  
AOPA Pilot, Aug. 1991, article by Marc E. Cook, pp. 86-92.  
Private Pilot, Apr. 1992, article by Dennis Shattuck, pp. 36-41.

### Related U.S. Application Data

[63] Continuation-in-part of Ser. No. 12,346, Oct. 12, 1993, Pat. No. Des. 354,936, and a continuation-in-part of Ser. No. 114,192, Aug. 30, 1993, abandoned.  
[52] **U.S. Cl.** ..... **D12/344**; D12/339  
[58] **Field of Search** ..... D12/319, 326, D12/337, 339, 344; 244/45 R, 45 A, 55, 91, 29

*Primary Examiner*—Kay H. Chin  
*Attorney, Agent, or Firm*—Hovey, Williams Timmons & Collins

### [56] References Cited

#### U.S. PATENT DOCUMENTS

D. 121,685 7/1940 Koss .  
D. 134,037 10/1942 Robitaille .  
D. 134,425 11/1942 McDonnell, Jr. .  
D. 135,696 5/1943 Duhamel .  
D. 144,020 3/1946 Altman .  
D. 239,522 4/1976 Wheatley .  
D. 280,892 10/1985 Mazzoni .  
D. 326,255 5/1992 Graham et al. .... D12/331  
D. 348,245 6/1994 Blum ..... D12/331  
D. 354,936 1/1995 Kraft et al. .... D12/344  
1,203,558 10/1916 Gallaudet .  
1,551,983 9/1925 Dornier .  
1,648,818 11/1927 Mannick .  
1,758,866 5/1930 Sweet .  
1,842,055 1/1932 Stout .  
1,854,364 4/1932 Bellanca .  
1,858,761 5/1932 Bellanca .  
1,858,762 5/1932 Bellanca .  
2,140,783 12/1938 Bellanca .  
2,395,513 2/1946 Stalker .  
2,691,494 10/1954 Custer .

### [57] CLAIM

The ornamental design for a passenger aircraft, as shown and described.

### DESCRIPTION

FIG. 1 is a top plan view of a first embodiment showing our ornamental design for a passenger aircraft;  
FIG. 2 is a right side elevational view thereof with the landing gear extended;  
FIG. 3 is a left side elevational view thereof with the landing gear extended;  
FIG. 4 is a bottom plan view thereof with the landing gear extended;  
FIG. 5 is a rear elevational view thereof with the landing gear extended, the rear view of the subsequently described second embodiment being identical thereto;  
FIG. 6 is a front elevational view thereof with the landing gear extended, the front view of the subsequently described second embodiment being identical thereto;

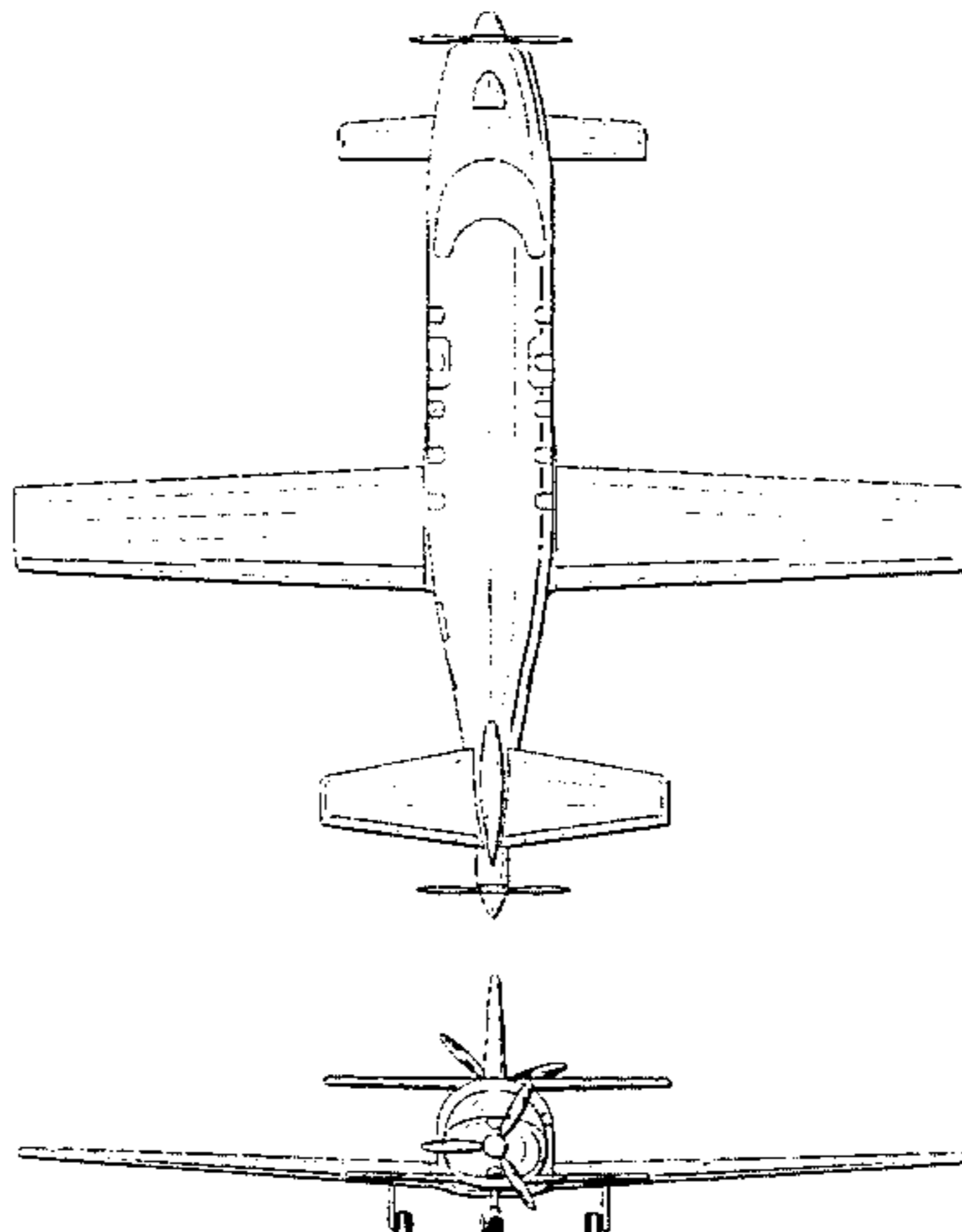


FIG. 7 is a rear elevational view thereof with the landing gear retracted, the rear view of the subsequently described second embodiment being identical thereto;

FIG. 8 is a front elevational view thereof with the landing gear retracted, the front view of the subsequently described second embodiment being identical thereto;

FIG. 9 is a right side elevational view of the first embodiment of the present invention with the landing gear retracted;

FIG. 10 is a left side elevational view of the first embodiment of the present invention with the landing gear retracted;

FIG. 11 is a top plan view of a second embodiment of our ornamental design for a passenger aircraft;

FIG. 12 is a right side elevational view of the second embodiment with the landing gear extended;

FIG. 13 is a left side elevational view of the second embodiment with the landing gear extended;

FIG. 14 is a bottom plan view of the second embodiment with the landing gear extended;

FIG. 15 is a rear elevational view of the second embodiment with the landing gear extended;

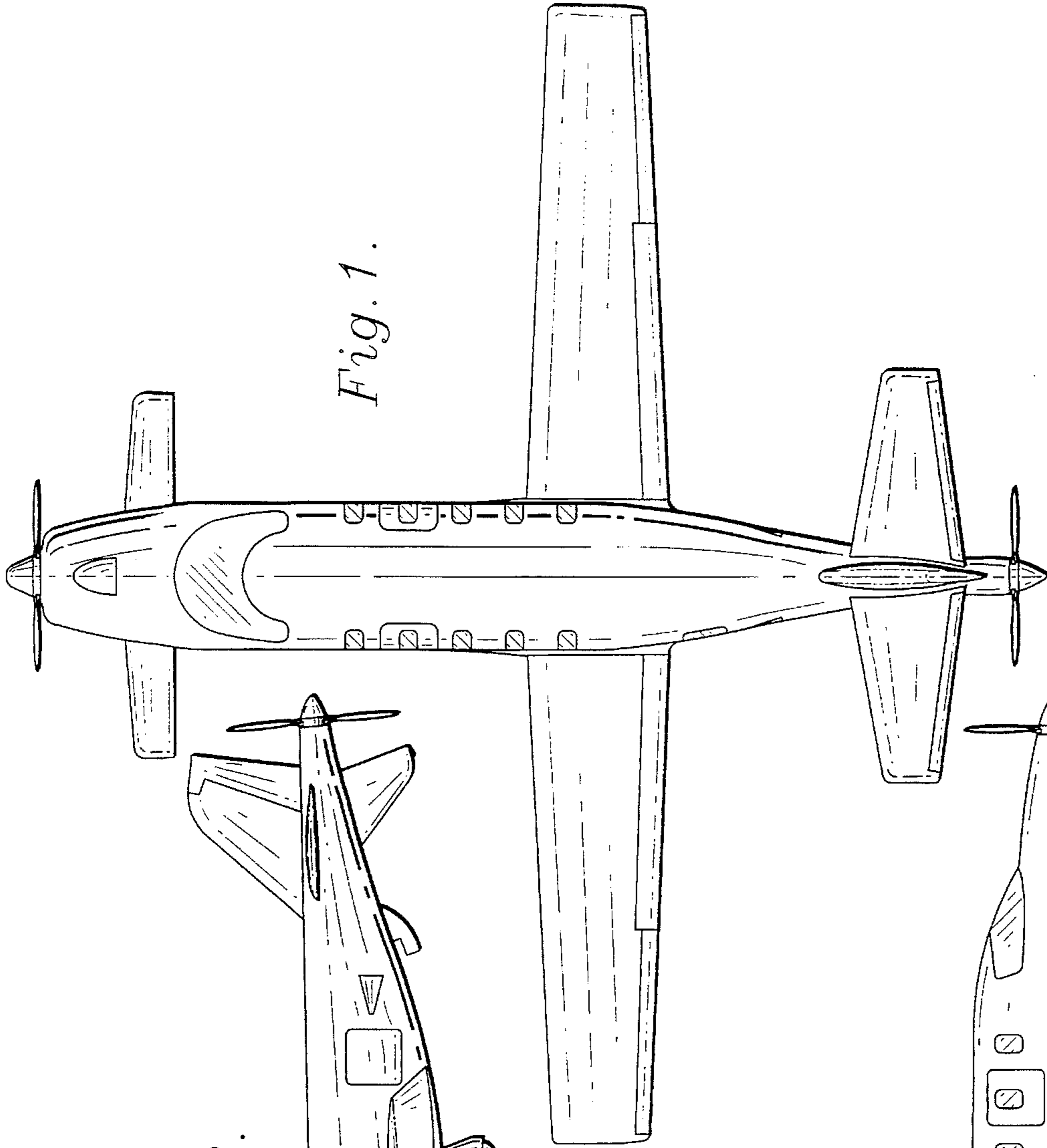
FIG. 16 is a rear elevational view of the second embodiment with the landing gear retracted;

FIG. 17 is a right side elevational view of the second embodiment with the landing gear retracted;

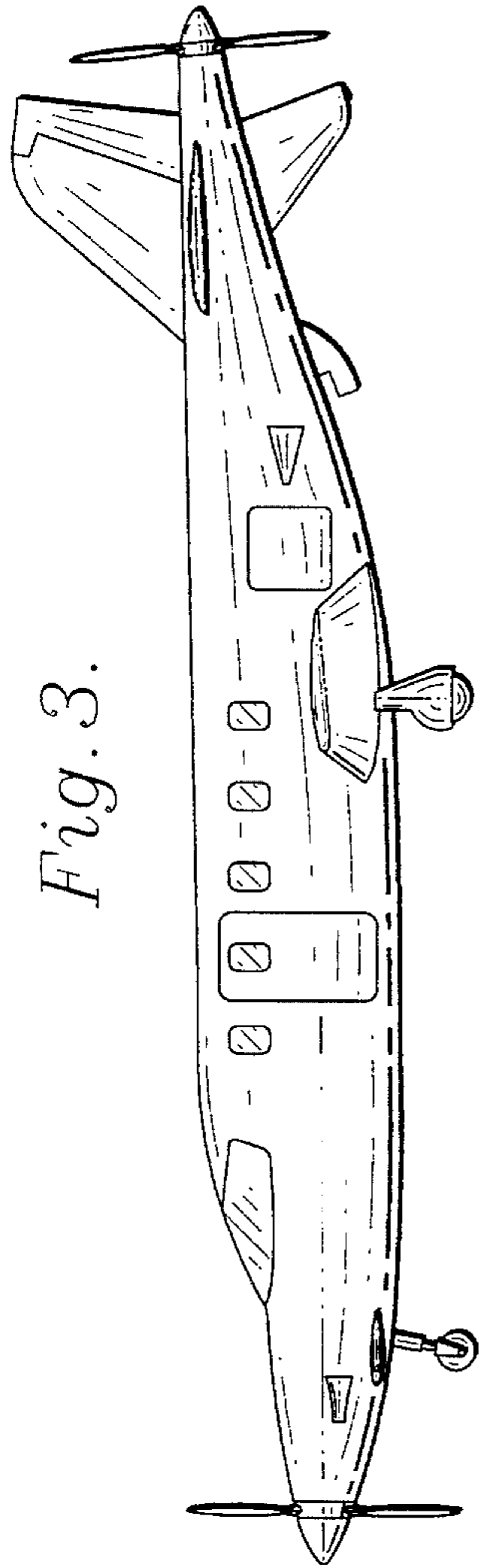
FIG. 18 is a left side elevational view of the second embodiment with the landing gear retracted; and,

FIG. 19 is a bottom plan view of the second embodiment with the landing gear retracted.

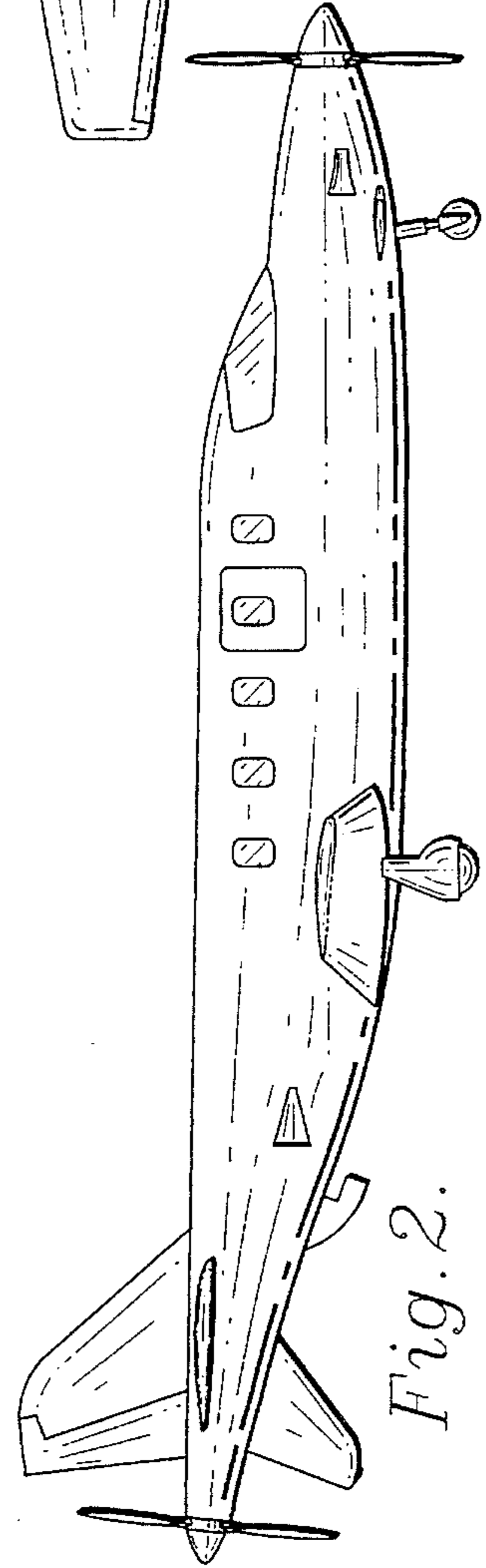
**1 Claim, 7 Drawing Sheets**



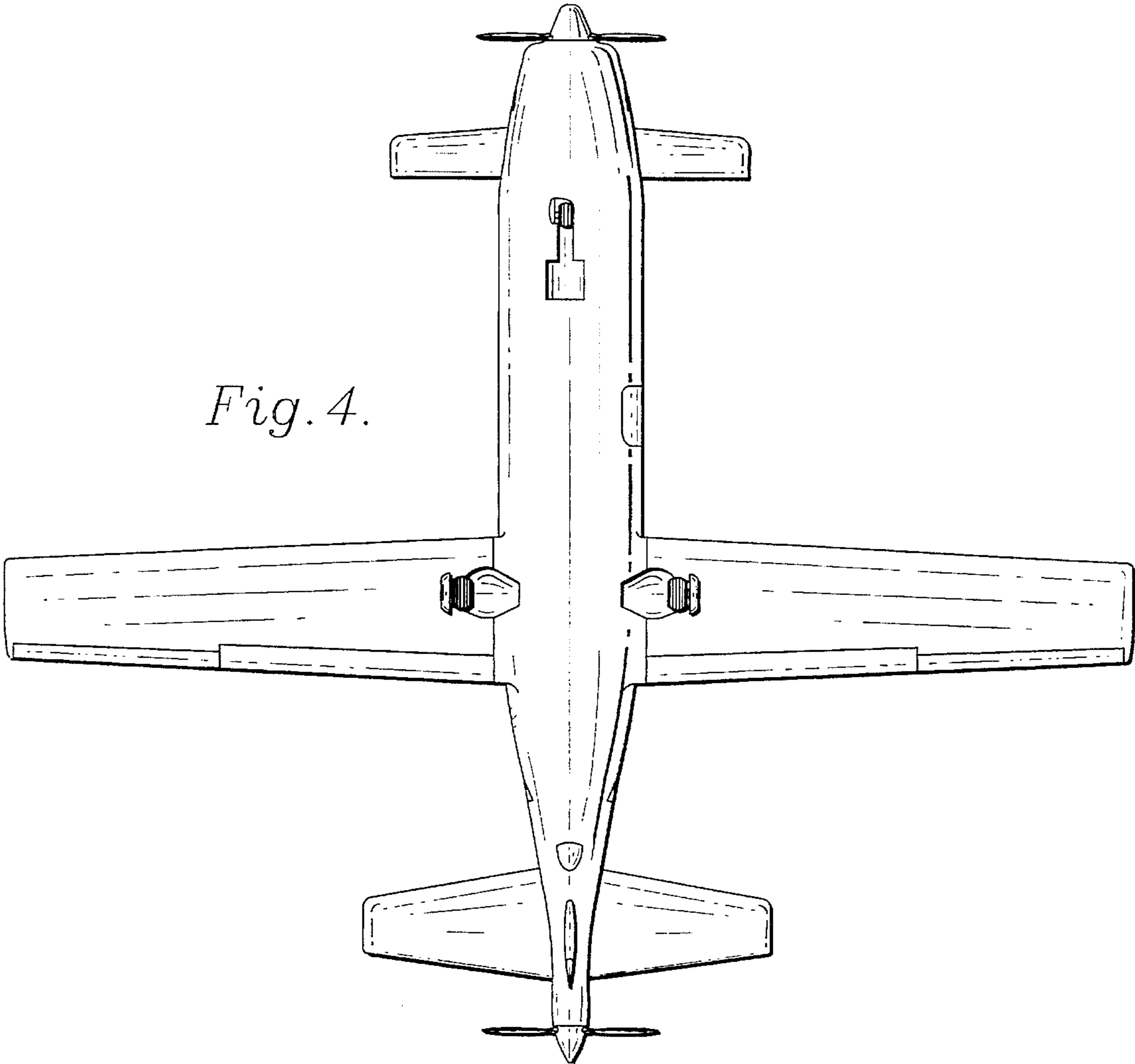
*Fig. 1.*



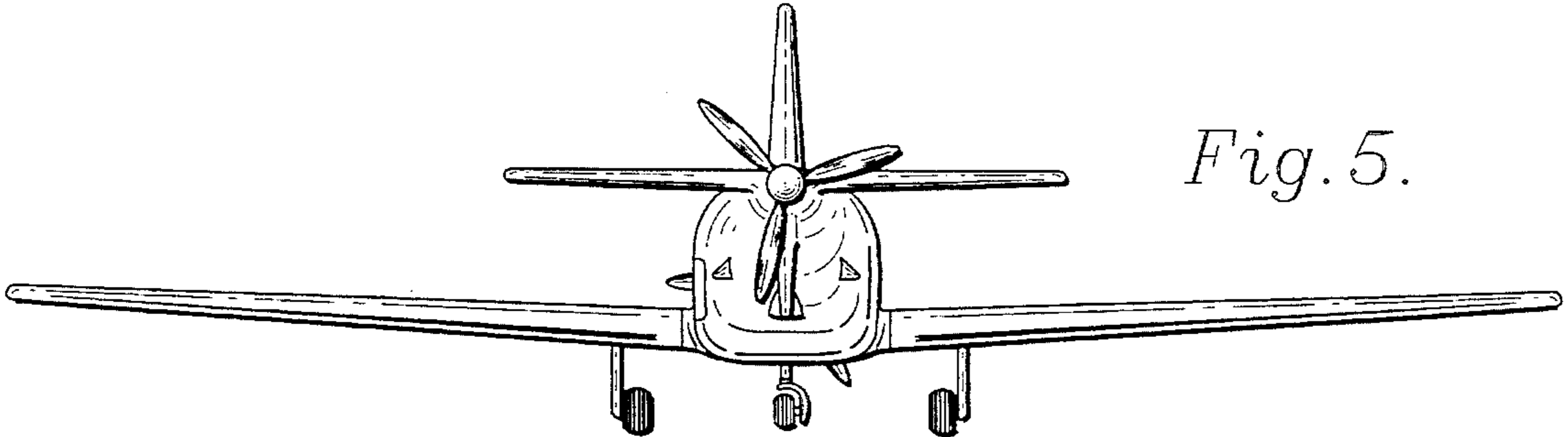
*Fig. 3.*



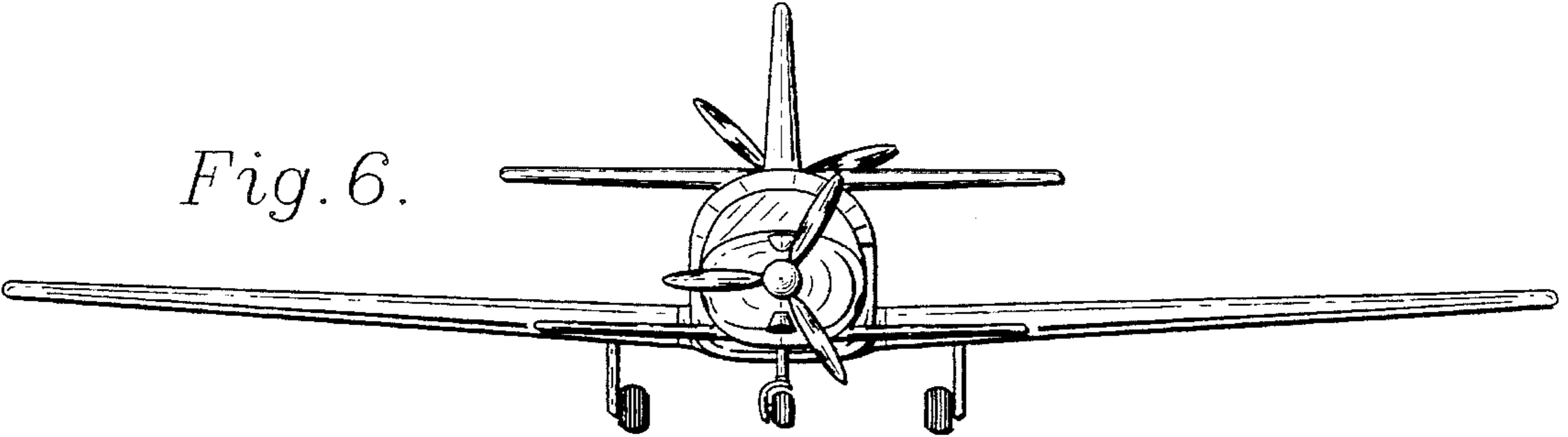
*Fig. 2.*



*Fig. 4.*

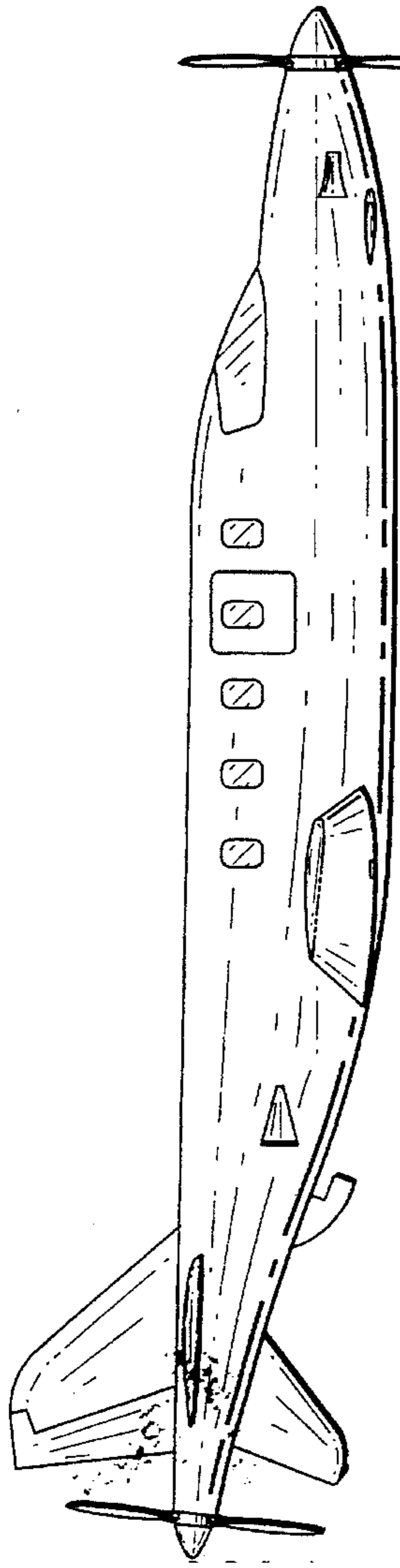


*Fig. 5.*

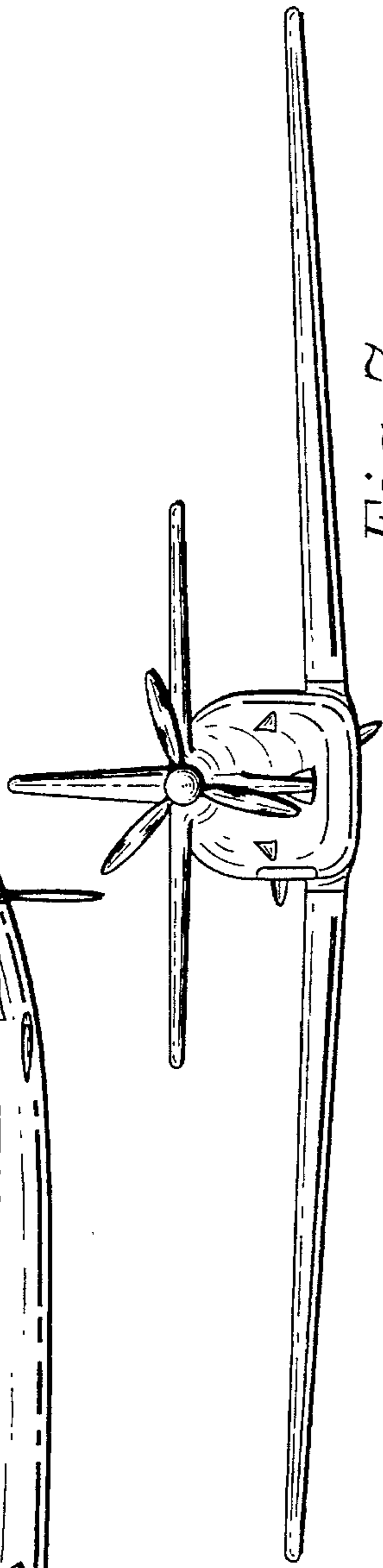


*Fig. 6.*

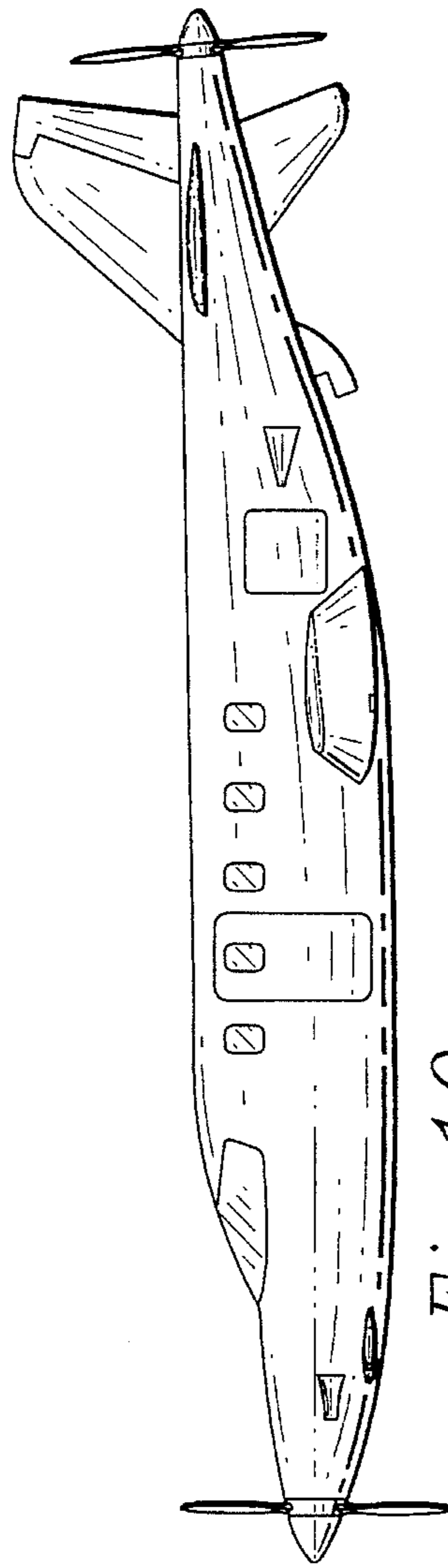




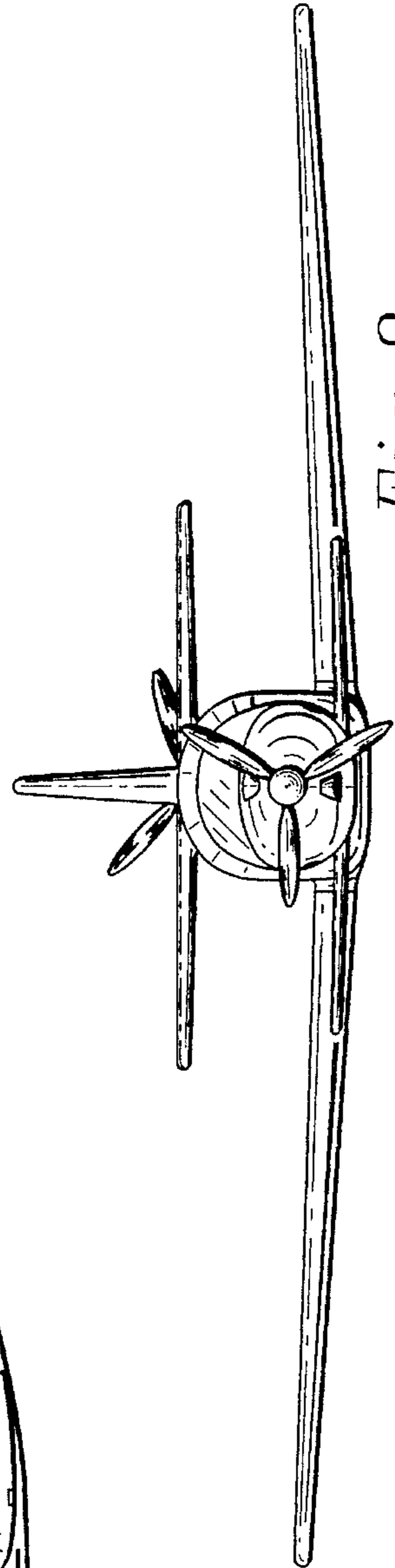
*Fig. 9.*



*Fig. 7.*



*Fig. 10.*



*Fig. 8.*

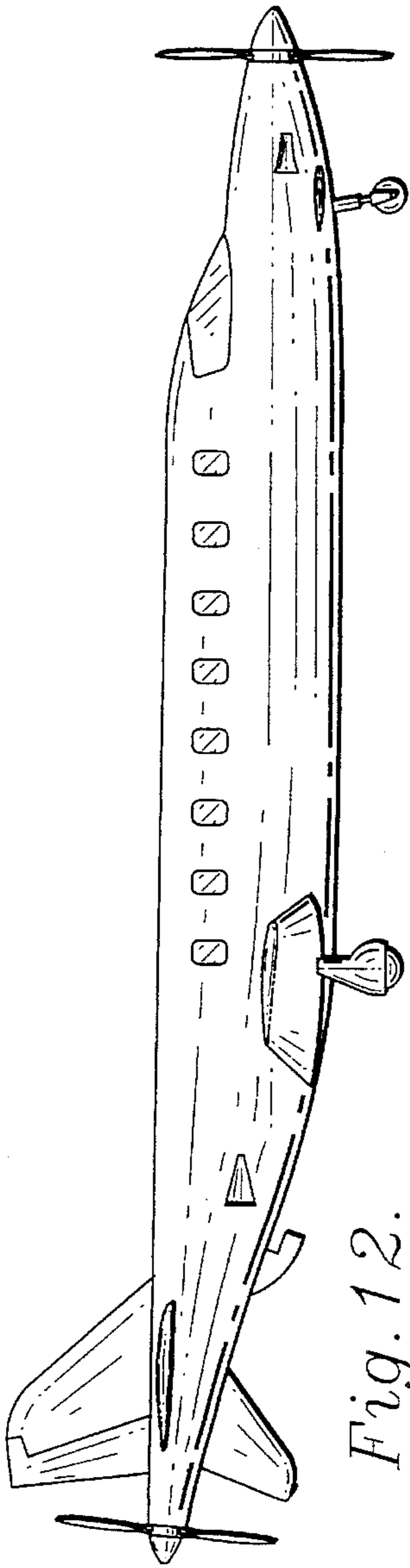


Fig. 12.

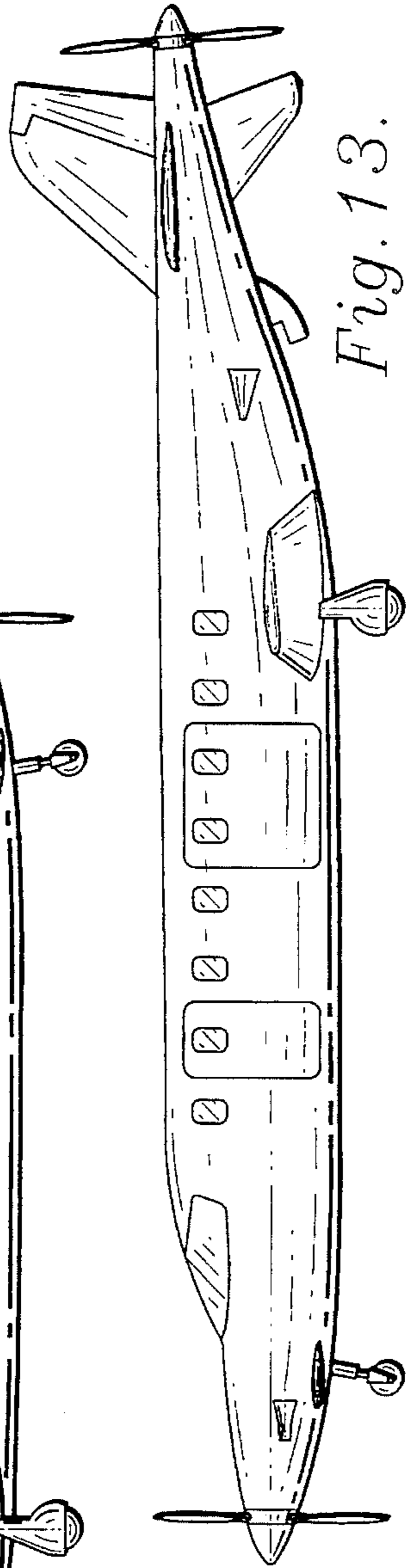


Fig. 13.

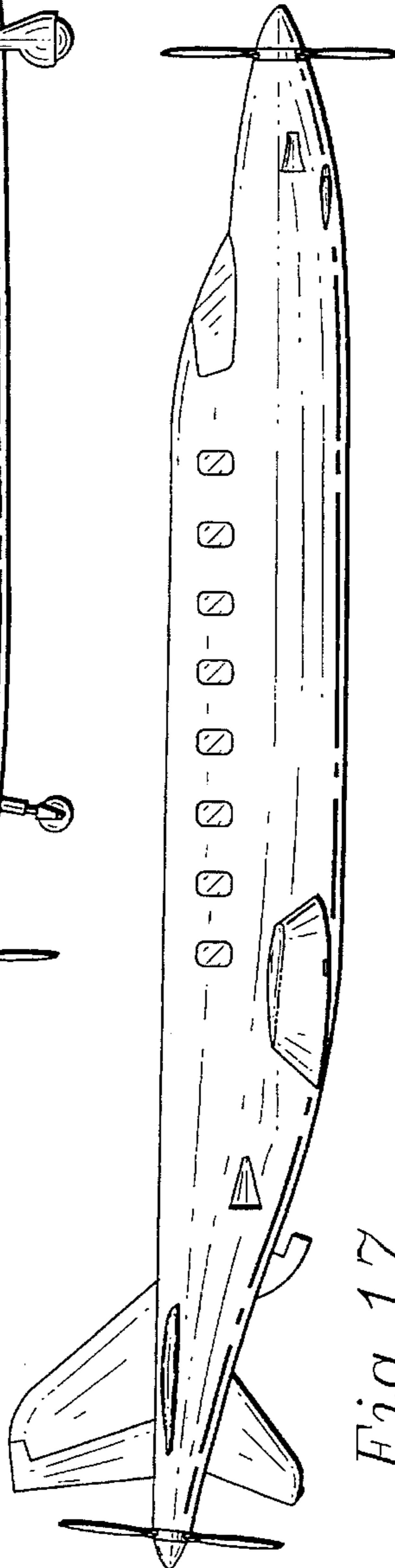


Fig. 17.

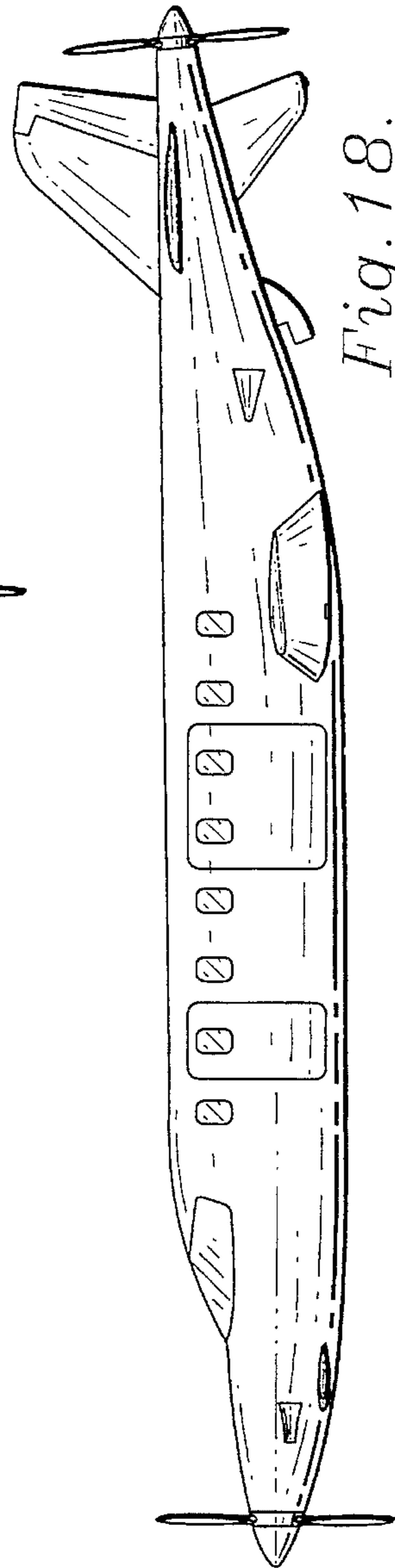
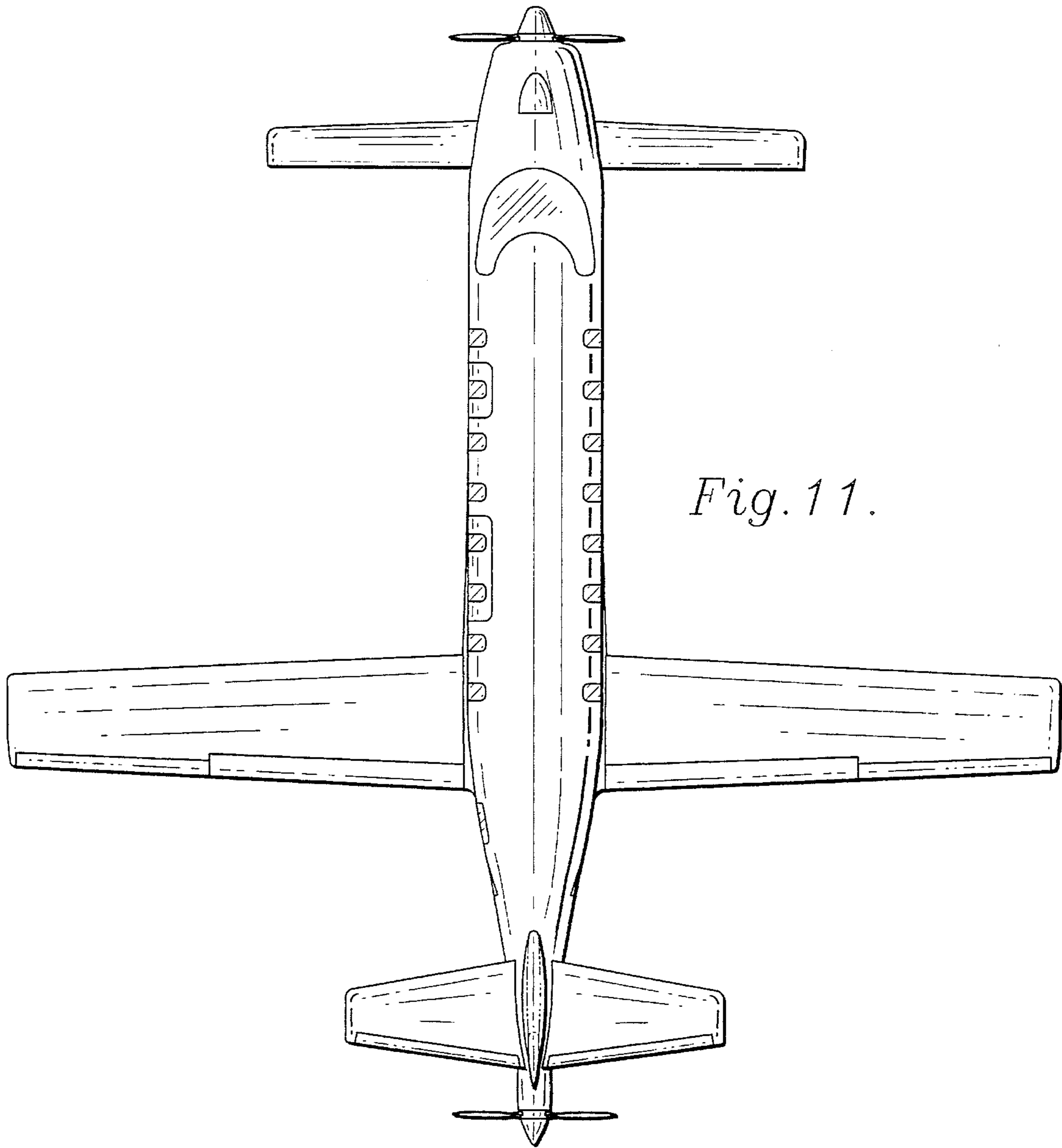
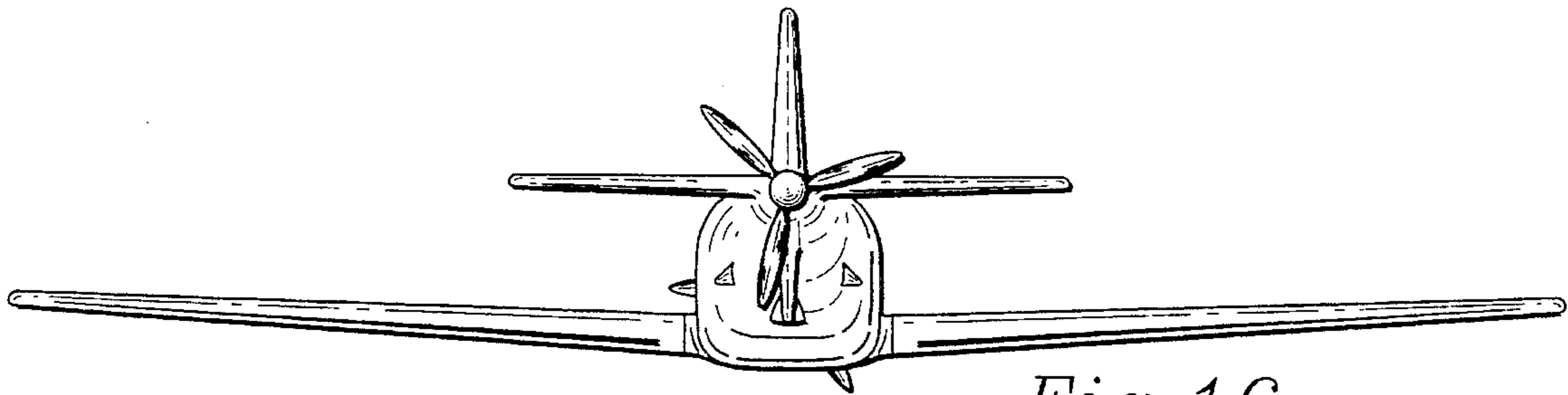


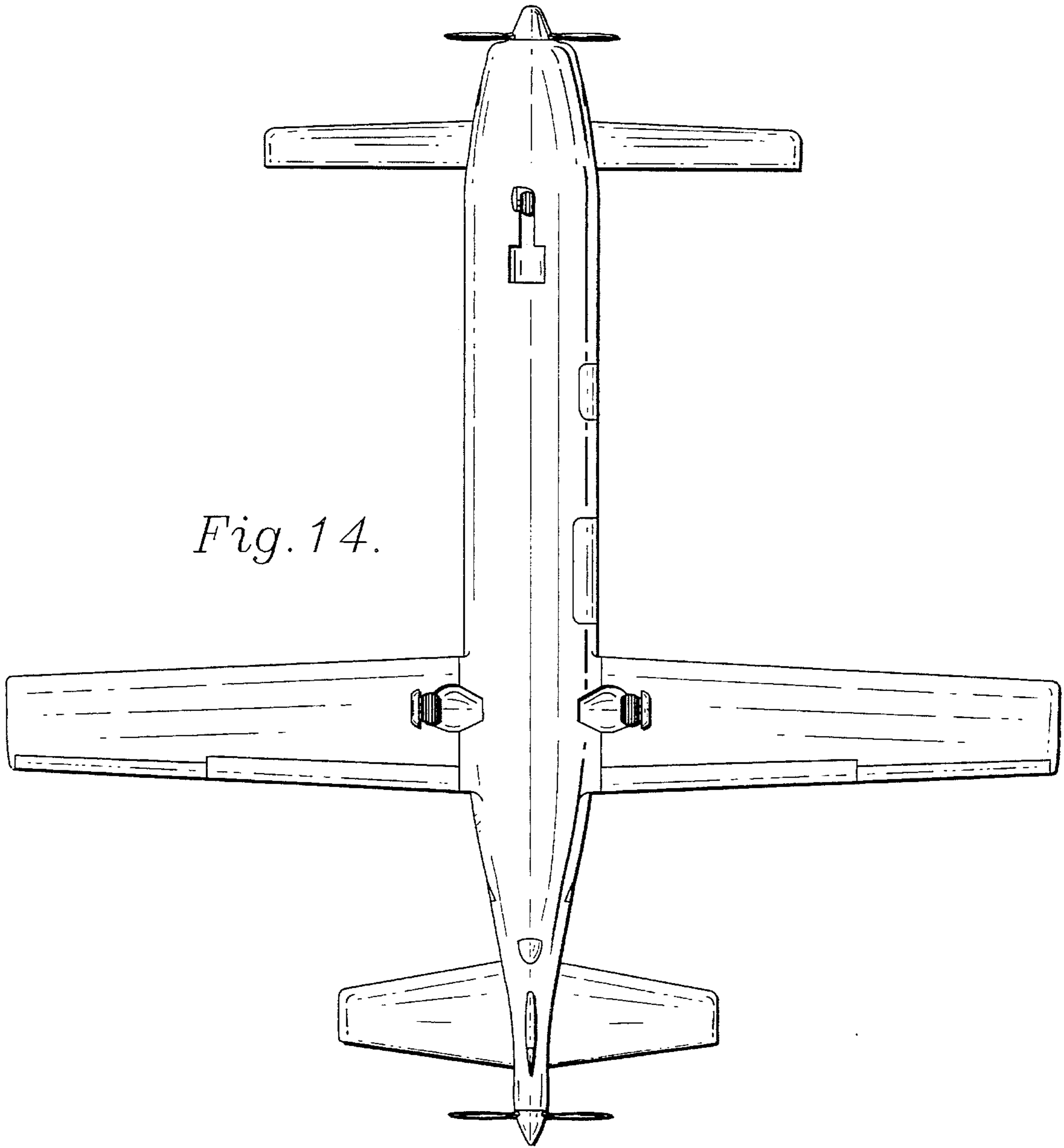
Fig. 18.



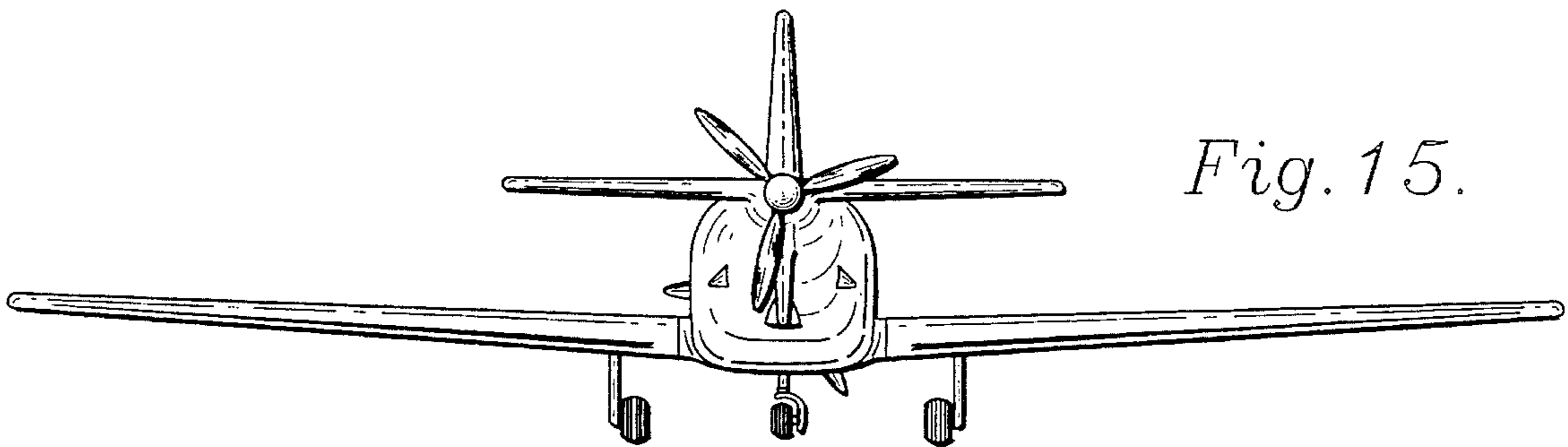
*Fig. 11.*



*Fig. 16.*



*Fig. 14.*



*Fig. 15.*



