



US00D369762S

# United States Patent [19]

Molzon et al.

[11] Patent Number: **Des. 369,762**

[45] Date of Patent: **\*\*May 14, 1996**

[54] **GOLF CAR**

[75] Inventors: **William R. Molzon**, Clarkston, Mich.;  
**James M. Criscuolo**, Martinez, Ga.

[73] Assignee: **Textron Inc.**, Providence, R.I.

[\*\*] Term: **14 Years**

[21] Appl. No.: **29,859**

[22] Filed: **Oct. 18, 1994**

### Related U.S. Application Data

[63] Continuation-in-part of Ser. No. 17,534, Jan. 14, 1994, which is a continuation-in-part of Ser. No. 886,444, May 20, 1992, Pat. No. Des. 345,717, and Ser. No. 886,445, May 20, 1992, Pat. No. Des. 345,718.

[52] U.S. Cl. .... **D12/16**

[58] Field of Search ..... D12/16; 280/DIG. 5;  
296/186

### [56] References Cited

#### U.S. PATENT DOCUMENTS

D. 255,558	6/1980	Ekuan	.....	D12/16
D. 320,580	10/1991	Kim	.....	D12/16
D. 326,831	6/1992	Lanius et al.	.....	D12/16
D. 345,717	4/1994	Molzon et al.	.....	D12/16
D. 345,718	4/1994	Molzon et al.	.....	D12/16

4,037,614	7/1977	Hines et al.	.....	135/5 A
4,098,536	7/1978	Mills	.....	296/78.1
4,334,692	6/1982	Lynch	.....	280/79.1 A
4,533,013	8/1985	Hightower	.....	180/210
4,650,238	3/1987	Healey	.....	296/37.7
4,772,064	9/1988	Moore	.....	296/102
4,773,695	9/1988	Jones et al.	.....	296/77.1
5,094,500	3/1992	Maypole et al.	.....	296/102

### OTHER PUBLICATIONS

1990 E-Z-GO Textron Product Catalog, pp. 1, 6, 9, 14, 22, 23, 24.

*Primary Examiner*—Melody N. Brown  
*Attorney, Agent, or Firm*—Perman & Green

### [57] CLAIM

The ornamental design for a golf car, as shown and described.

### DESCRIPTION

FIG. 1 is a perspective view of a golf car showing our new design;  
FIG. 2 is a top plan view thereof;  
FIG. 3 is a side elevational view thereof, the opposite side being a mirror image;  
FIG. 4 is a front elevational view thereof; and,  
FIG. 5 is a rear elevational view thereof.

**1 Claim, 4 Drawing Sheets**

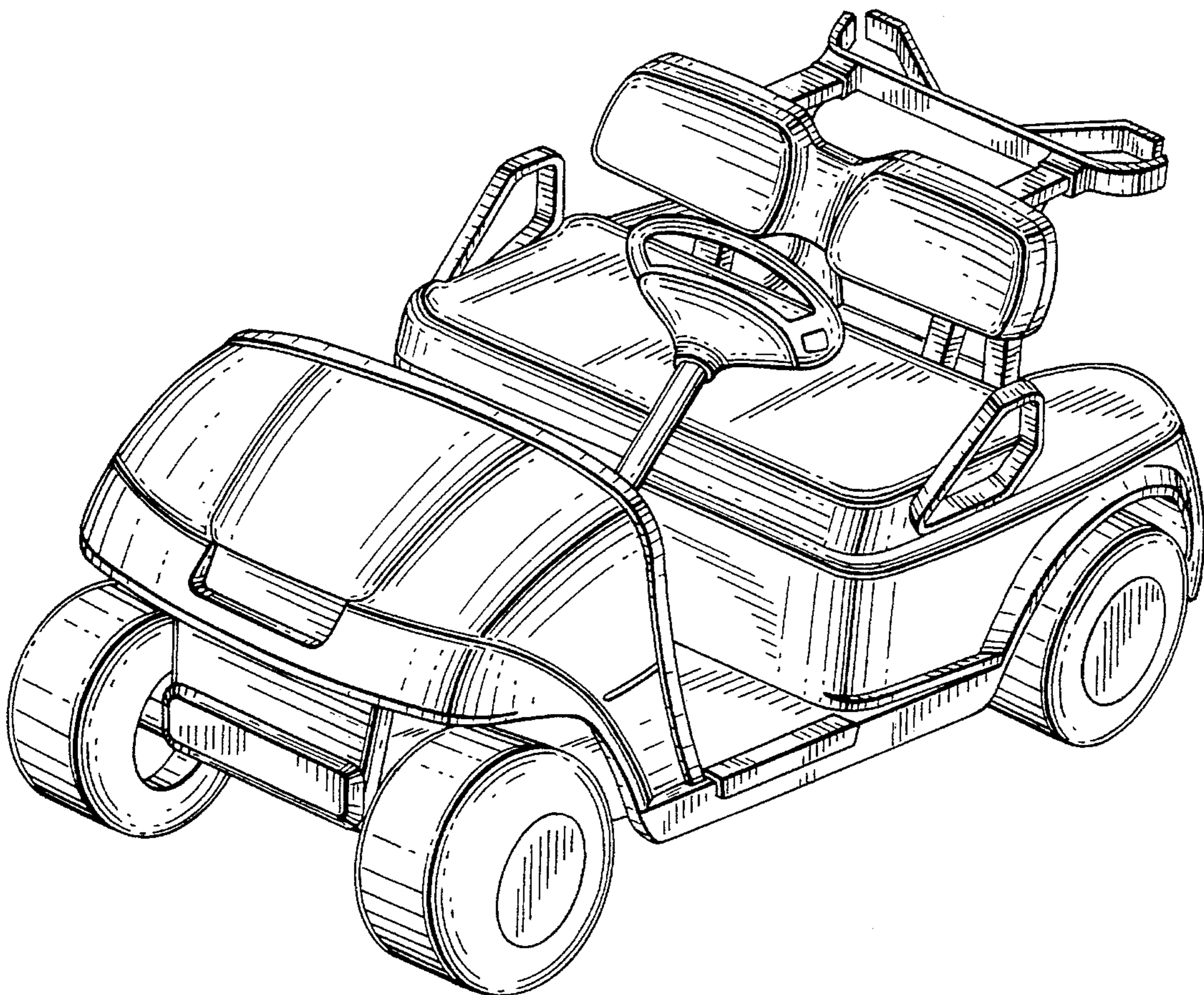

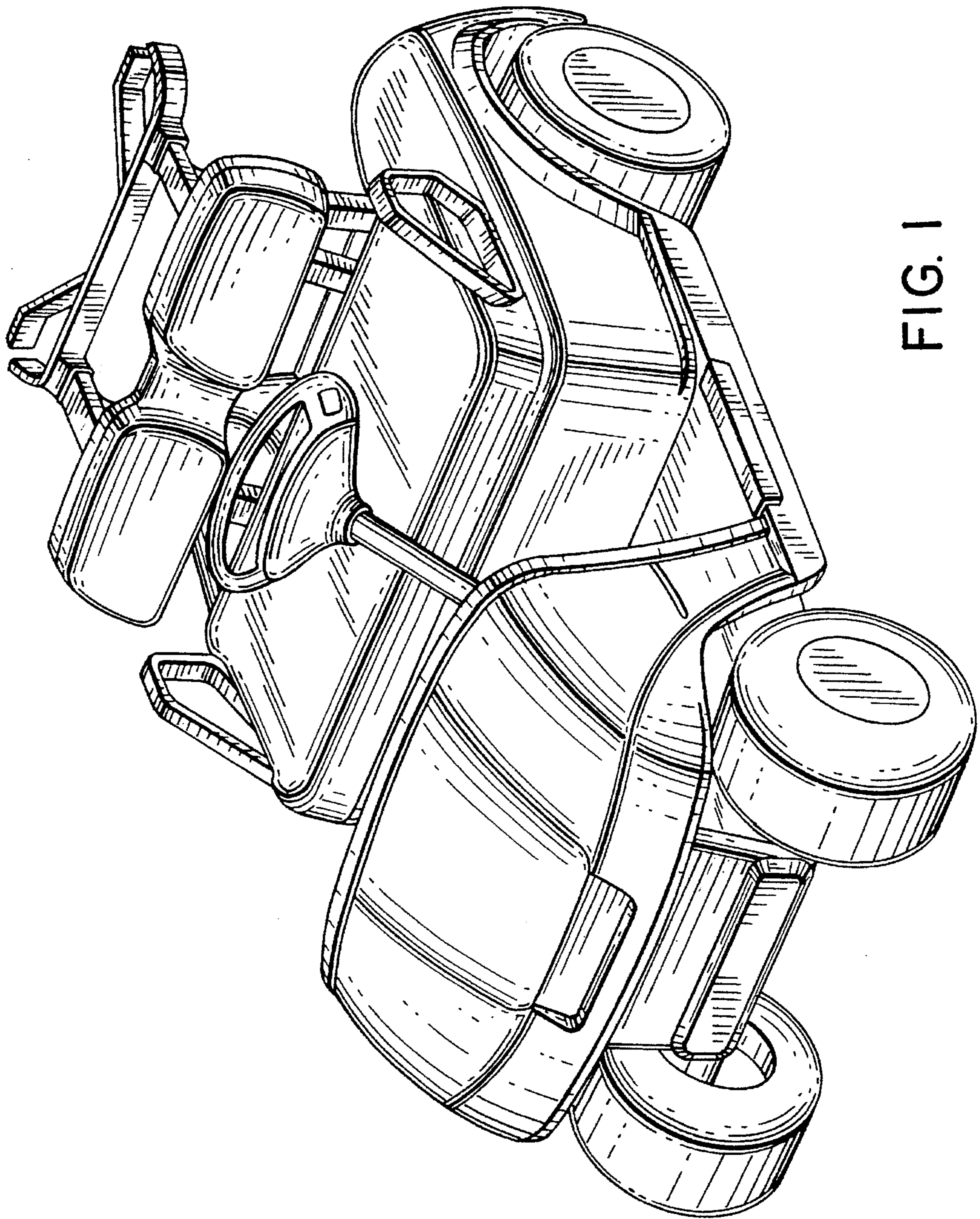

FIG. 1

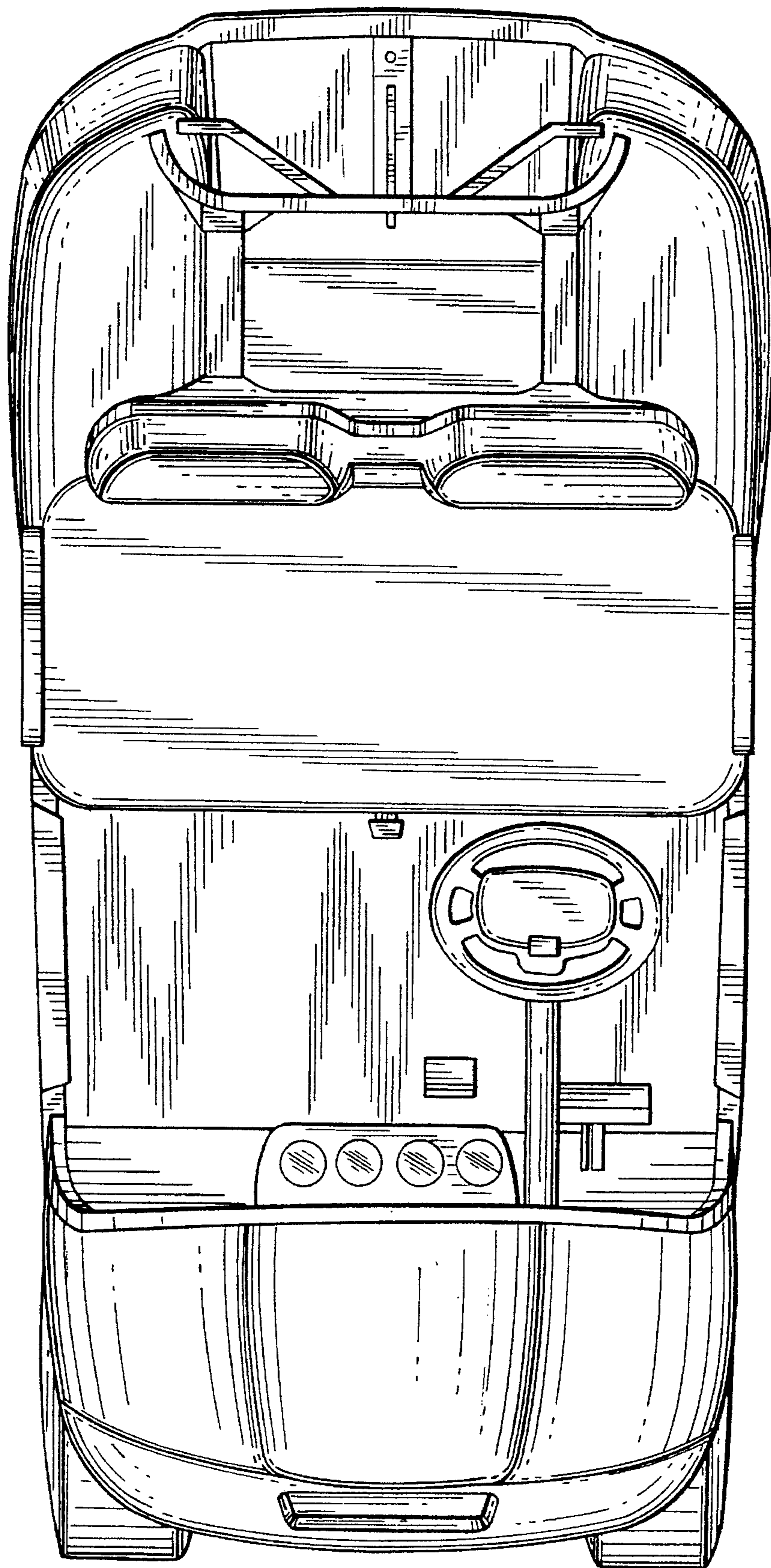

FIG. 2

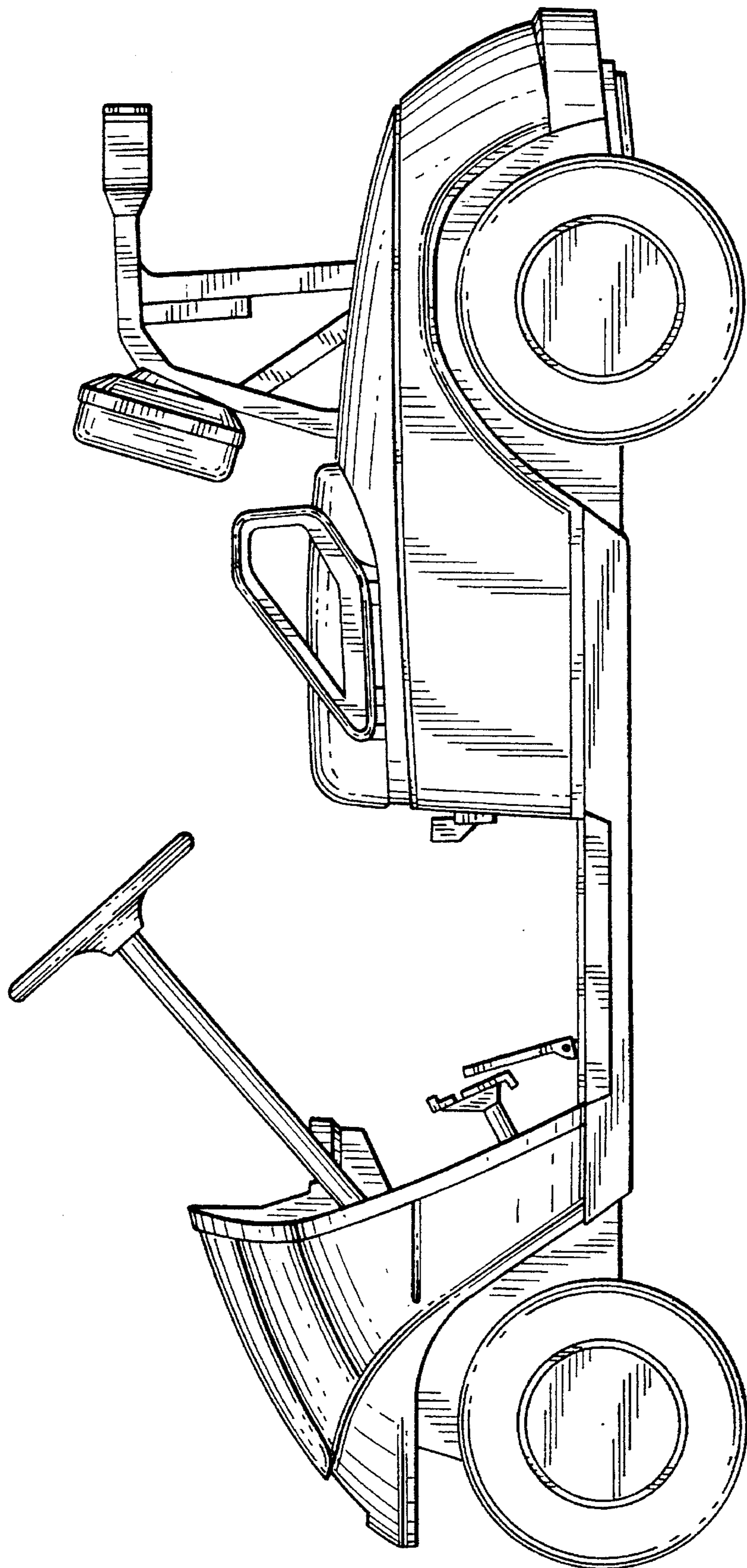

FIG. 3

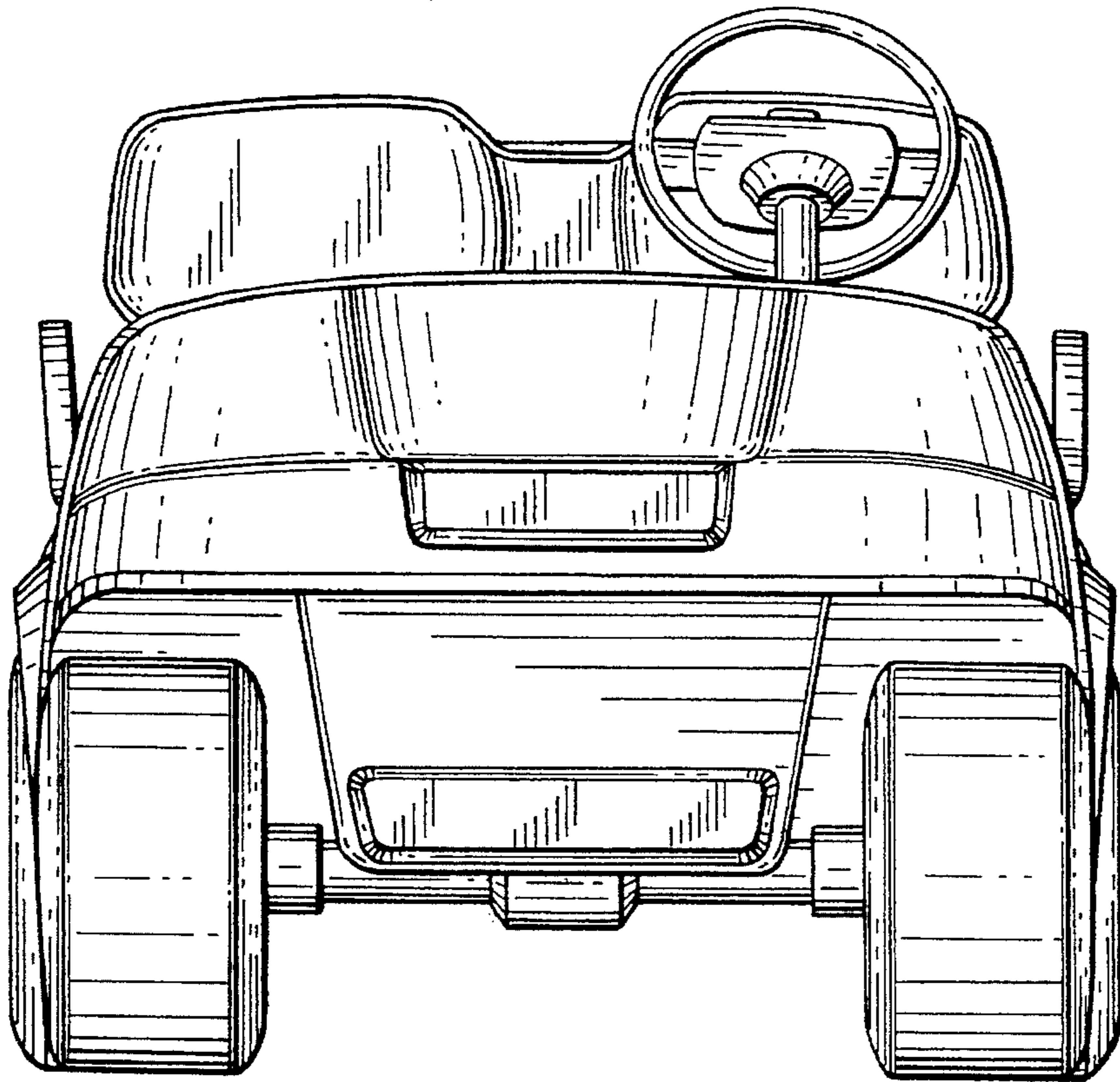

FIG. 4

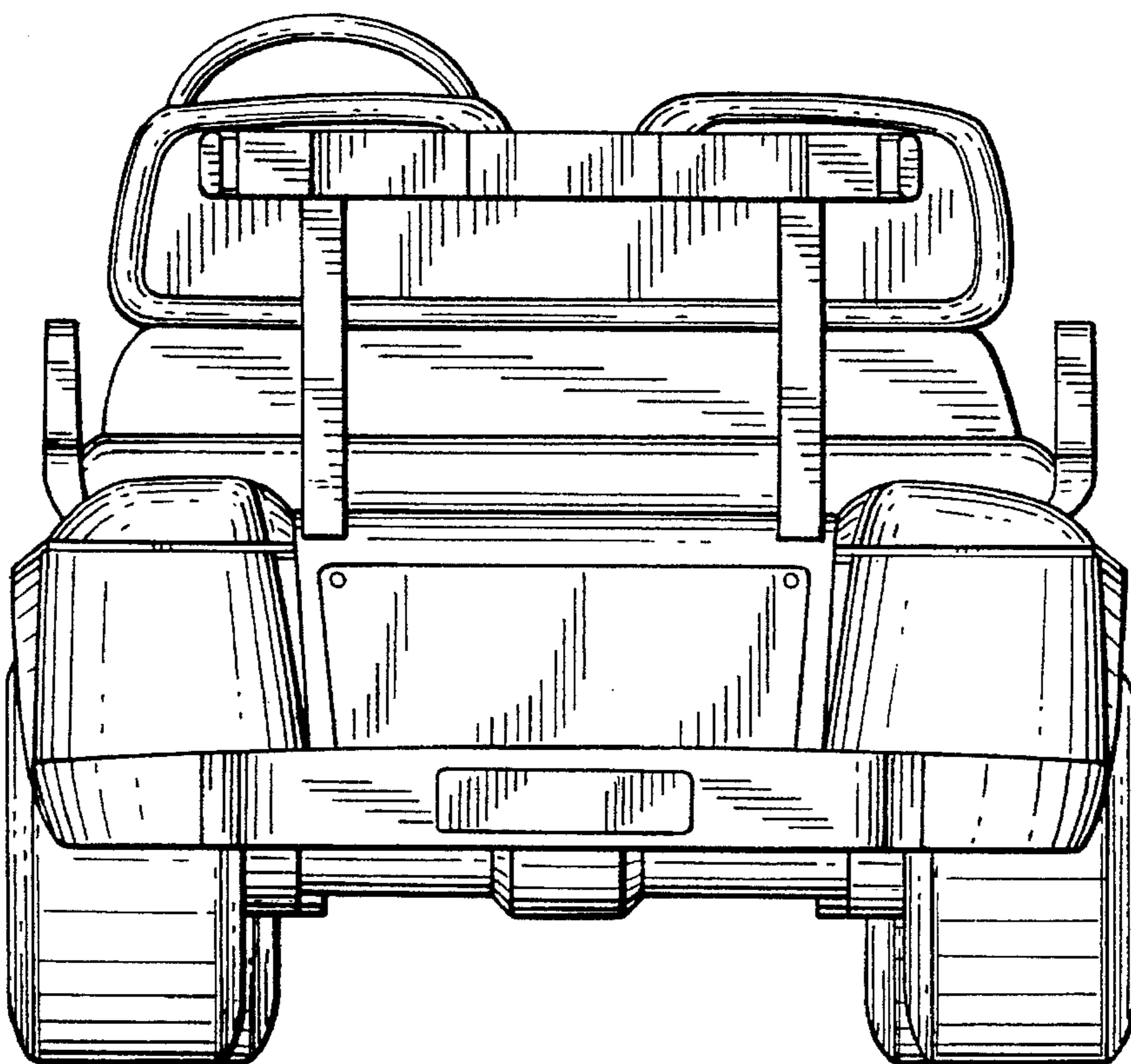

FIG. 5