



US00D369731S

United States Patent [19]

[11] Patent Number: **Des. 369,731**

Rosier

[45] Date of Patent: ****May 14, 1996**

[54] INSTALLATION TOOL FOR SETTING PULL TYPE FASTENERS

[75] Inventor: **Hendrik E. Rosier**, Kingston, N.Y.

[73] Assignee: **Huck International, Inc.**, Irvine, Calif.

[**] Term: **14 Years**

[21] Appl. No.: **16,199**

[22] Filed: **Dec. 10, 1993**

[52] U.S. Cl. **D8/68**

[58] Field of Search D8/61, 69, 68;
72/391.6, 391, 453.17, 453.19; 29/818,
809, 810, 243.523, 243.525

[56] References Cited

U.S. PATENT DOCUMENTS

| | | | |
|------------|---------|-----------------------|------------|
| D. 335,250 | 5/1993 | Rosier . | |
| 4,031,619 | 6/1977 | Gregory . | |
| 4,259,858 | 4/1981 | Freeman et al. | 29/243.523 |
| 4,263,801 | 4/1981 | Gregory . | |
| 4,347,728 | 9/1982 | Smith . | |
| 4,489,471 | 12/1984 | Gregory . | |
| 4,546,637 | 10/1985 | Elias | 29/243.523 |
| 4,580,435 | 4/1986 | Port et al. . | |
| 4,597,263 | 7/1986 | Corbett . | |
| 4,598,572 | 7/1986 | Mondello et al. . | |
| 4,615,206 | 10/1986 | Rosier . | |
| 4,630,460 | 12/1986 | Mauer | 29/243.523 |
| 4,649,732 | 3/1987 | Molina . | |
| 4,735,048 | 4/1988 | Gregory . | |
| 4,770,023 | 9/1988 | Schwab | 29/243.523 |
| 4,807,348 | 2/1989 | Kaelin et al. . | |
| 4,813,261 | 3/1989 | Rosier . | |
| 4,815,310 | 3/1989 | Summerlin et al. | 29/243.523 |
| 4,852,376 | 8/1989 | Suhov . | |
| 4,866,972 | 9/1989 | Schwab | 29/243.523 |
| 4,878,372 | 11/1989 | Port et al. . | |
| 4,989,442 | 2/1991 | Rosier . | |
| 5,036,572 | 8/1991 | Rosier . | |
| 5,123,162 | 6/1992 | Wing et al. . | |
| 5,146,773 | 9/1992 | Rosier . | |
| 5,208,958 | 5/1993 | Wilcox . | |
| 5,208,959 | 5/1993 | Rosier et al. . | |
| 5,228,610 | 7/1993 | Spence . | |

OTHER PUBLICATIONS

Instruction Manual Models 586; 586NS; 586-2 Hydraulic Installation Tools, Huck International, Inc. Jan. 1994.

Instruction Manual Model 585 Hydraulic Installation Tool, Huck International, Inc. May 1993.

Primary Examiner—Alan P. Douglas

Attorney, Agent, or Firm—Harness, Dickey & Pierce

[57] CLAIM

The ornamental design for installation tool for setting pull type fasteners, as shown and described.

DESCRIPTION

FIG. 1 is a perspective view of the installation tool with a nose assembly shown in phantom at the front end of the tool; FIG. 2 is front elevational view of the installation tool of FIG. 1;

FIG. 3 is a side elevational view of the installation tool of FIG. 1;

FIG. 4 is a rear elevational view of the installation tool of FIG. 1;

FIG. 5 is a top elevation view of the installation tool of FIG. 1 with the nose assembly shown rotated around 90° from that shown in FIGS. 1 and 3;

FIG. 6 is a bottom elevational view of the installation tool of FIG. 1 with the nose assembly shown rotated around 90° from that shown in FIGS. 1 and 3;

FIG. 7 is a perspective view of a second embodiment of FIGS. 1-6 with the nose assembly, which was shown in phantom, being shown in solid lines in the position depicted in FIGS. 1 and 3;

FIG. 8 is a top elevational view of the installation tool of FIG. 7 with the nose assembly shown in the position depicted in phantom in FIG. 5;

FIG. 9 is a bottom elevational view of the installation tool of FIG. 7 with the nose assembly shown in the position depicted in phantom in FIG. 6;

FIG. 10 is a front elevational view of the installation tool of FIG. 7;

FIG. 11 is a side elevational view of the installation tool of FIG. 7; and,

FIG. 12 is a rear elevational view of the installation tool of FIG. 7.

1 Claim, 5 Drawing Sheets

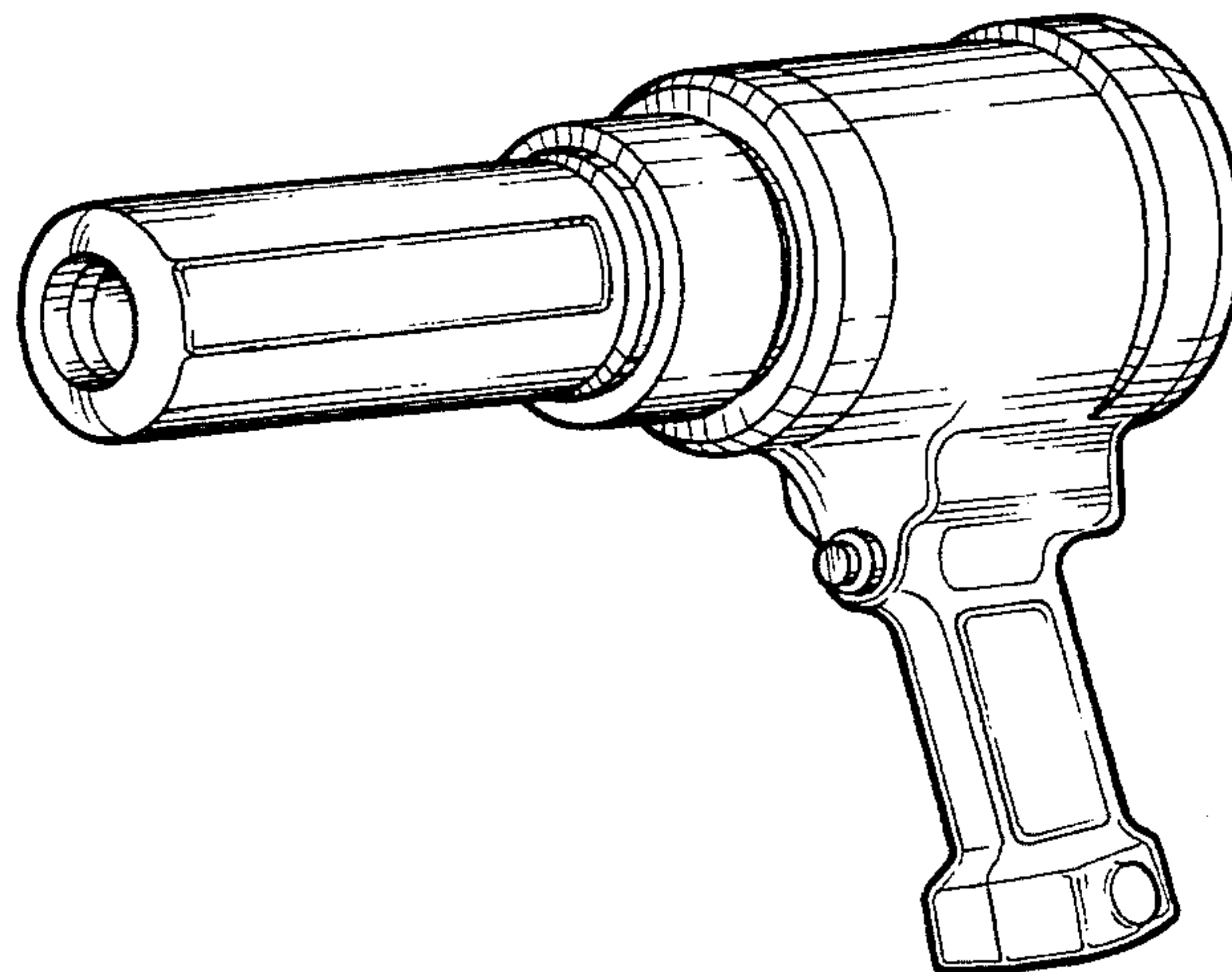

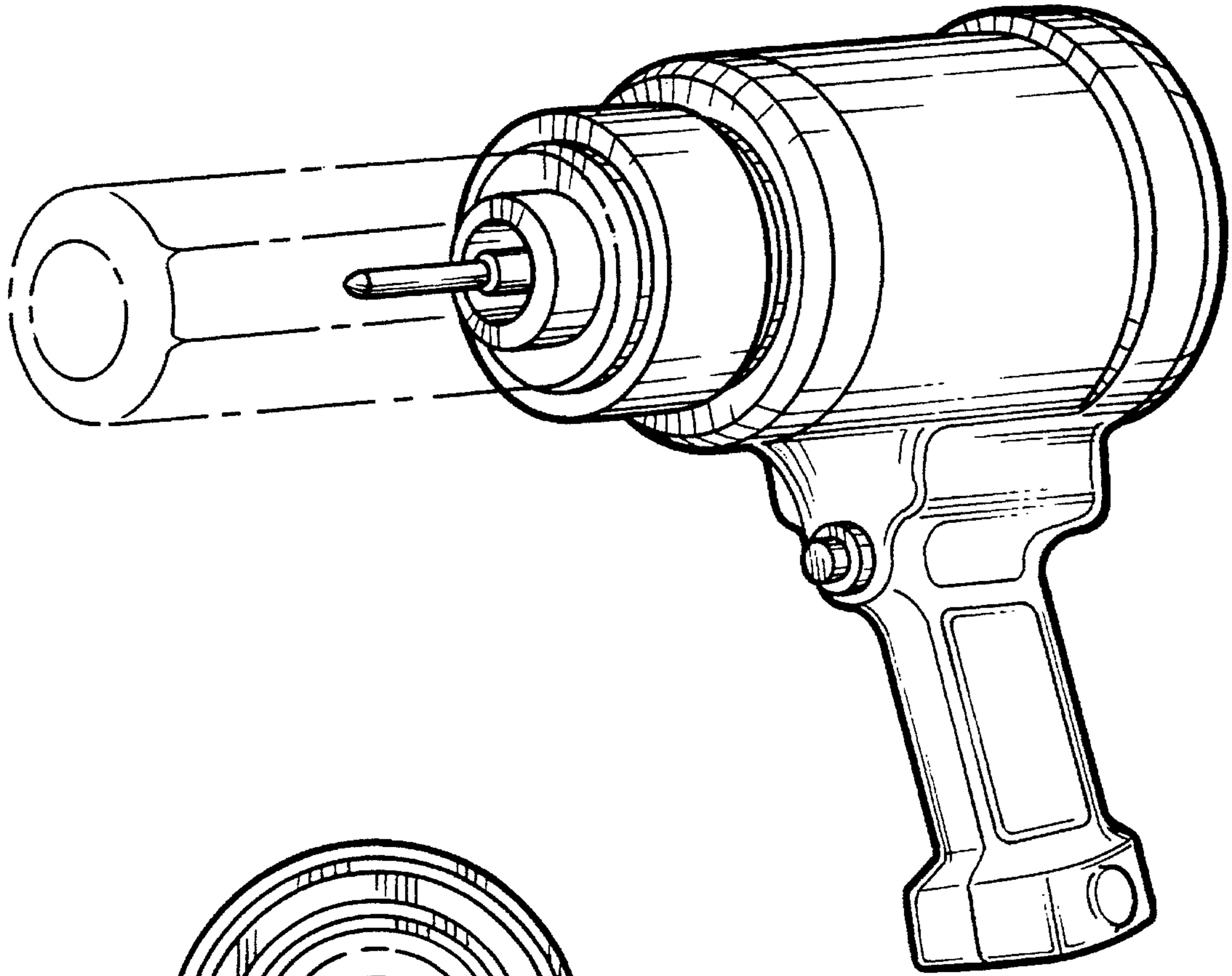

Fig-1

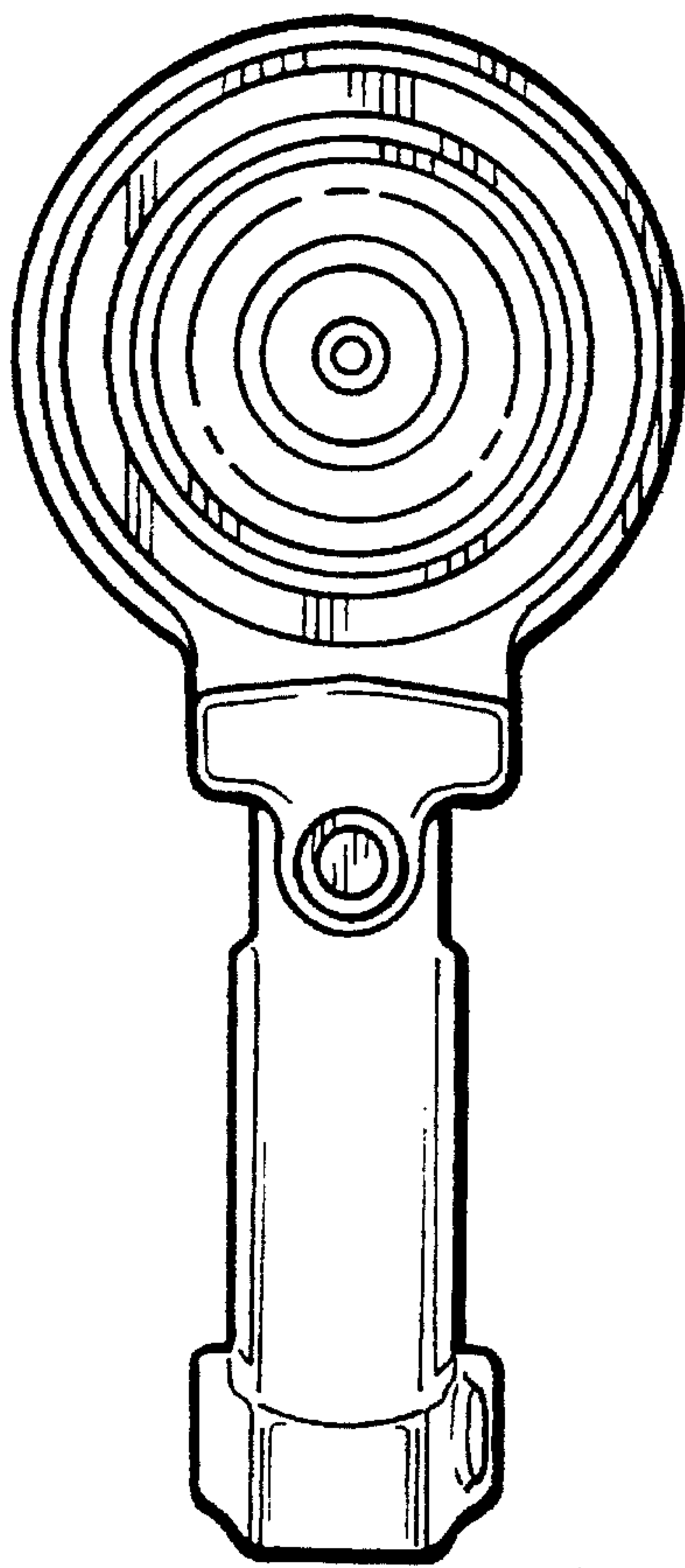

Fig-2

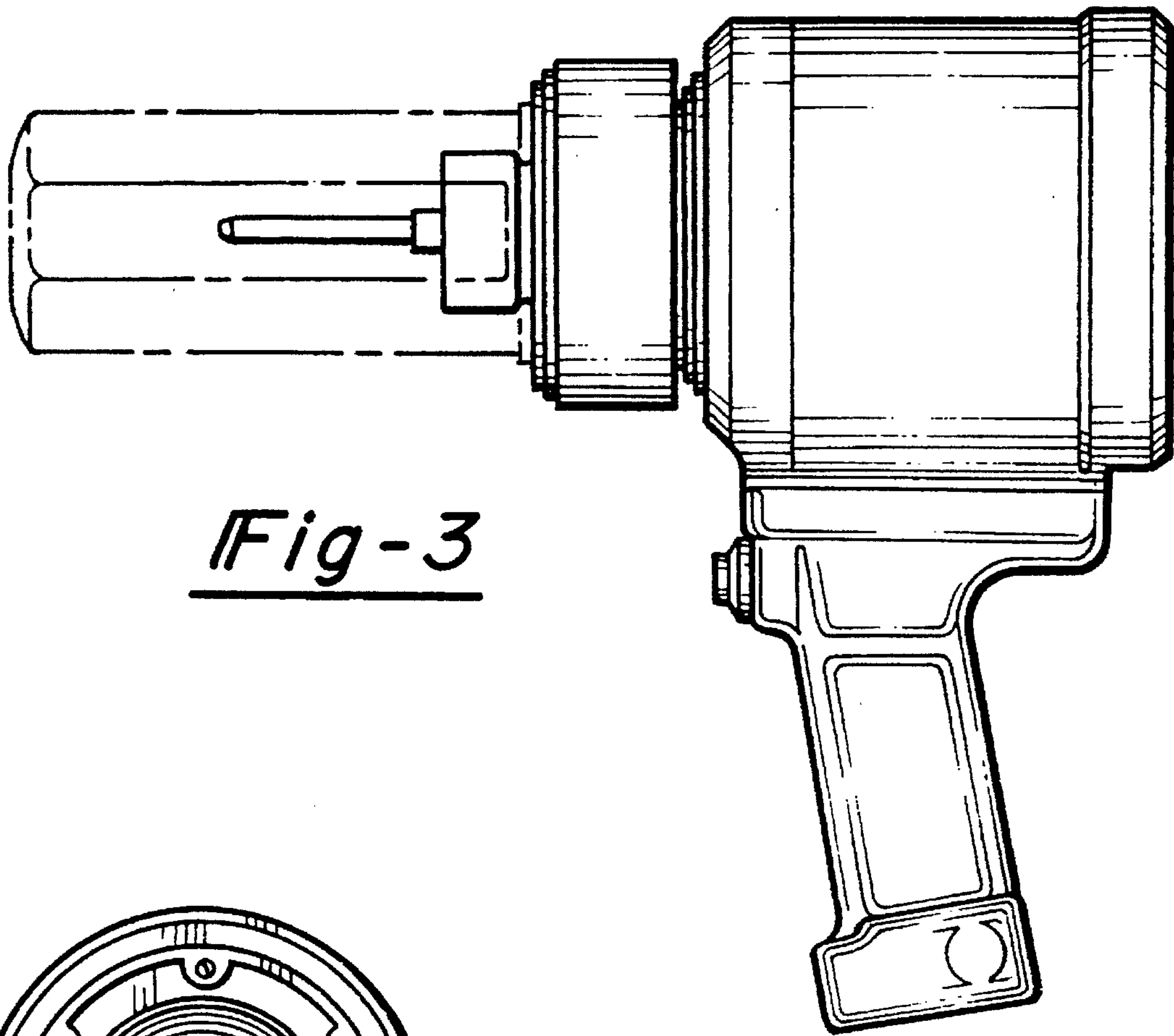

Fig-3

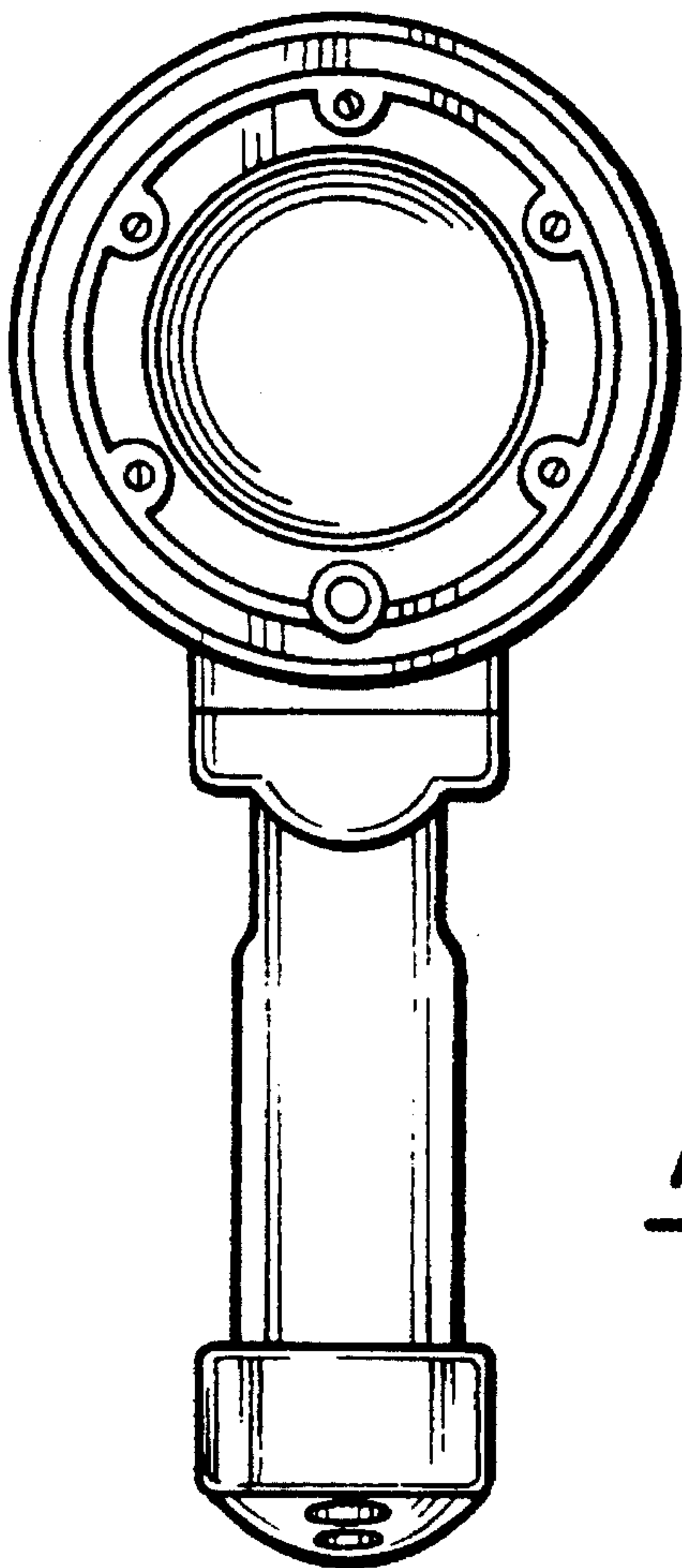

Fig-4

Fig-5

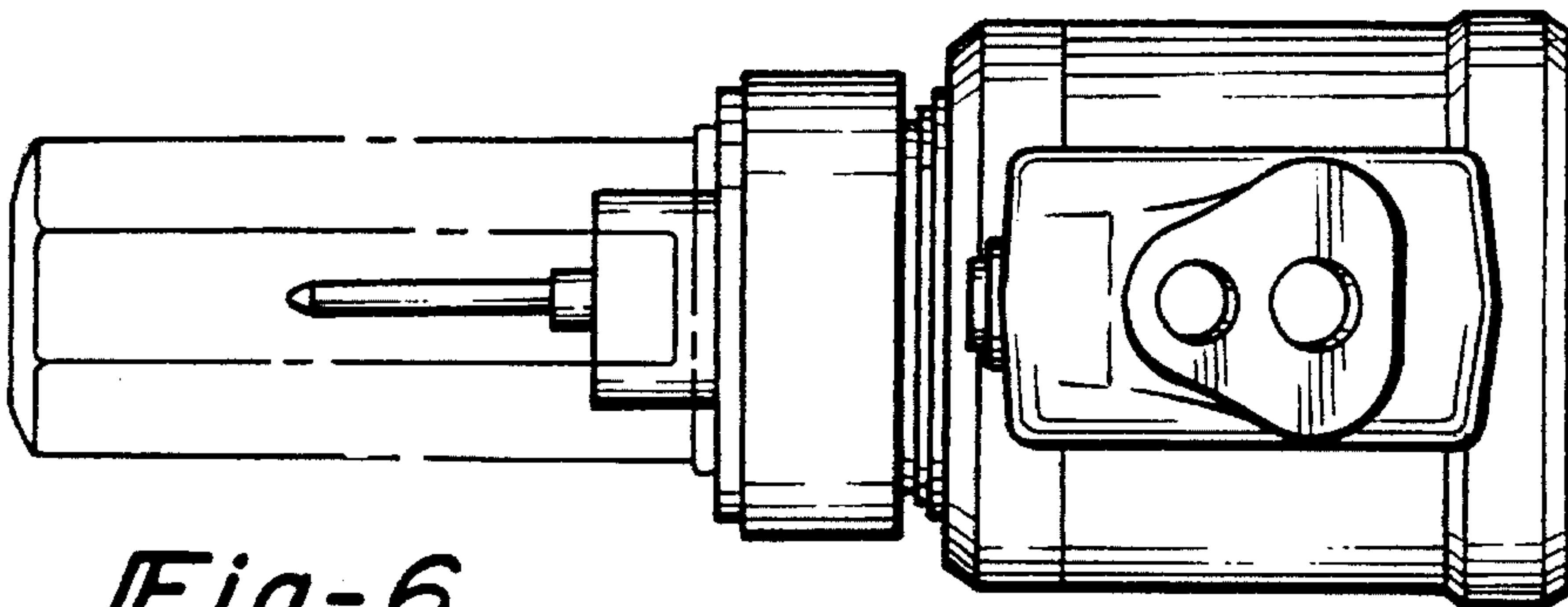
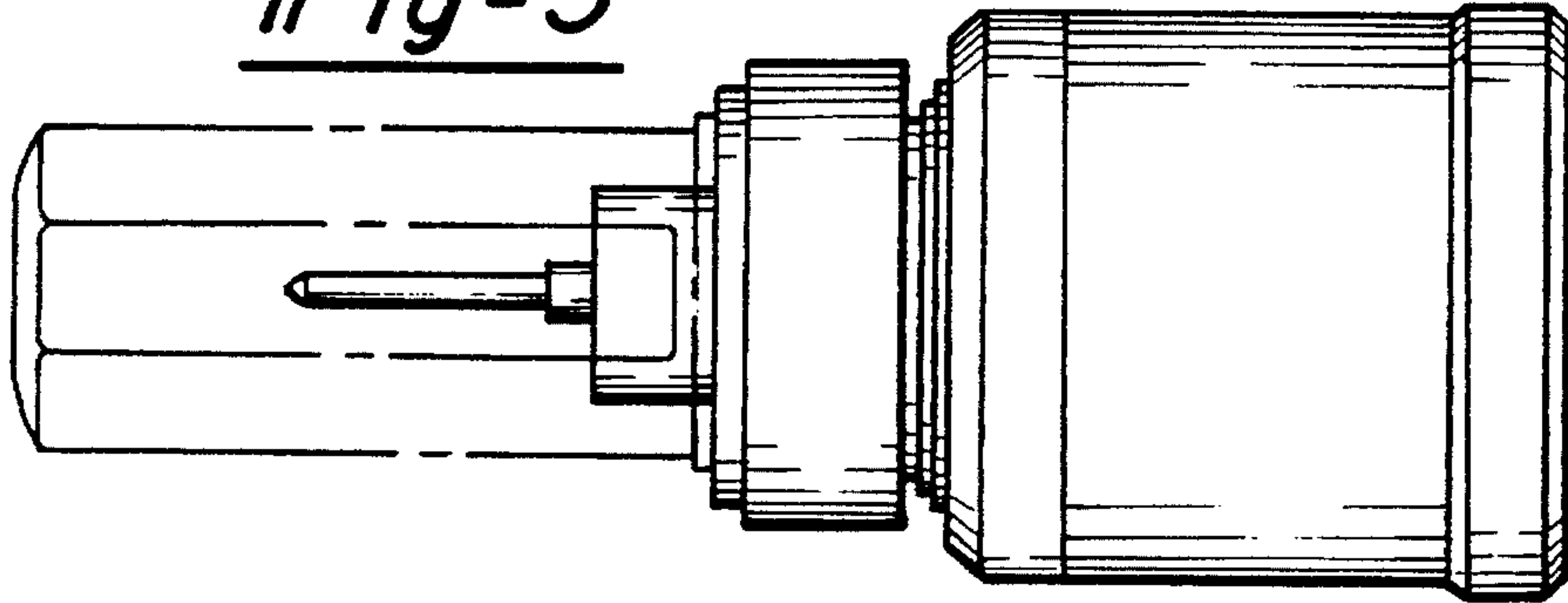

Fig-6

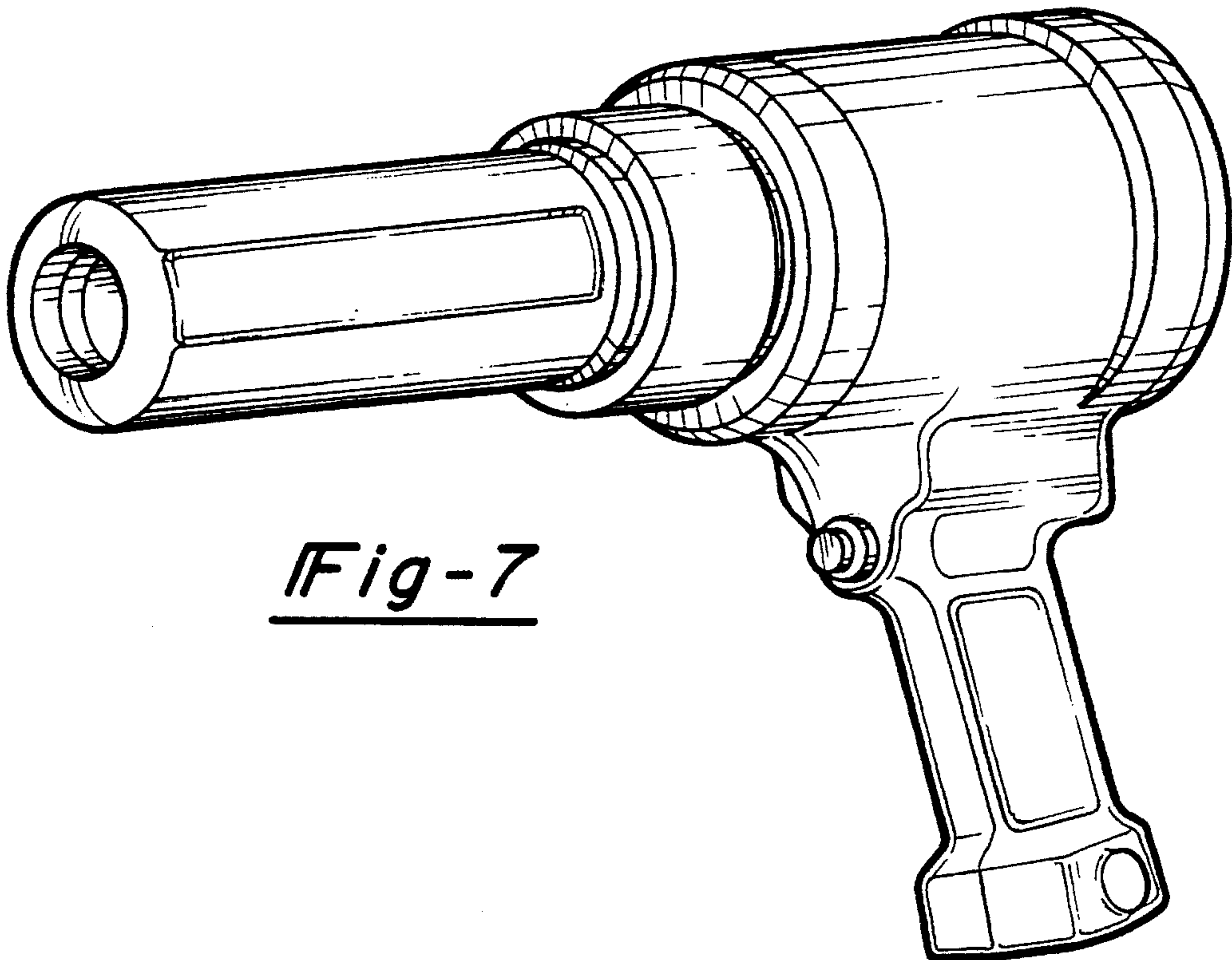

Fig-7

Fig-8

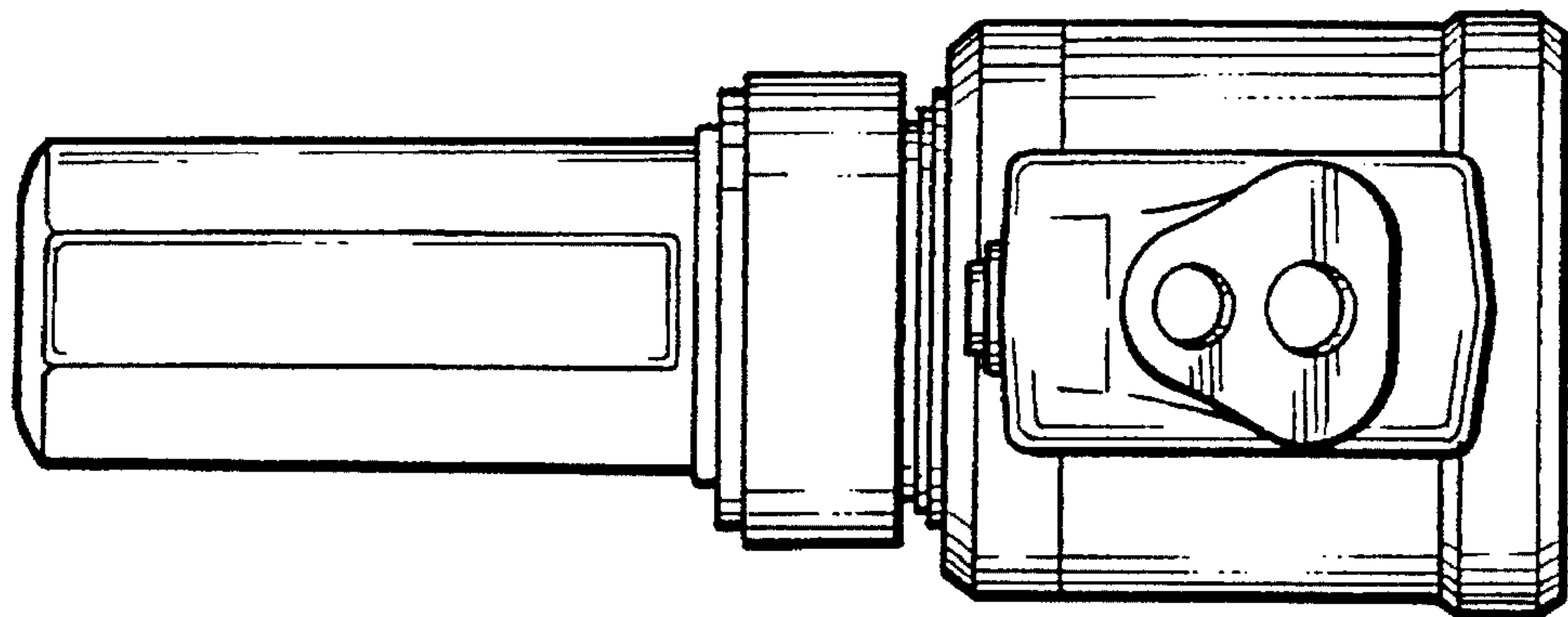
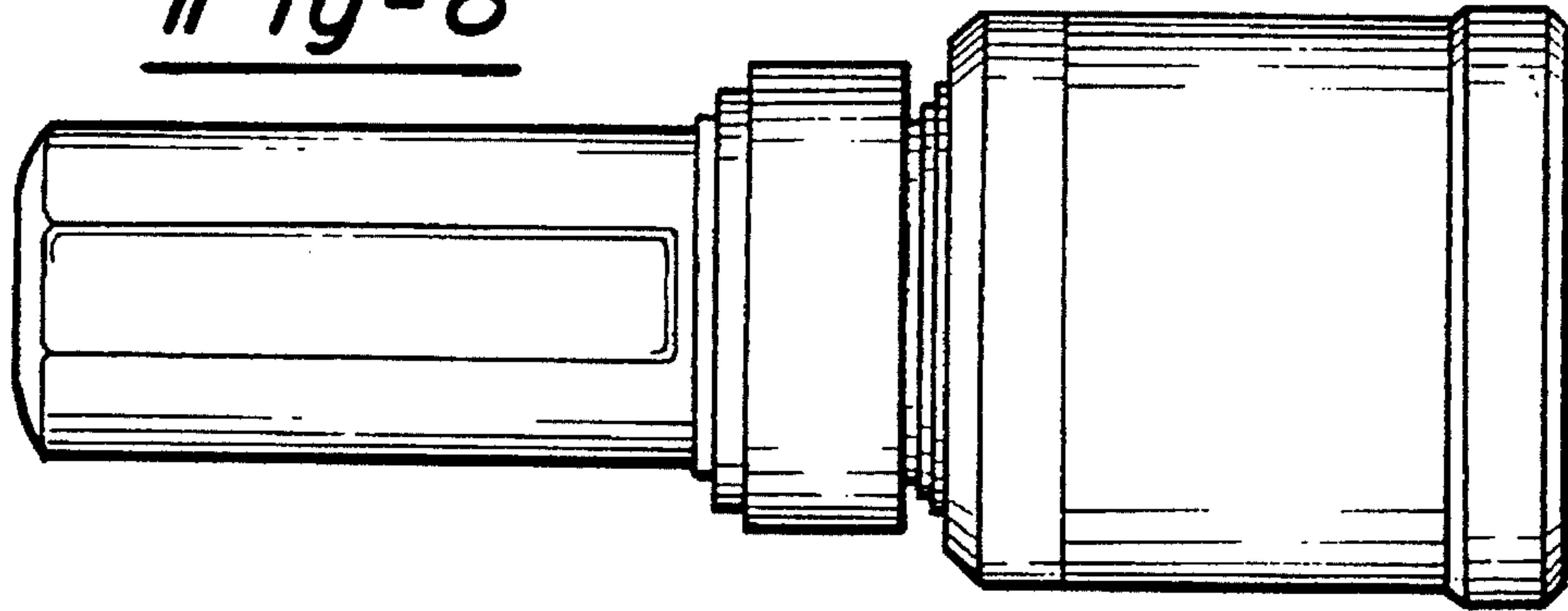

Fig-9

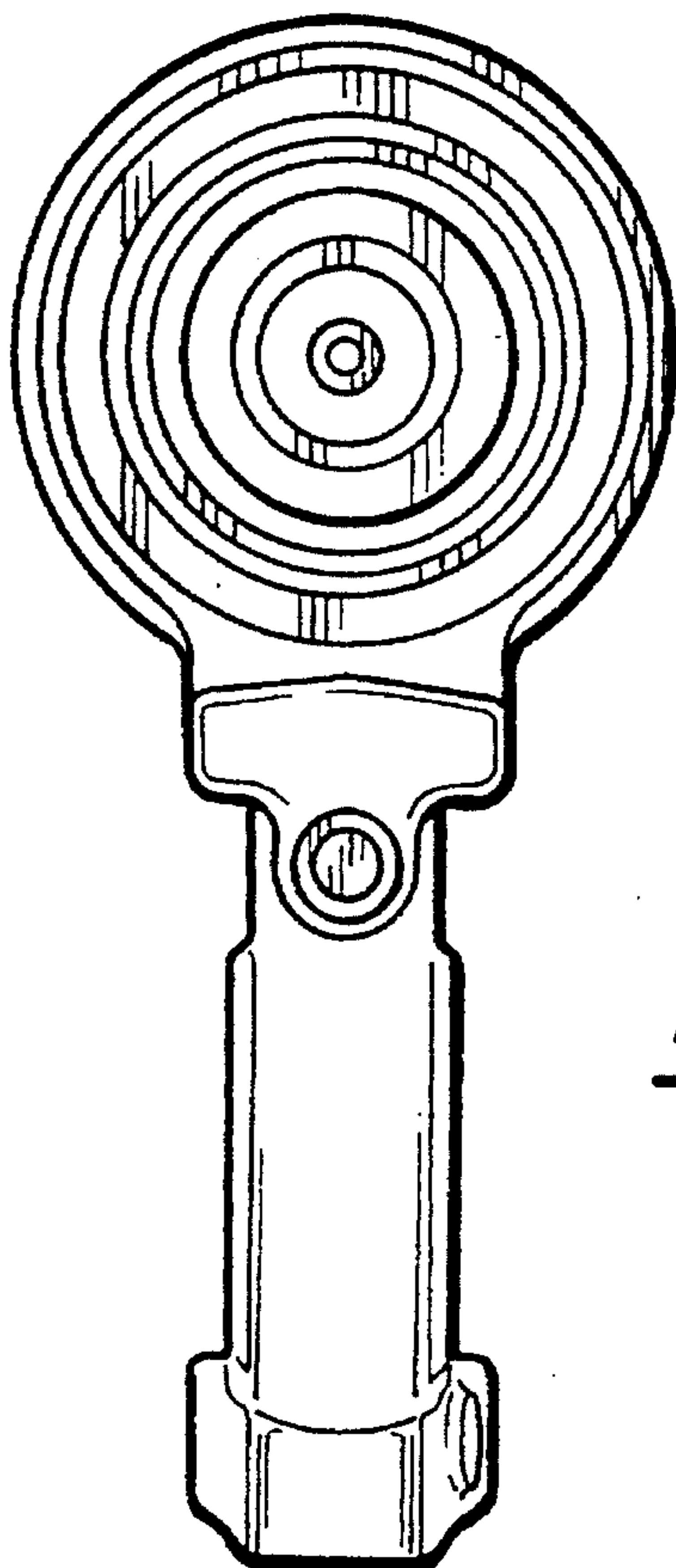

Fig-10

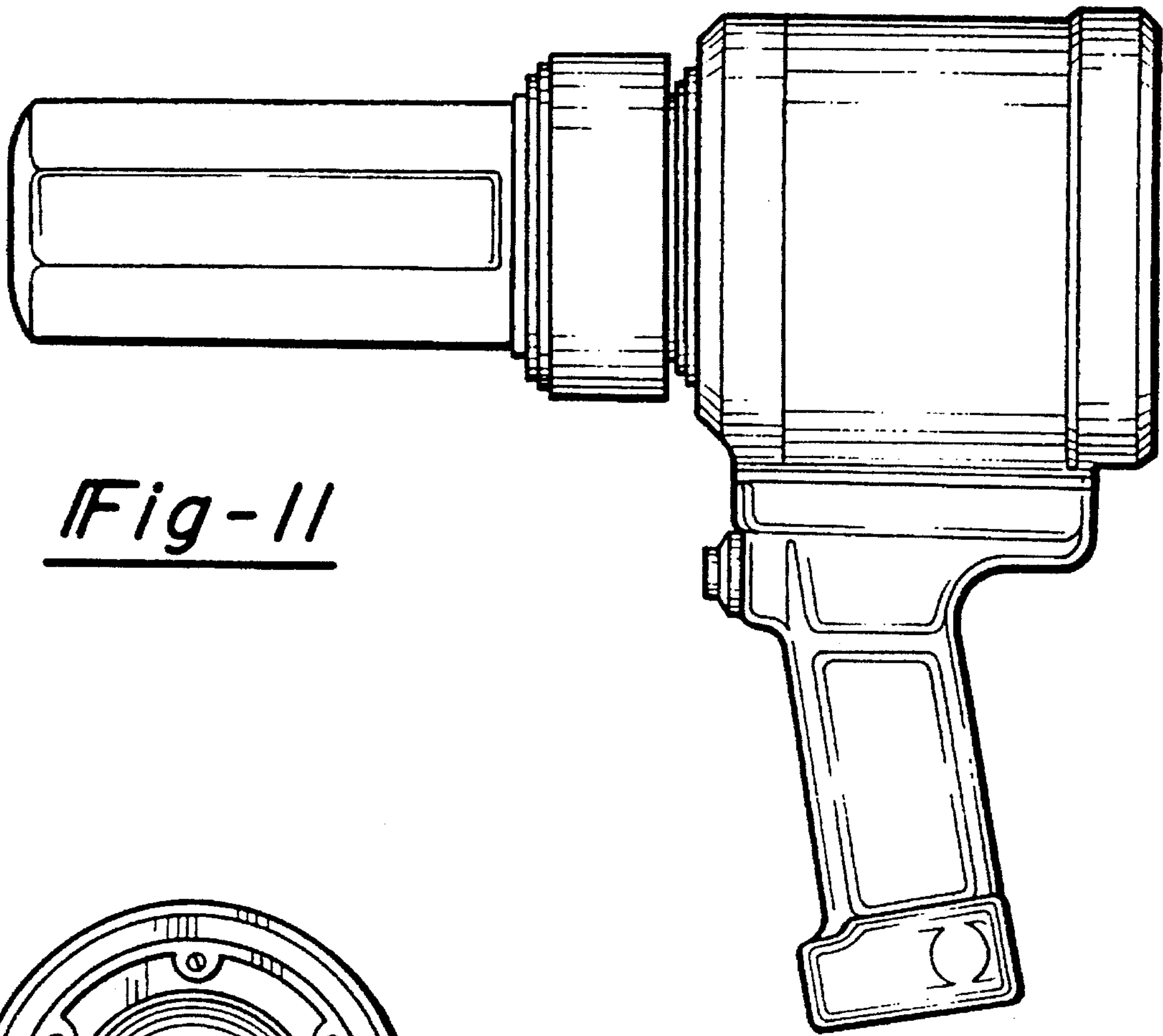

Fig-11

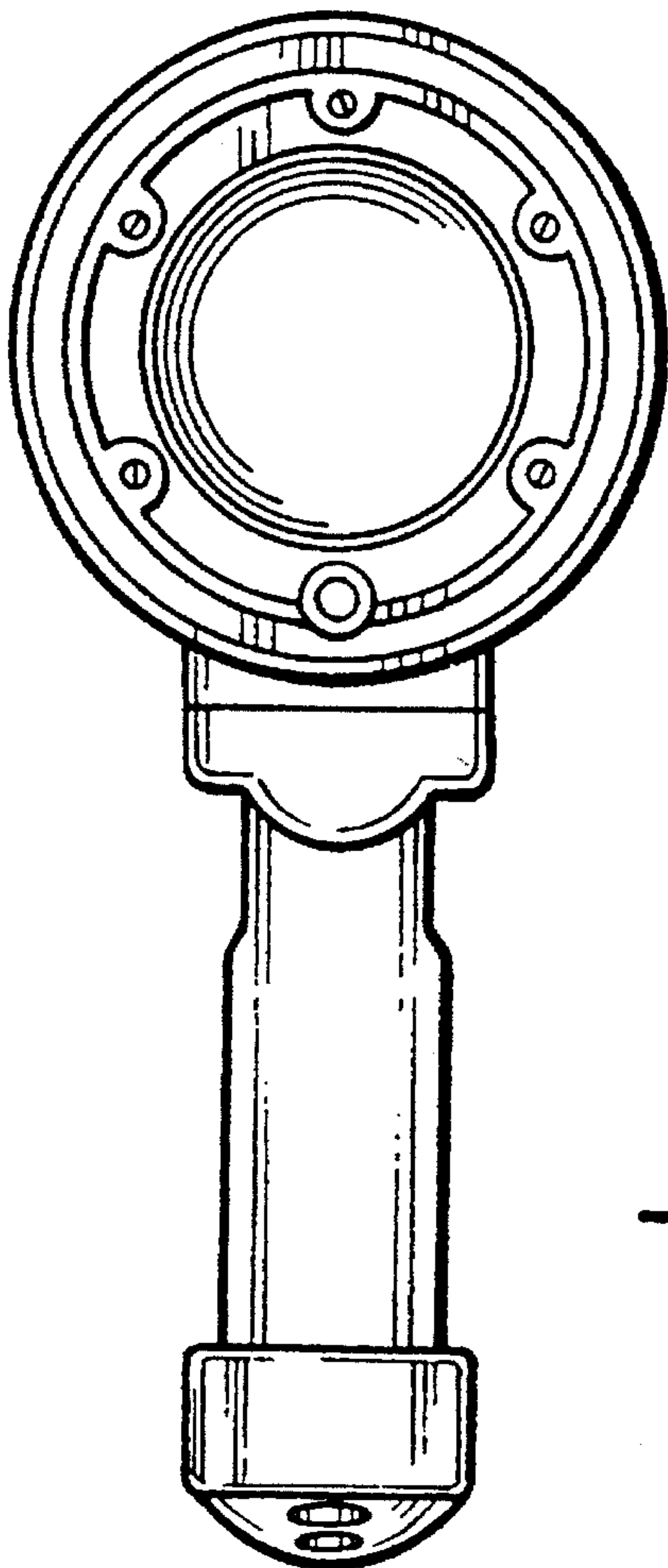

Fig-12