



US00D369474S

United States Patent [19]

[11] Patent Number: **Des. 369,474**

Slichter et al.

[45] Date of Patent: ****May 7, 1996**

[54] **DOUBLE CAR SEAT**

[76] Inventors: **Allan Slichter**, P.O. Box 47, Riggins, Id. 83549; **Todd Slichter**, P.O. Box 745, Lakefork, Id. 83635

[**] Term: **14 Years**

[21] Appl. No.: **28,005**

[22] Filed: **Sep. 2, 1994**

[52] U.S. Cl. **D6/333**

[58] Field of Search D6/333, 329; D12/129; 297/248, 250.1, 256.15, 256.17, 464, 467, 485, 487, 488; 5/655

[56] **References Cited**

U.S. PATENT DOCUMENTS

D. 208,464	9/1967	Walker et al.	D6/333
D. 235,492	6/1975	Armstrong et al.	D6/333
D. 353,947	1/1995	Gain	D6/333
4,033,622	7/1977	Boudreau	D6/333
4,580,842	4/1986	Segal	D6/333

4,722,568	2/1988	Irvin .
5,054,853	10/1991	Gillies et al. .
5,205,308	4/1993	Kendall et al. .
5,213,393	5/1993	Maurer et al. .
5,228,746	7/1993	Burleigh .

Primary Examiner—Janice E. Seeger

[57] **CLAIM**

The ornamental design for the double car seat, as shown and described.

DESCRIPTION

FIG. 1 is a front elevational view of the double car seat showing our new design;
 FIG. 2 is a rear elevational view thereof;
 FIG. 3 is a left side elevational view thereof;
 FIG. 4 is a right side elevational view thereof;
 FIG. 5 is a top plan view thereof;
 FIG. 6 is a bottom plan view thereof; and,
 FIG. 7 is a perspective view thereof.

1 Claim, 4 Drawing Sheets

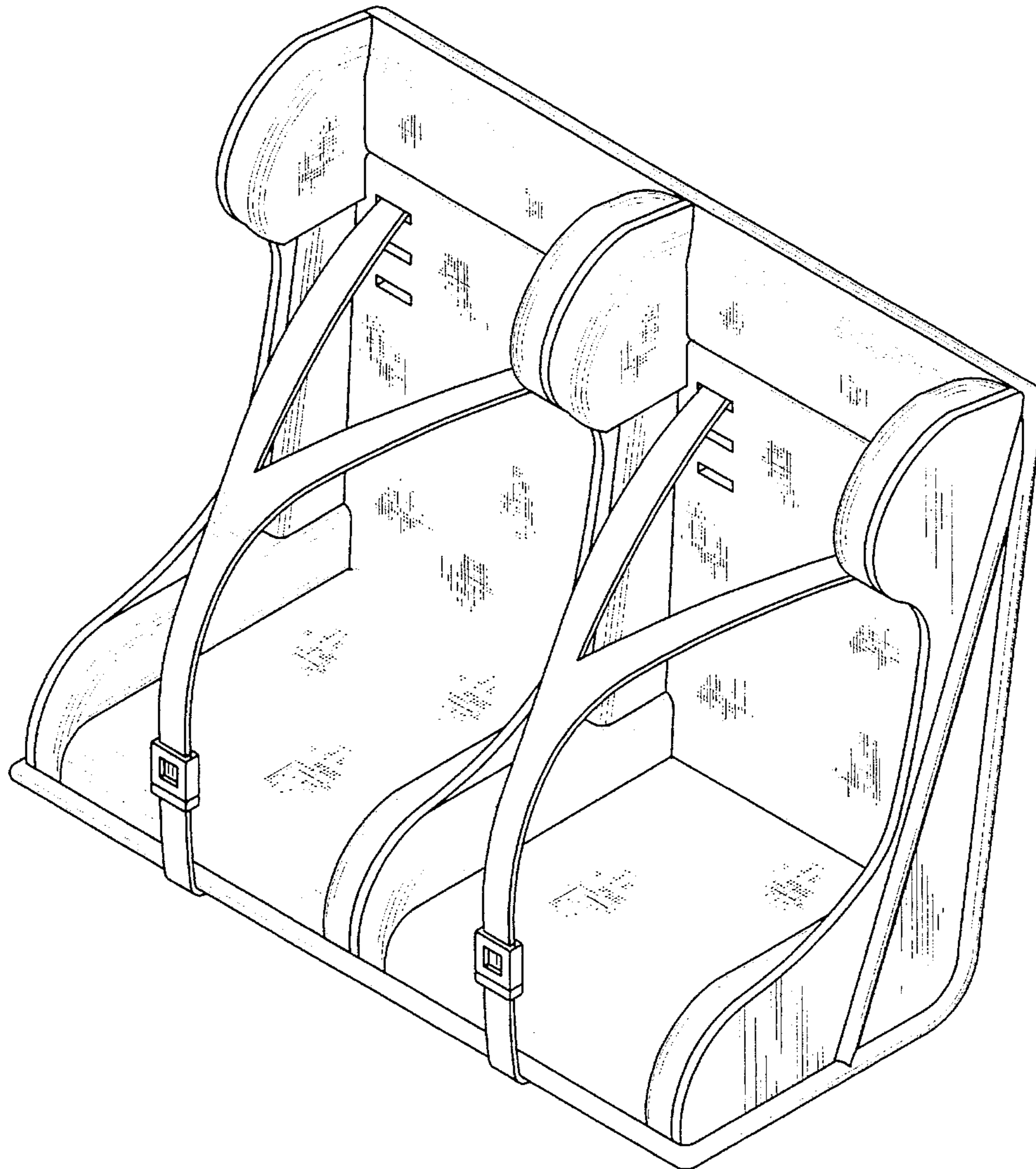

FIG. 1

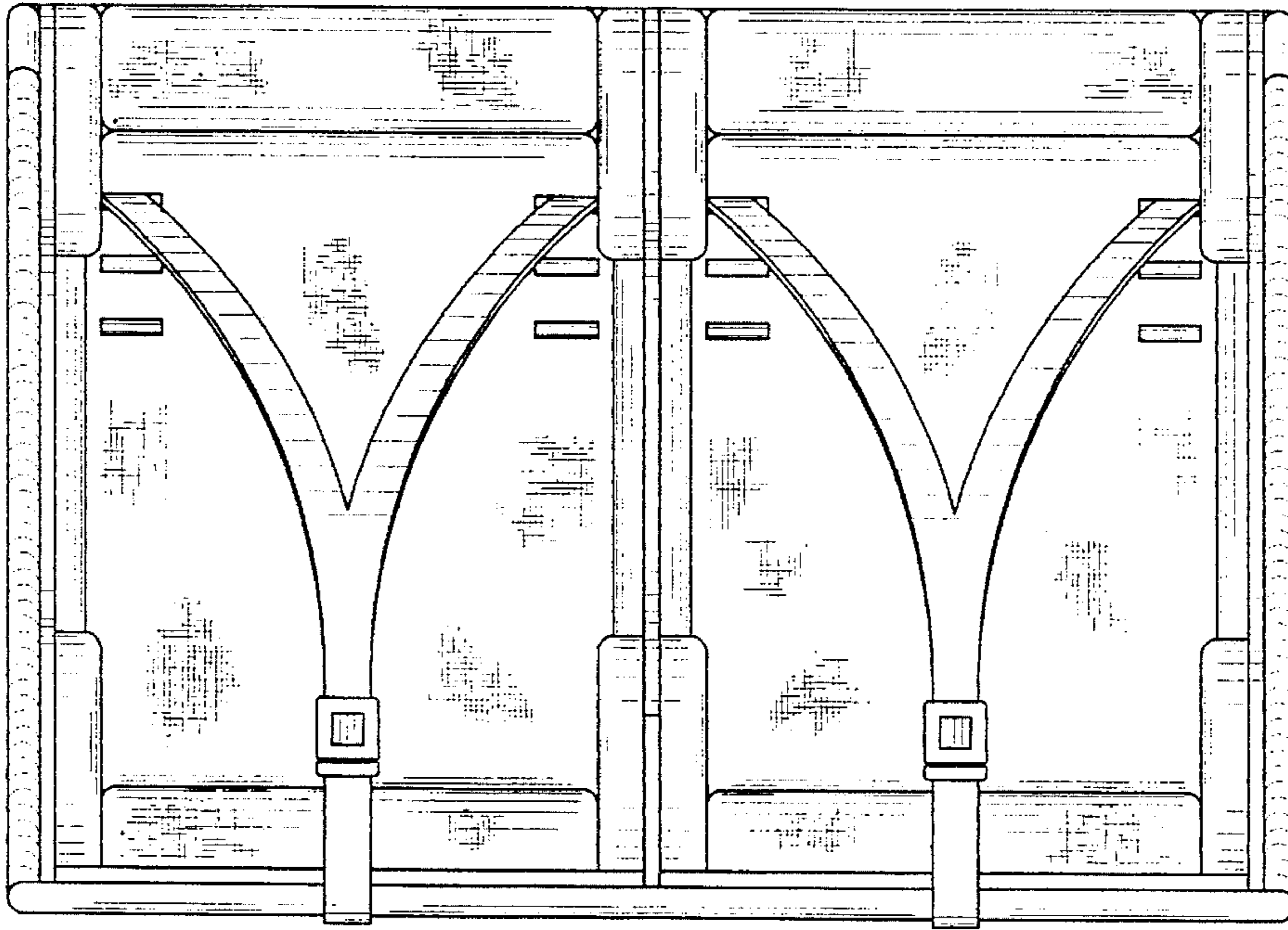

FIG. 2

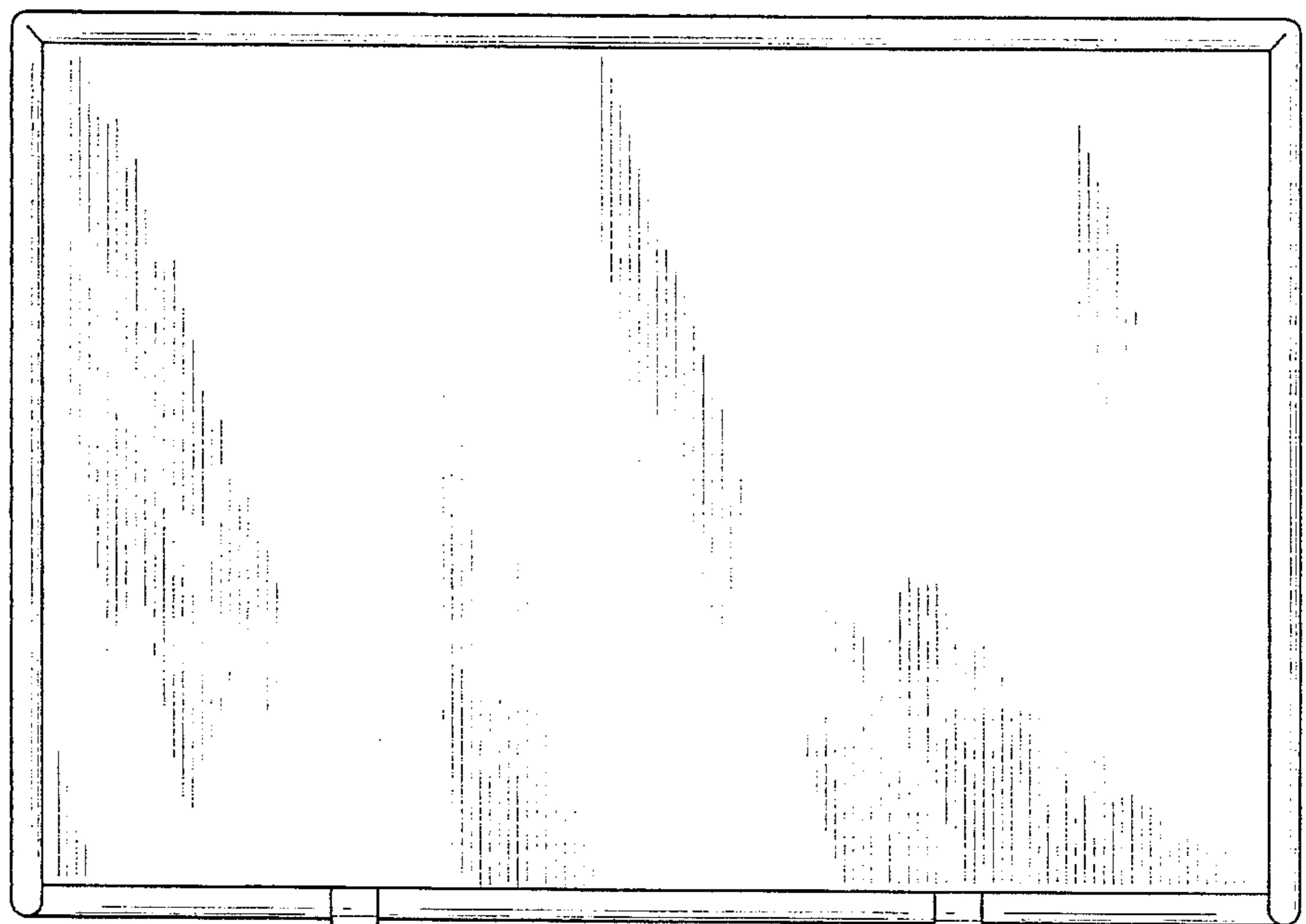

FIG. 3

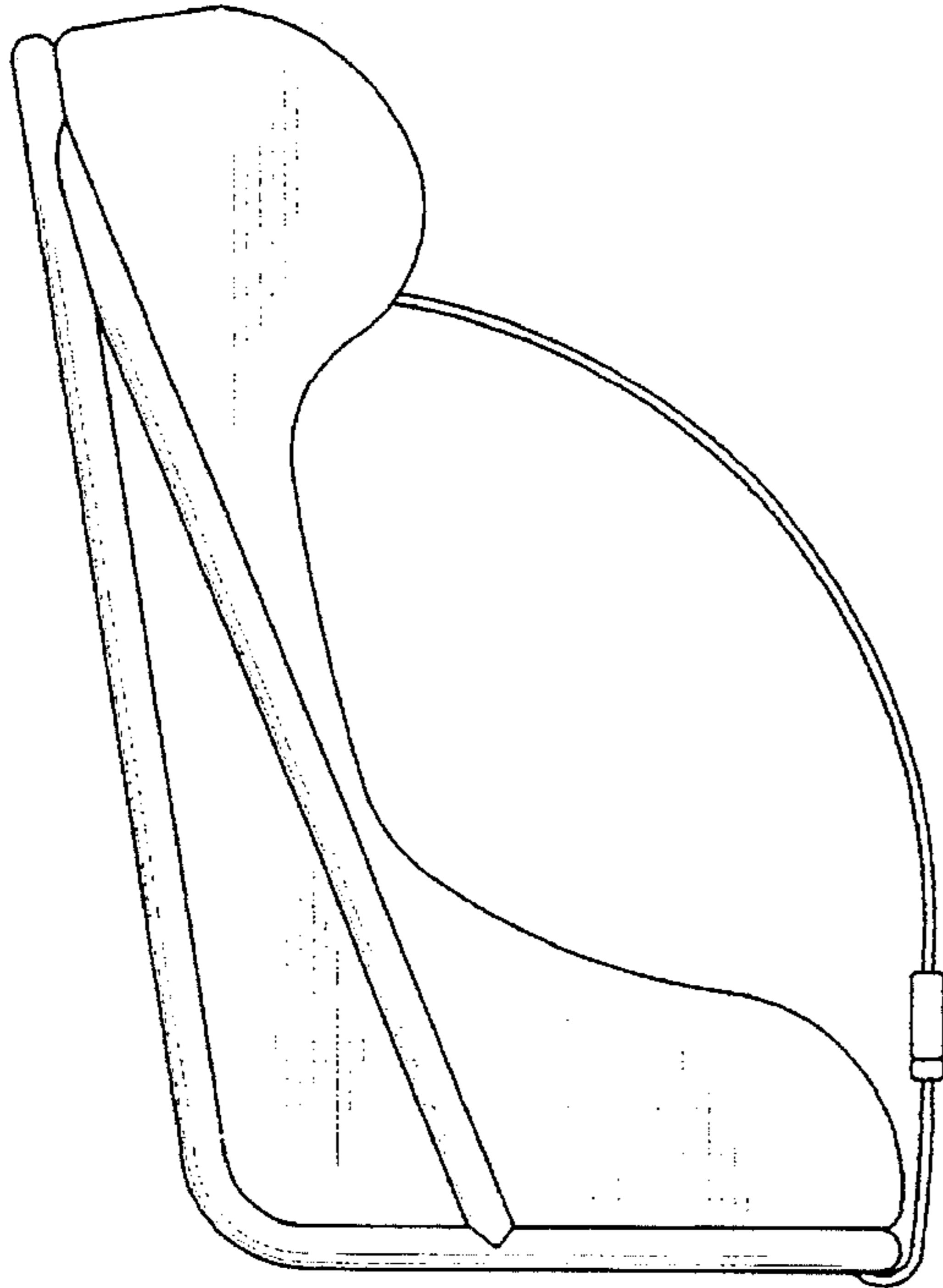

FIG. 4

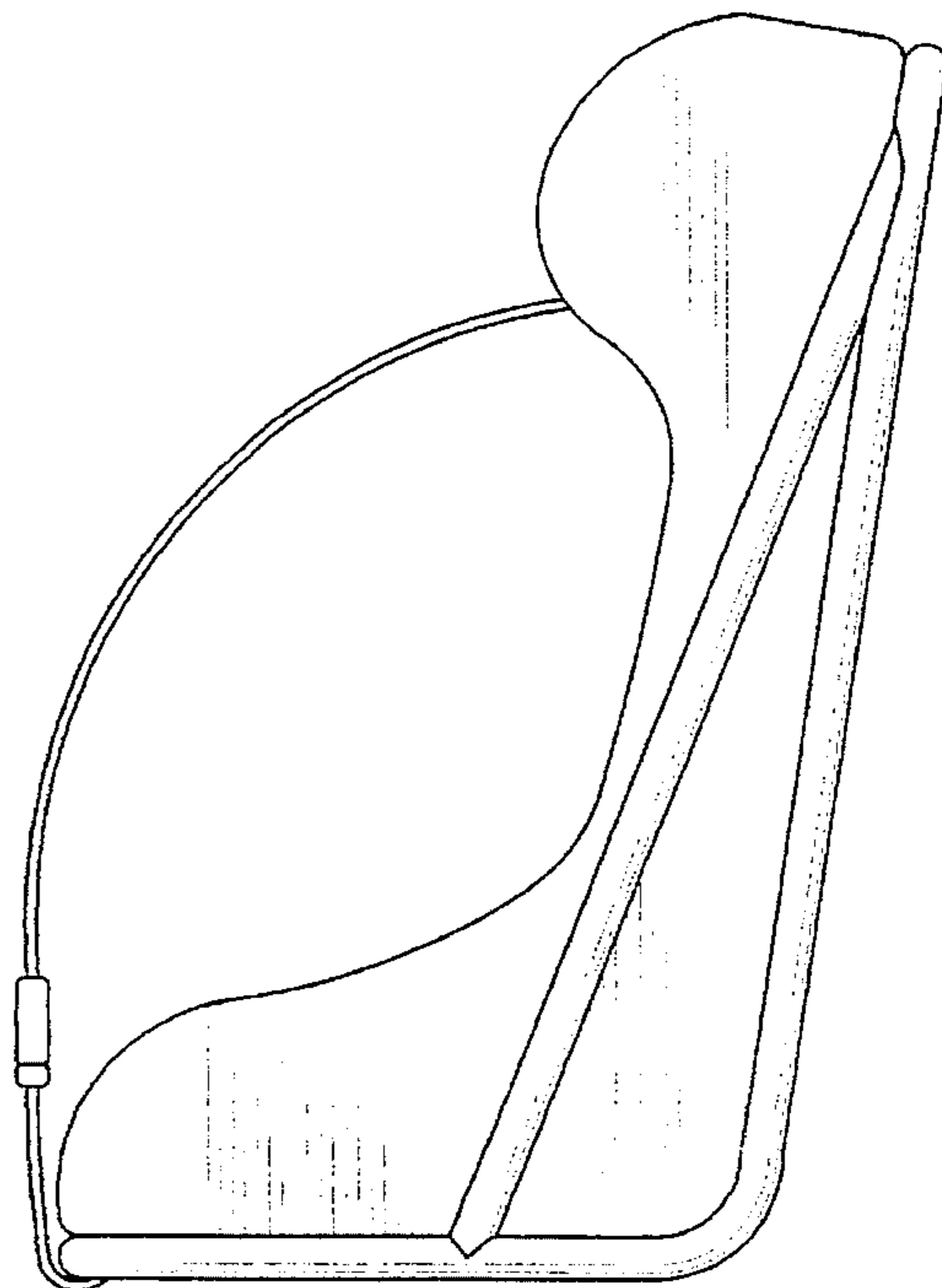

FIG. 5

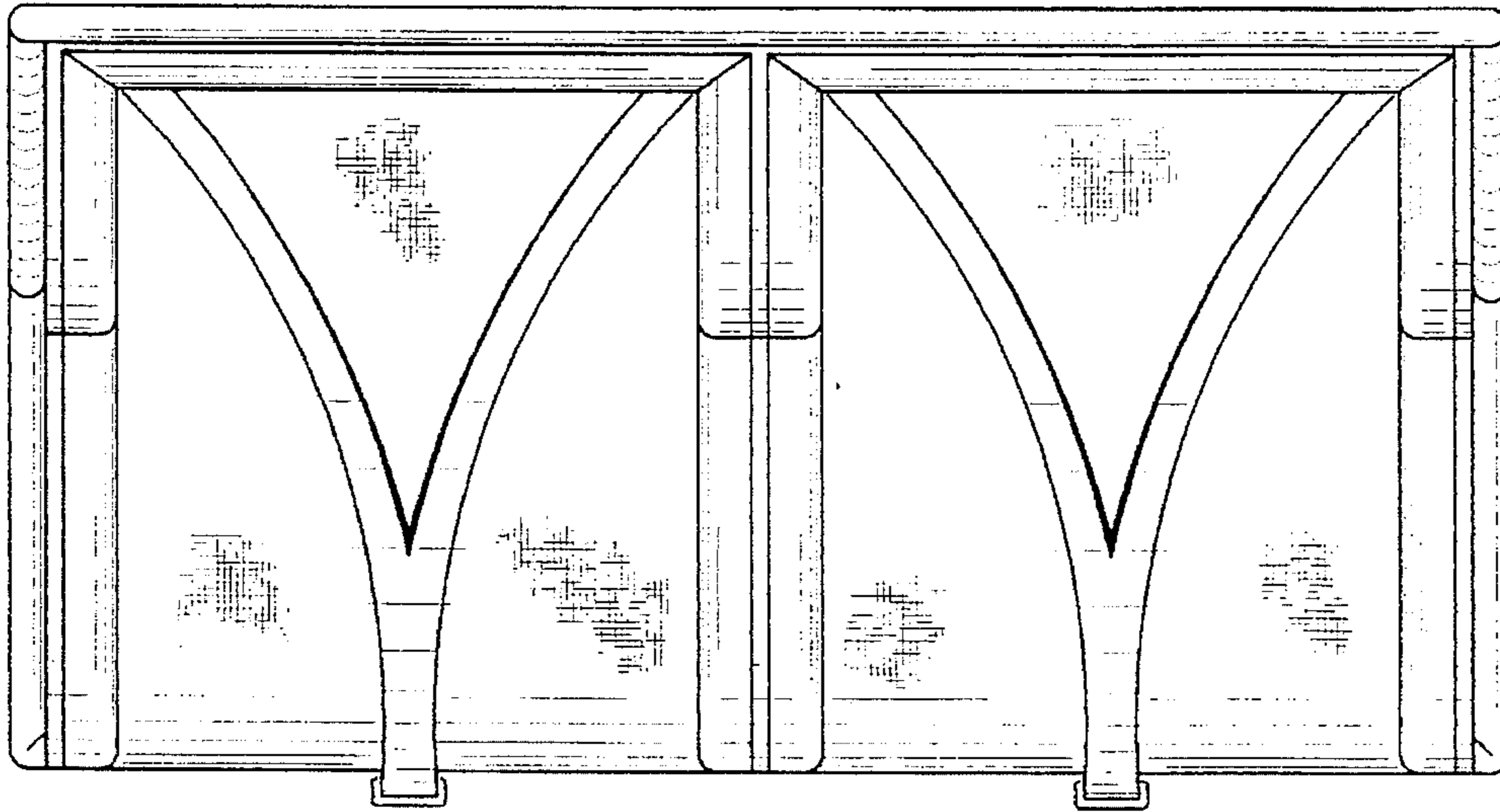

FIG. 6

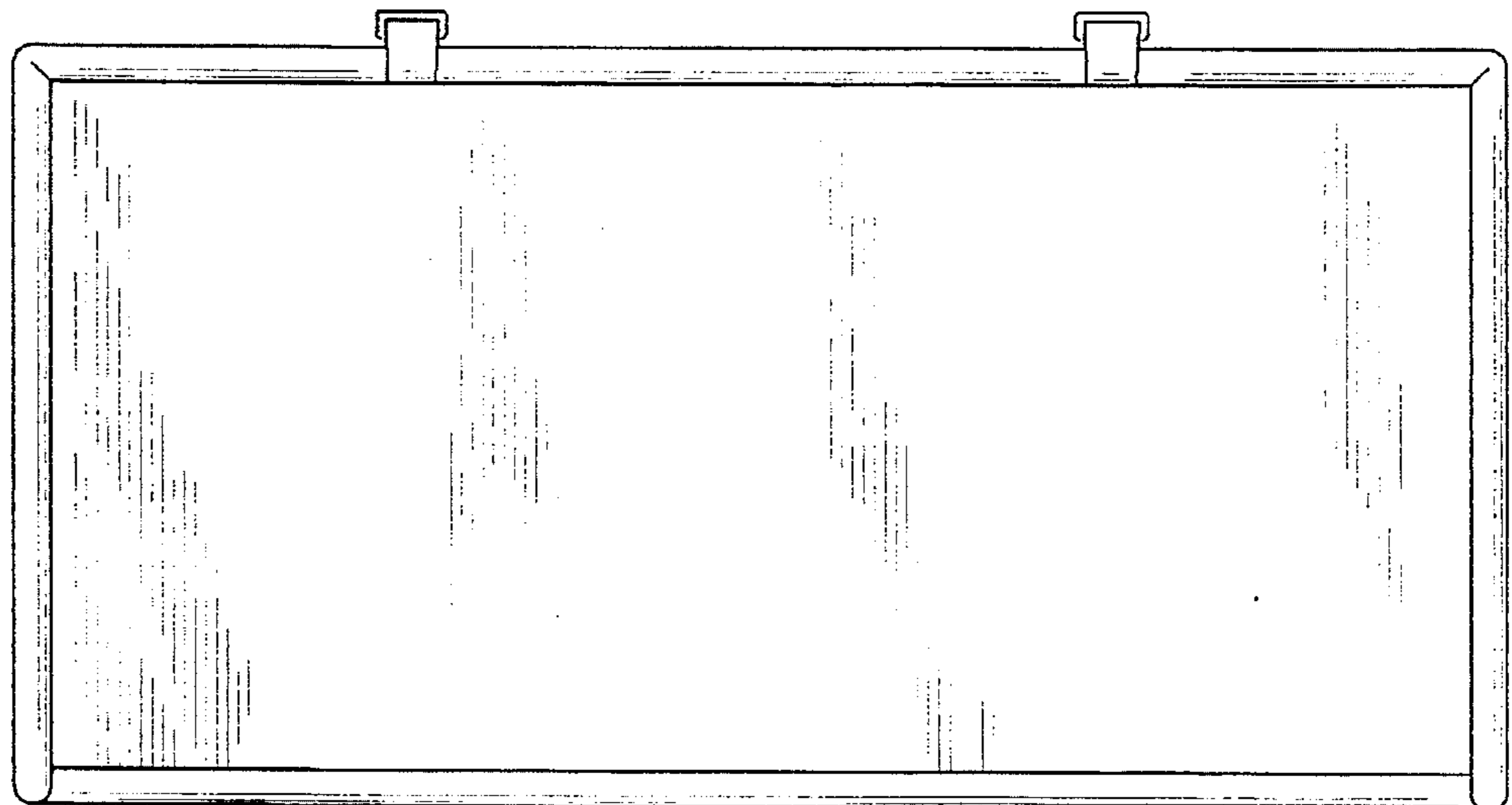

FIG. 7

