



US00D369137S

United States Patent [19]

[11] Patent Number: **Des. 369,137**

Maruyama et al.

[45] Date of Patent: ****Apr. 23, 1996**

[54] HULL FOR A MOTORBOAT

FOREIGN PATENT DOCUMENTS

[75] Inventors: **Haruyoshi Maruyama**, Kakogawa;
Shin Ogata, Kobe; **Yoshinori Tsumiyama**, Miki, all of Japan

62-34897 2/1987 Japan .

Primary Examiner—Kay H. Chin
Attorney, Agent, or Firm—Marshall, O'Toole, Gerstein,
Murray & Borun

[73] Assignee: **Kawasaki Jukogyo Kabushiki Kaisha**,
Kobe, Japan

[57] CLAIM

[**] Term: **14 Years**

The ornamental design for a hull for motorboat, as shown
and described.

[21] Appl. No.: **36,915**

DESCRIPTION

[22] Filed: **Mar. 30, 1995**

[30] Foreign Application Priority Data

Oct. 3, 1994 [JP] Japan 6-30192

[52] U.S. Cl. **D12/310**; D12/311; D12/314

[58] Field of Search D12/300, 310-315;
114/61, 56, 355, 357, 283, 289, 290, 288,
291

FIG. 1 is a front elevational view of a hull for a motorboat
embodying our novel design;

FIG. 2 is a rear elevational view thereof;

FIG. 3 is a plan view thereof;

FIG. 4 is a bottom view thereof;

FIG. 5 is a right side elevational view, the left side being a
mirror image thereof;

FIG. 6 is a perspective view taken from the top, front and left
side thereof;

FIG. 7 is a perspective view taken from the bottom and right
side thereof;

FIG. 8 is a perspective view taken from the top, rear and
right side thereof; and,

FIG. 9 is a perspective view taken from the bottom, rear and
left side thereof.

[56] References Cited

U.S. PATENT DOCUMENTS

D. 307,574	5/1990	Pipkorn	D12/314
3,259,092	7/1966	Kara, Jr.	114/290
4,672,905	6/1987	Pipkorn	114/290
4,977,845	12/1990	Rundquist	114/288

1 Claim, 8 Drawing Sheets

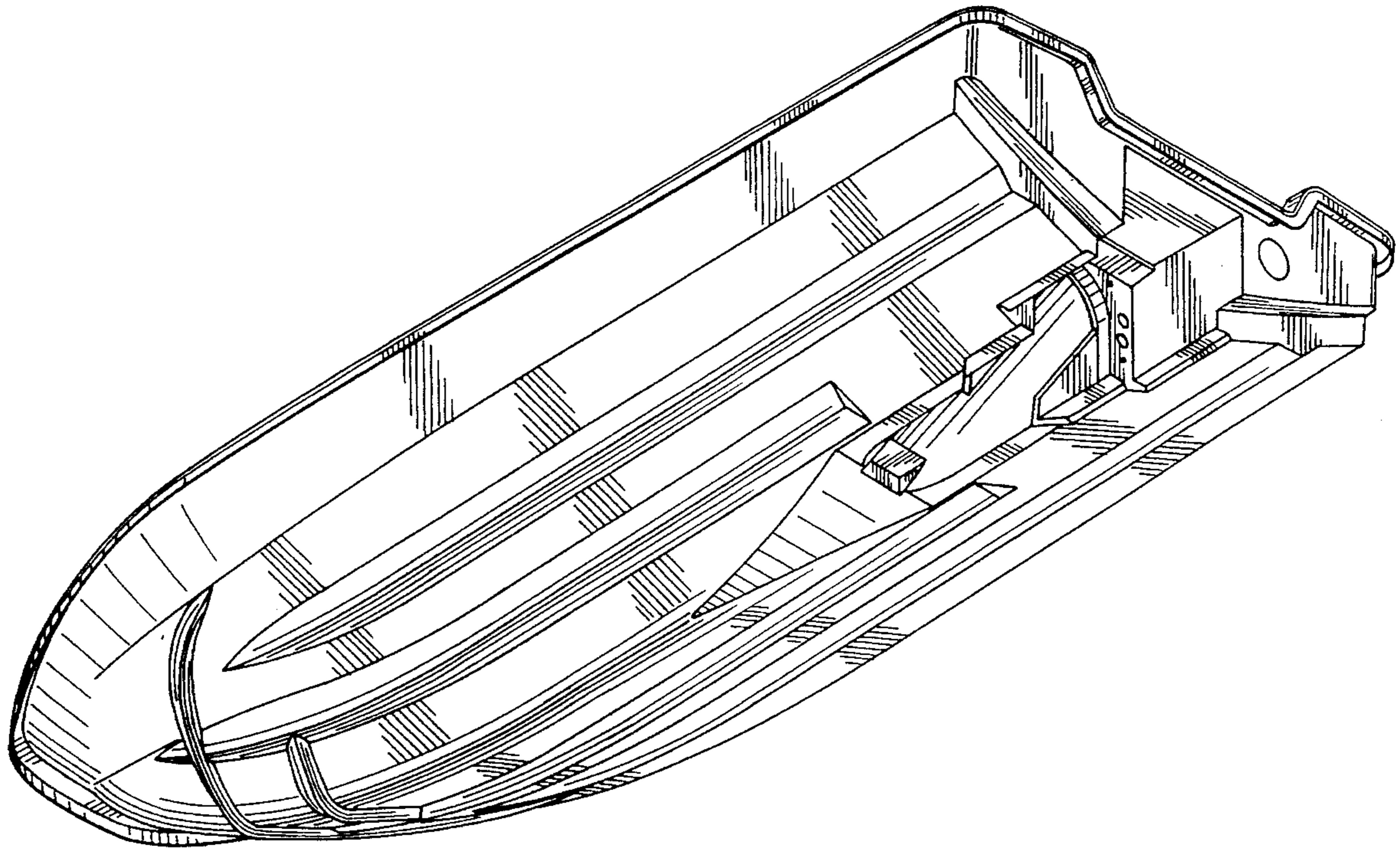

FIG. 1

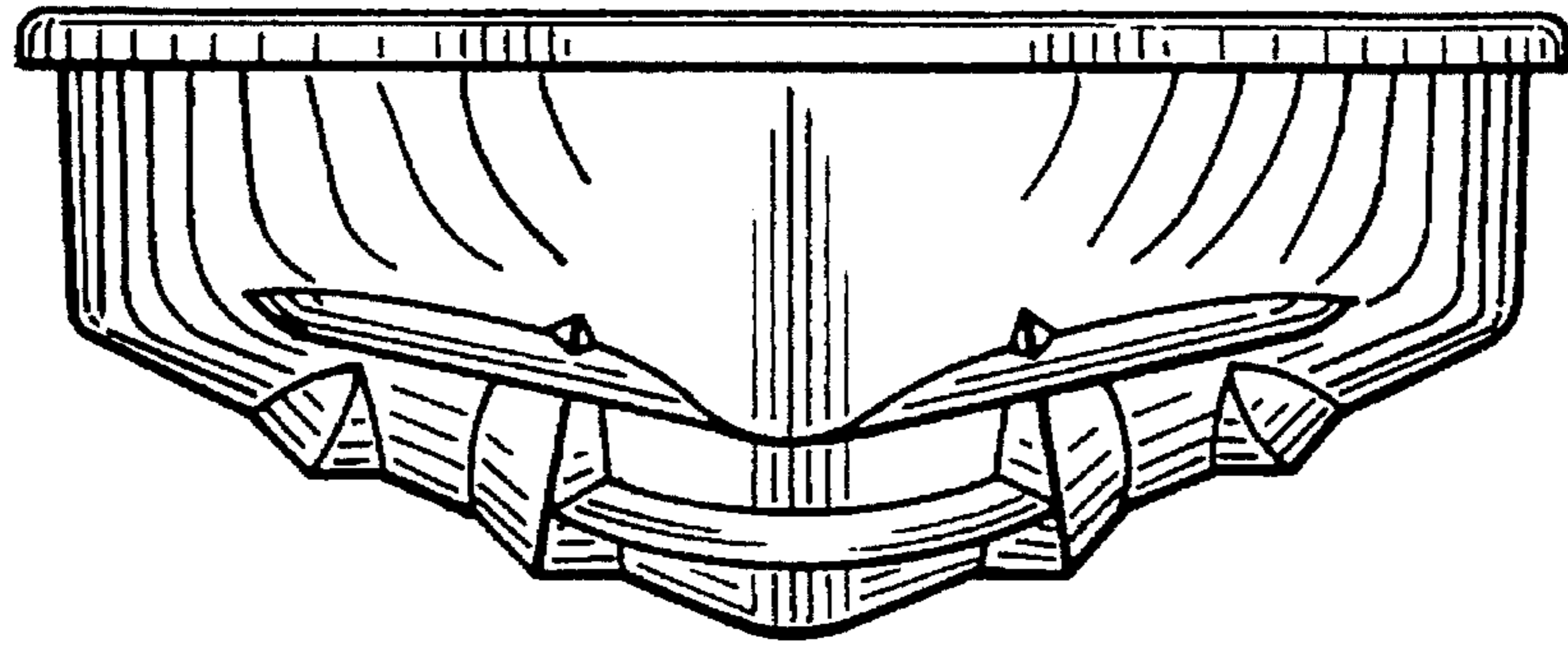

FIG. 2

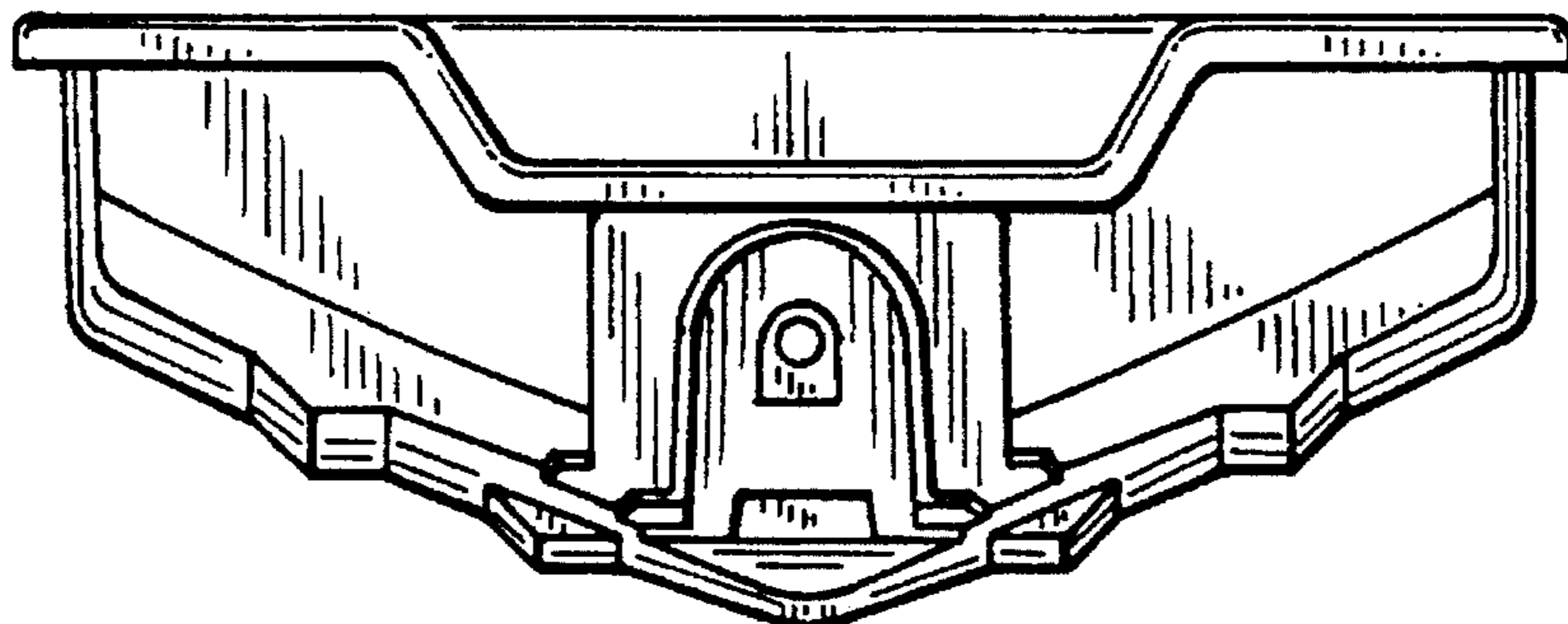

FIG. 3

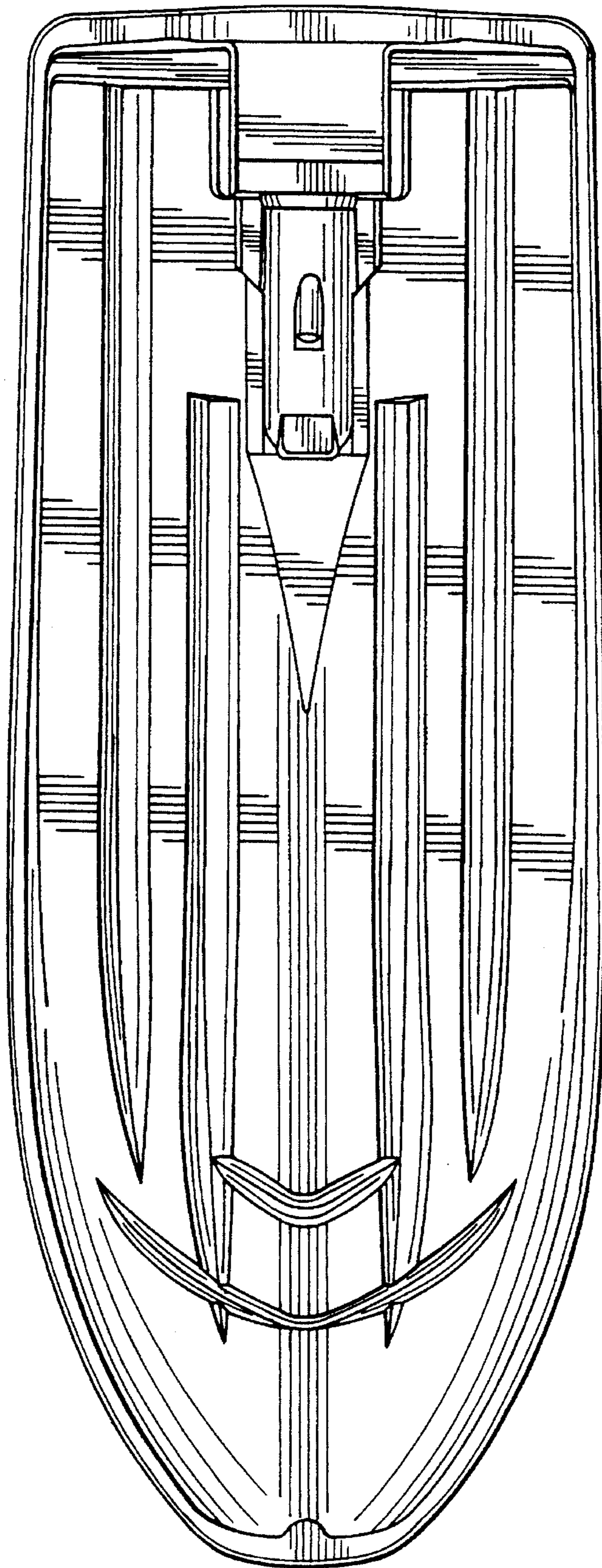

FIG. 4

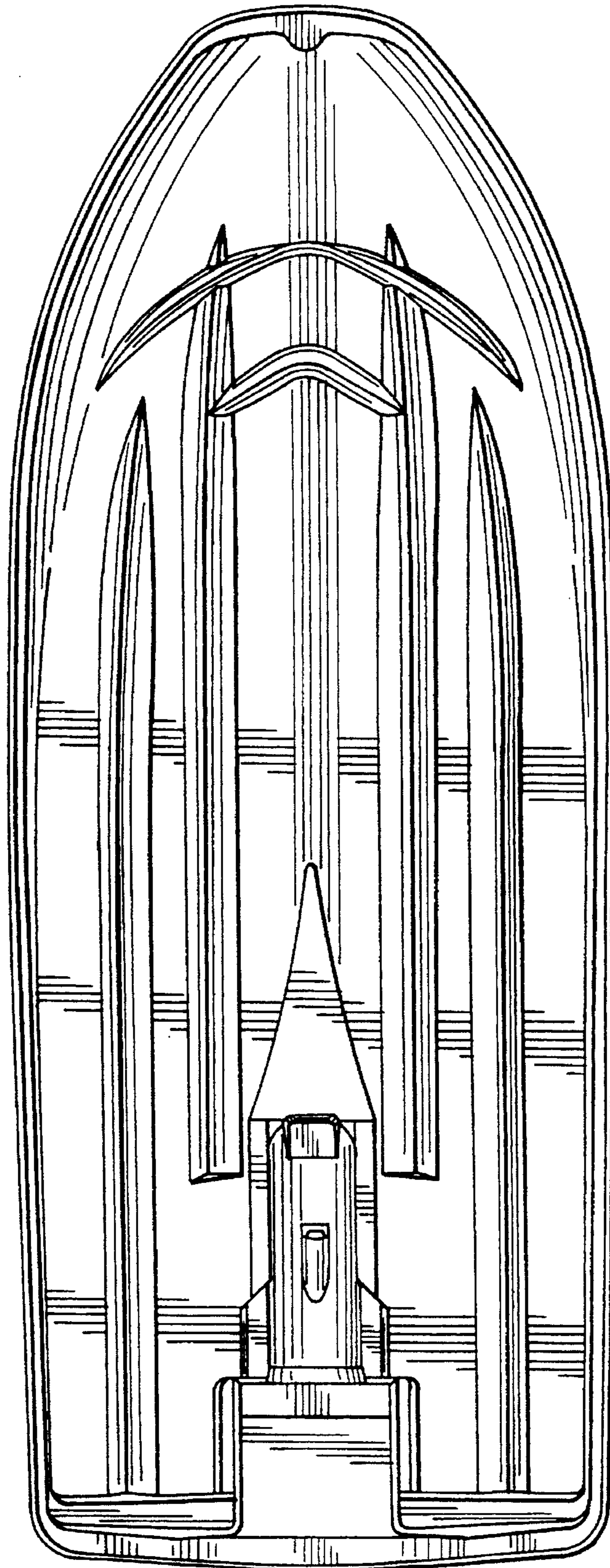
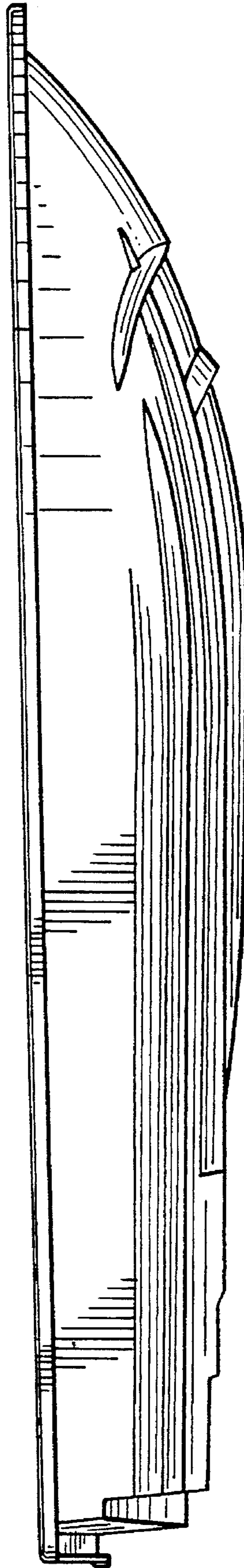

FIG. 5



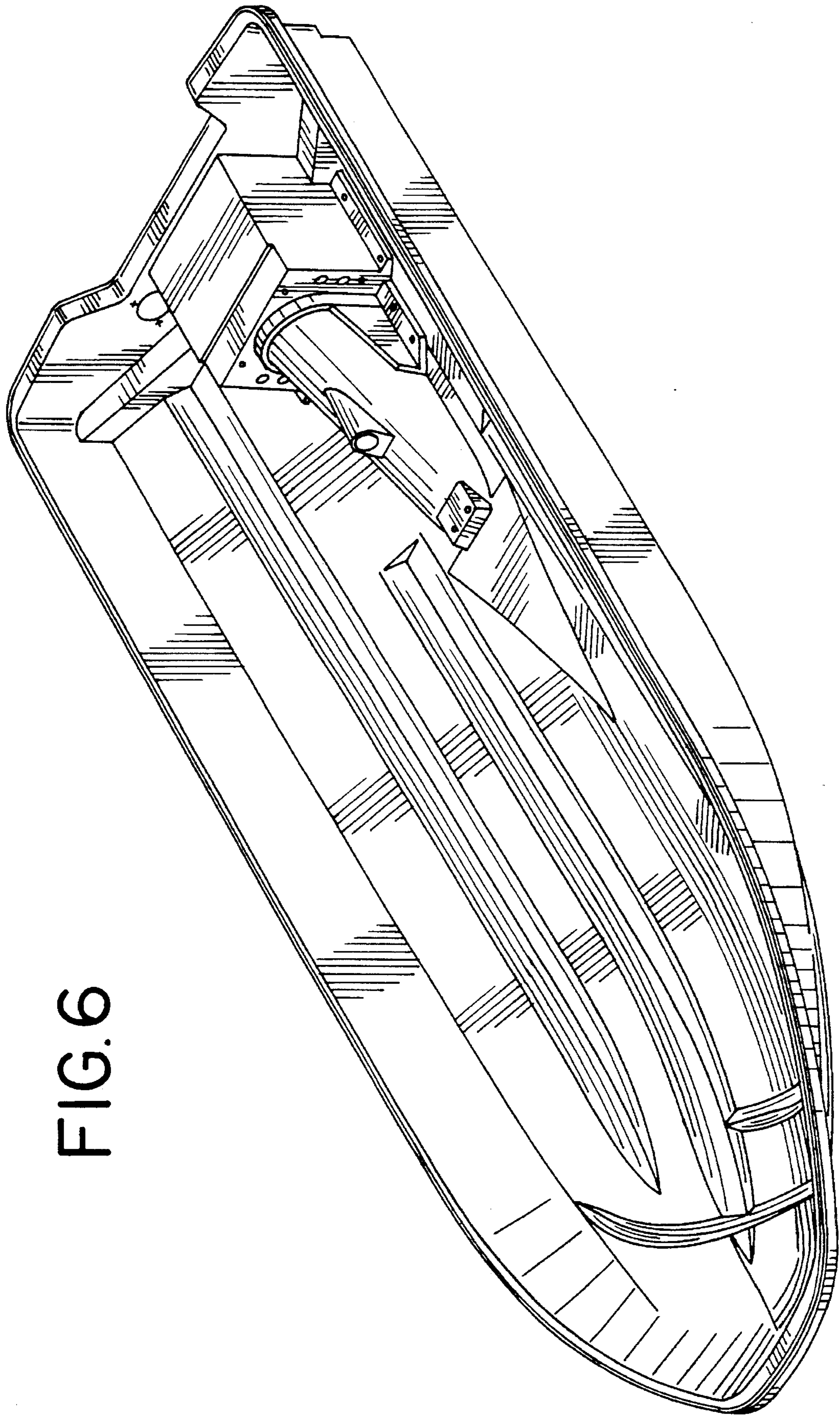

FIG. 6

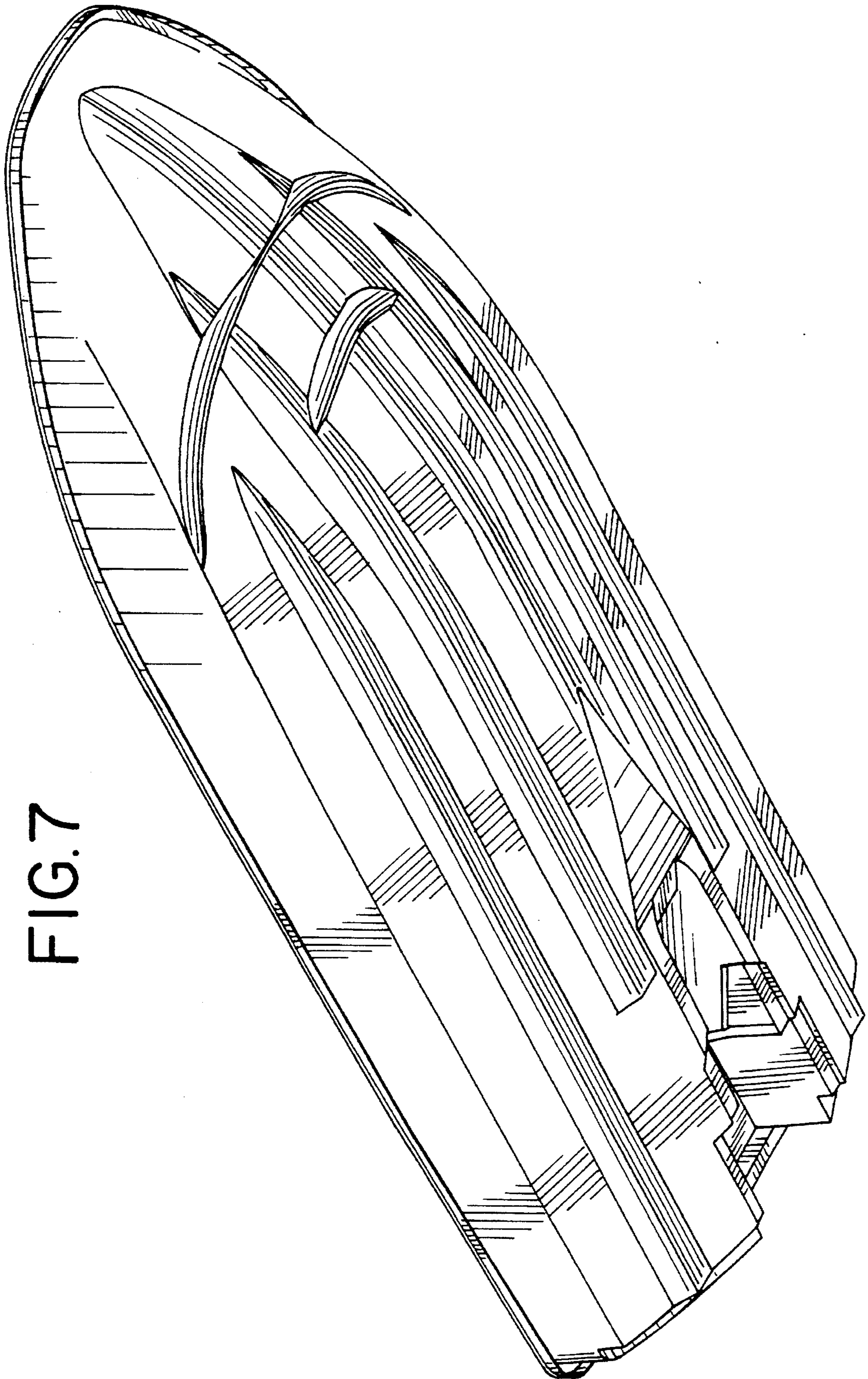

FIG. 7

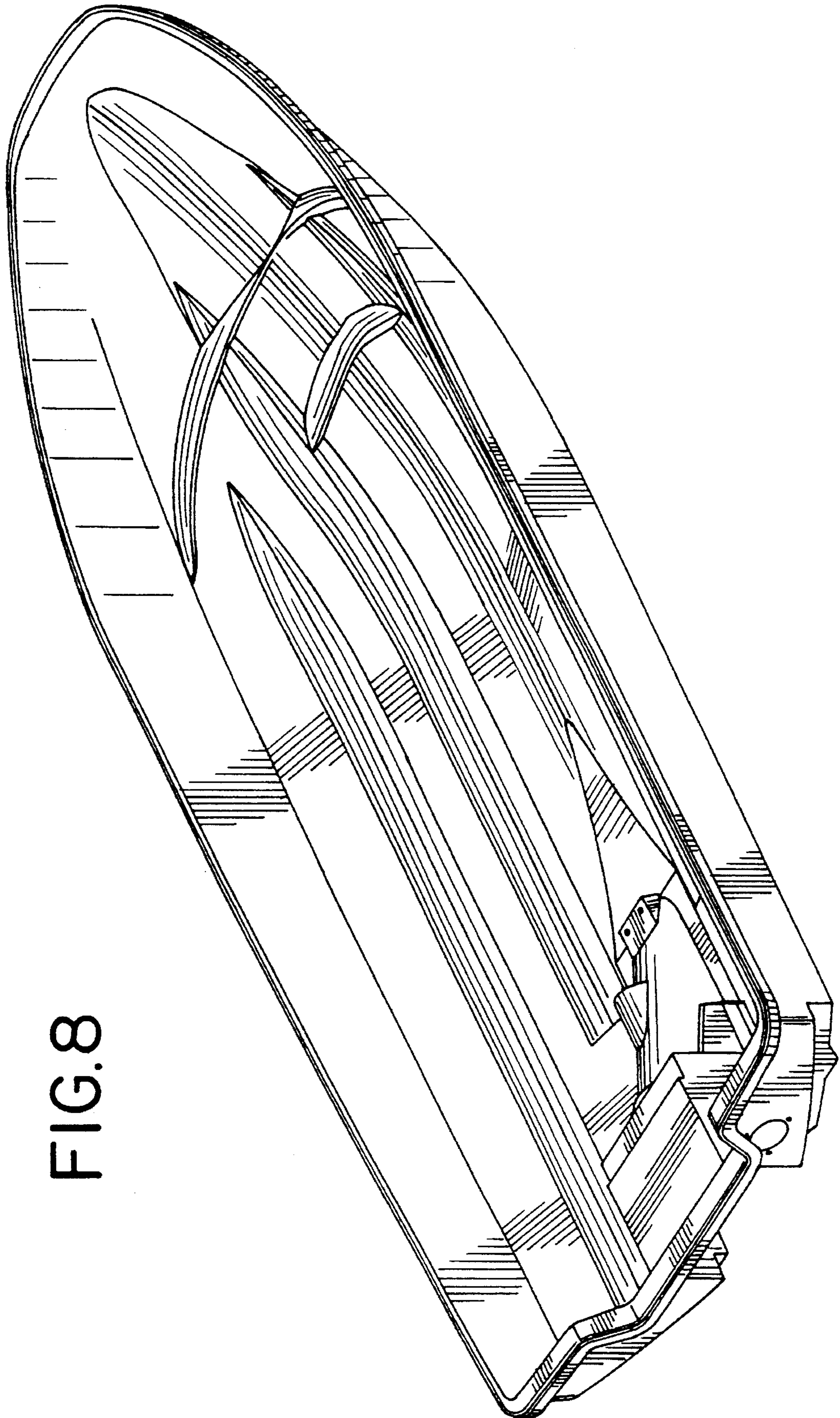

FIG. 8

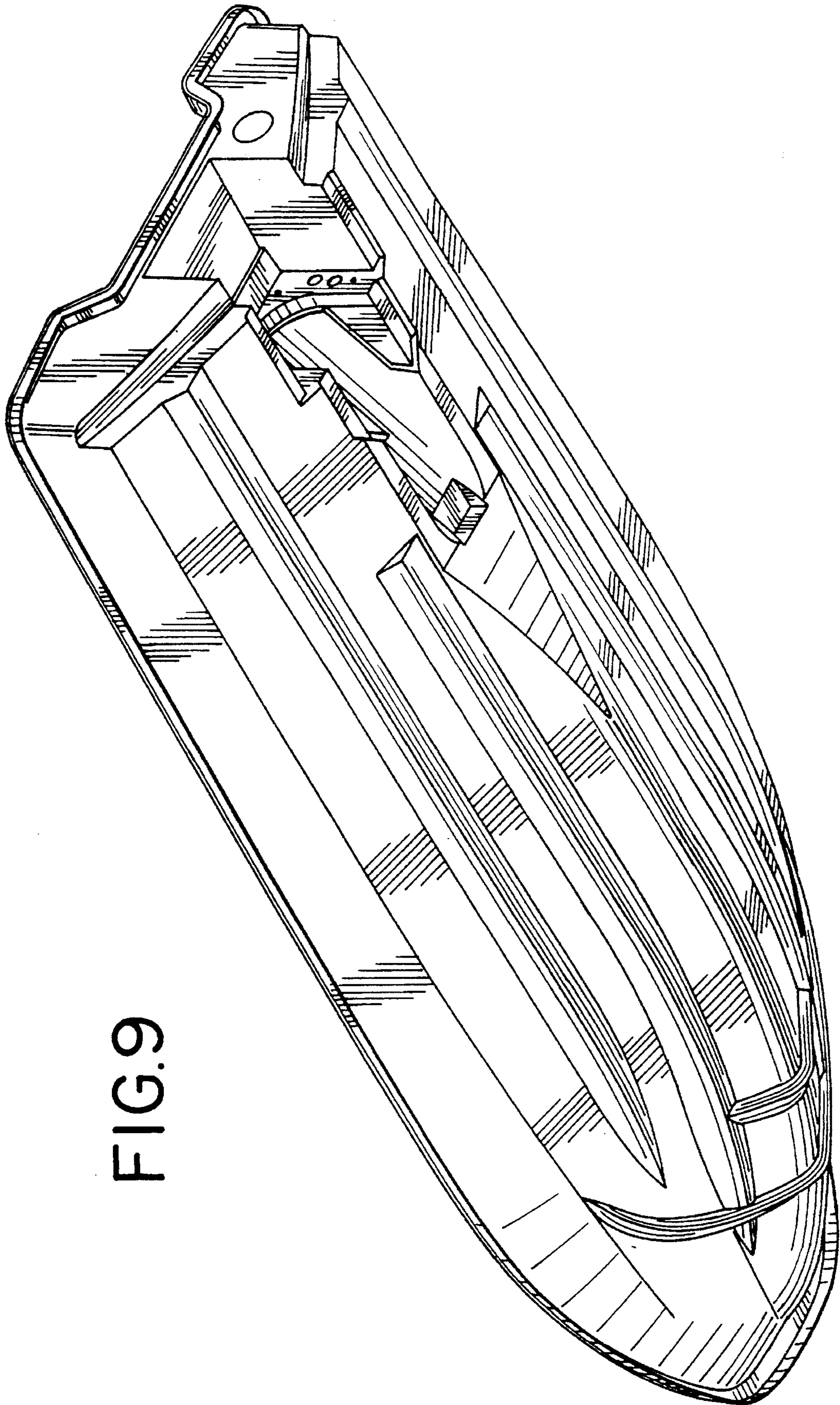

FIG. 9