



US00D369010S

United States Patent [19]
Soederberg

[11] **Patent Number: Des. 369,010**

[45] **Date of Patent: **Apr. 16, 1996**

- [54] **REAR-END OF A FORK LIFT VEHICLE**
- [75] Inventor: **Richard Soederberg**, Muehlacker, Germany
- [73] Assignee: **Dr. Ing. h.c.F. Porsche AG**, Weissach, Germany
- [**] Term: **14 Years**

Primary Examiner—A. Hugo Word
Assistant Examiner—Robin V. Taylor
Attorney, Agent, or Firm—Evenson, McKeown, Edwards & Lenahan

- [21] Appl. No.: **29,066**
- [22] Filed: **Sep. 28, 1994**
- [30] **Foreign Application Priority Data**

Mar. 31, 1994 [DE] Germany 94 02 787.0
 [52] **U.S. Cl.** **D34/34**
 [58] **Field of Search** D34/28, 34, 37;
 414/785, 592, 640; 180/89.14, 89.17, 89.18,
 89.19, 12, 194; 187/222, 237-238

[56] **References Cited**
U.S. PATENT DOCUMENTS

D. 178,343	7/1956	Dorkins	D34/37
D. 231,340	4/1974	Haynes	D34/34
D. 242,337	11/1976	De Priester	D34/37
D. 353,704	12/1994	Bhambra	D34/37

[57] **CLAIM**
 The ornamental design for a rear-end of a fork lift vehicle, as shown and described.

DESCRIPTION

FIG. 1 is a left side view of a rear-end of a fork lift vehicle showing my new design, the right side being a mirror image; FIG. 2 is a left rear perspective view of a rear end of a fork lift according to my novel design; FIG. 3 is a close-up of a left rear perspective view of a rear end of a fork lift according to my novel design; FIG. 4 is a further close-up of a left rear perspective view of a rear end of a fork lift according to my novel design; FIG. 5 is a rear view of the rear end of a fork lift according to my novel design; and, FIG. 6 is a top view of a rear end of a fork lift according to my novel design.
 The broken line showing is for illustrative purposes only and forms no part of the claimed design.

1 Claim, 3 Drawing Sheets

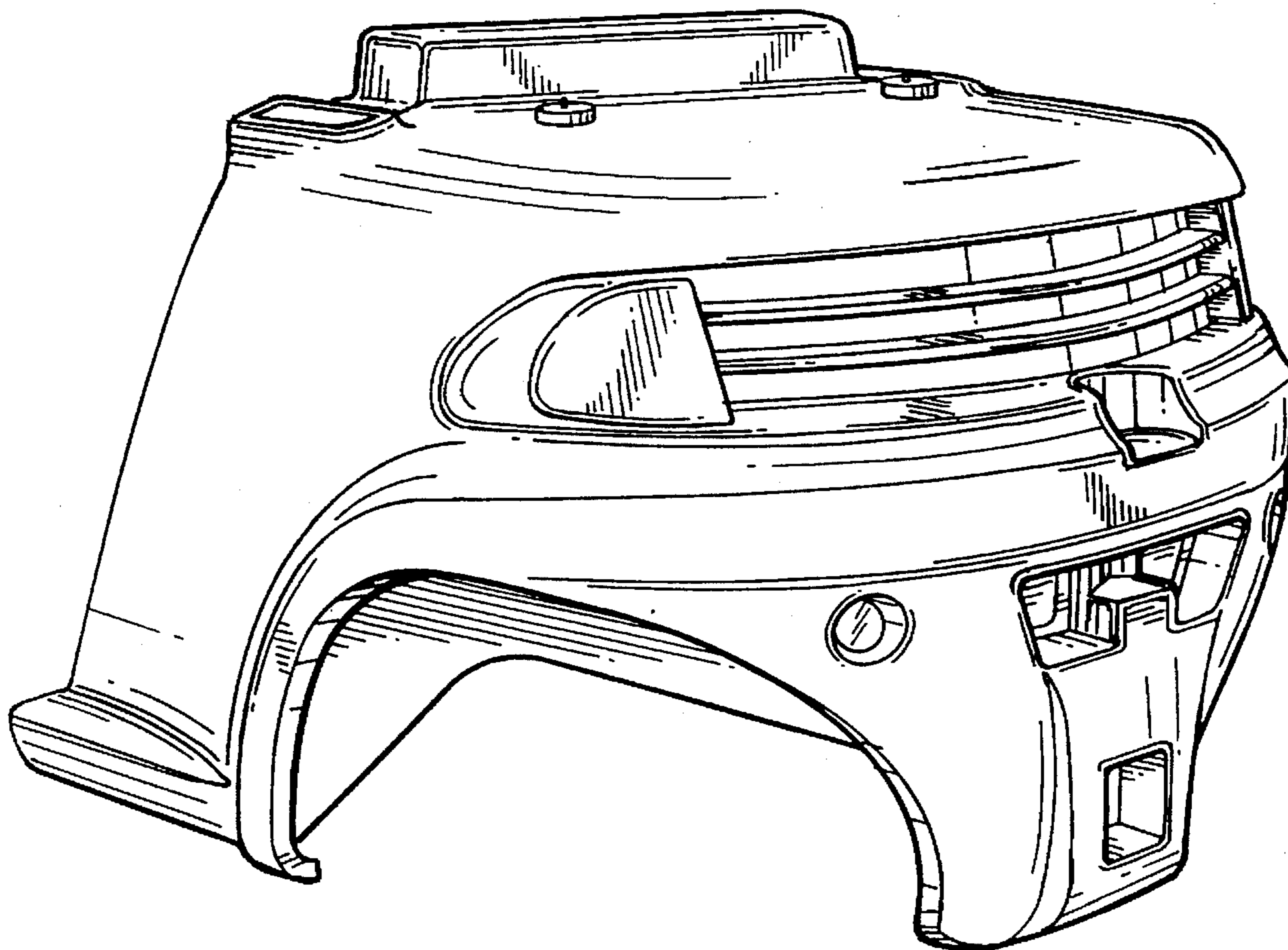

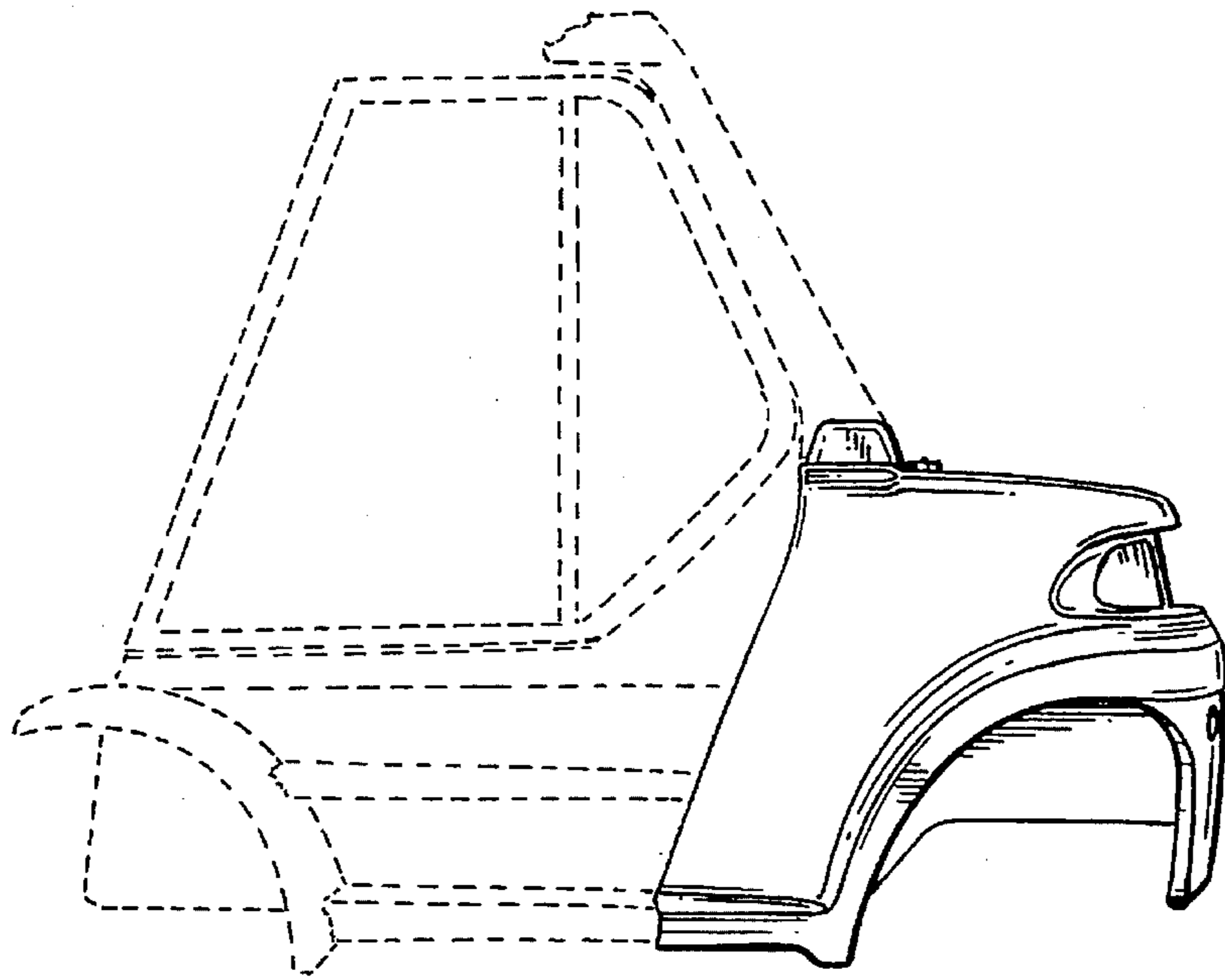

FIG. 1

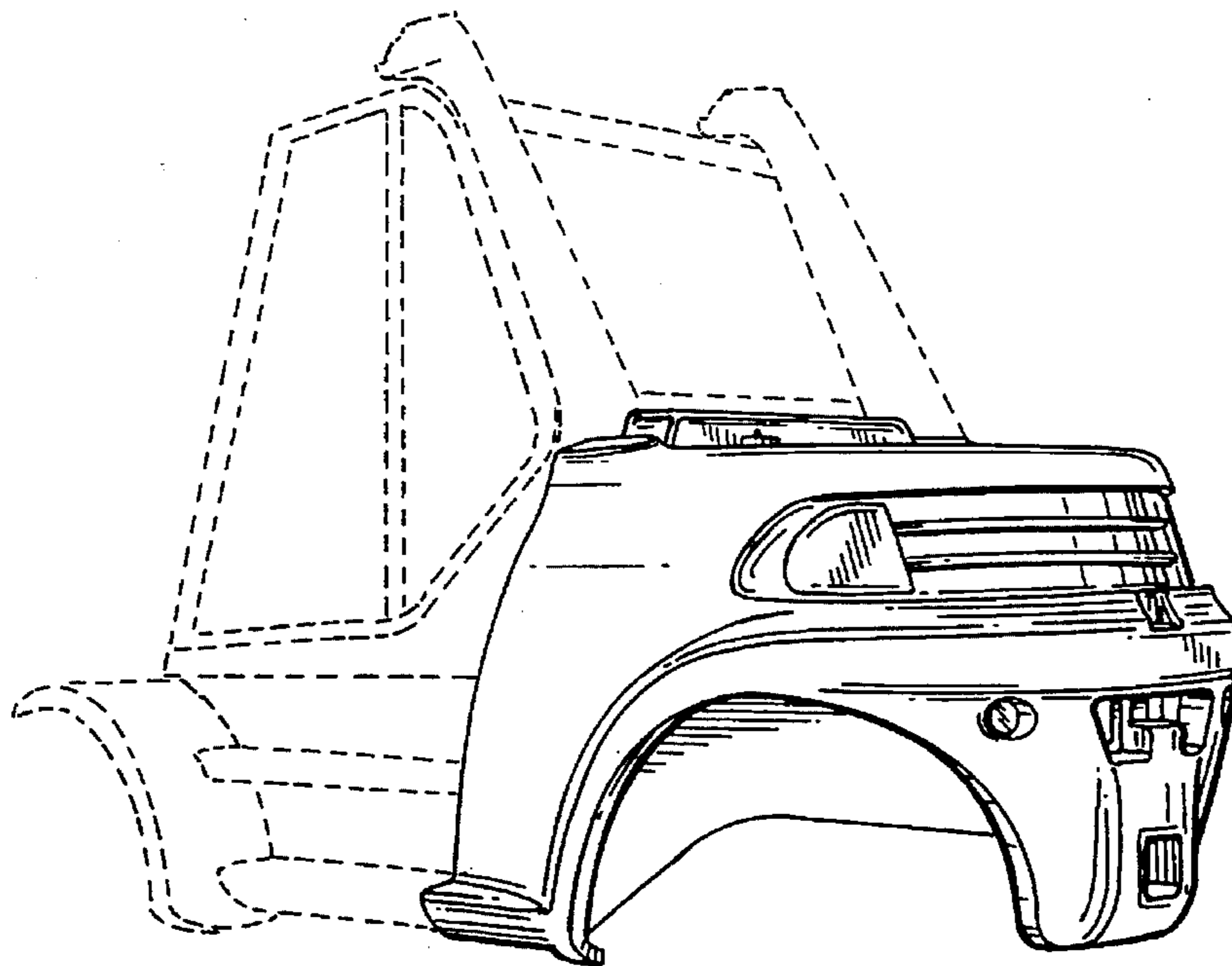

FIG. 2

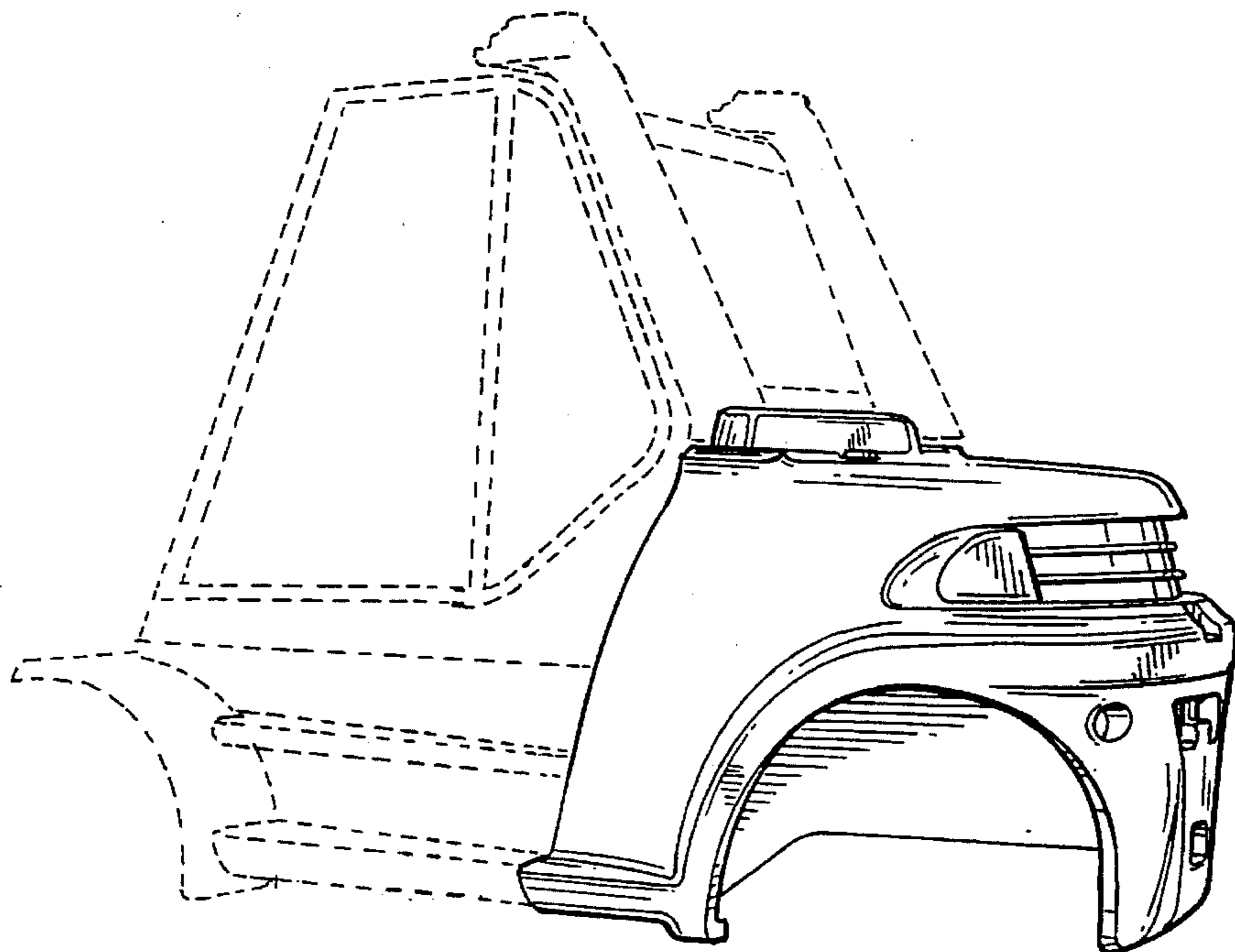

FIG. 3

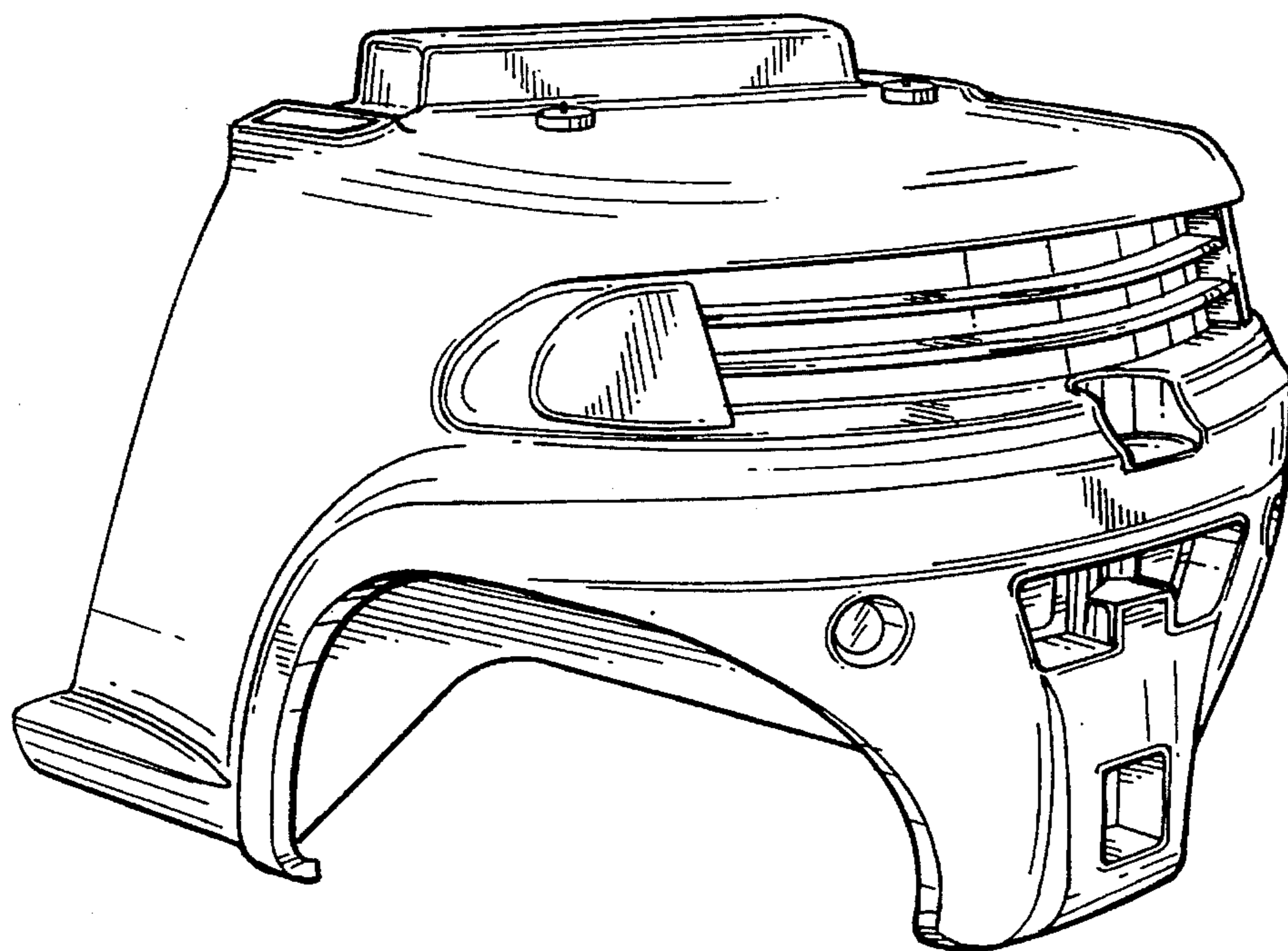

FIG. 4

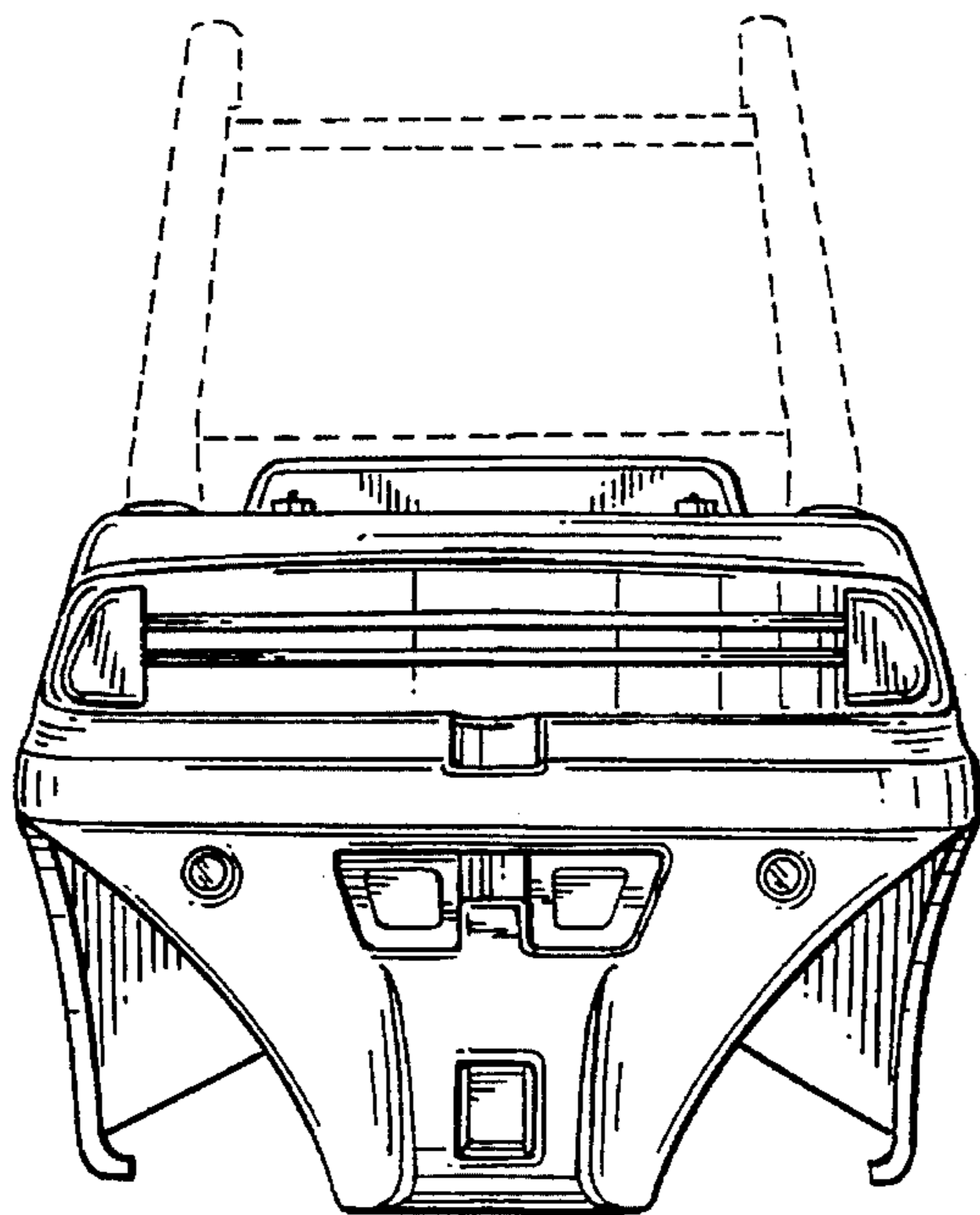

FIG. 5

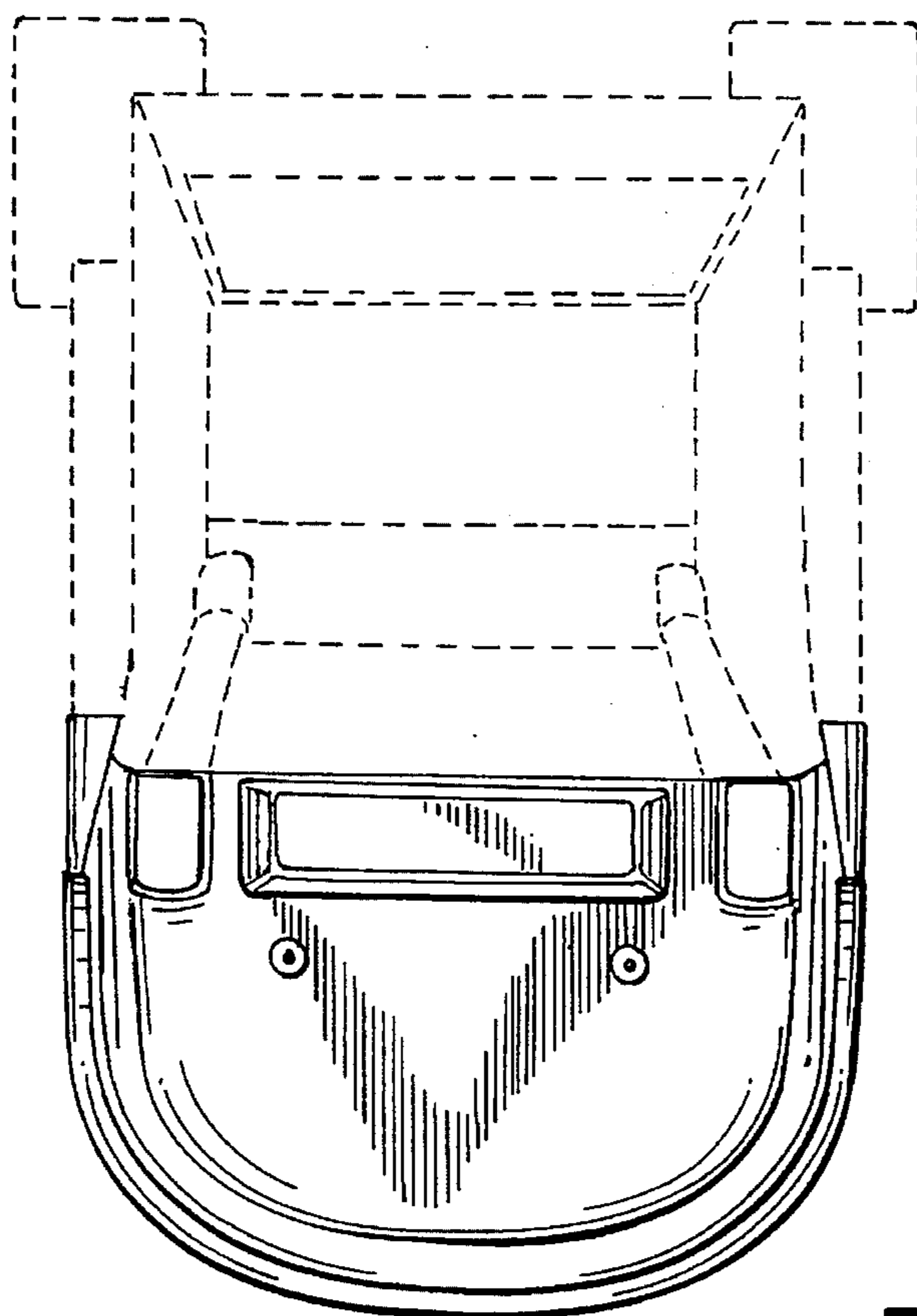

FIG. 6