



US00D368880S

**United States Patent** [19]  
**Harrington**

[11] **Patent Number: Des. 368,880**  
[45] **Date of Patent: \*\*Apr. 16, 1996**

[54] **REAR SUSPENSION PORTION OF A BICYCLE FRAME**

[76] Inventor: **Jeffrey M. Harrington**, 370 Altair Way, #140, Sunnyvale, Calif. 94086

[\*\*] Term: **14 Years**

[21] Appl. No.: **28,218**

[22] Filed: **Sep. 9, 1994**

[52] U.S. Cl. .... **D12/117; D12/111**

[58] Field of Search ..... **D12/111, 110, D12/117; 280/284, 283, 275, 286, 288**

[56] **References Cited**

**U.S. PATENT DOCUMENTS**

5,121,937	6/1992	Lawhill	280/284
5,259,637	11/1993	Busby	280/284
5,306,036	4/1994	Busby	280/284
5,409,249	10/1983	Busby	280/284

**OTHER PUBLICATIONS**

Trek suspension Track seen in Trek Bicycle Corporation brochure dated 1994.

Future Shock FSX suspension system seen in Specialized Bicycle Components, Inc. brochure dated 1994.

Headshock suspension systems seen in Cannondale Corporation brochure dated 1993.

Nishiki bicycle suspension system seen in Derby Bicycle Corporation brochure dated 1993.

Sonoma suspension system seen in Crosstrac brochure dated Oct. 1993.

Marzocchi suspension system seen in Diamond Back brochure dated 1994.

GT's Rocker Tuned Suspension System seen in the GT Bicycles, Inc. brochure dated 1993.

*Primary Examiner*—A. Hugo Word

*Assistant Examiner*—M. Brown

*Attorney, Agent, or Firm*—Hawes & Fischer

[57] **CLAIM**

The ornamental design for a rear suspension portion of a bicycle frame, as shown and described.

**DESCRIPTION**

FIG. 1 is a left side elevation of a rear suspension portion of a bicycle frame of our new design, the broken lines representing the remainder of a bicycle; is shown for illustrative purposes only and form no part of the claimed design;

FIG. 2 is a left perspective view thereof with broken lines representing a portion of a bicycle being shown for illustrative purposes only and form no part of the claimed design;

FIG. 3 is a top plan view thereof;

FIG. 4 is a right side elevation view thereof;

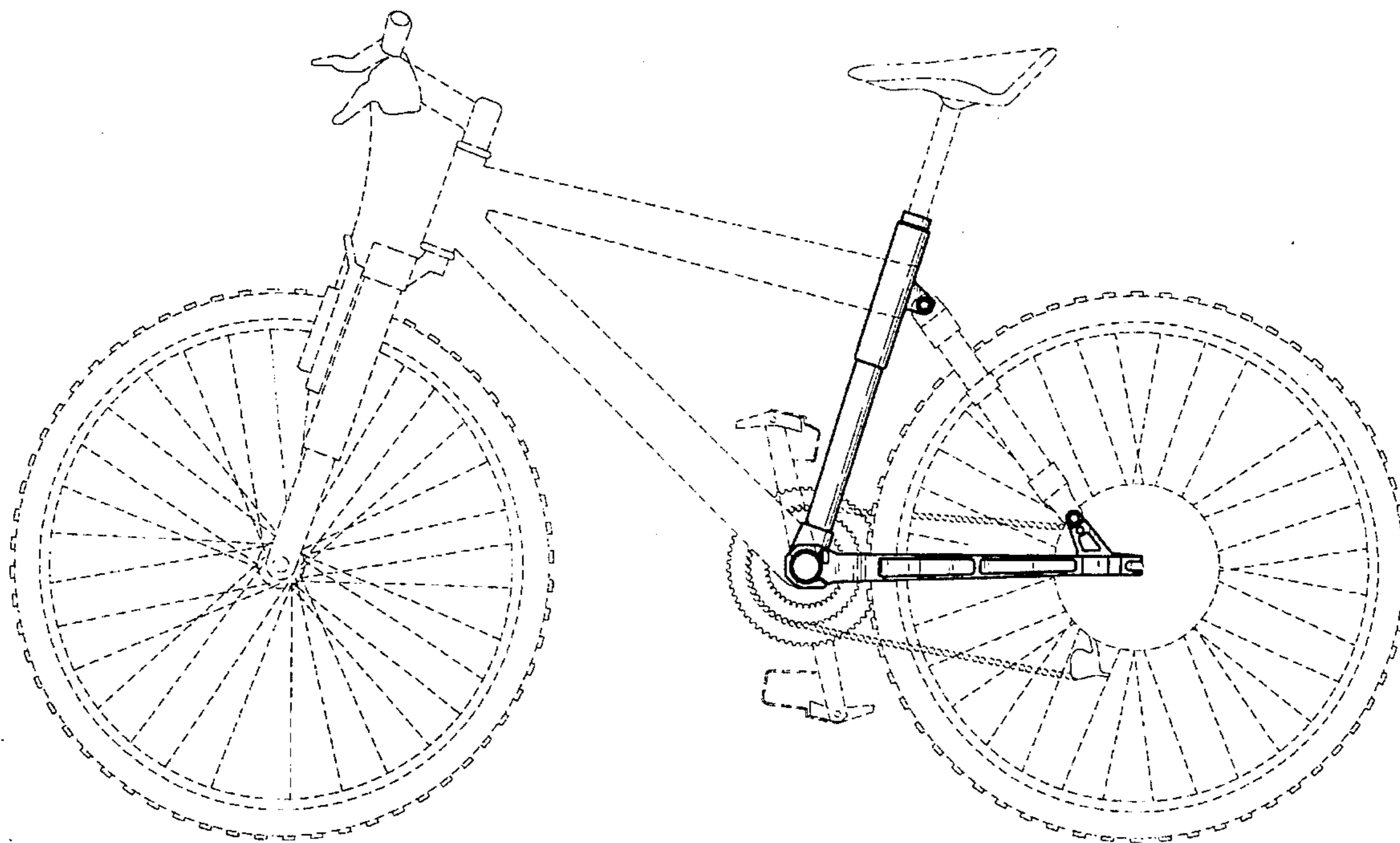
FIG. 5 is a rear elevation thereof;

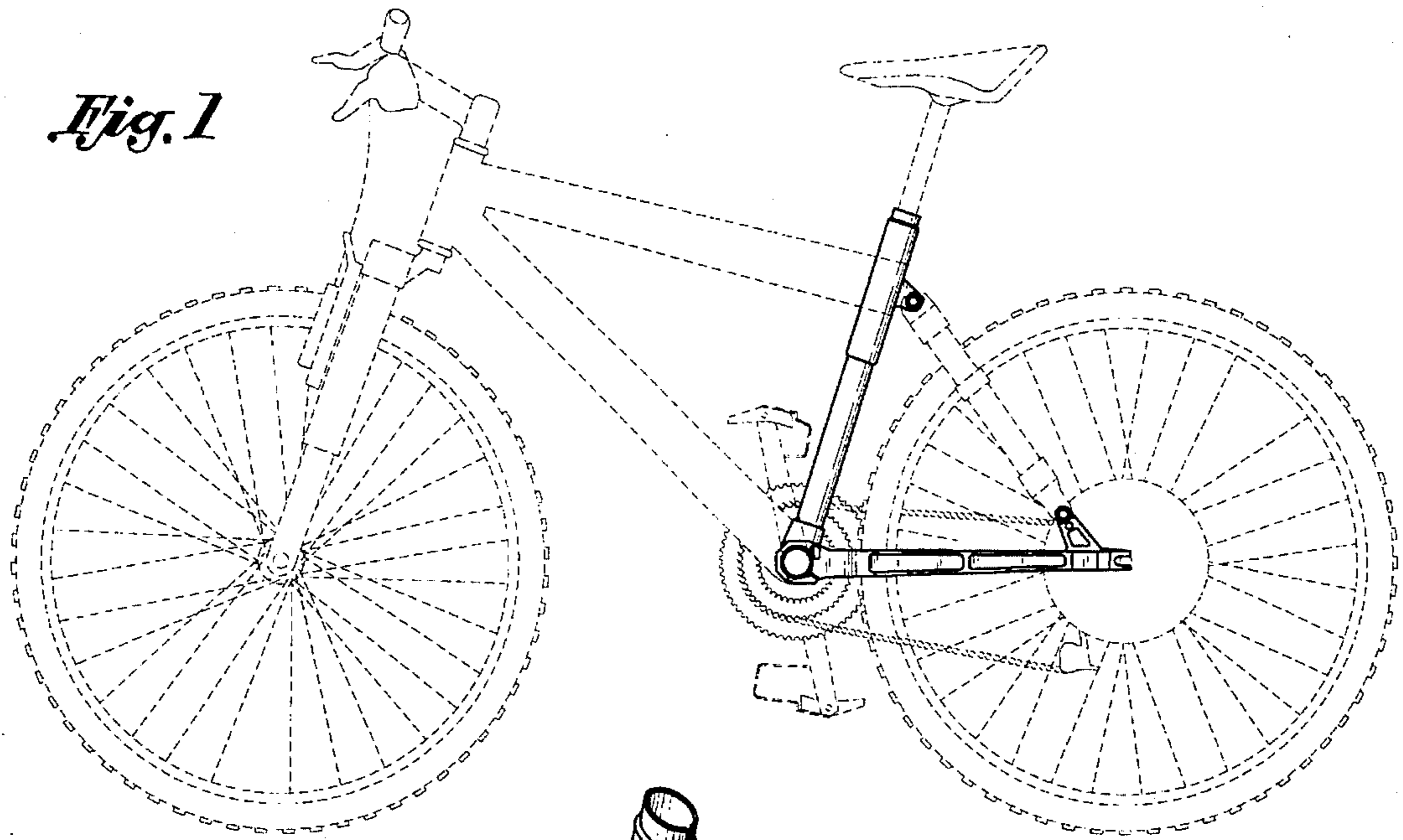
FIG. 6 is a bottom plan view thereof;

FIG. 7 is a right side elevation view thereof; and,

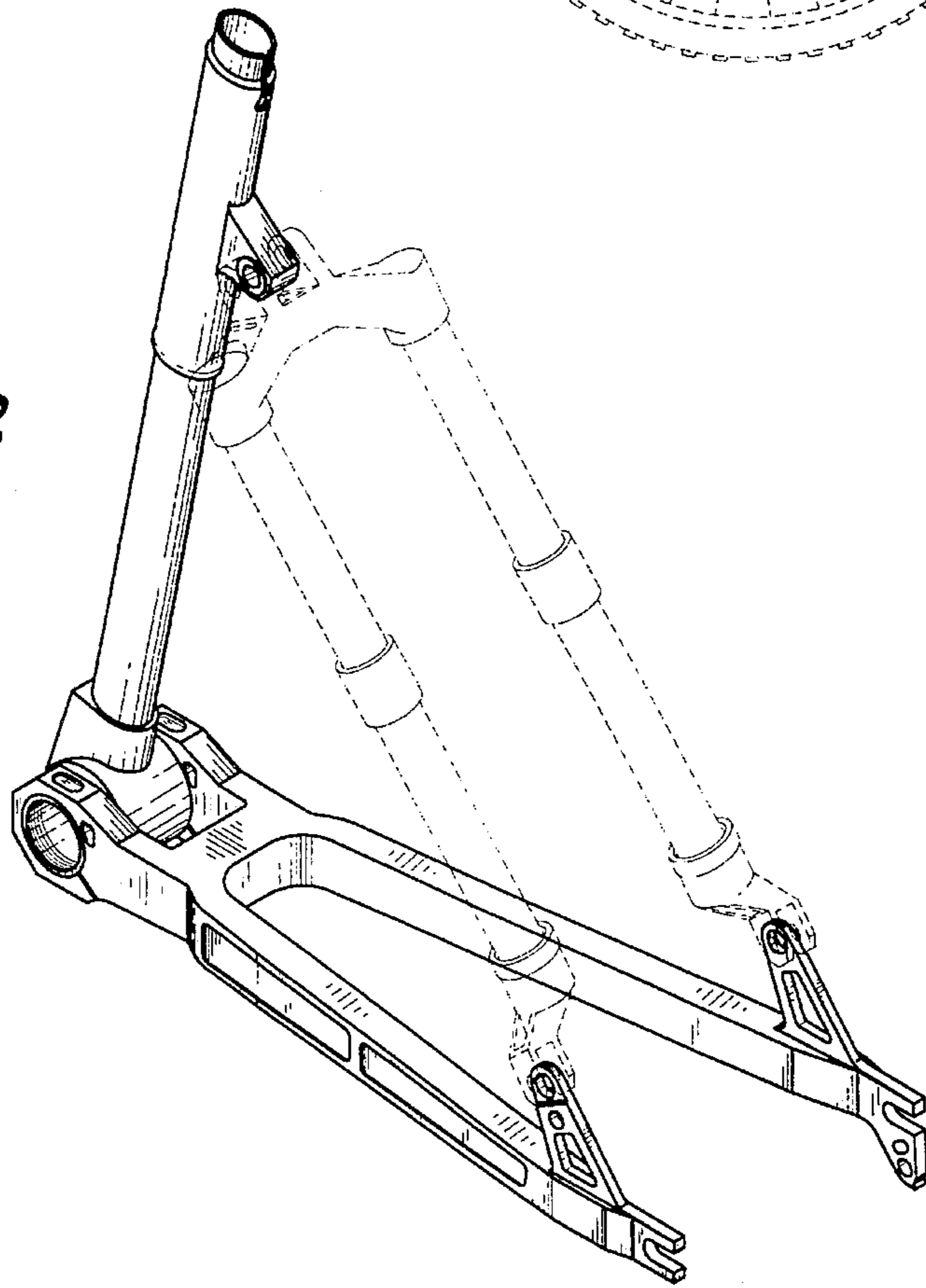
FIG. 8 is a front elevation thereof.

**1 Claim, 3 Drawing Sheets**

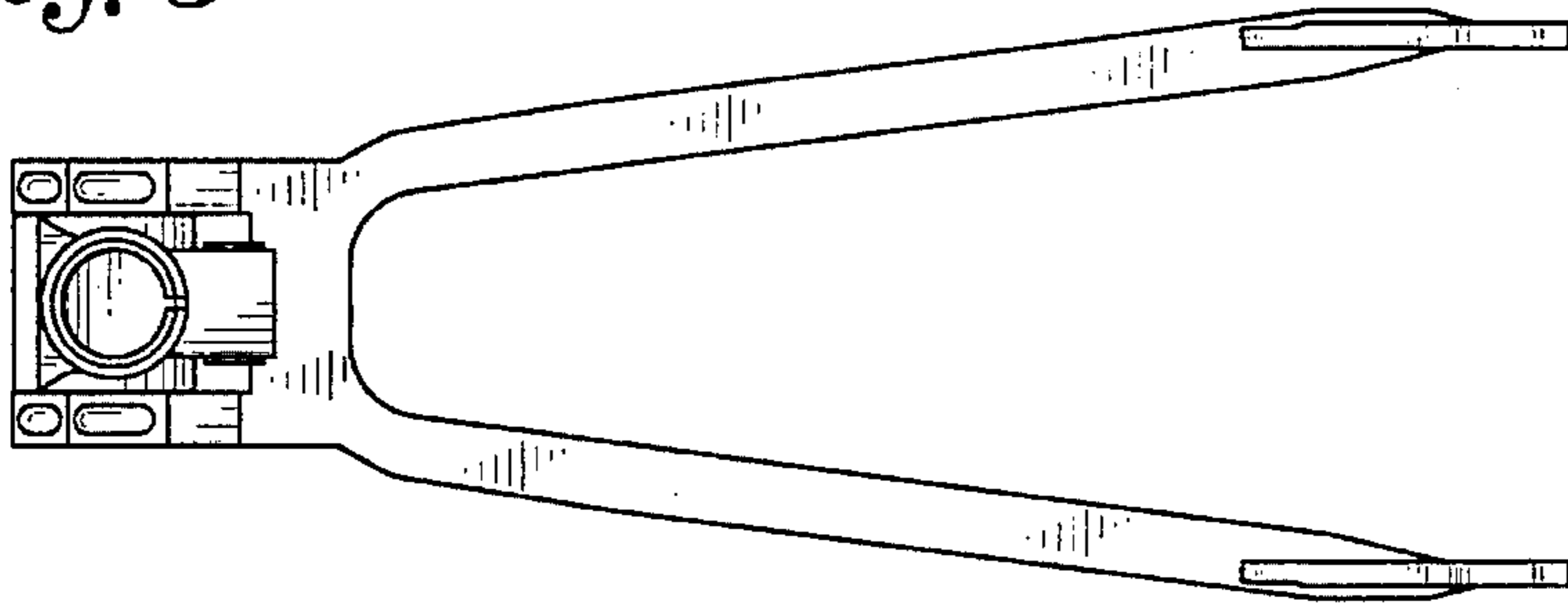




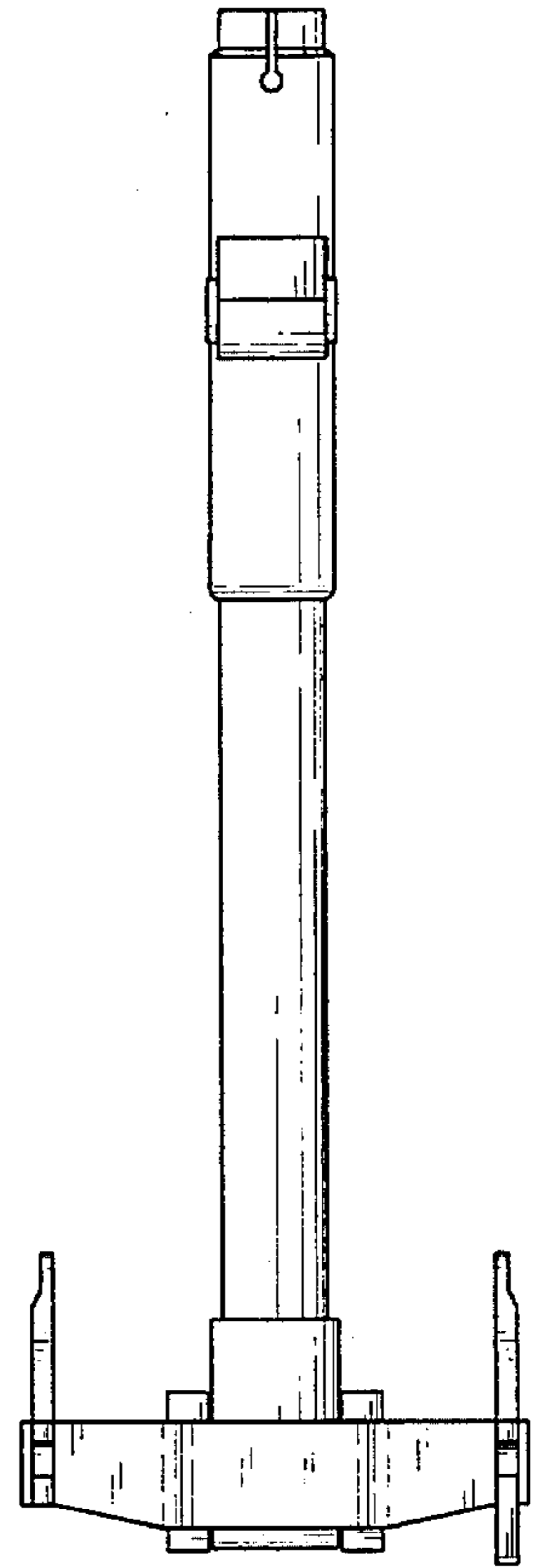
*Fig. 2*



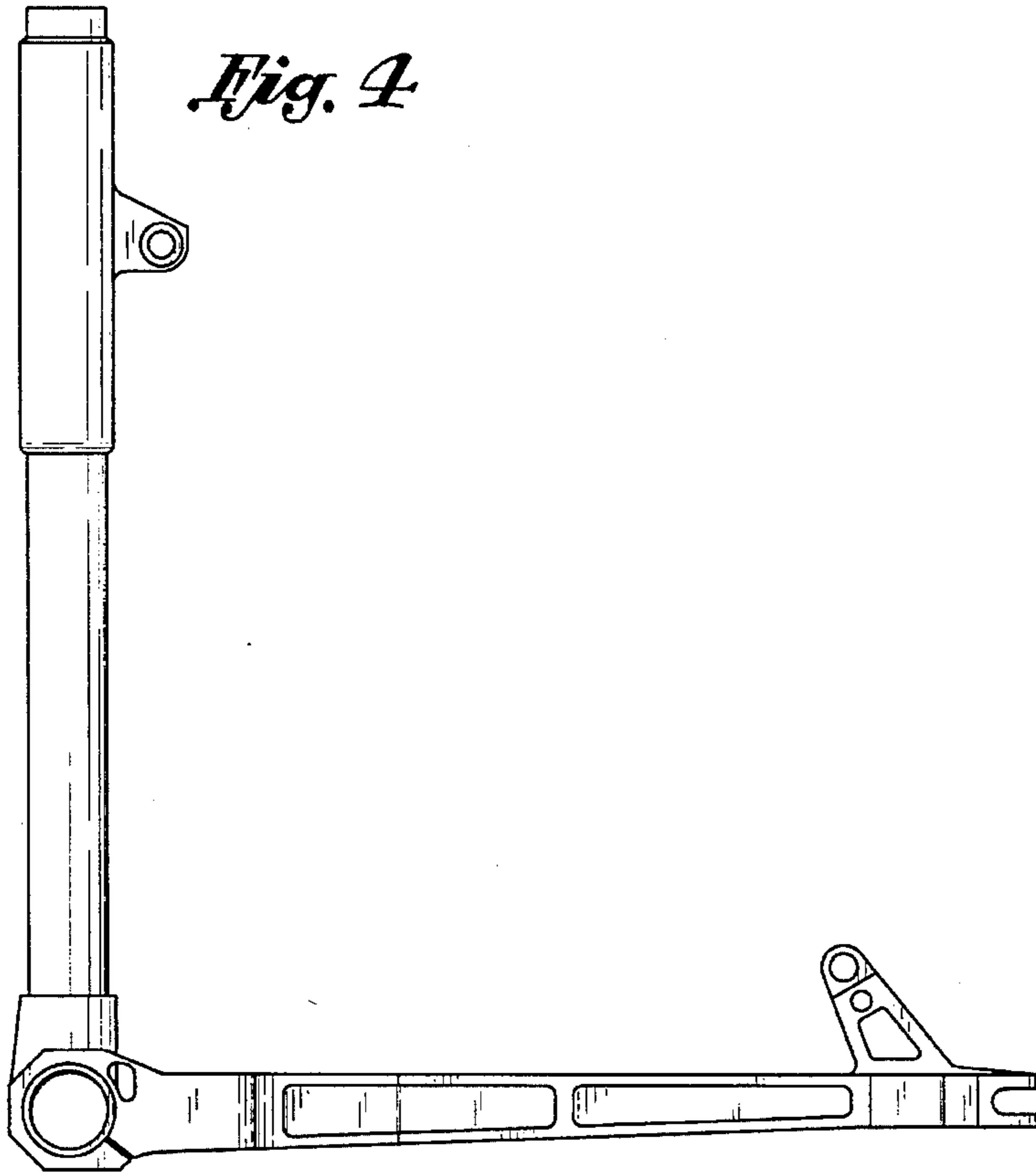
*Fig. 3*



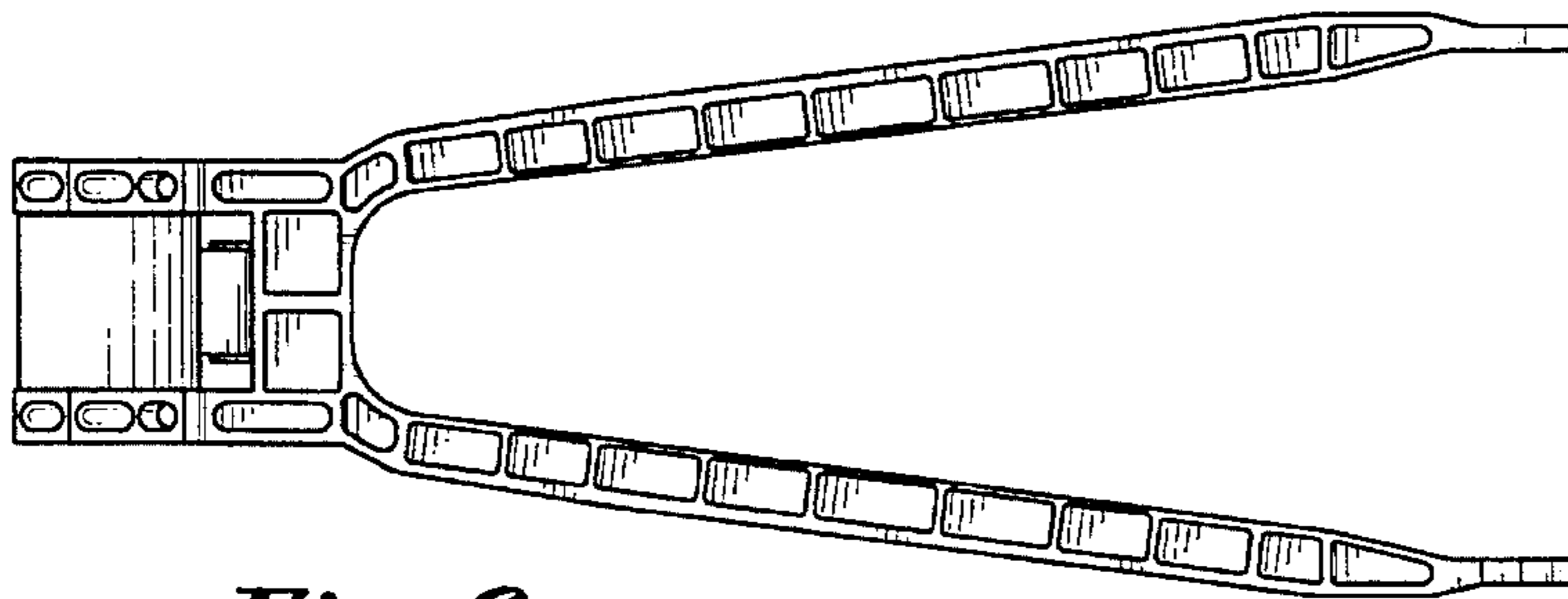
*Fig. 5*



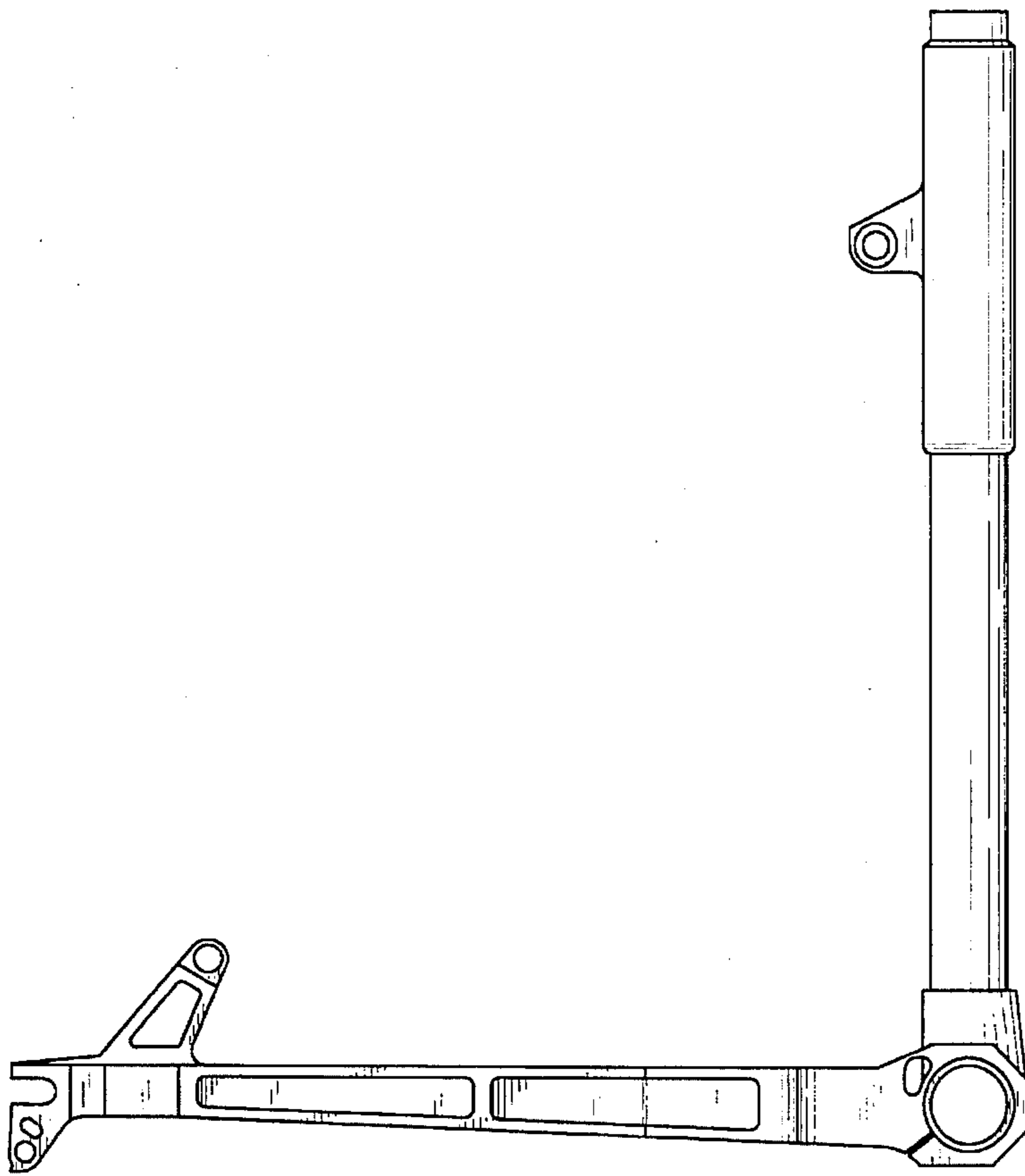
*Fig. 4*



*Fig. 6*



*Fig. 7*



*Fig. 8*

