



US00D368698S

United States Patent [19]
Myers

[11] **Patent Number: Des. 368,698**
[45] **Date of Patent: **Apr. 9, 1996**

[54] **MOTORCYCLE IGNITION SWITCH AND STEERING LOCK**

[75] Inventor: **Gary L. Myers, Monee, Ill.**

[73] Assignee: **Fort Lock Corporation, River Grove, Ill.**

[**] Term: **14 Years**

[21] Appl. No.: **19,924**

[22] Filed: **Mar. 15, 1994**

[52] U.S. Cl. **D13/158**

[58] Field of Search **D13/126, 158; 70/252; 180/271, 287; 200/43.03**

[56] **References Cited**

U.S. PATENT DOCUMENTS

5,197,312 3/1993 Akutsu 70/252 X

5,291,067 3/1994 Nakajima et al. 70/252 X

Primary Examiner—Joel Sincavage
Attorney, Agent, or Firm—Leydig, Voit & Mayer

[57] **CLAIM**

The ornamental design for a motorcycle ignition switch and steering lock, as shown and described.

DESCRIPTION

FIG. 1 is a top perspective view of a motorcycle ignition switch and steering lock showing my new design; FIG. 2 is a rear side elevational view thereof; FIG. 3 is a left side elevational view thereof; FIG. 4 is a front side elevational view thereof; FIG. 5 is a top plan view thereof; FIG. 6 is a bottom plan view thereof; and, FIG. 7 is a rear upper perspective view thereof.

1 Claim, 4 Drawing Sheets

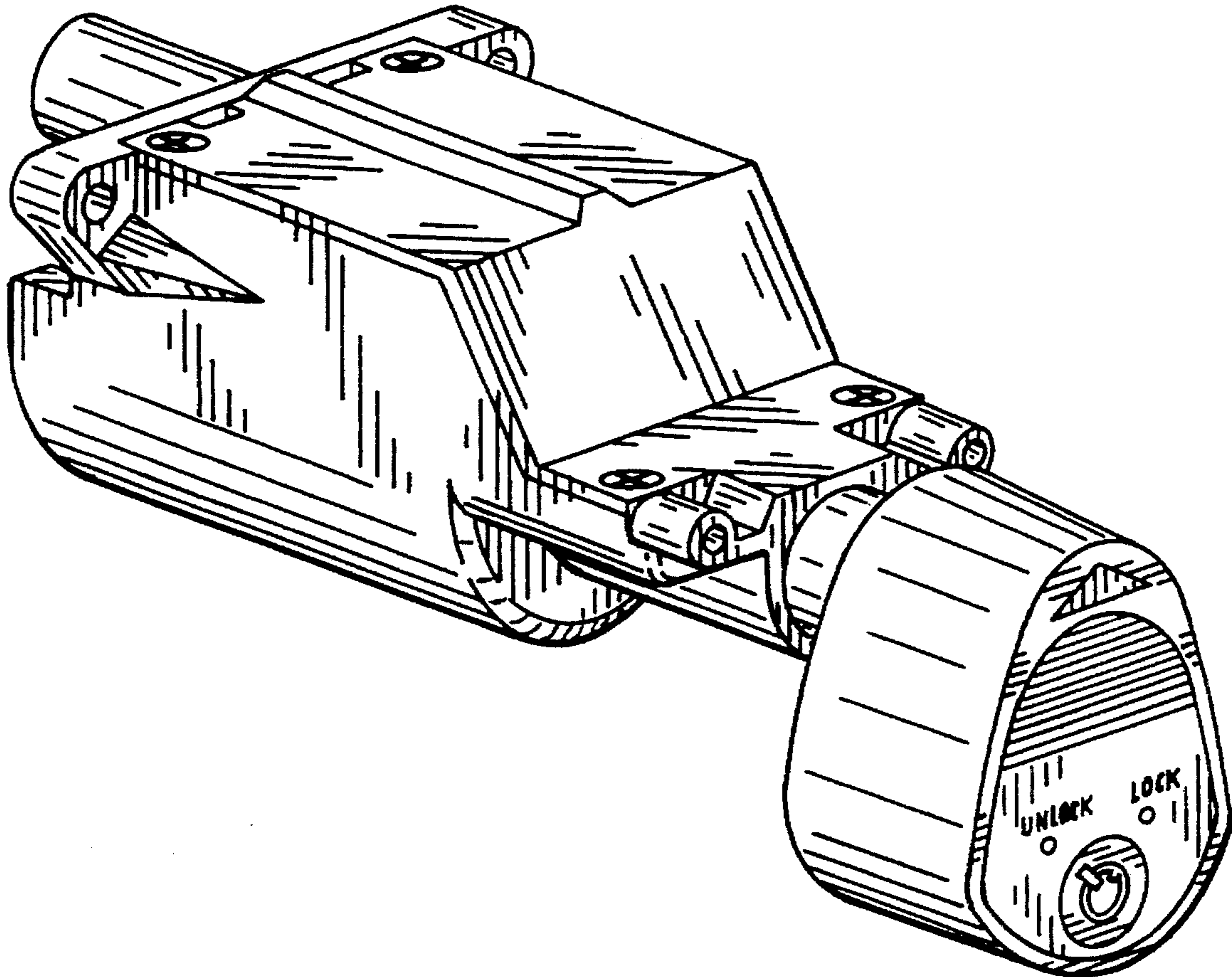

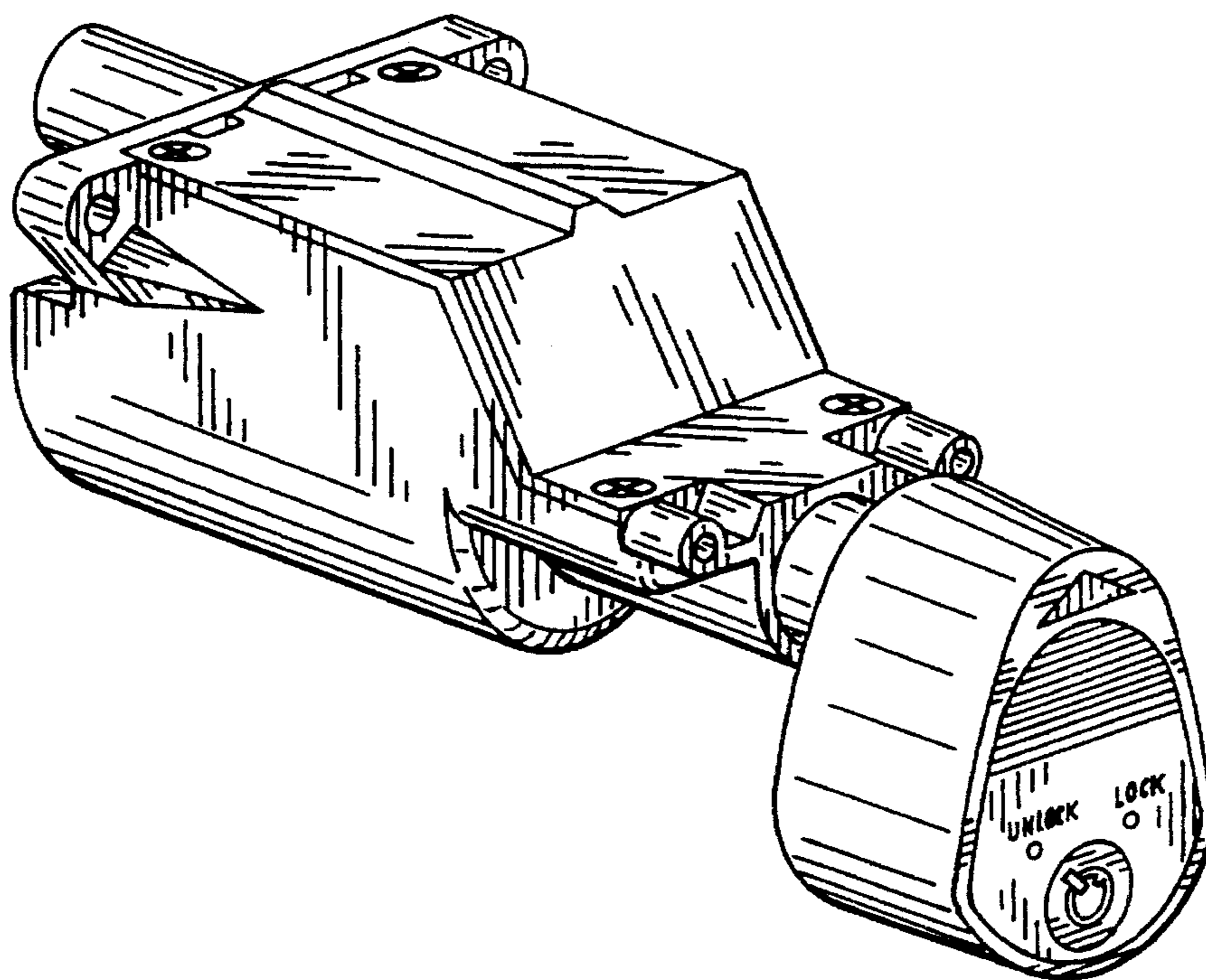

FIG. 1

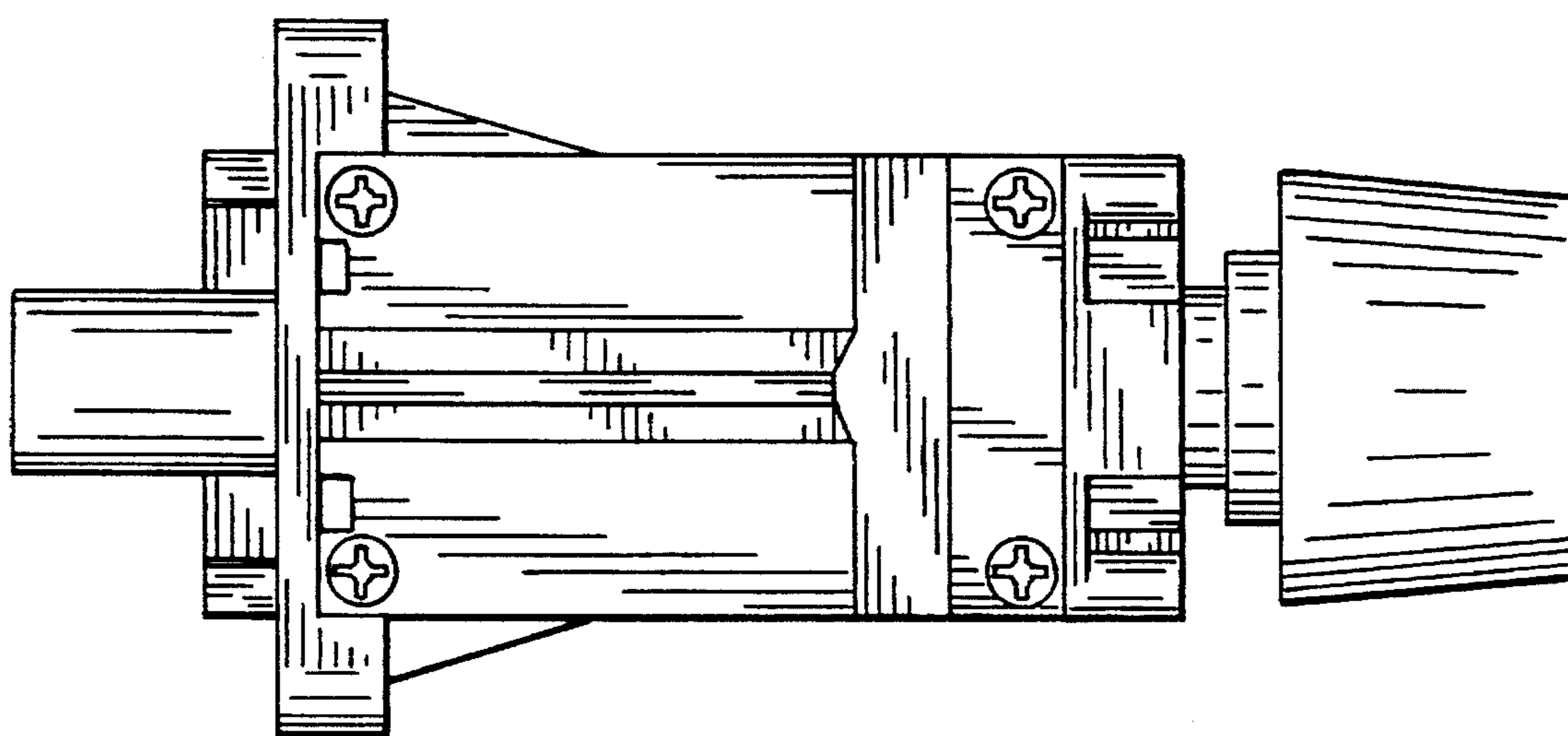

FIG. 2

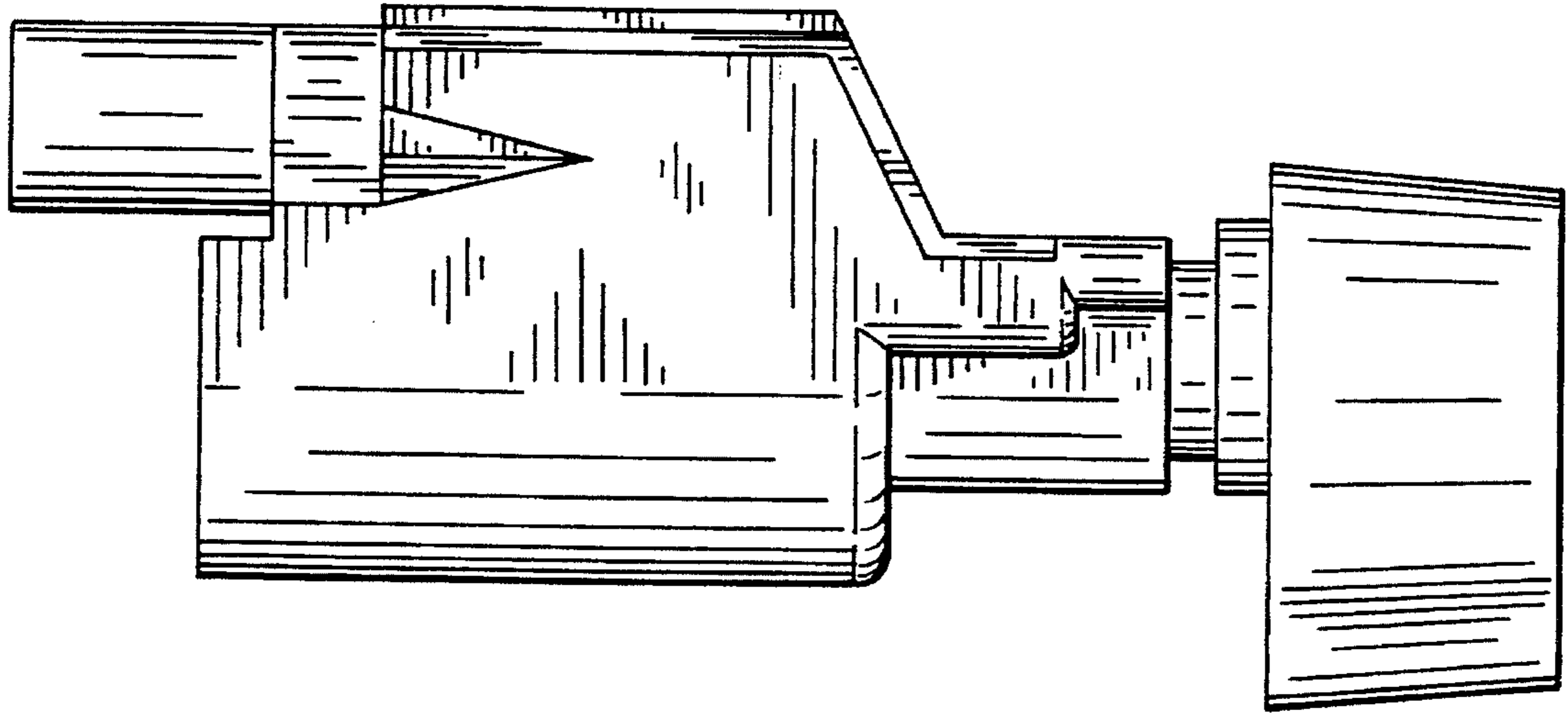

FIG. 3

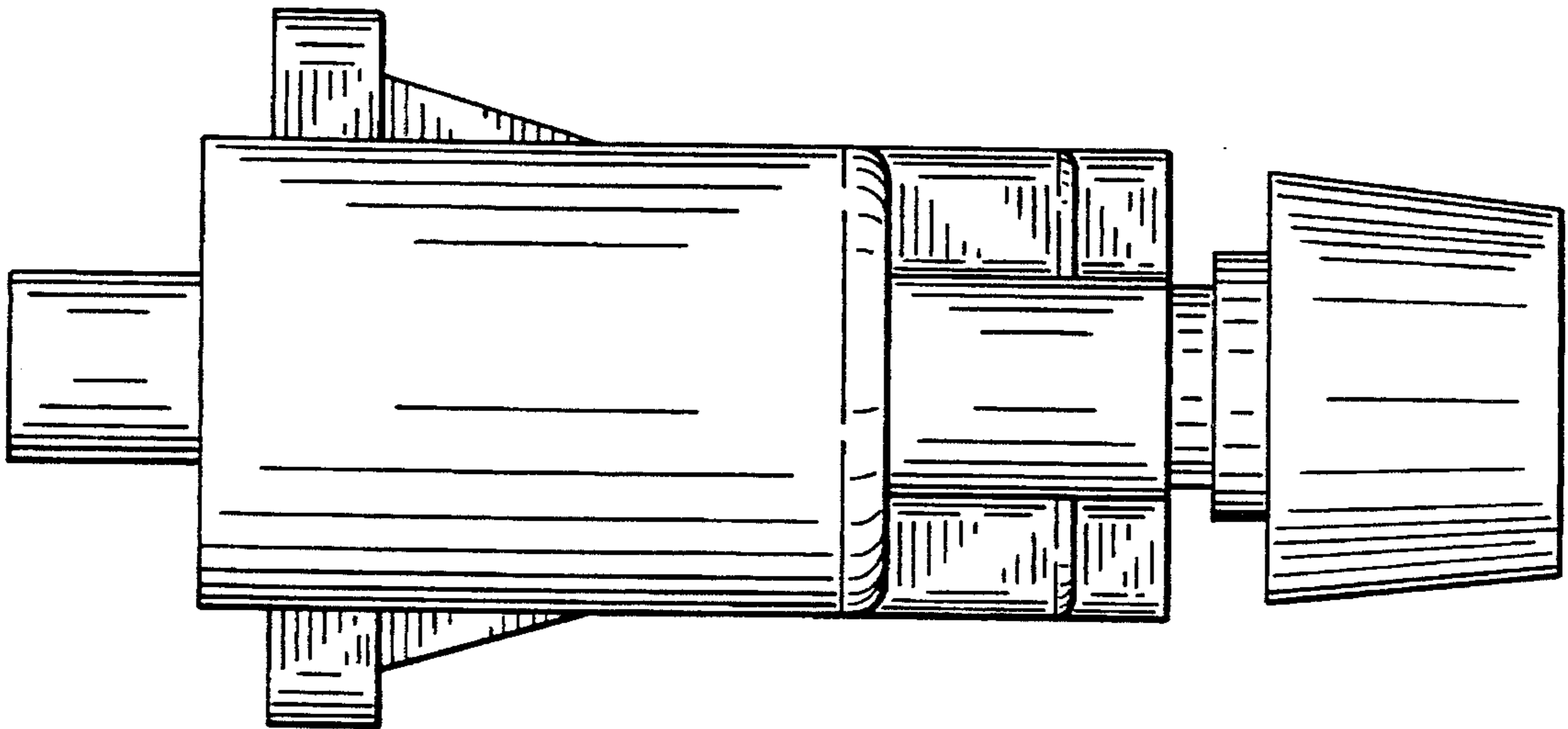

FIG. 4

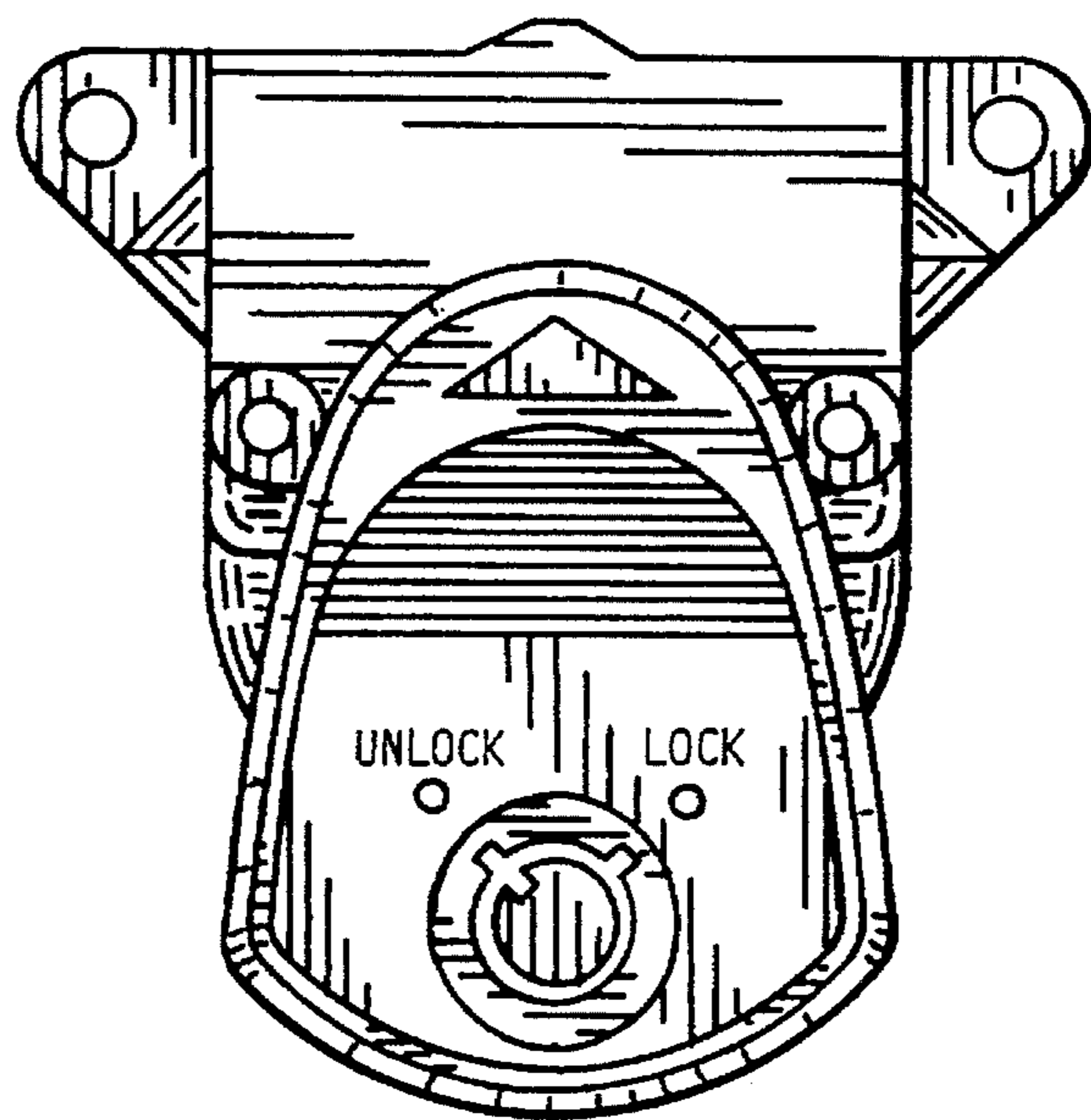

FIG. 5

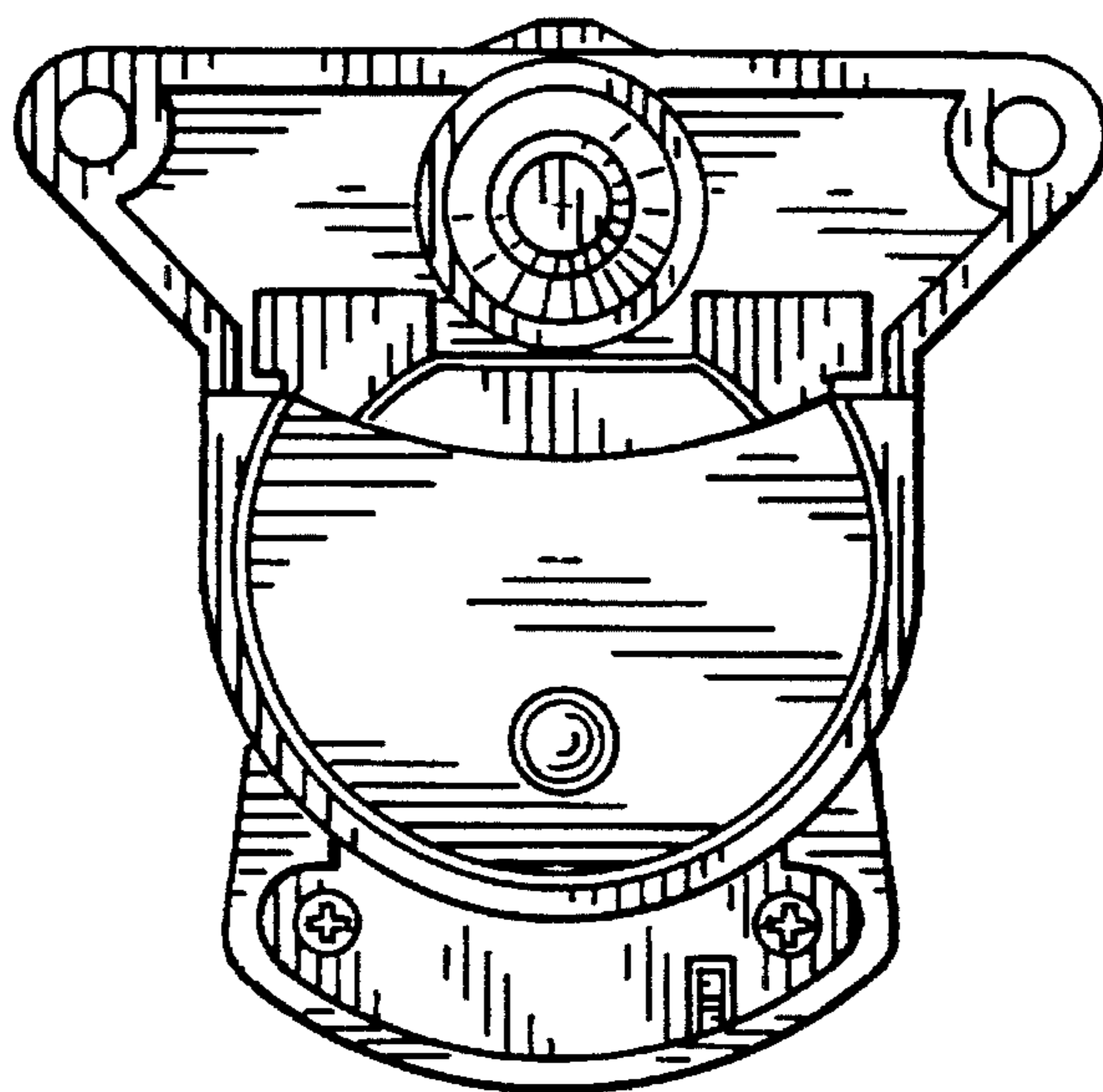

FIG. 6

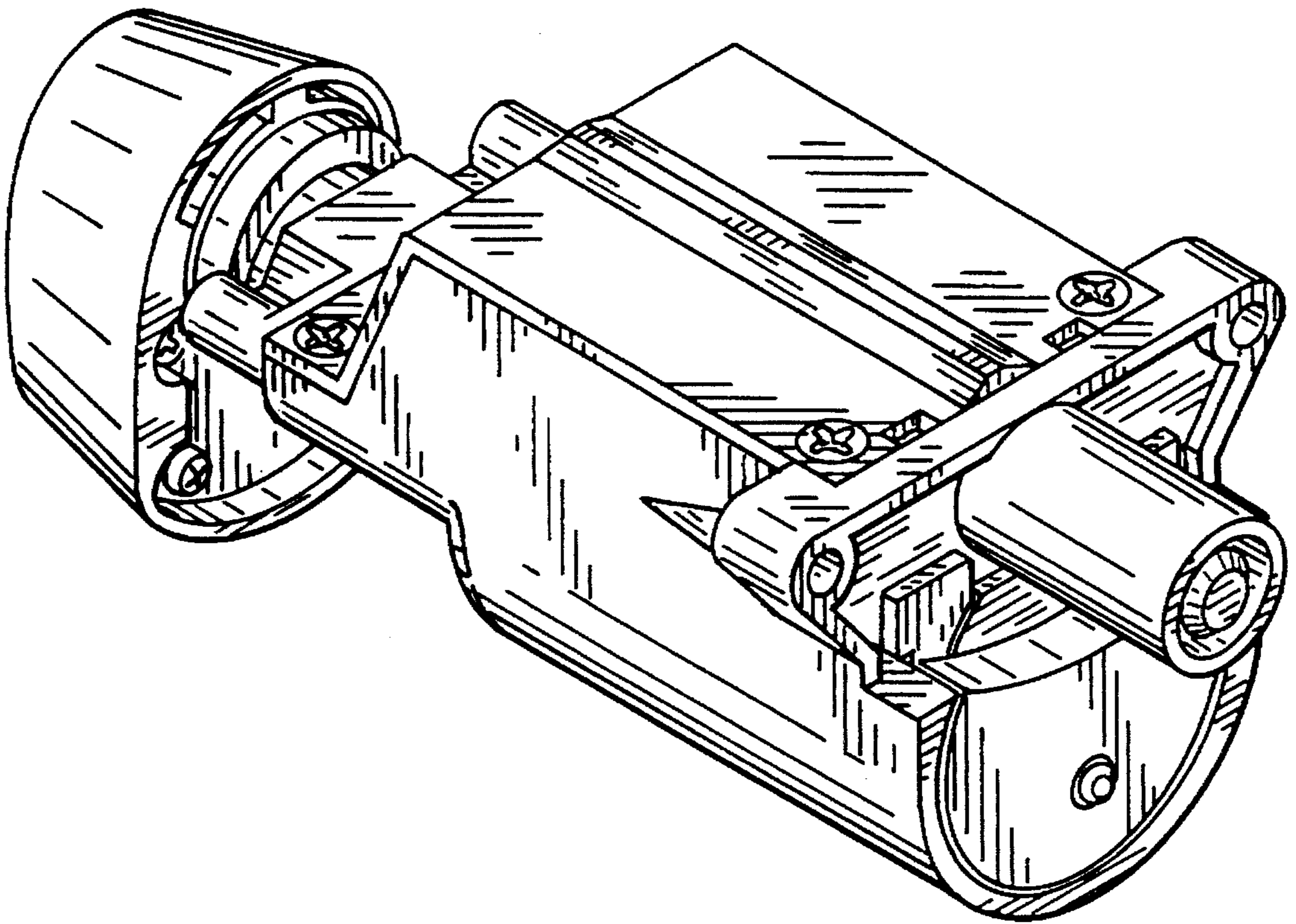

FIG. 7