



US00D368668S

United States Patent [19]

[11] Patent Number: **Des. 368,668**

Wildman et al.

[45] Date of Patent: ****Apr. 9, 1996**

[54] PNEUMATIC ACTUATOR

D. 360,677 7/1995 Ledbetter et al. D10/85
5,226,447 7/1993 Burley 340/611 X

[75] Inventors: **Craig R. Wildman**, Willoughby;
Andrew G. Stash, Chardon, both of
Ohio

Primary Examiner—Ralf Seifert
Attorney, Agent, or Firm—D. Peter Hochberg; Mark Kusner;
Michael Jaffe

[73] Assignee: **Tridelta Industries, Inc.**, Mentor, Ohio

[57] **CLAIM**

[**] Term: **14 Years**

The ornamental design for a pneumatic actuator, as shown
and described.

[21] Appl. No.: **33,386**

[22] Filed: **Jan. 11, 1995**

[52] U.S. Cl. **D10/83**

[58] Field of Search D15/7; 73/716;
D10/83, 85; 340/611

DESCRIPTION

FIG. 1 is a perspective view of a pneumatic actuator showing my new design, the broken line showing of a bracket and electric switch is for illustrative purposes only and forms no part of the claimed design;
FIG. 2 is a top plan view thereof;
FIG. 3 is a front elevational view thereof;
FIG. 4 is a rear elevational view thereof;
FIG. 5 is a right side elevational view thereof;
FIG. 6 is a left side elevational view thereof; and,
FIG. 7 is a bottom plan view thereof.

[56] References Cited

U.S. PATENT DOCUMENTS

D. 136,369	9/1943	Koppersmith	D10/85
D. 205,138	6/1966	Darrah	D10/83
D. 263,335	3/1982	Bujan	D10/85
D. 301,018	5/1989	Hestich	D10/85
D. 347,799	6/1994	Dunham et al.	D10/85

1 Claim, 3 Drawing Sheets

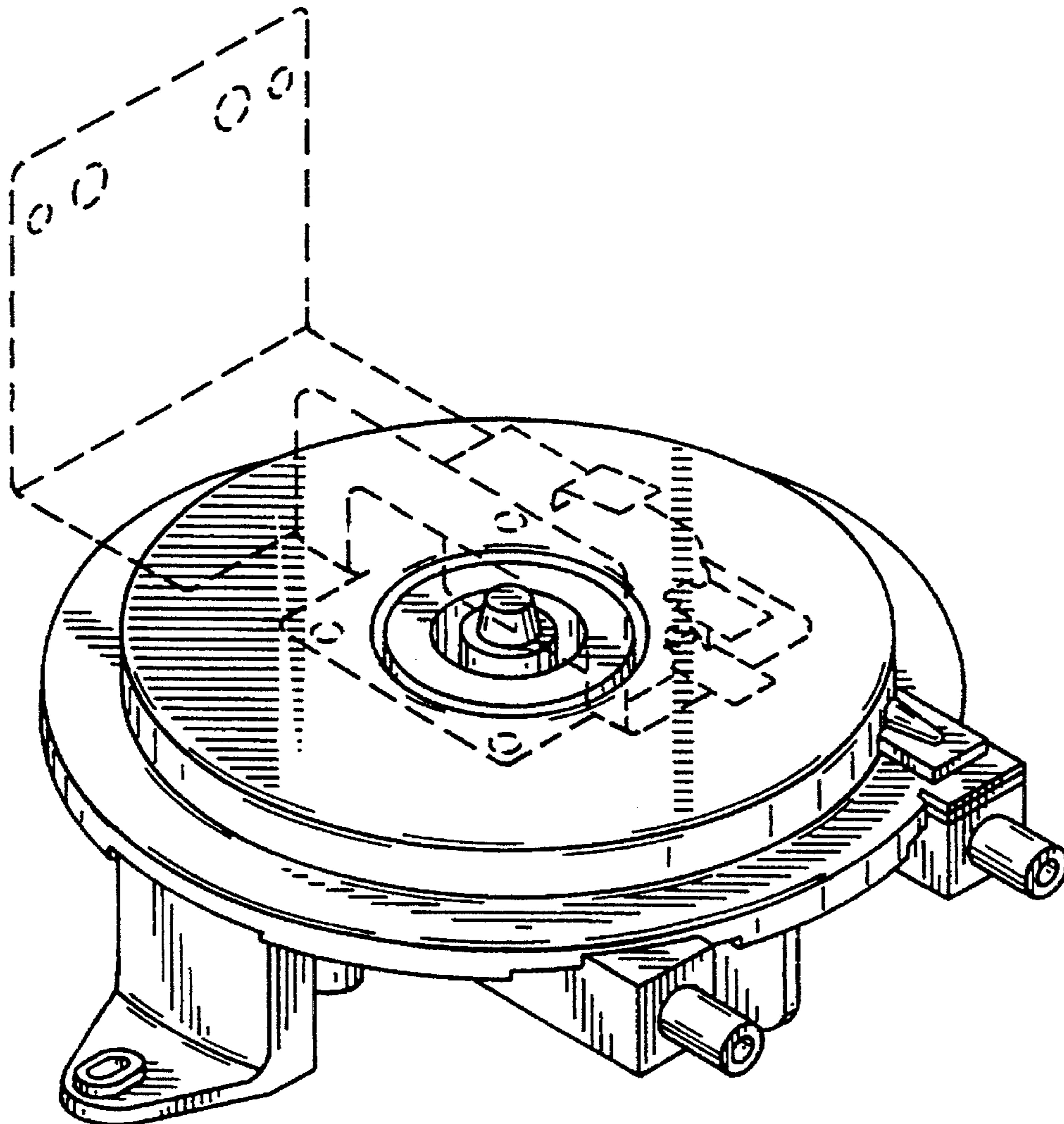

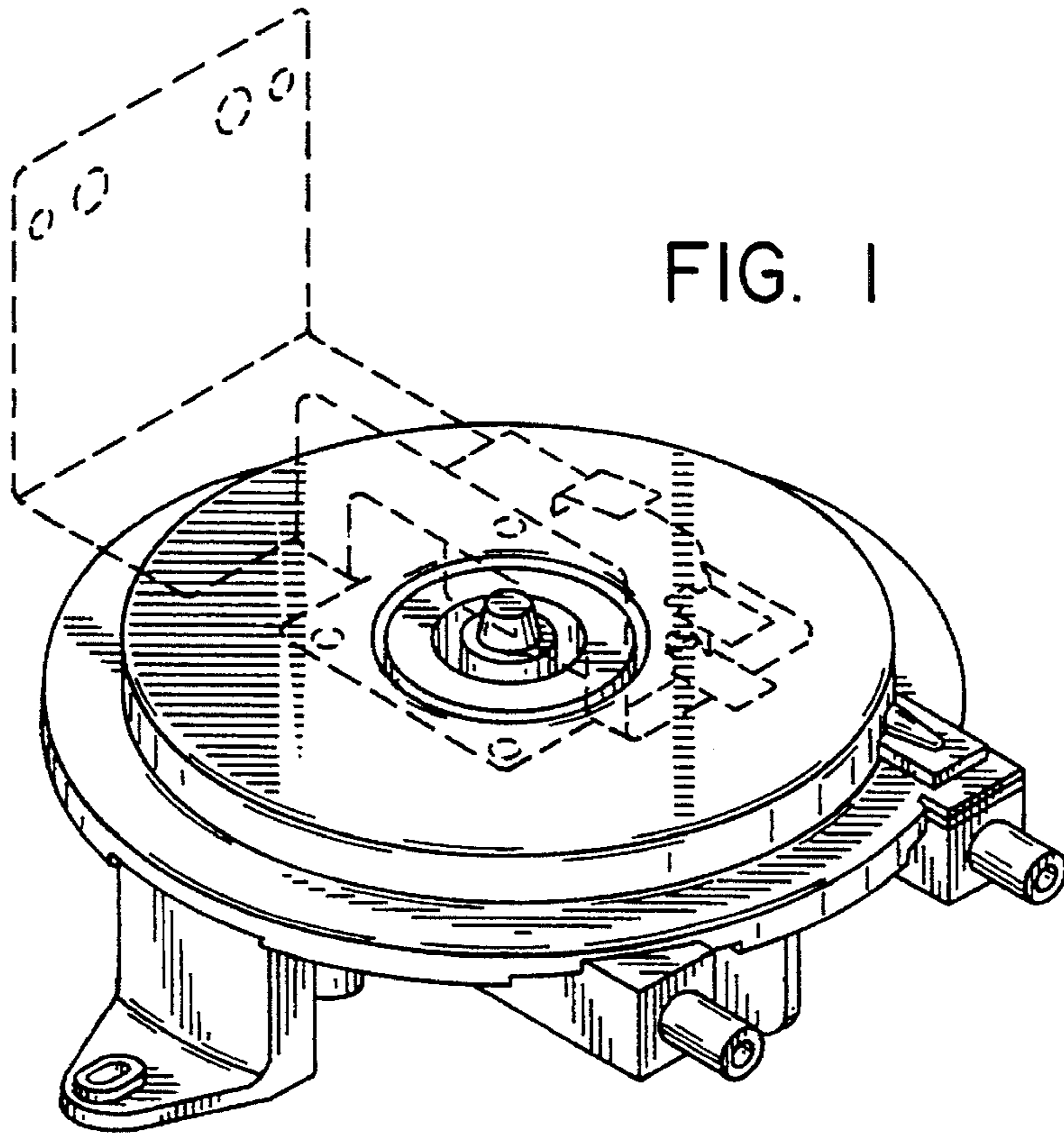

FIG. 1

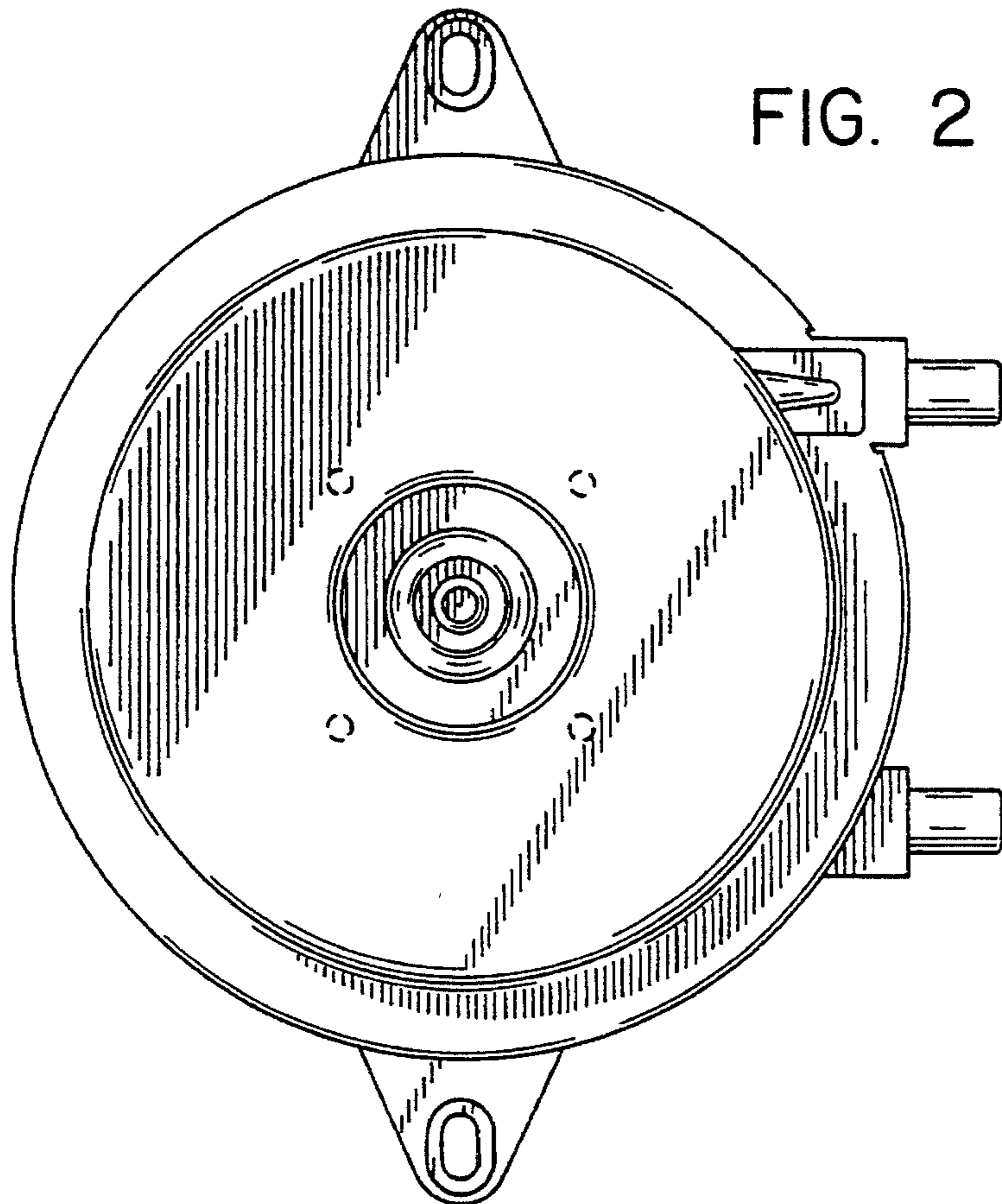

FIG. 2

FIG. 3

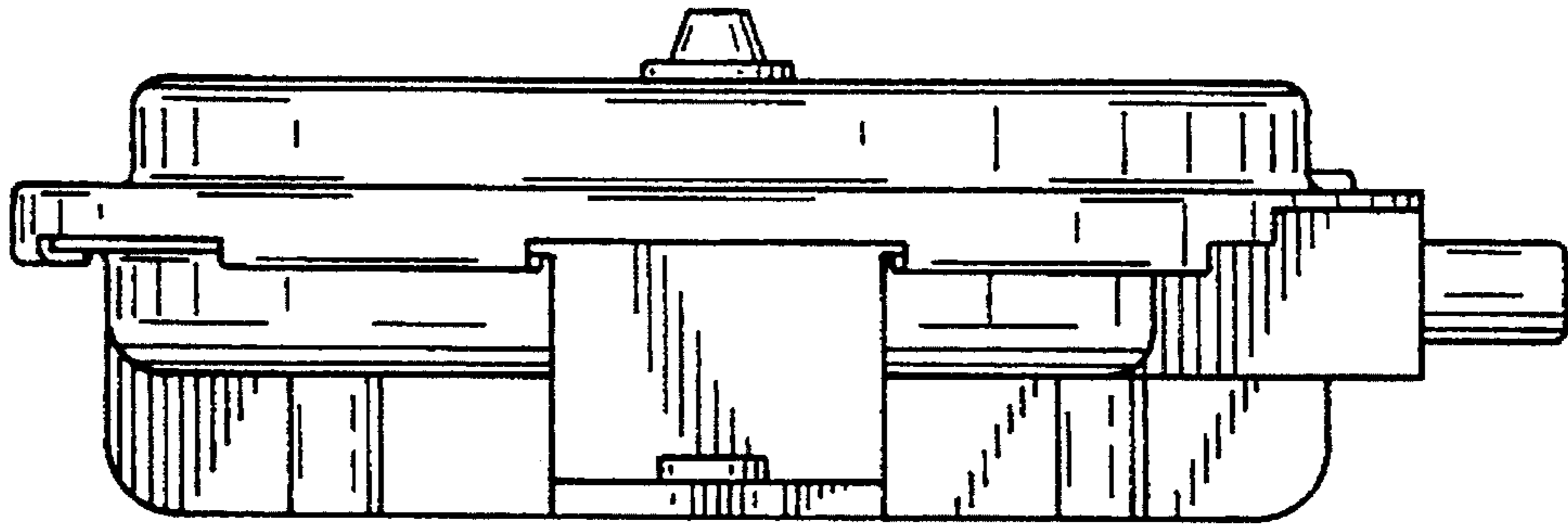

FIG. 4

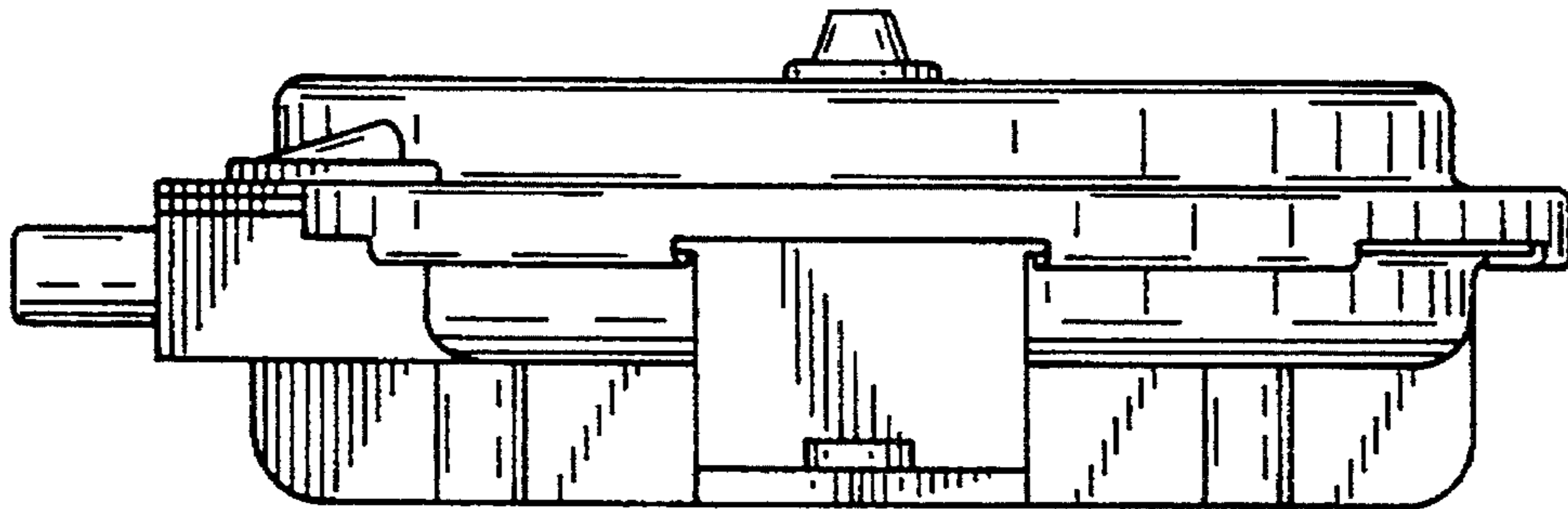

FIG. 5

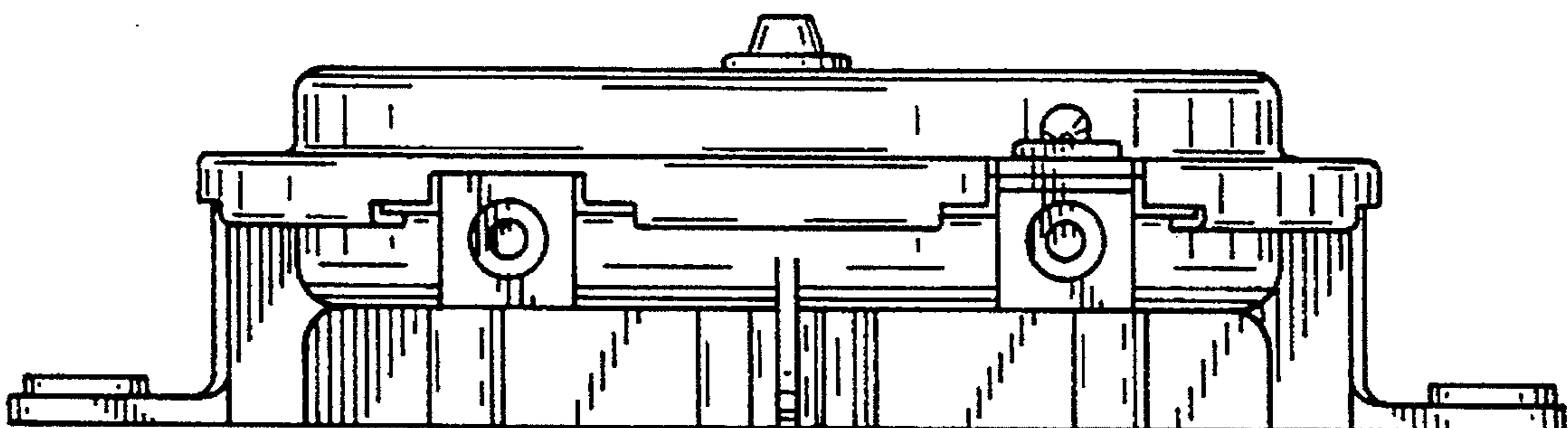

FIG. 6

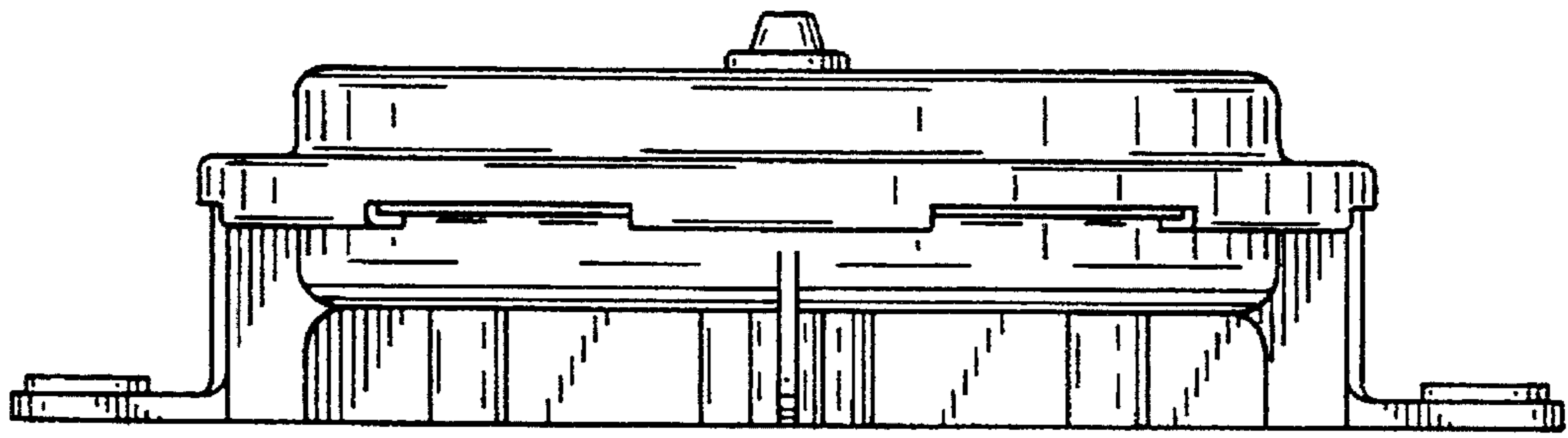

FIG. 7

