



US00D368665S

**United States Patent** [19]  
**James**

[11] **Patent Number: Des. 368,665**

[45] **Date of Patent: \*\*Apr. 9, 1996**

[54] **GAS REGULATOR**

5,103,861 4/1992 Lin ..... 137/505.46 X  
5,158,107 10/1992 Teay ..... 137/460

[75] Inventor: **Dale P. James**, Frankston, Australia

**FOREIGN PATENT DOCUMENTS**

[73] Assignee: **Ausmark International Pty. Ltd.**,  
Victoria, Australia

89815 11/1993 Australia .

[\*\*] Term: **14 Years**

*Primary Examiner*—Antoine Duval Davis  
*Attorney, Agent, or Firm*—Rothwell, Figg, Ernst & Kurz

[21] Appl. No.: **24,042**

[57] **CLAIM**

[22] Filed: **Jun. 6, 1994**

The ornamental design for a gas regulator, as shown and described.

[52] U.S. Cl. .... **D10/49; D10/96**

[58] **Field of Search** ..... D10/49, 96, 99,  
D10/103; D23/235; 137/71, 460, 490, 497,  
484.8, 505.12, 505.46, 505.42, 505.41,  
505.25, 517, 519.2, 614.19, 607, 613, 630.13,  
906; 169/58, 70; 251/358, 44, 45, 30.02,  
48, 121, 327

**DESCRIPTION**

FIG. 1 is a top plan view of a gas regulator housing;  
FIG. 2 is a side view of the gas regulator housing;  
FIG. 3 is an underneath plan view of the gas regulator housing;  
FIG. 4 is an end view of the gas regulator housing;  
FIG. 5 is a perspective view from above of the gas regulator housing; and,  
FIG. 6 is a perspective view from below of the gas regulator housing.

[56] **References Cited**

**U.S. PATENT DOCUMENTS**

D. 27,697 9/1897 Bassett ..... D10/99  
D. 235,443 6/1975 Johnson et al. .... D23/235

**1 Claim, 2 Drawing Sheets**

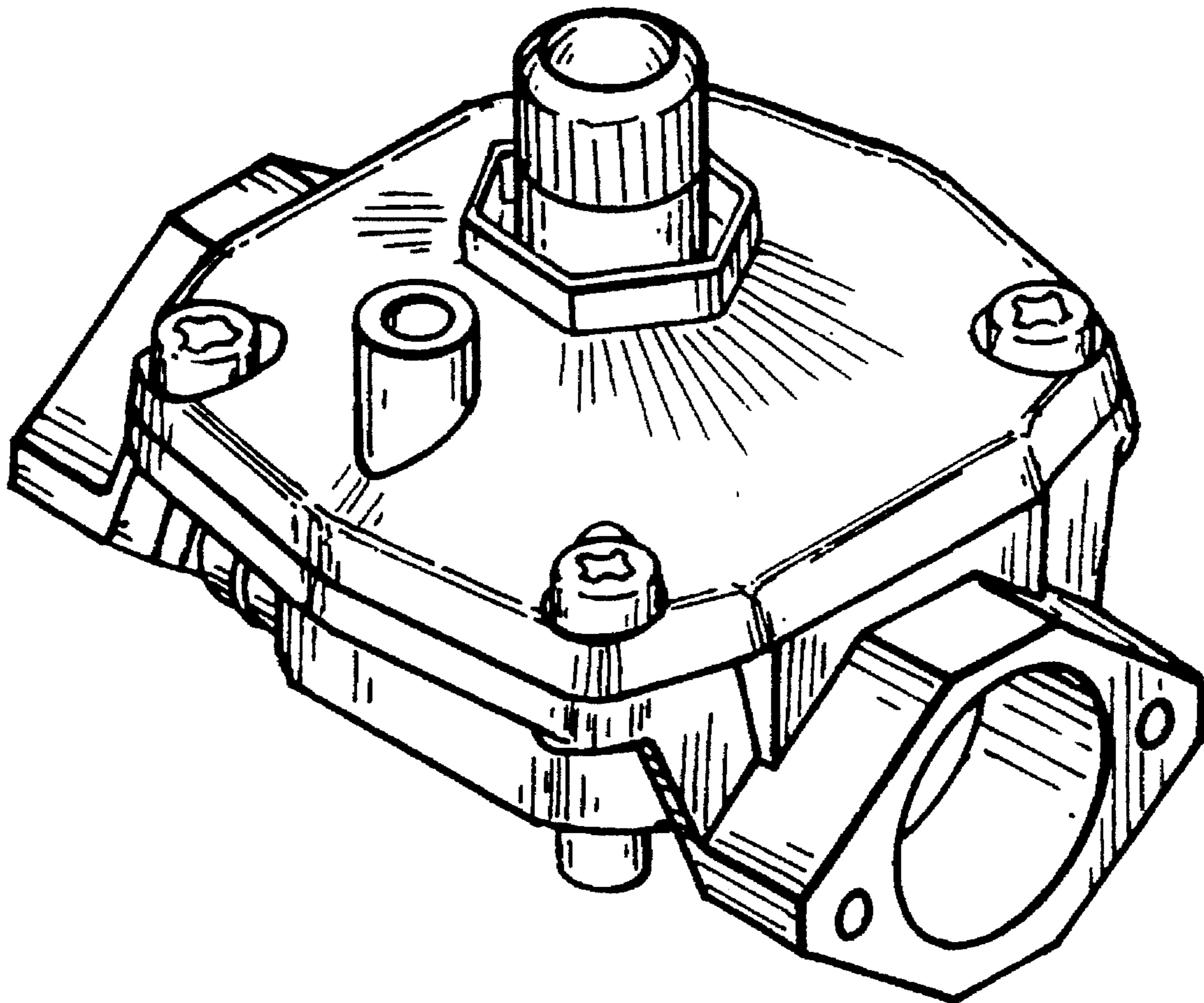

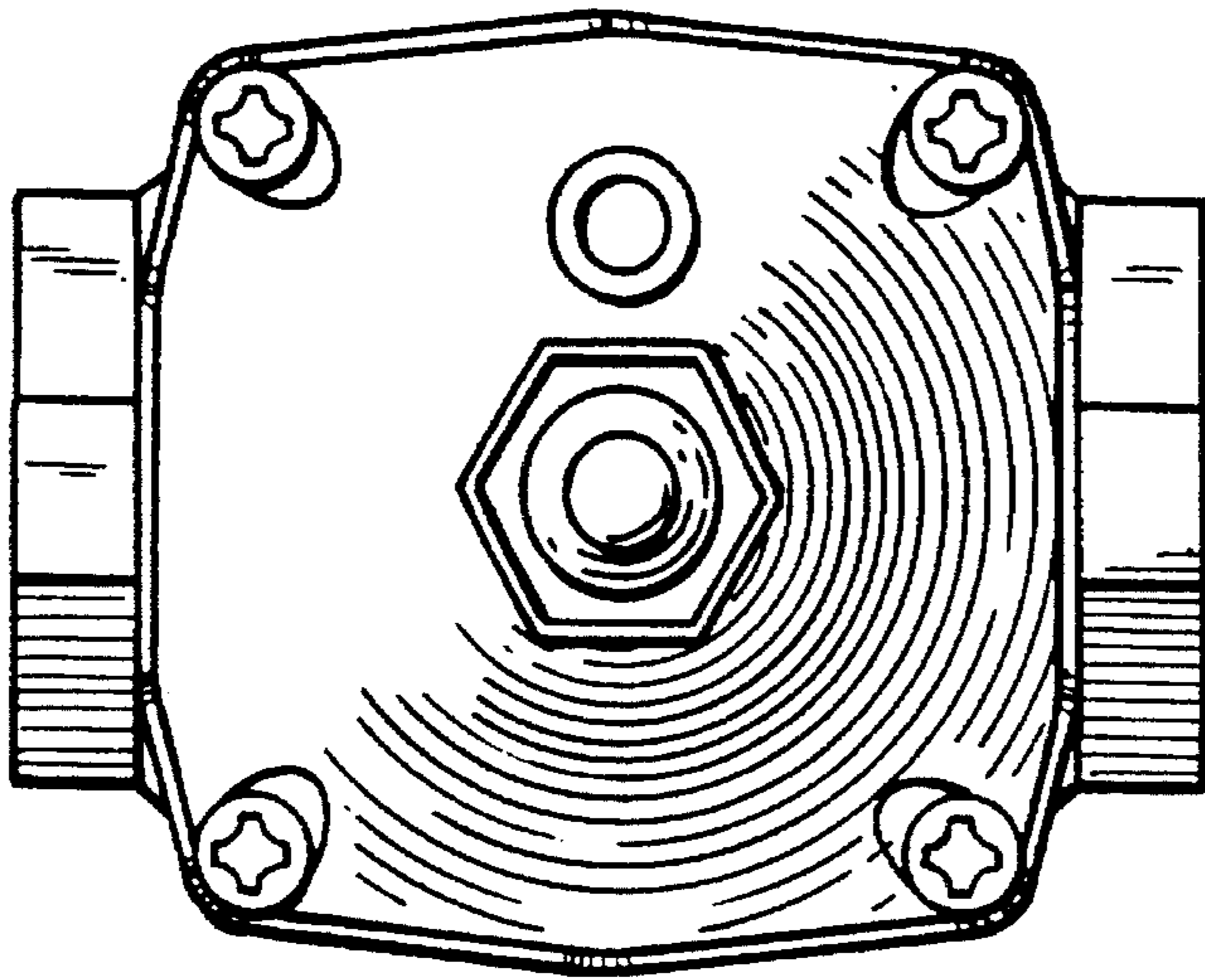

FIG. 1.

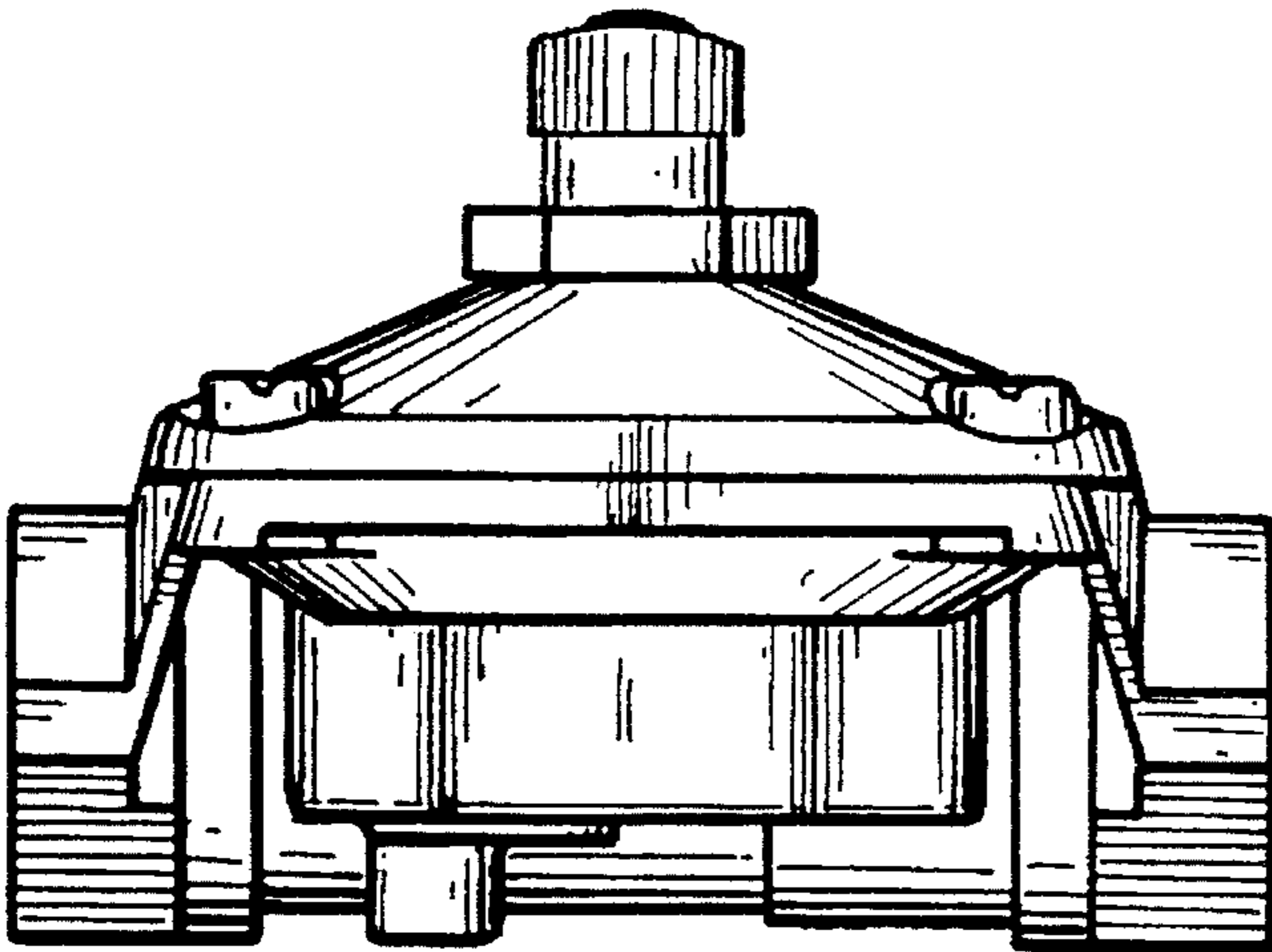

FIG. 2.

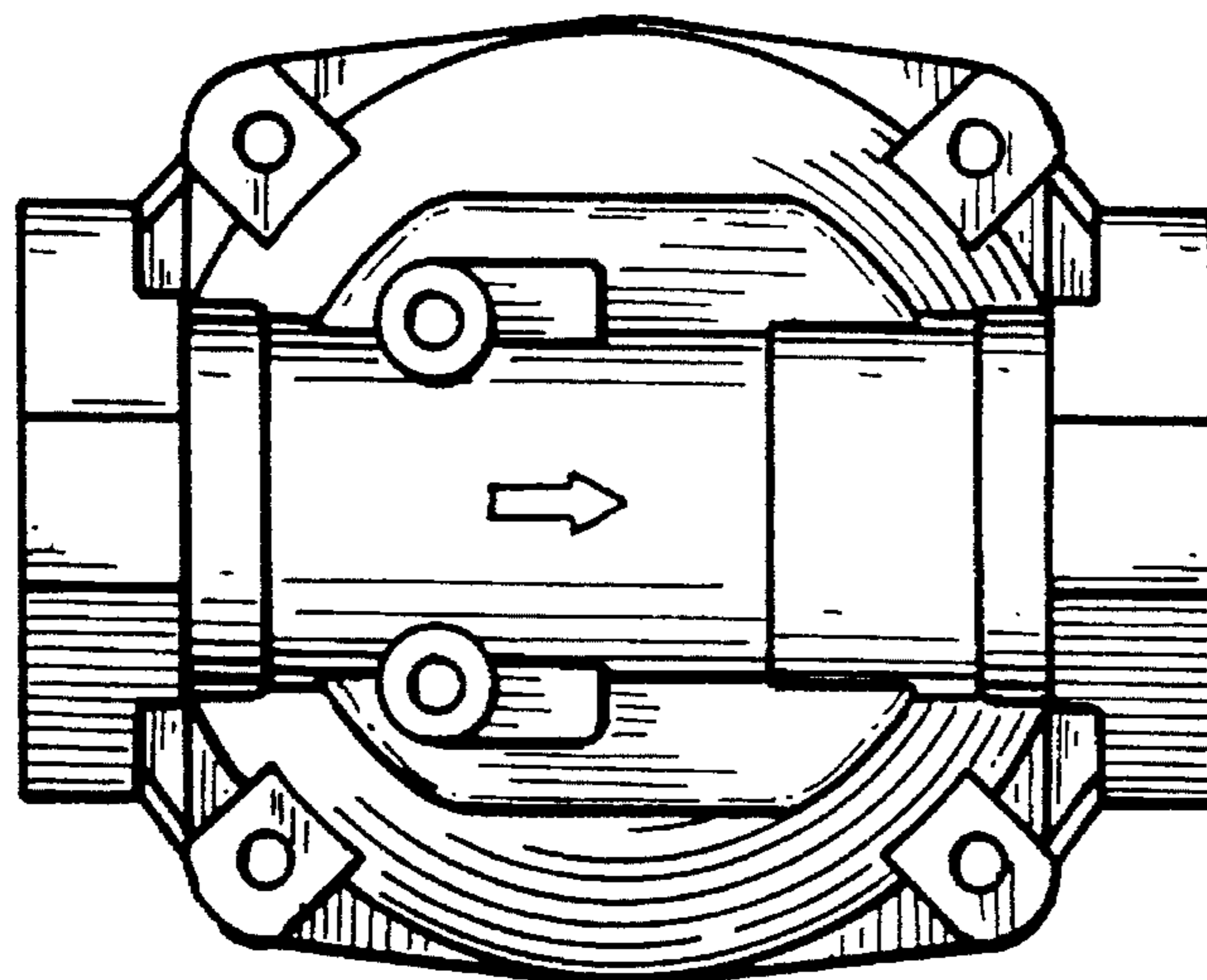

FIG. 3.

FIG. 4.

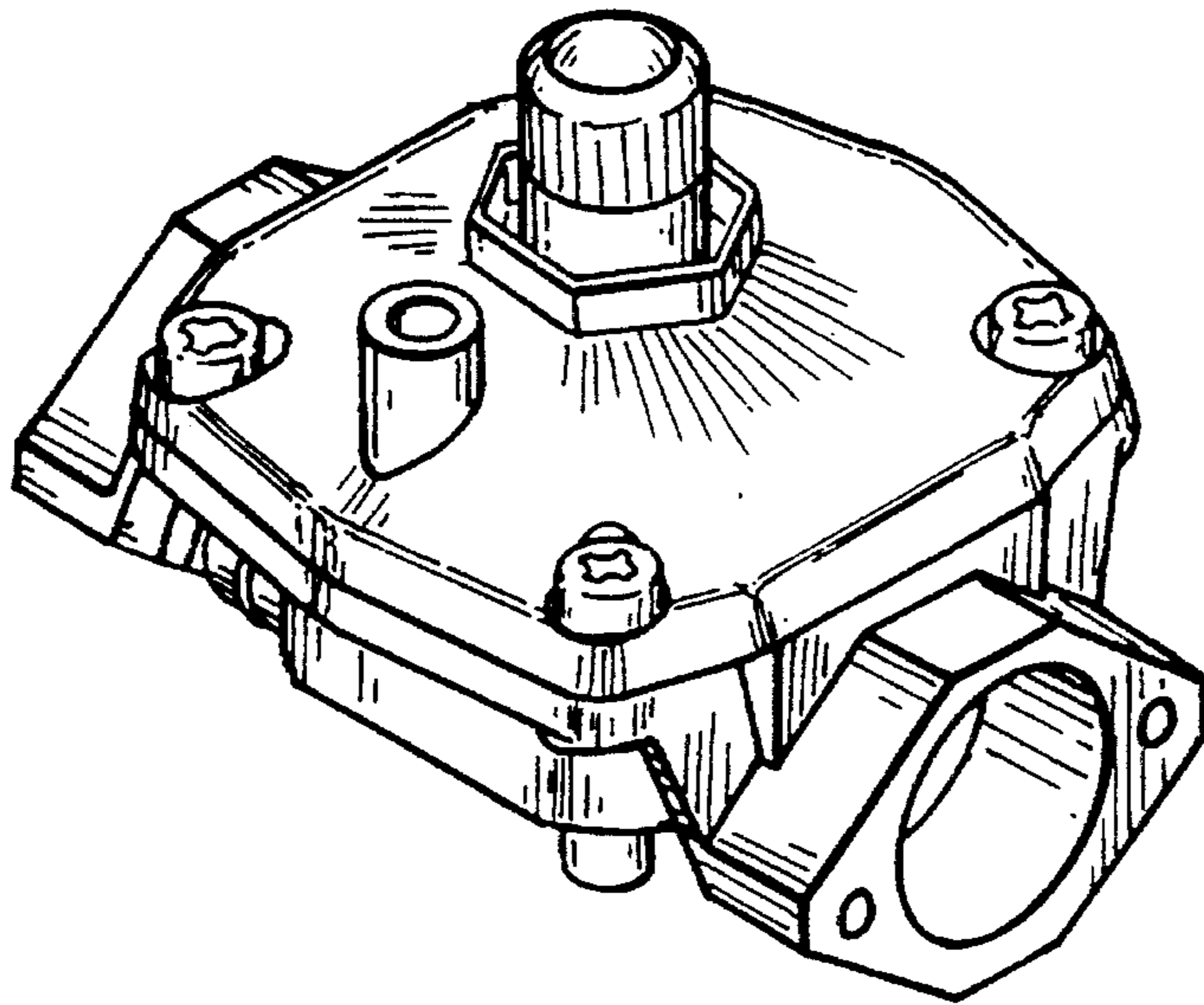
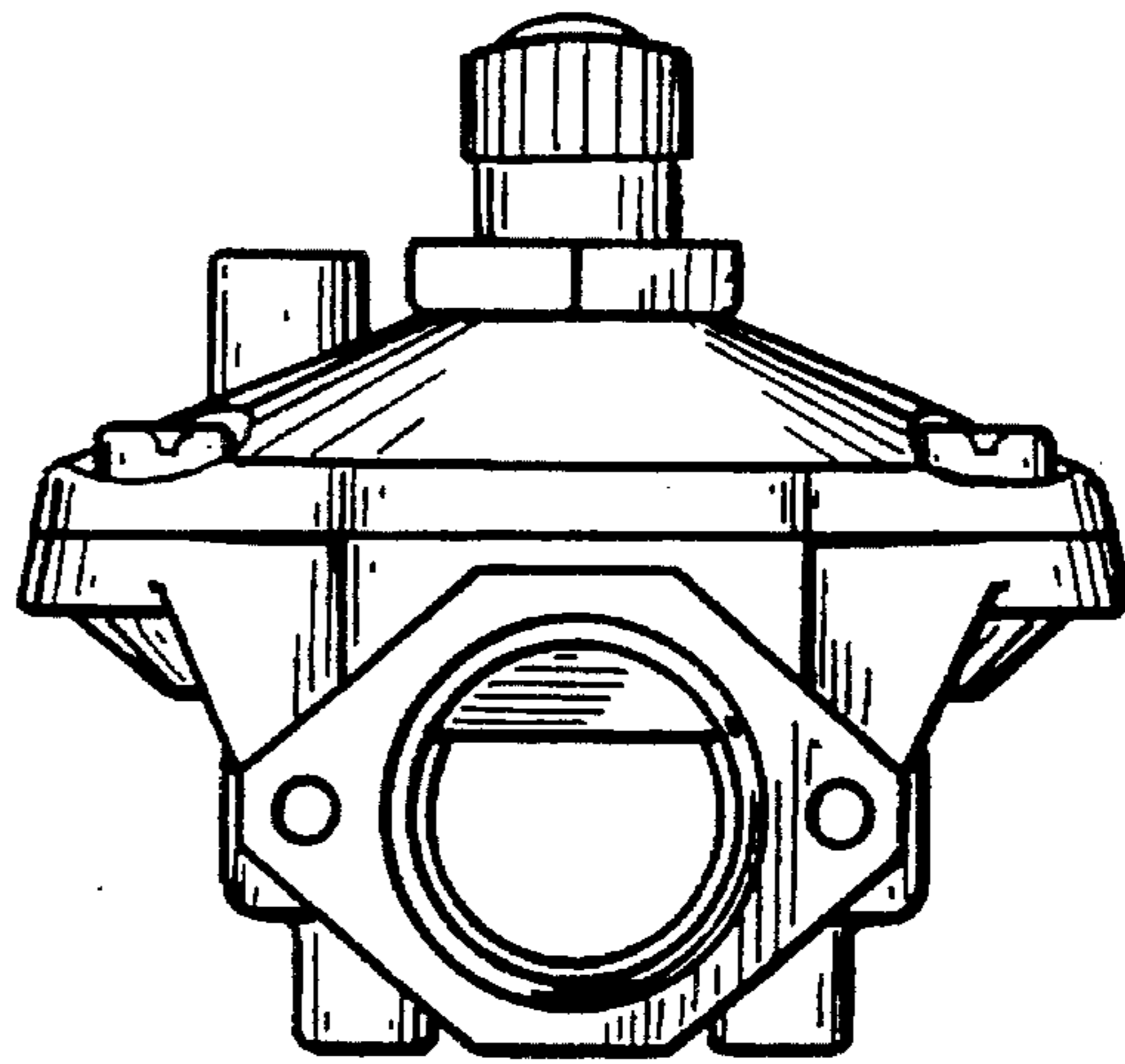

FIG. 5.

FIG. 6.

