



US00D368598S

United States Patent [19]

Natuzzi et al.

[11] Patent Number: **Des. 368,598**

[45] Date of Patent: ****Apr. 9, 1996**

[54] SEAT

[75] Inventors: **Pasquale Natuzzi**, Santeramo In Colle;
Arcangelo Scarati, Talsano, both of Italy

[73] Assignee: **Industrie Natuzzi, Spa**, Bari, Italy

[**] Term: **14 Years**

[21] Appl. No.: **33,404**

[22] Filed: **Jan. 12, 1995**

Related U.S. Application Data

[63] Continuation-in-part of Ser. No. 16,415, Dec. 14, 1993, Pat. No. Des. 355,309.

[52] U.S. Cl. **D6/381**; D6/334

[58] Field of Search D6/334, 335, 364, D6/371, 373, 381, 500, 501, 502; 297/232, 445, 446

[56] References Cited

U.S. PATENT DOCUMENTS

D. 355,309 2/1995 Natuzzi et al. D6/381

OTHER PUBLICATIONS

Chairs and Couches by Curtis, ©1977, p. 80, Victorian Settee third down from top on left.

R. Jones, sofa shown.

Bloomingdale's, Sep. 24, 1994, front cover, "Alcantara" sofa and chair by Natuzzi.

Natuzzi Model 172, Apr. 1986 at International Home Furnishings Market in High Point, North Carolina.

Natuzzi Model 446, Apr. 1988 at International Home Furnishings Market in High Point, North Carolina.

Natuzzi Model 616/617, Oct. 1988 at International Home Furnishings Market in High Point, North Carolina.

Natuzzi Model 768, Apr. 1990 at International Home Furnishings Market in High Point, North Carolina.

Natuzzi Model 811, Oct. 1990 at International Home Fur-

nishings Market in High Point, North Carolina. Natuzzi Model 832, Apr. 1991 at International Home Furnishings Market in High Point, North Carolina. Natuzzi Model 848, Apr. 1991 at International Home Furnishings Market in High Point, North Carolina. Natuzzi Model 851, Apr. 1991 at International Home Furnishings Market in High Point, North Carolina. Natuzzi Model 905, Apr. 1992 at International Home Furnishings Market in High Point, North Carolina. Natuzzi Model 915, Apr. 1992 at International Home Furnishings Market in High Point, North Carolina. Waynline, Jan. 1982, Sofa #660/810 at left. Marshall Field's, p. 7, sofa #4 at bottom right. Interiors, Apr. 1991, p. 69, sofa in background of bottom left frame.

Primary Examiner—Gary D. Watson

Attorney, Agent, or Firm—Bell, Seltzer, Park & Gibson

[57] CLAIM

The ornamental design for a seat, as shown and described.

DESCRIPTION

FIG. 1 is a right side perspective view of a seat showing our new design in the form of a sofa;

FIG. 2 is a front elevational view thereof;

FIG. 3 is a left side elevational view, the right side being a mirror image thereof;

FIG. 4 is a rear left side perspective view thereof;

FIG. 5 is a top perspective view thereof;

FIG. 6 is a right side perspective view of a seat showing our new design in the form of a love seat;

FIG. 7 is a front elevational view thereof;

FIG. 8 is a left side perspective view of a seat showing our new design in the form of a chair; and,

FIG. 9 is a front elevational view thereof.

The portions shown in broken lines, representing stitching on the side and end panels and leg members, in the drawings form no portion of the design being claimed.

1 Claim, 2 Drawing Sheets

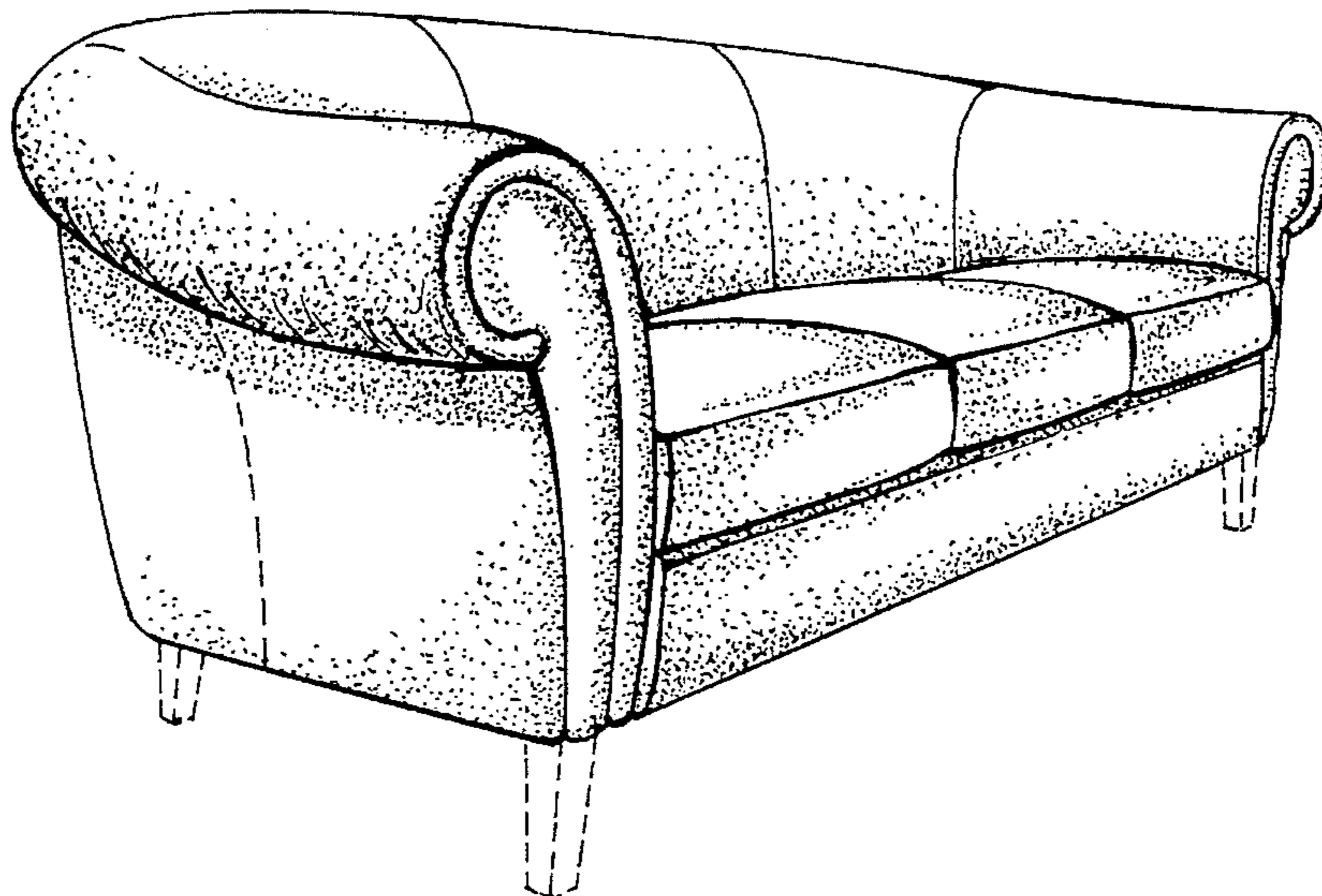

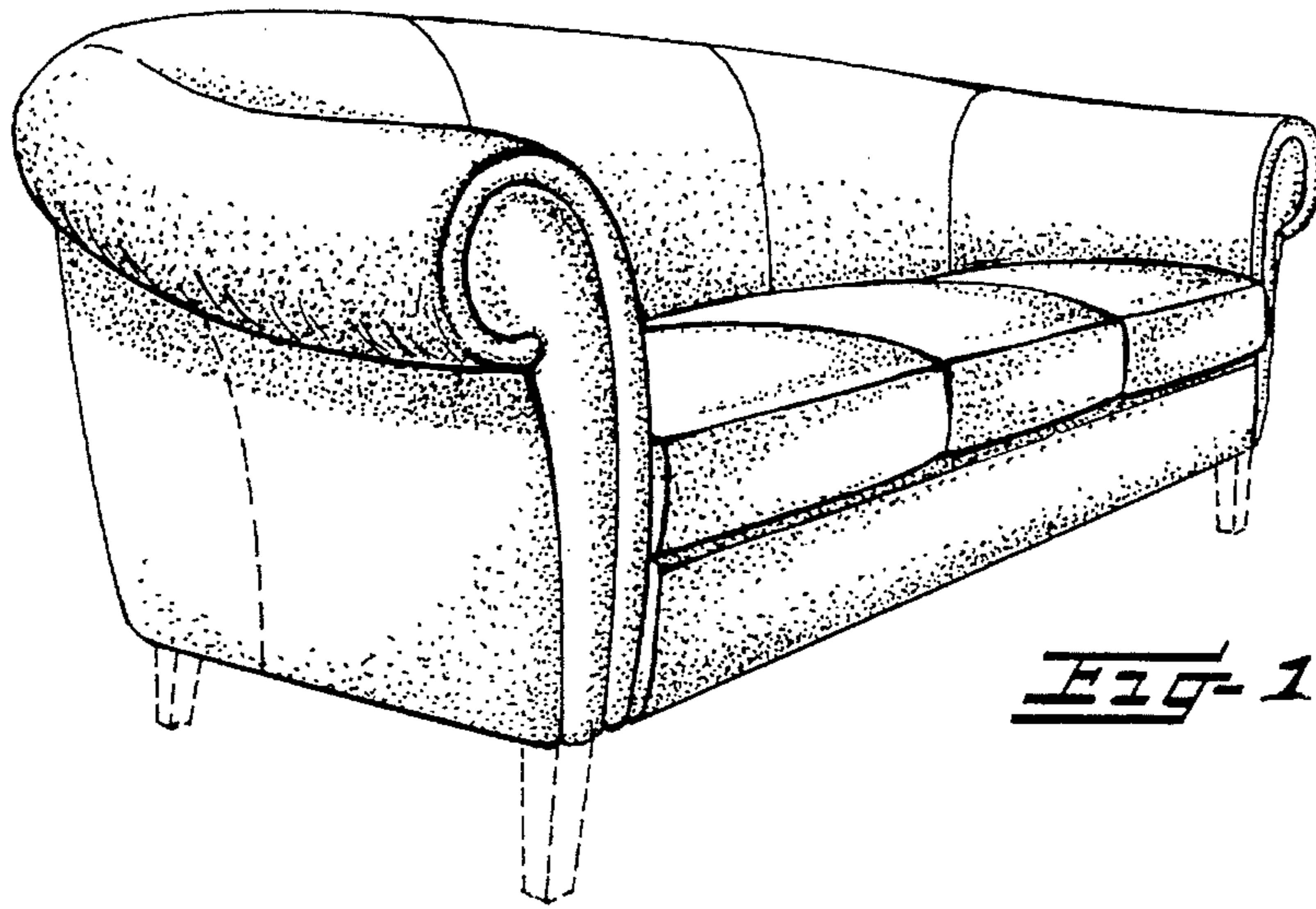

FIG-1

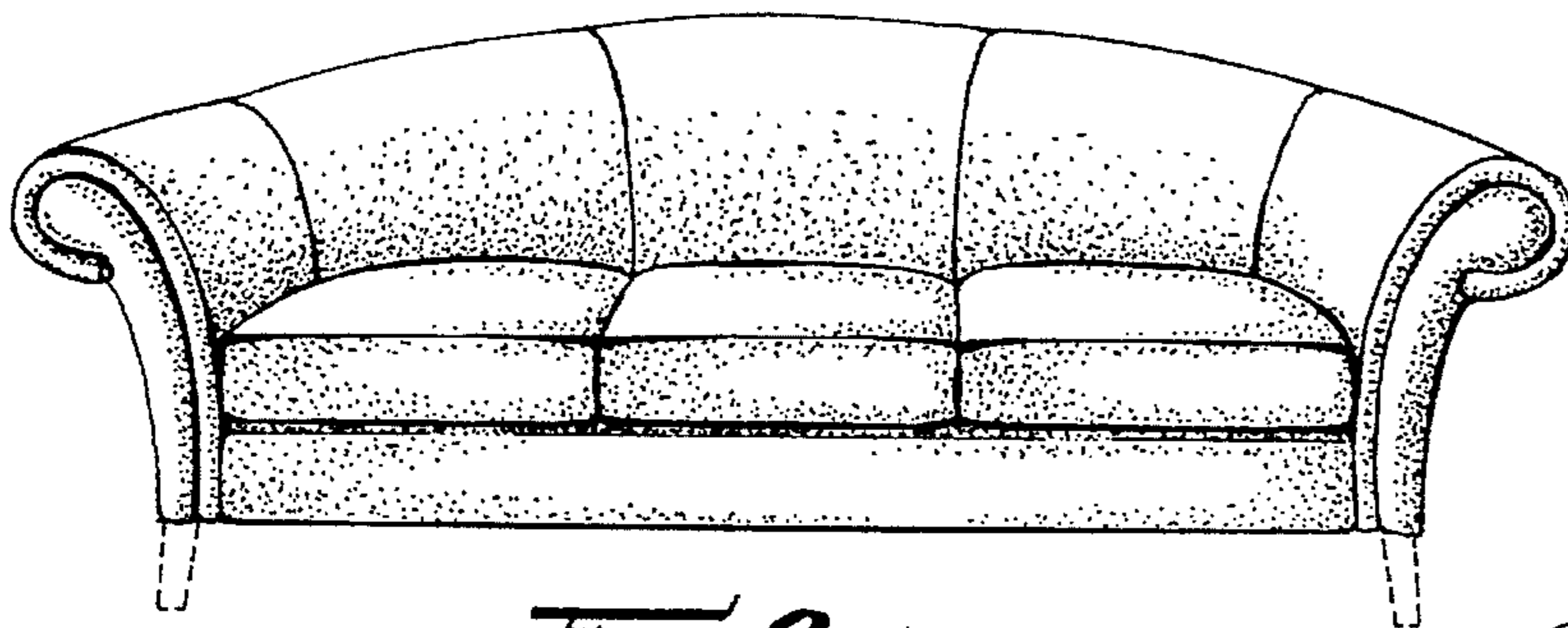

FIG-2

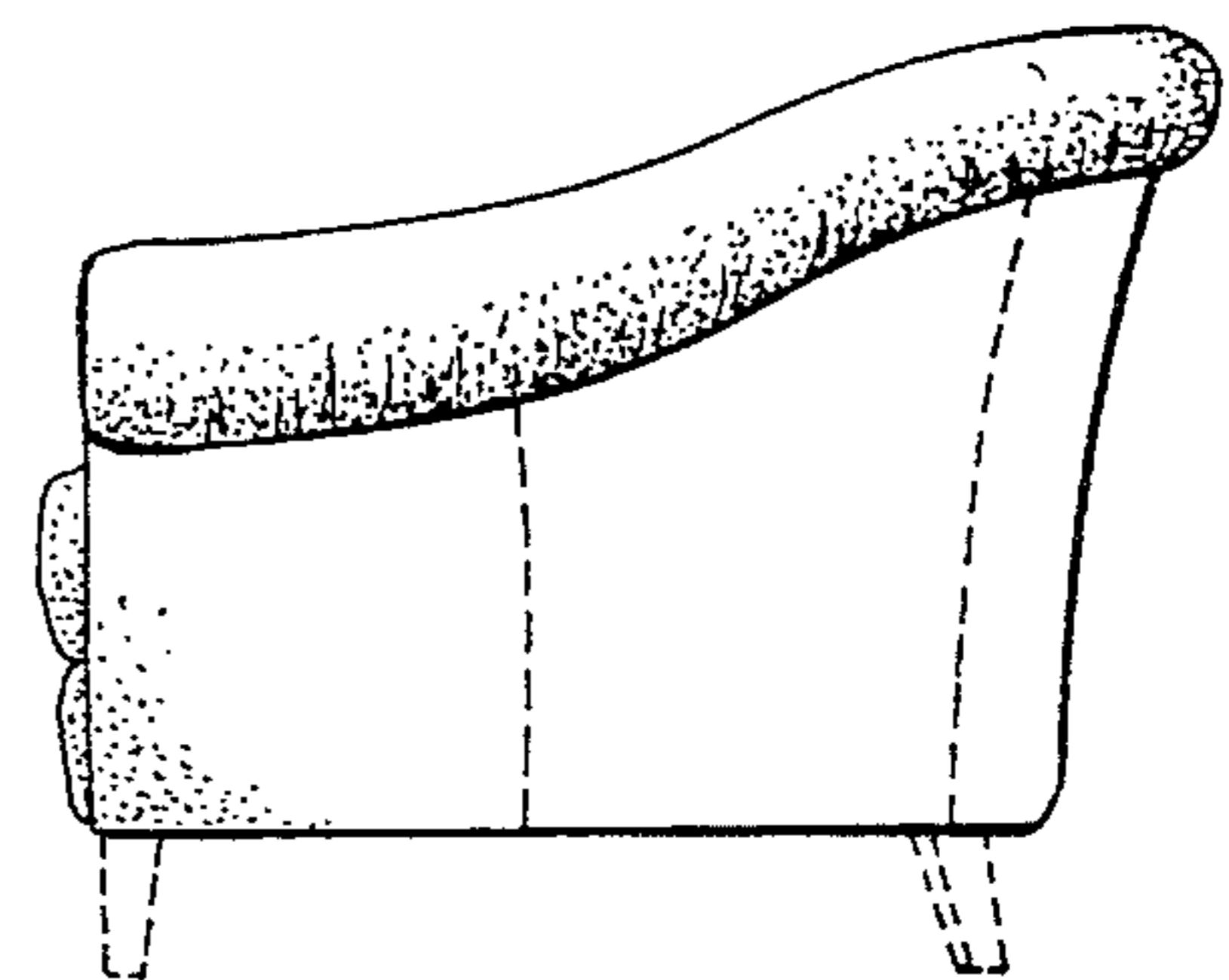

FIG-3

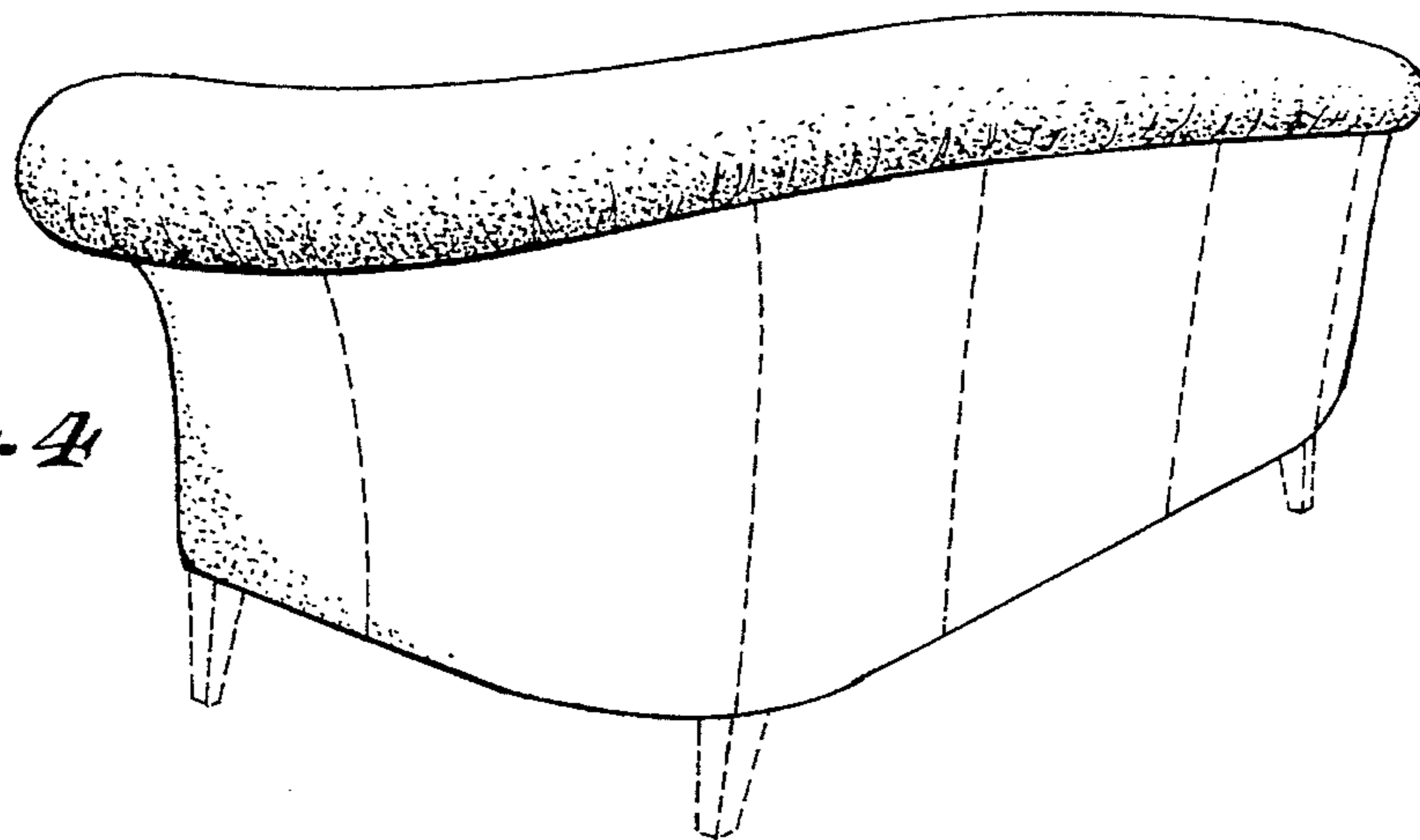

FIG-4

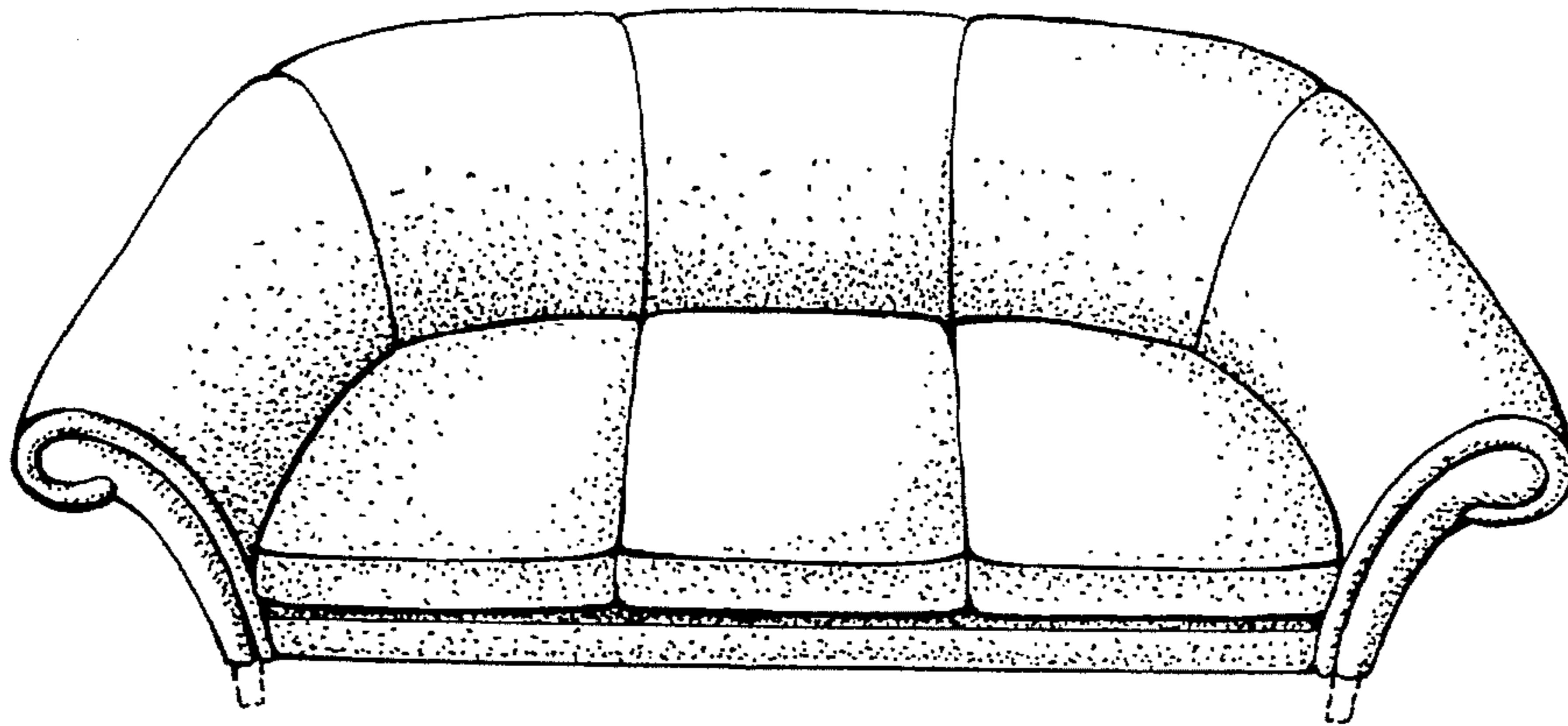

FIG-5

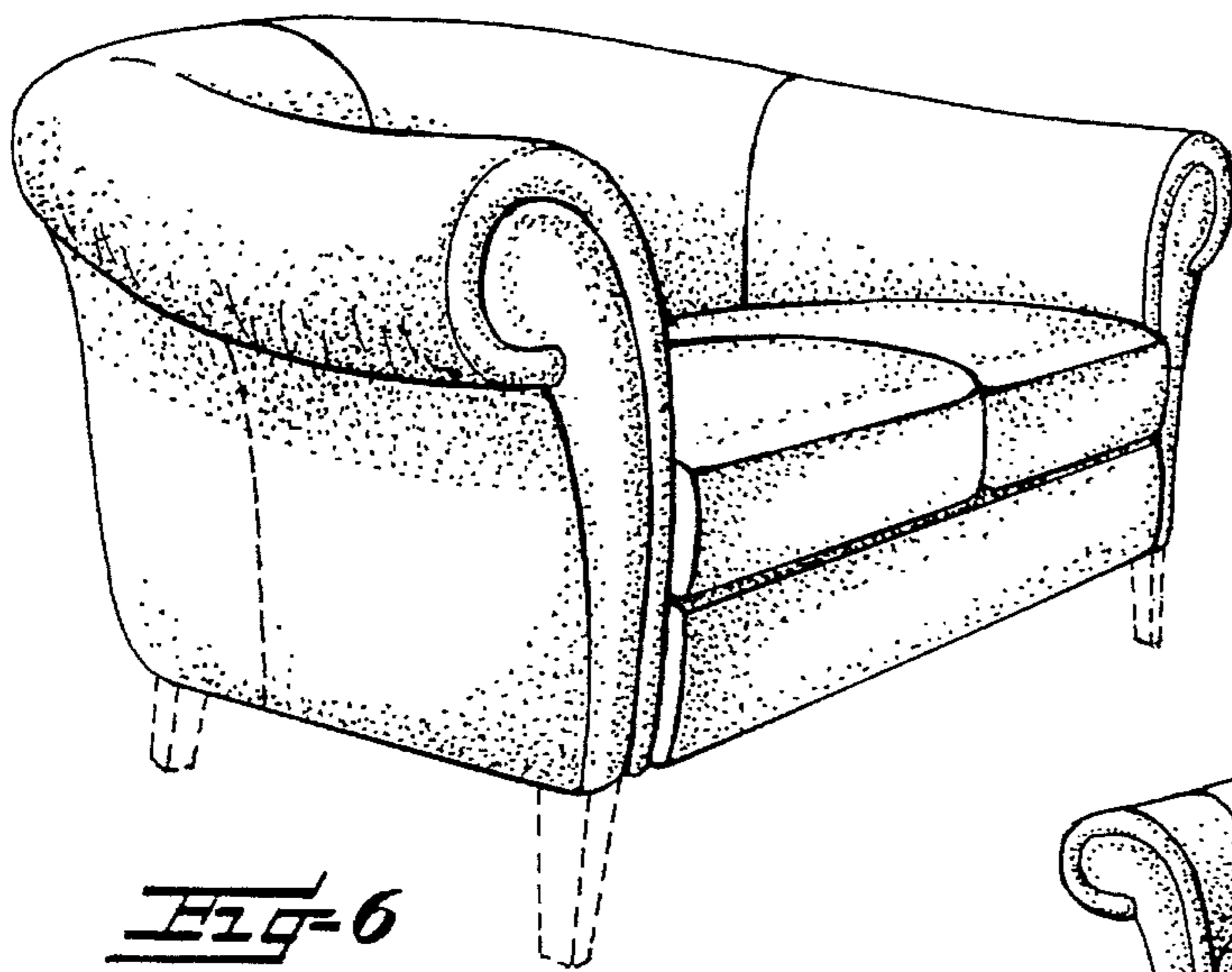

FIG-6

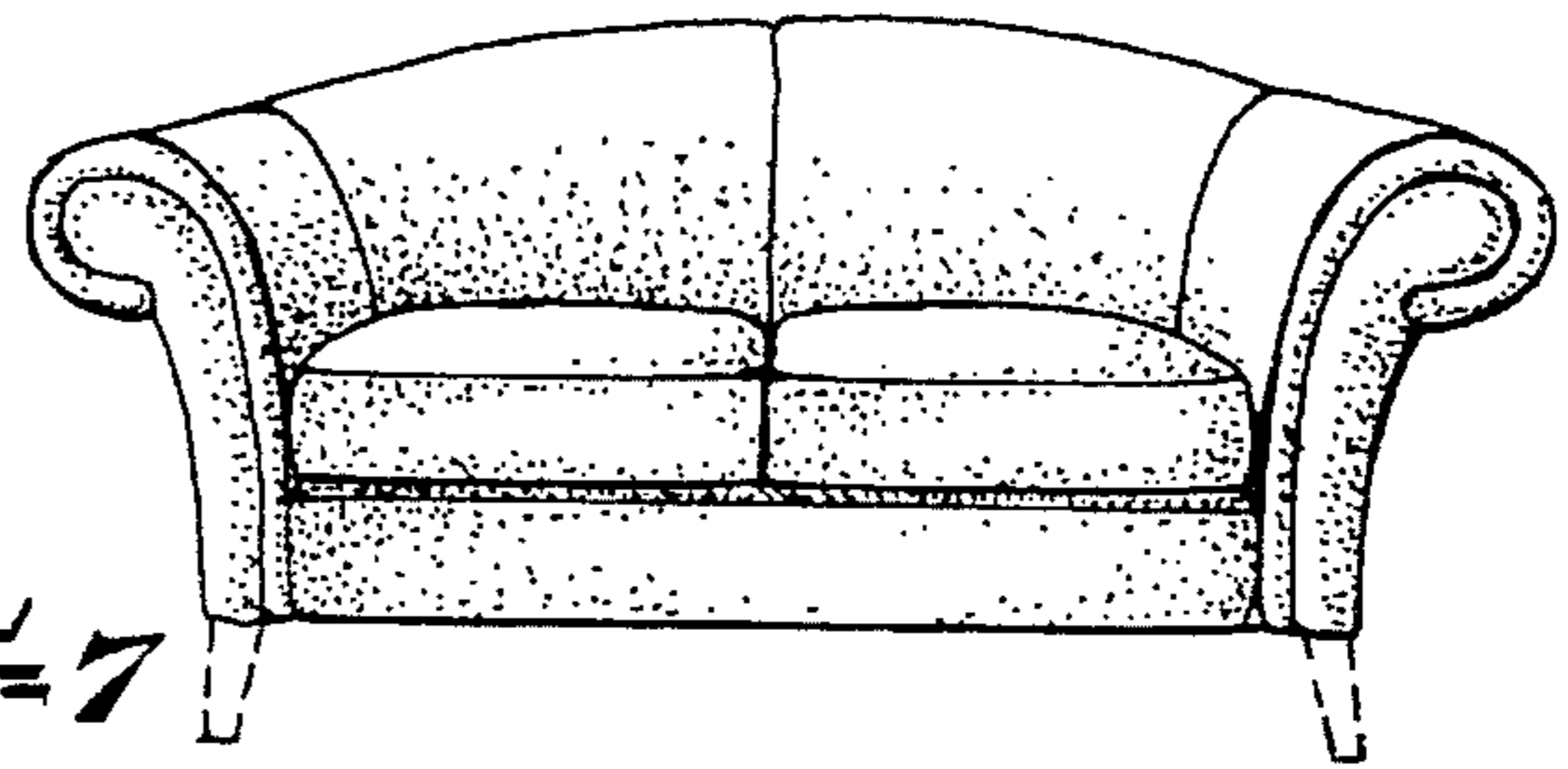

FIG-7

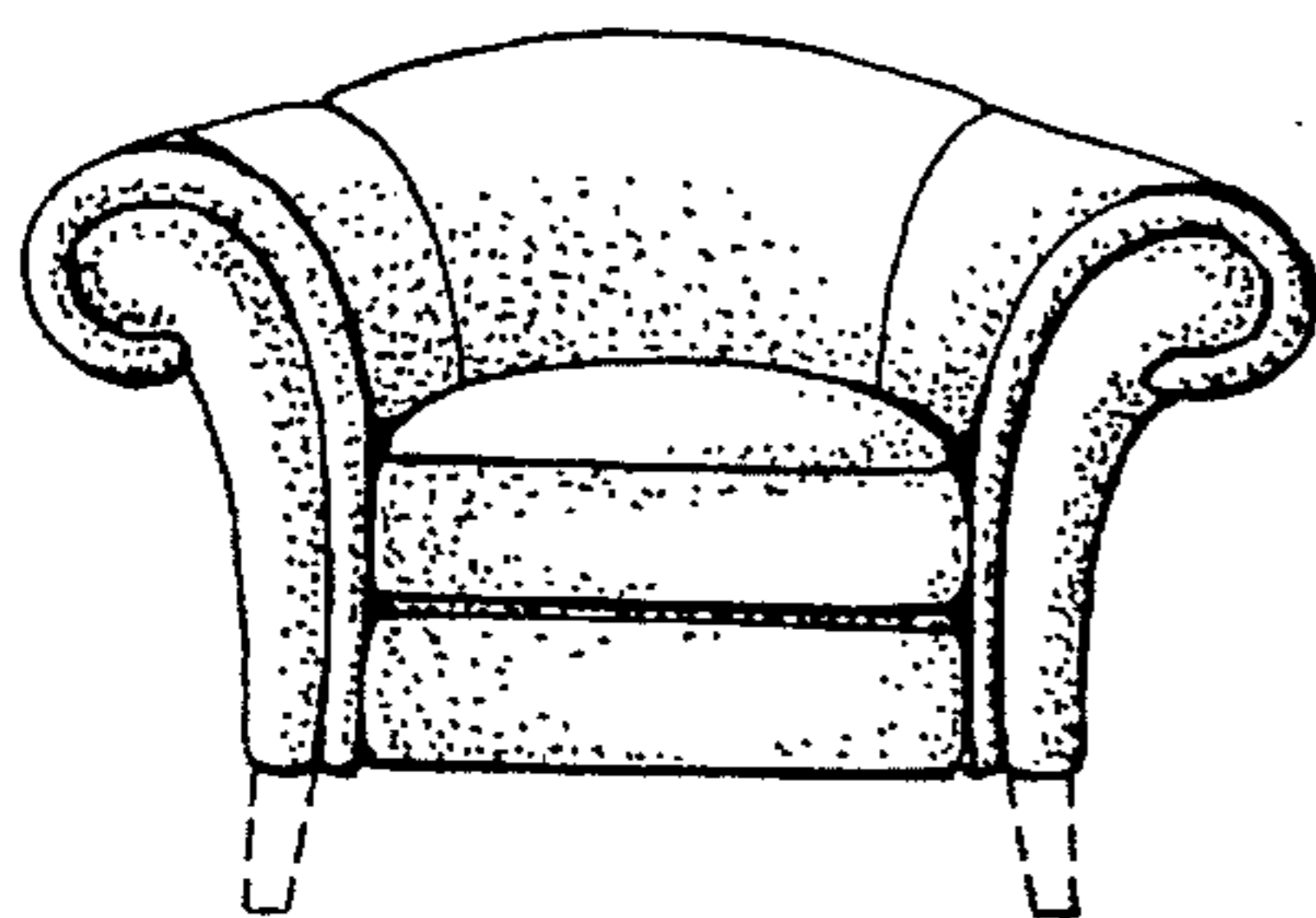

FIG-9

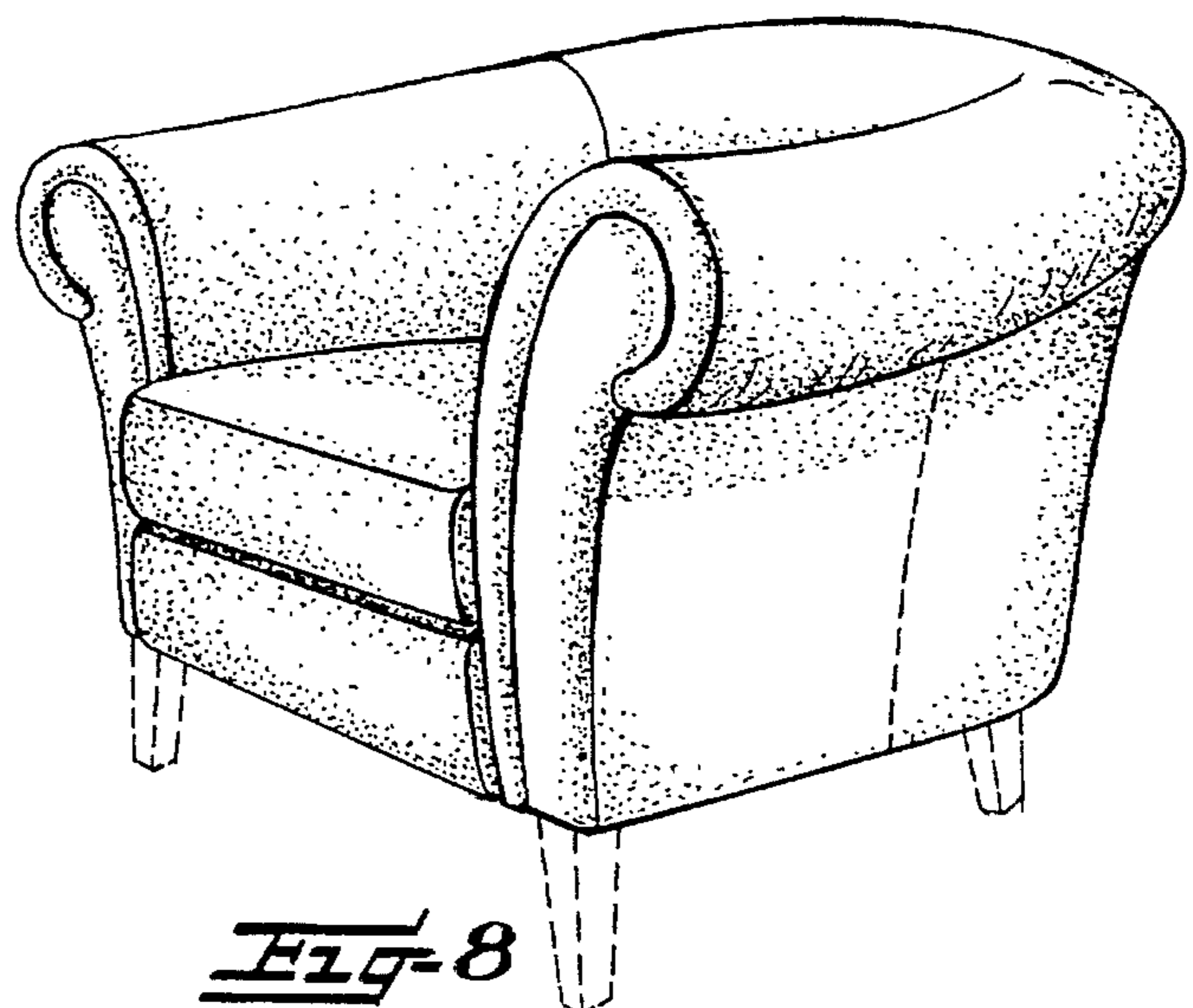

FIG-8