



US00D368448S

United States Patent [19]

Sacco et al.

[11] Patent Number: **Des. 368,448**

[45] Date of Patent: ****Apr. 2, 1996**

[54] **AUTOMOBILE**

[75] Inventors: **Bruno Sacco; Josef Gallitzendoerfer**, both of Sindelfingen; **Peter Pfeiffer**, Boeblingen, all of Germany

[73] Assignee: **Mercedes-Benz AG**, Stuttgart, Germany

[**] Term: **14 Years**

[21] Appl. No.: **27,404**

[22] Filed: **Aug. 18, 1994**

[30] Foreign Application Priority Data

Feb. 18, 1994 [DE] Germany M 94 01 346.2

[52] U.S. Cl. **D12/92**

[58] Field of Search D12/82-83, 86, D12/88-92; D21/78; 296/185-186

[56] References Cited

U.S. PATENT DOCUMENTS

D. 233,321 10/1974 Wilfert D12/92

OTHER PUBLICATIONS

Car and Driver, Audi Cabriolet, Jun. 1993, p. 70.

Car and Driver, Mercedes 190 class, Jun. 1992, p. 27.

Car and Driver, Mercedes Benz 600SL, Apr. 1993, p. 46.

Autocar & Motor, Mercedes 300CE-24 Cabriolet, Jul. 8, 1992, pp. 65-66.

Car and Driver, BMW 325i Convertible, Aug. 1993, p. 68.

Primary Examiner—M. H. Tung

Attorney, Agent, or Firm—Evenson McKeown Edwards & Lenahan

[57] CLAIM

The ornamental design for an automobile, as shown and described.

DESCRIPTION

FIG. 1 is a left side view of an automobile according to our novel ornamental design, the right side is a mirror image;

FIG. 2 is a front, left side perspective view of an automobile;

FIG. 3 is a rear, left side perspective view of an automobile;

FIG. 4 is a front view of an automobile; and,

FIG. 5 is a rear view of an automobile.

The broken line drawings of the wheels and license plate holders are for illustrative purposes only and form no part of the claimed design.

1 Claim, 4 Drawing Sheets

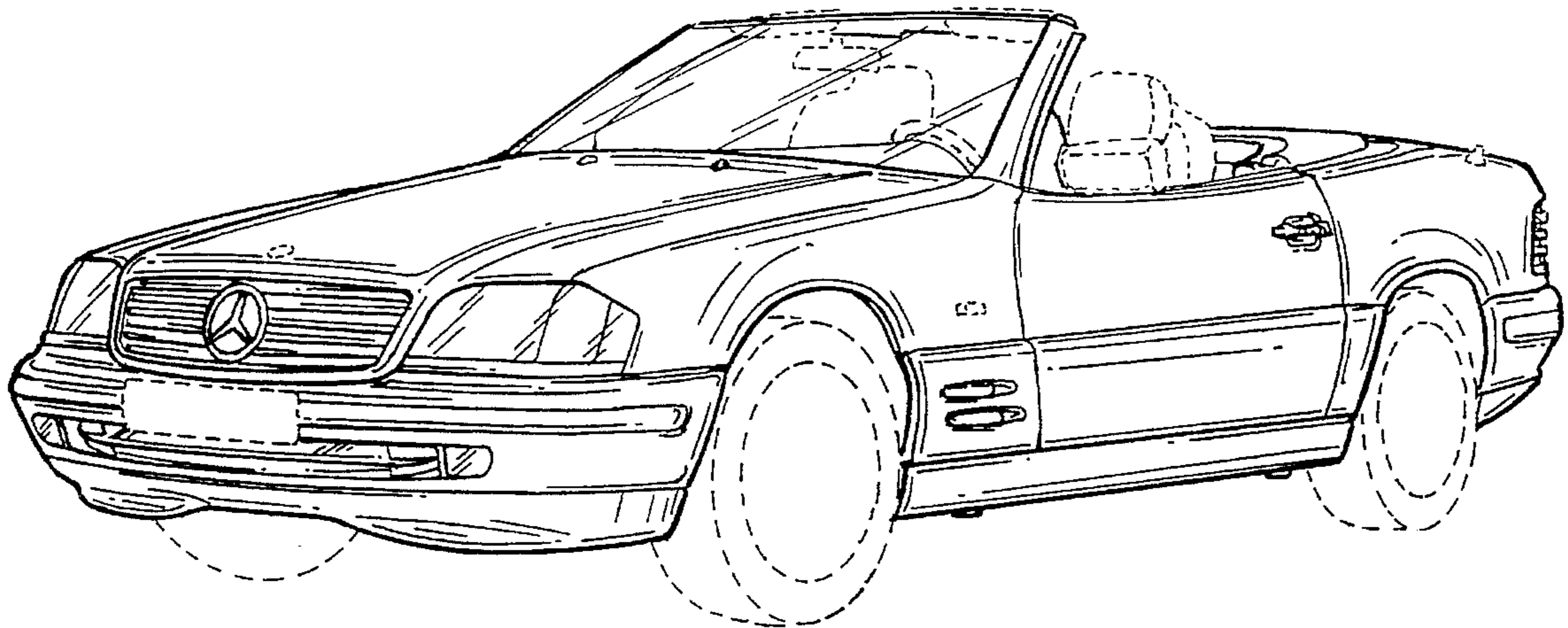

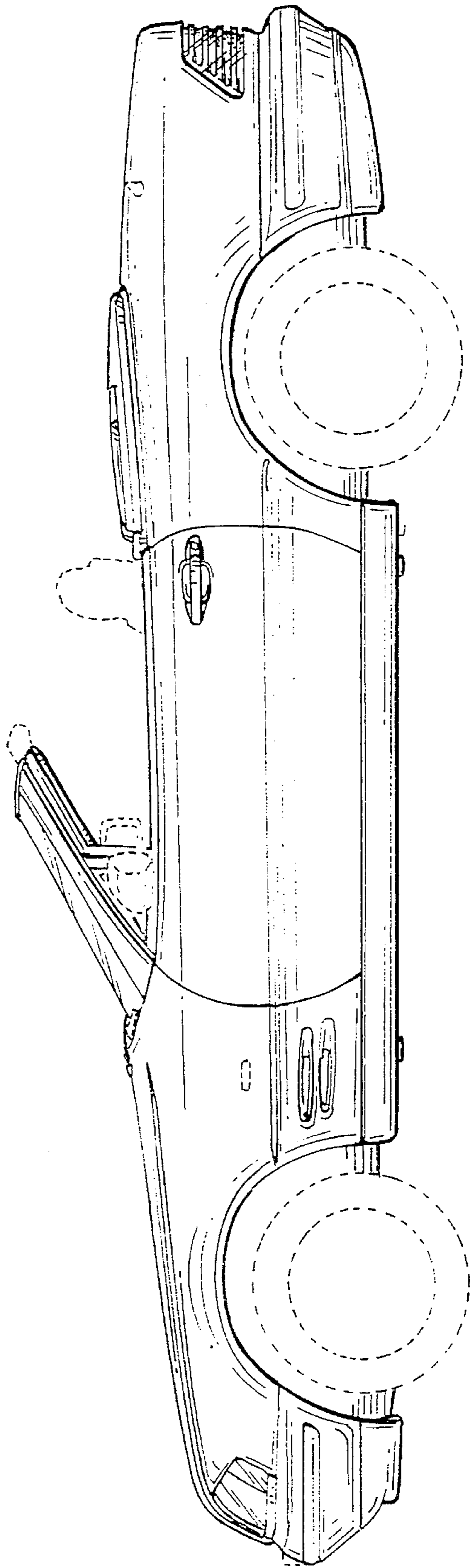

FIG. 1

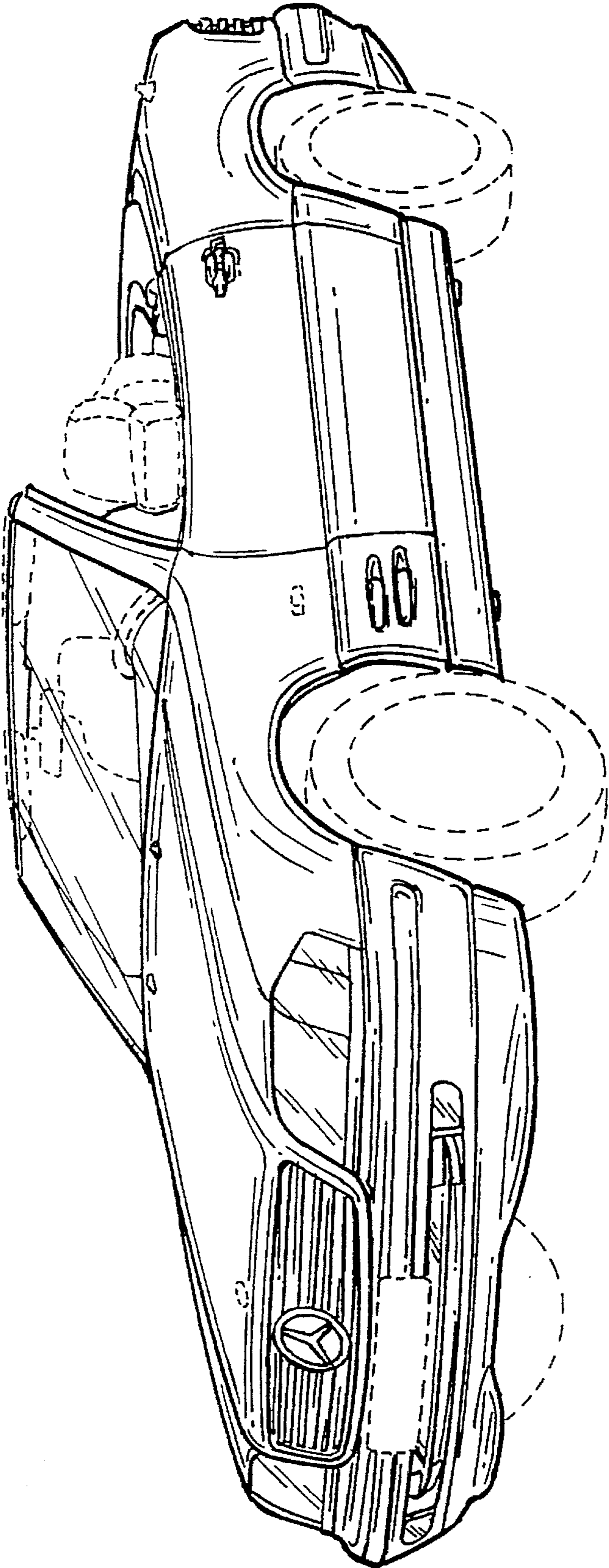

FIG. 2

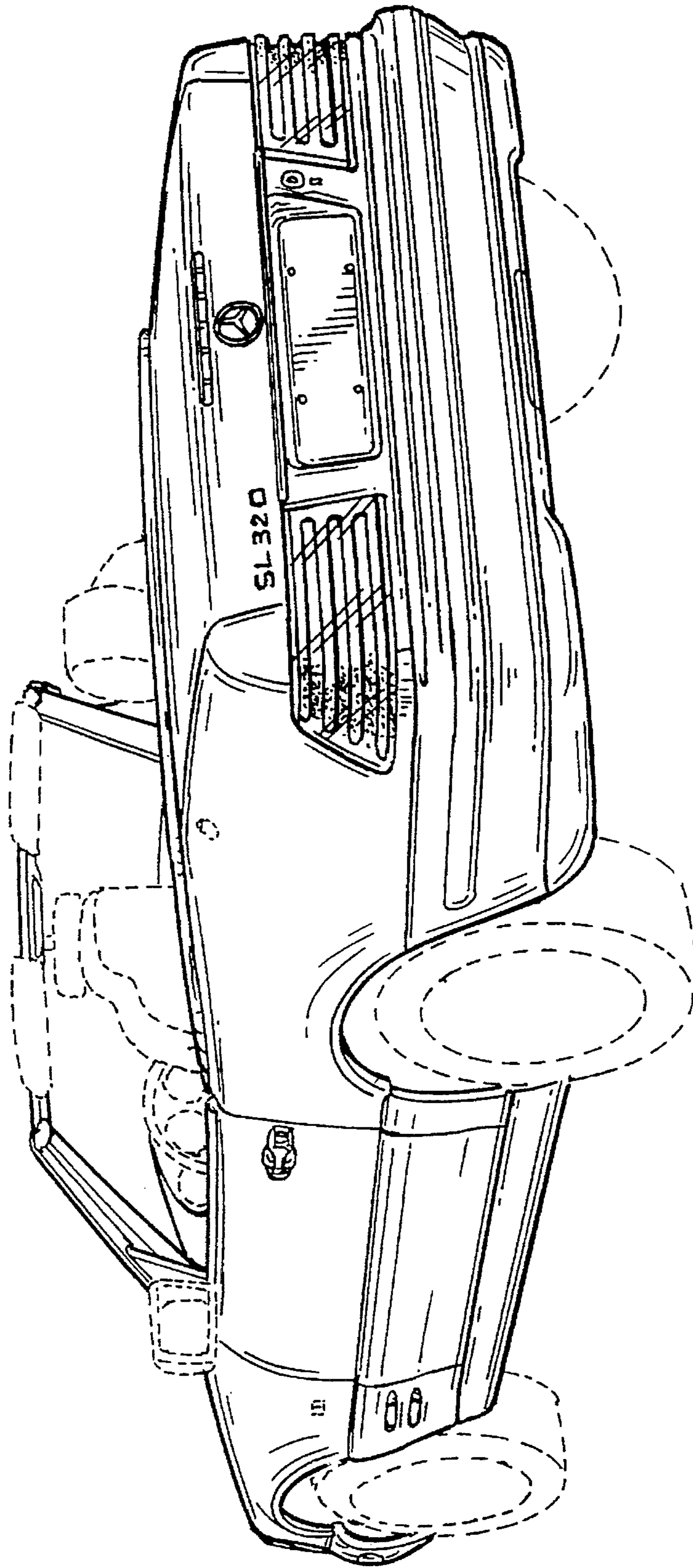

FIG. 3

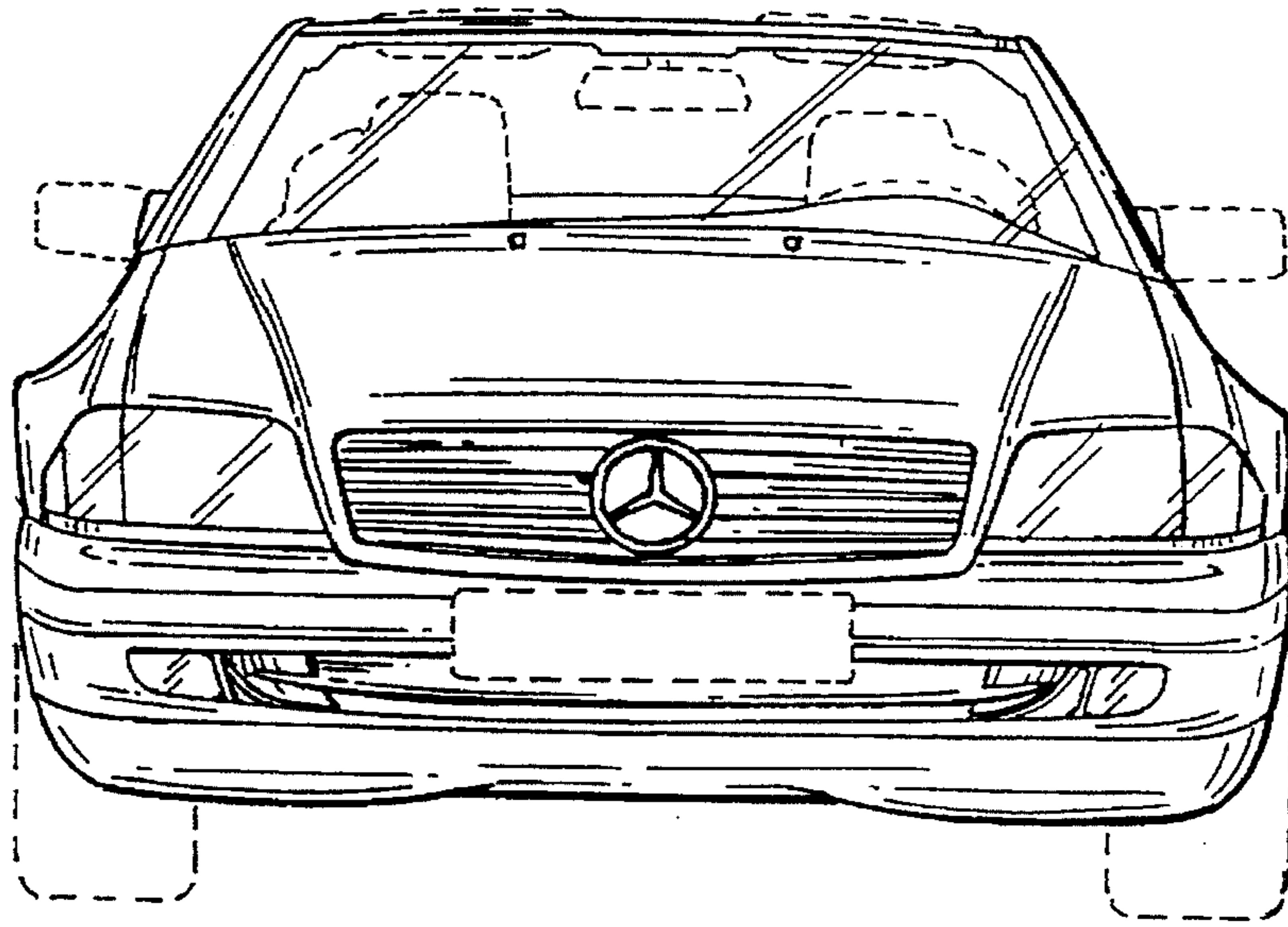

FIG. 4

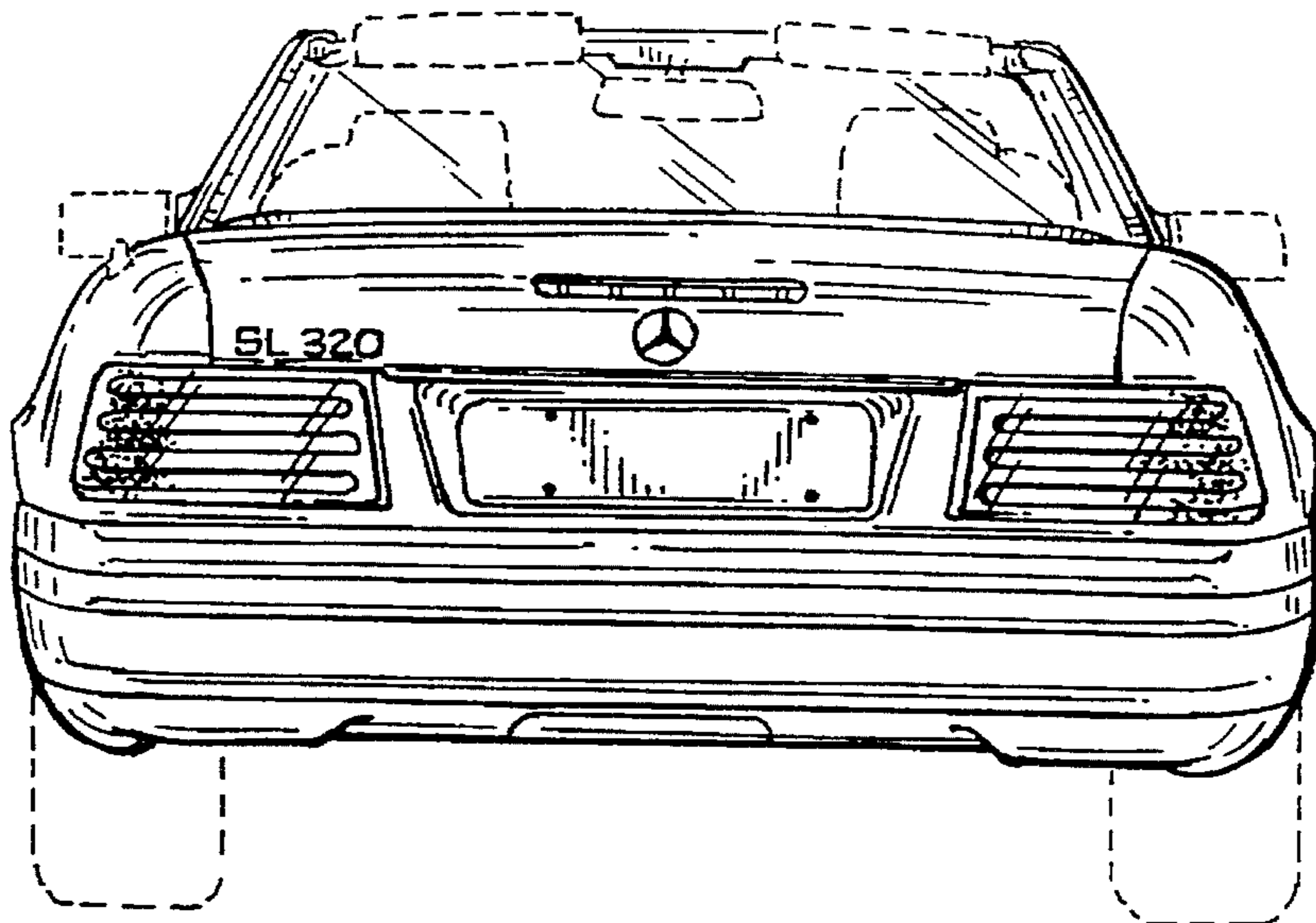

FIG. 5