



US00D368416S

United States Patent [19]

[11] Patent Number: **Des. 368,416**

Holman et al.

[45] Date of Patent: ****Apr. 2, 1996**

[54] **TIRE LIFT AND LUG REMOVER SET**

Assistant Examiner—Richelle Shelton
Attorney, Agent, or Firm—Bill D. McCarthy

[76] Inventors: **Louis W. Holman**, 3329 NW. 27th,
Oklahoma City, Okla. 73112; **Louis W.
Holman, Jr.**, 12116 Moritz Ct.,
Oklahoma City, Okla. 73162

[57] **CLAIM**

The ornamental design for a tire lift and lug remover set, as shown.

[**] Term: **14 Years**

DESCRIPTION

[21] Appl. No.: **30,655**

FIG. 1 is a perspective view of a tire lift and lug remover set showing our new design;

[22] Filed: **Nov. 4, 1994**

FIG. 2 is a top plan view of a first portion thereof;

[52] U.S. Cl. **D8/31; D8/14**

FIG. 3 is a bottom plan view thereof;

[58] Field of Search D8/105, 31, 14;
D34/28, 31; 7/100; 29/270, 273; 248/352;
254/120, 131; 280/402; 414/426-429

FIG. 4 is a right side elevational view thereof;

FIG. 5 is a left side elevational view thereof;

FIG. 6 is front elevational view thereof;

FIG. 7 is a rear elevational view thereof;

[56] References Cited

U.S. PATENT DOCUMENTS

D. 335,739	5/1993	Holman et al.	D34/31
D. 343,997	2/1994	Smith	D8/14
D. 347,981	6/1994	Suggs	D8/14
1,747,775	2/1930	Houston	29/270
2,212,716	8/1940	Noble et al.	7/100 X
2,504,345	4/1950	Nellis	7/100
2,639,121	5/1953	Hudspeth	254/131
4,534,579	8/1985	Shackelford, Sr.	280/402
4,632,629	12/1986	Kooima	414/563
5,176,487	1/1993	Flitton	254/131

FIG. 8 is a top plan view of a second portion thereof;

FIG. 9 is a bottom plan view thereof;

FIG. 10 is a left side elevational view thereof;

FIG. 11 is a right side elevational view thereof;

FIG. 12 is a rear elevational view thereof;

FIG. 13 is a front elevational view thereof;

FIG. 14 is a top rear perspective view of the tire lift and lug remover set in its folded position; and,

FIG. 15 is a bottom front perspective view thereof in its folded position.

The portions of the set have been shown separately in FIGS. 1-13 for clarity of illustration.

Primary Examiner—Ted Shooman

1 Claim, 4 Drawing Sheets

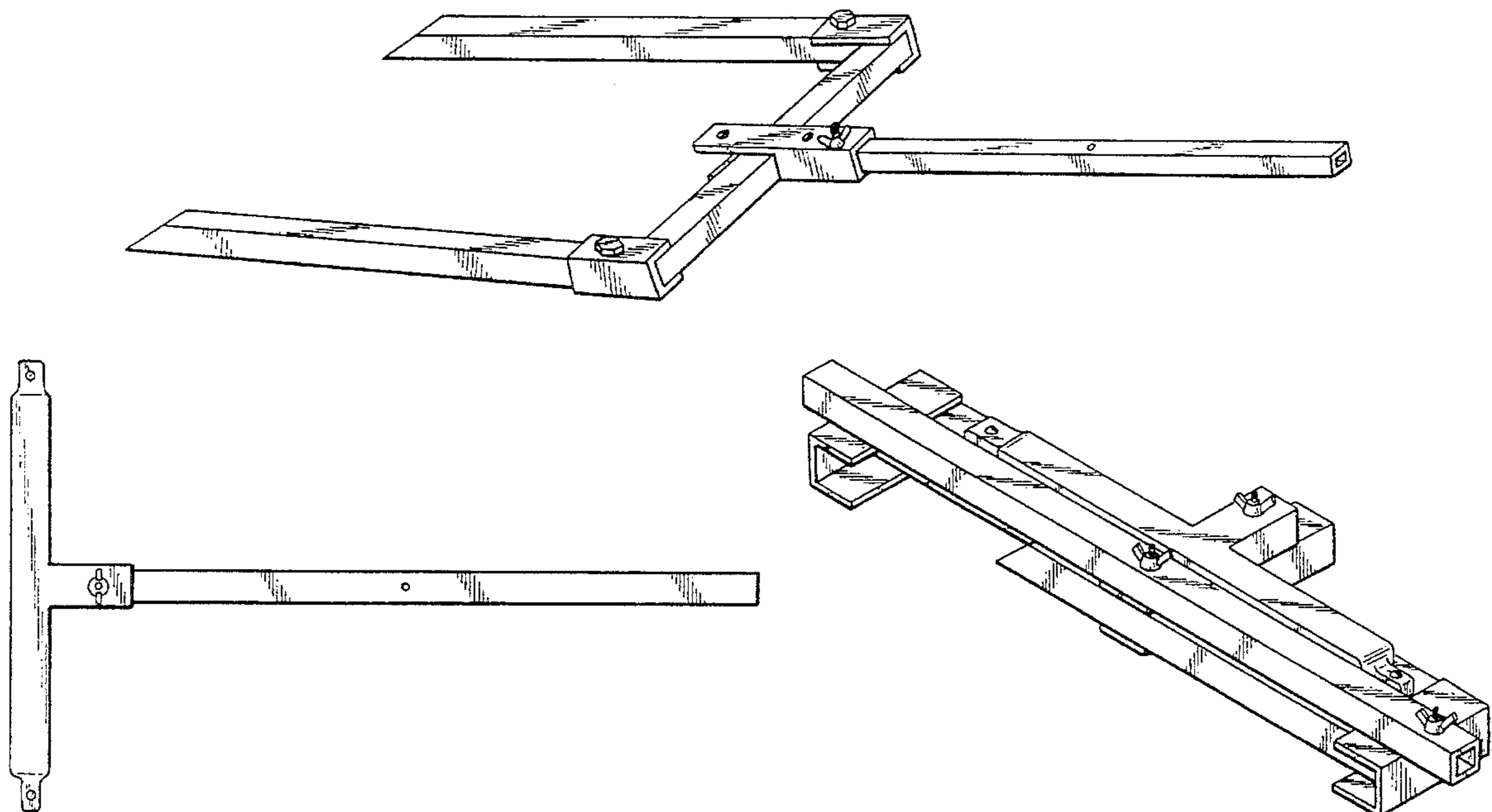

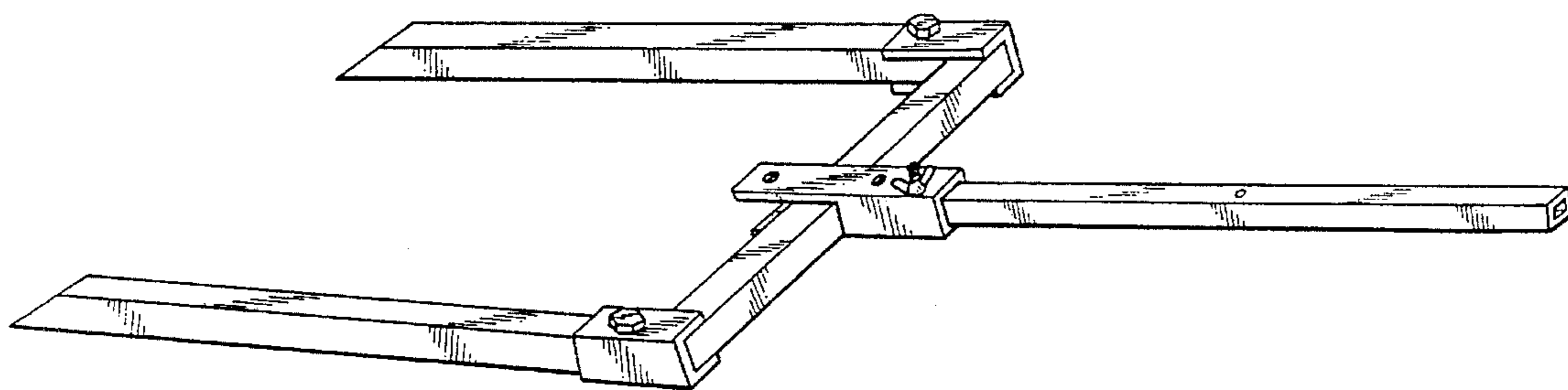

FIG. 1

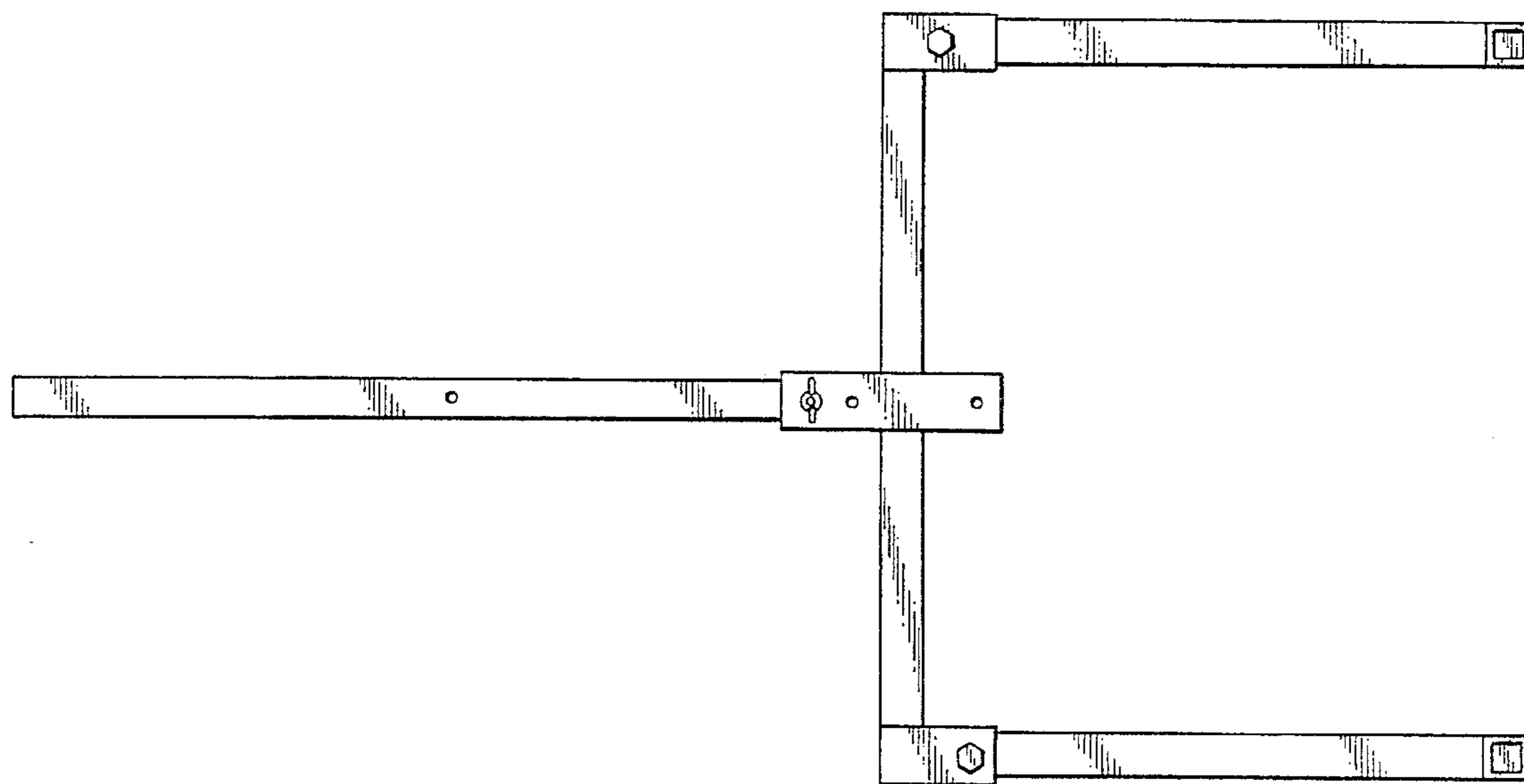
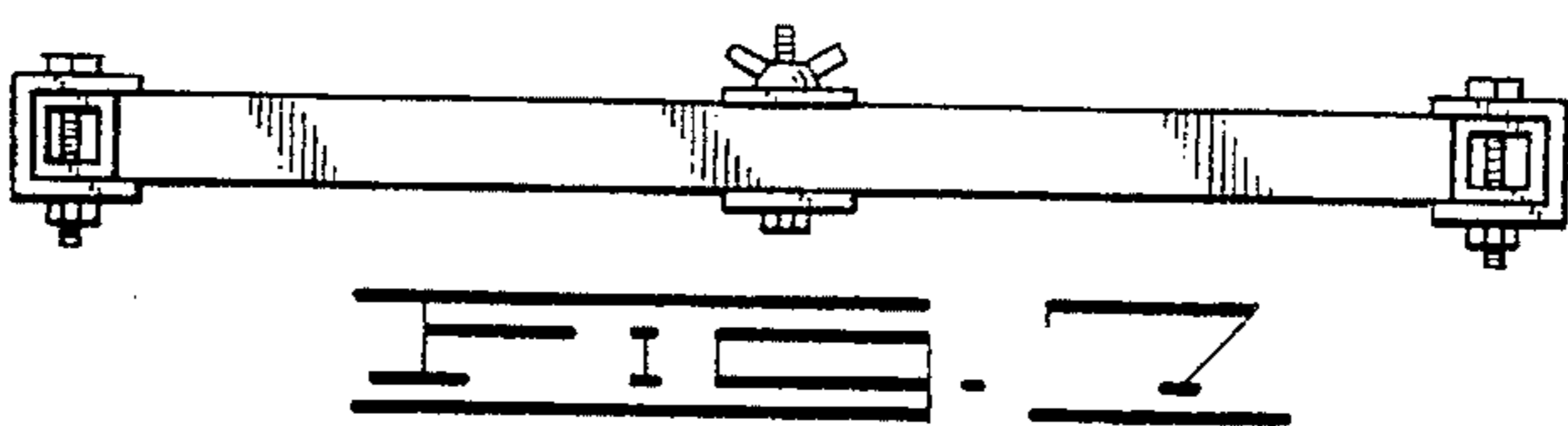
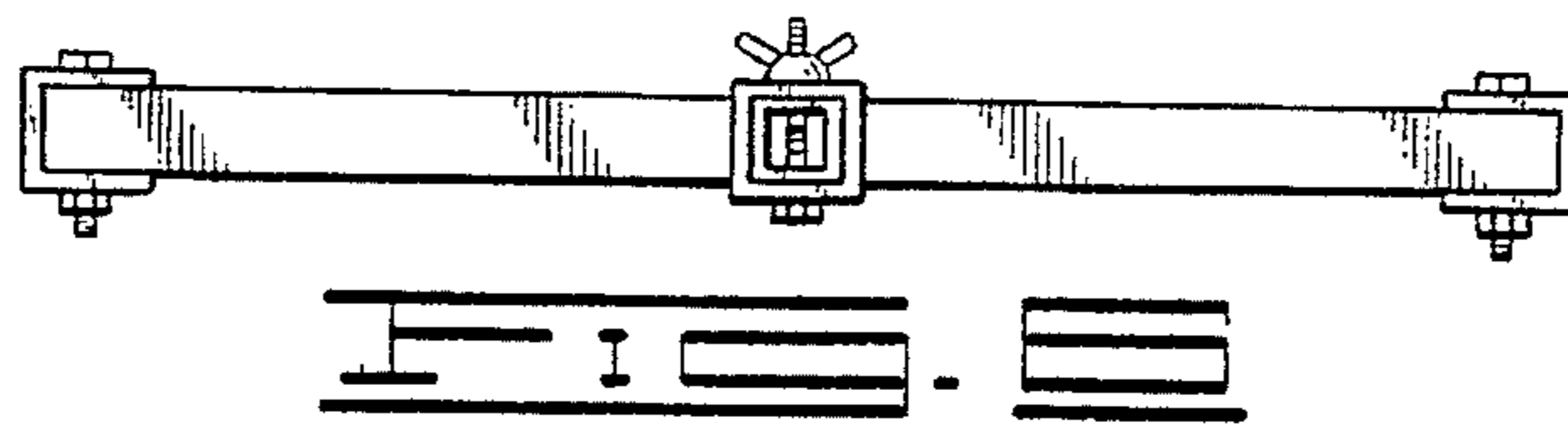
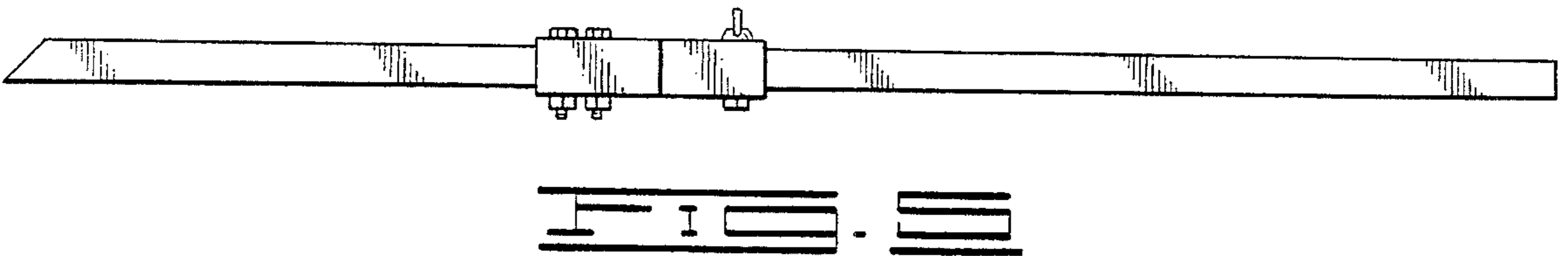
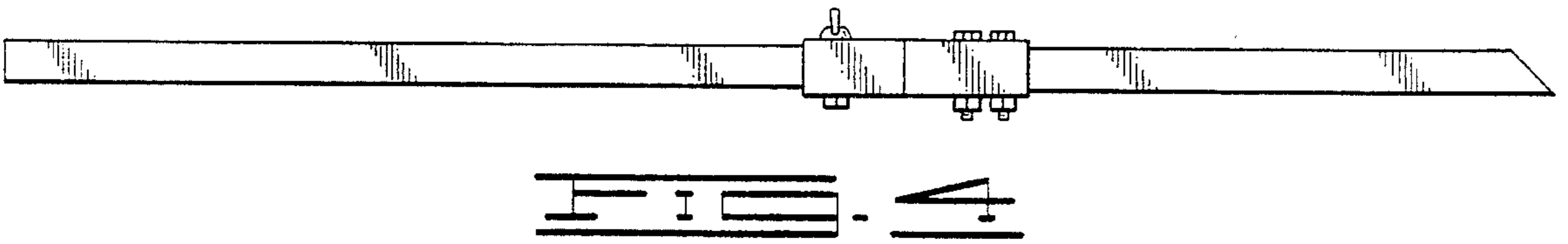
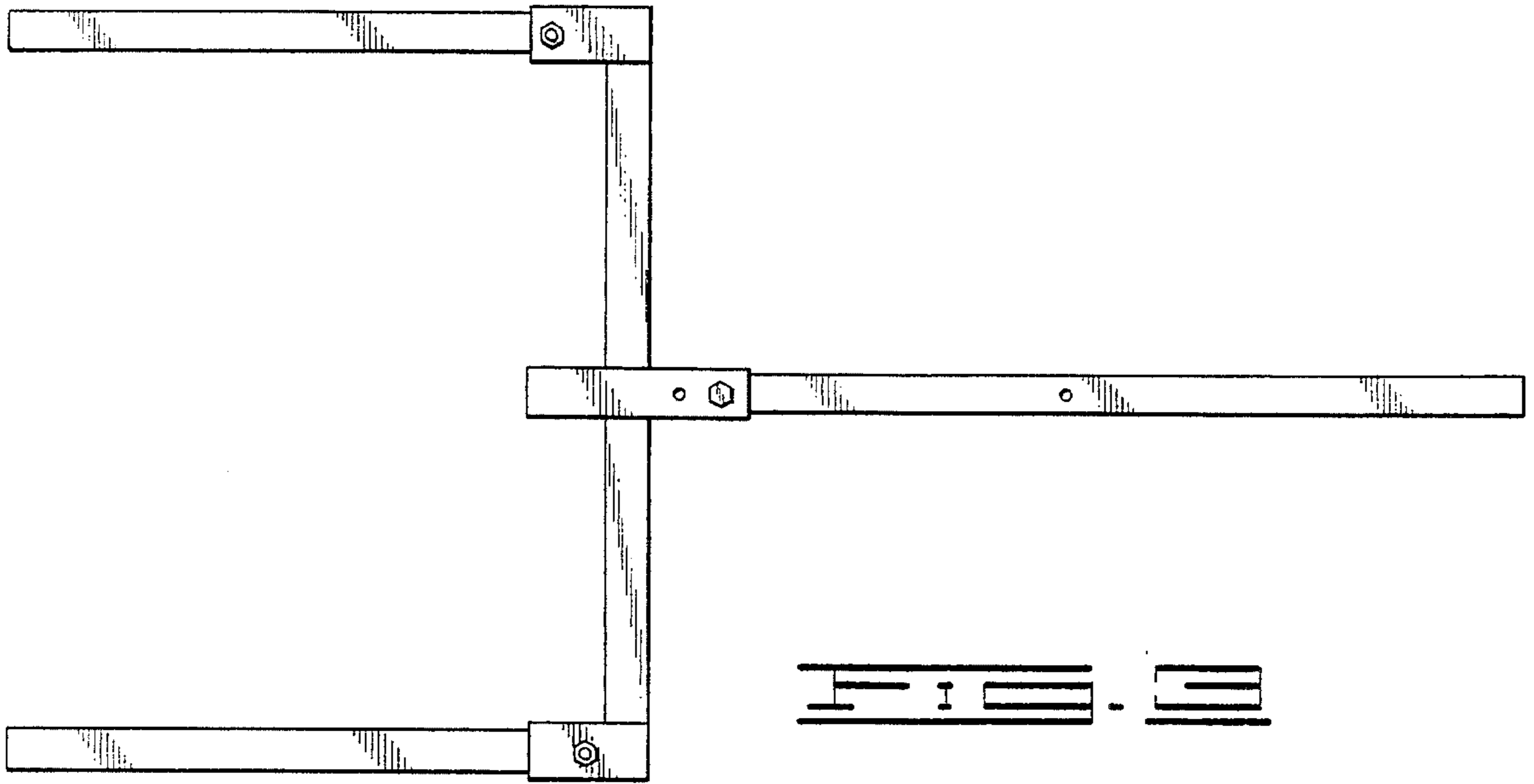
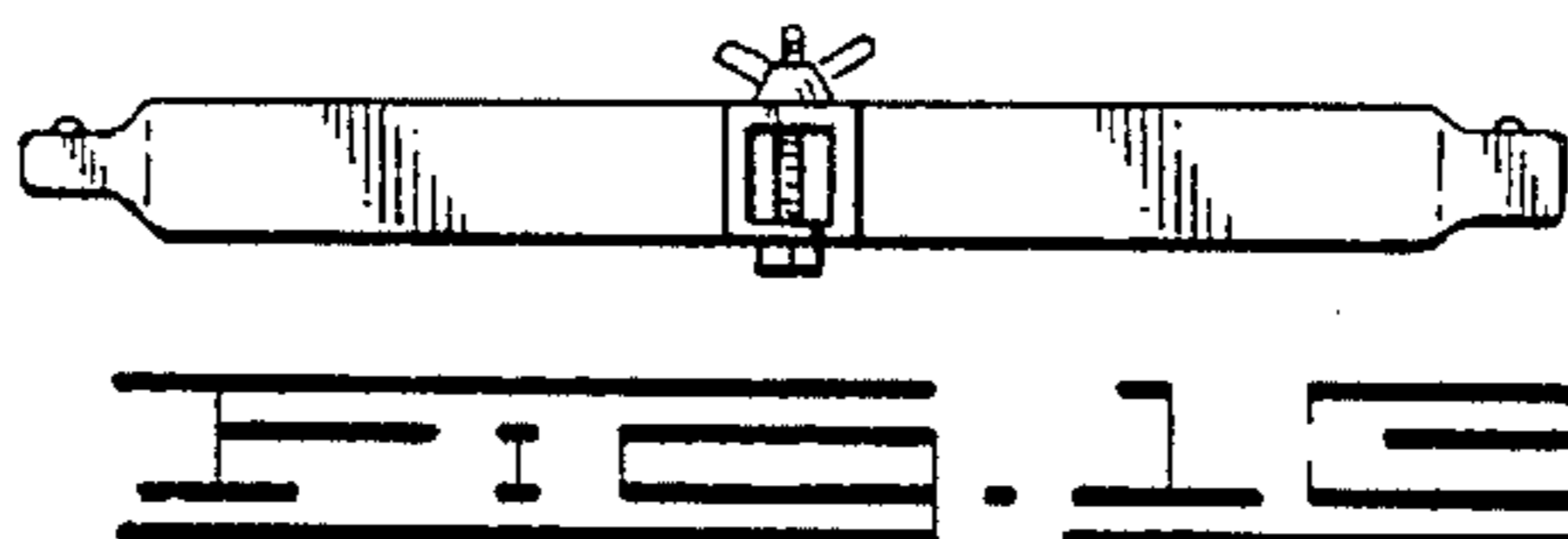
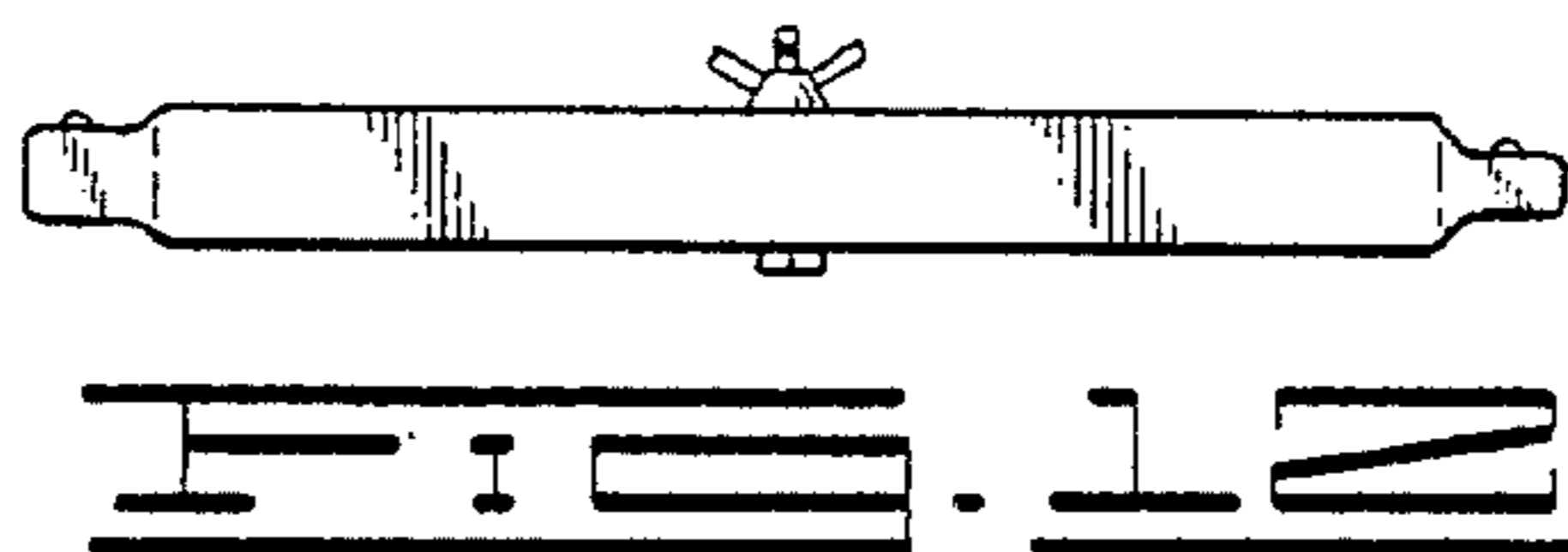
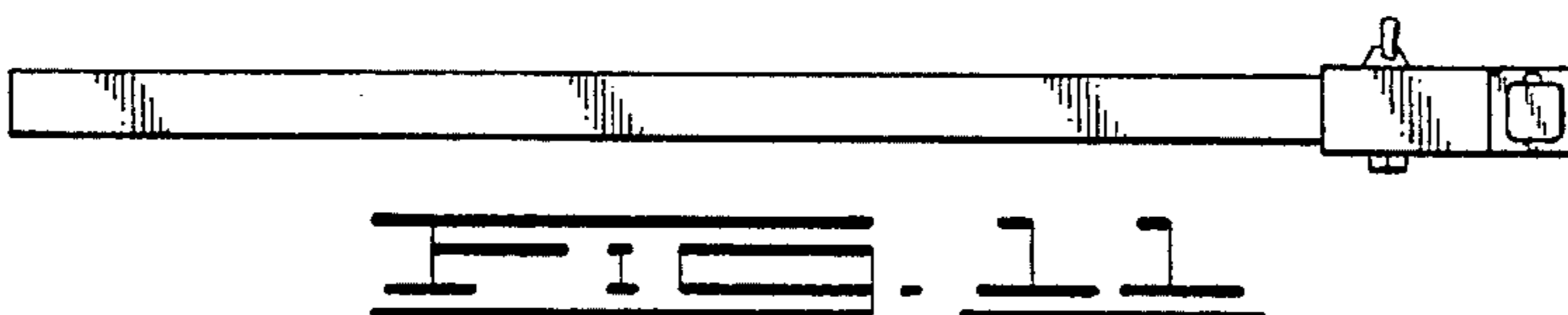
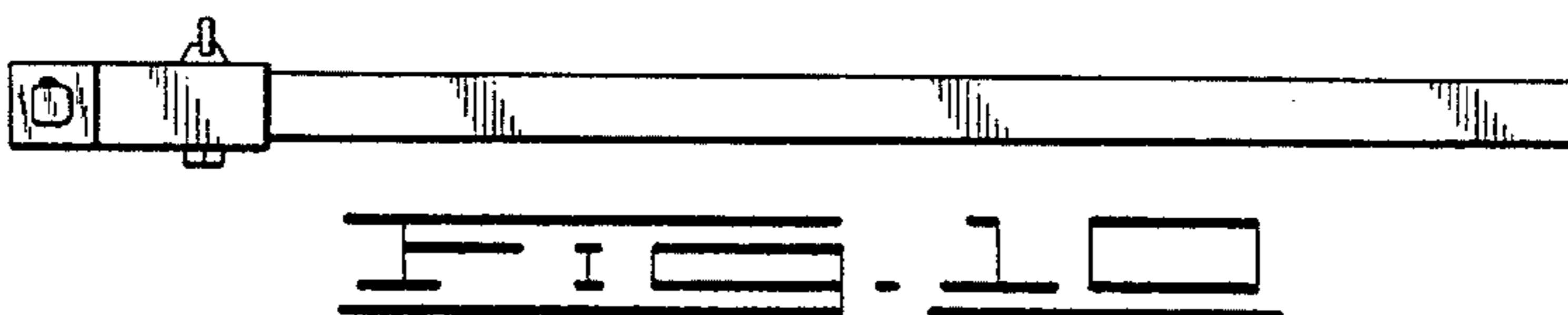
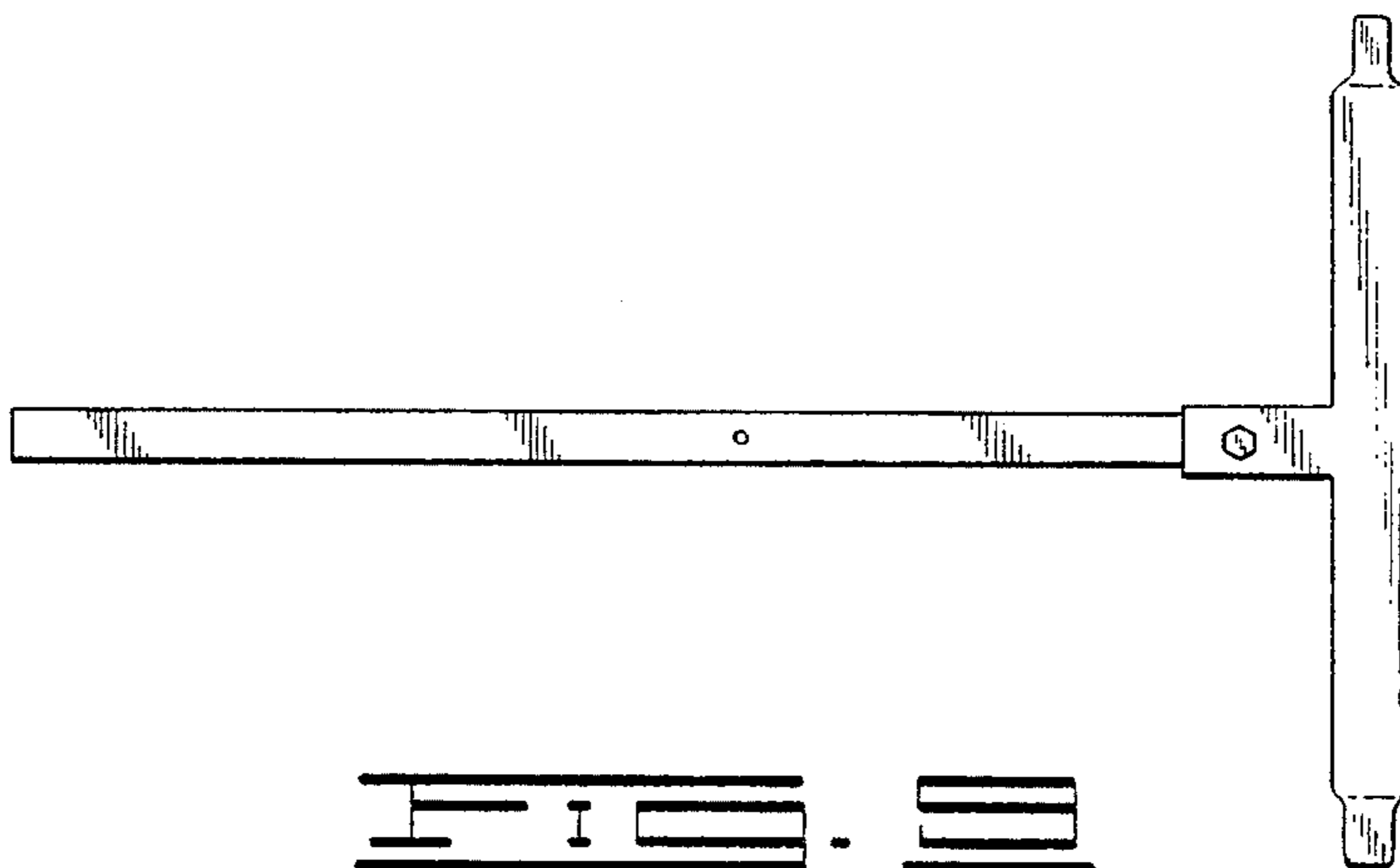
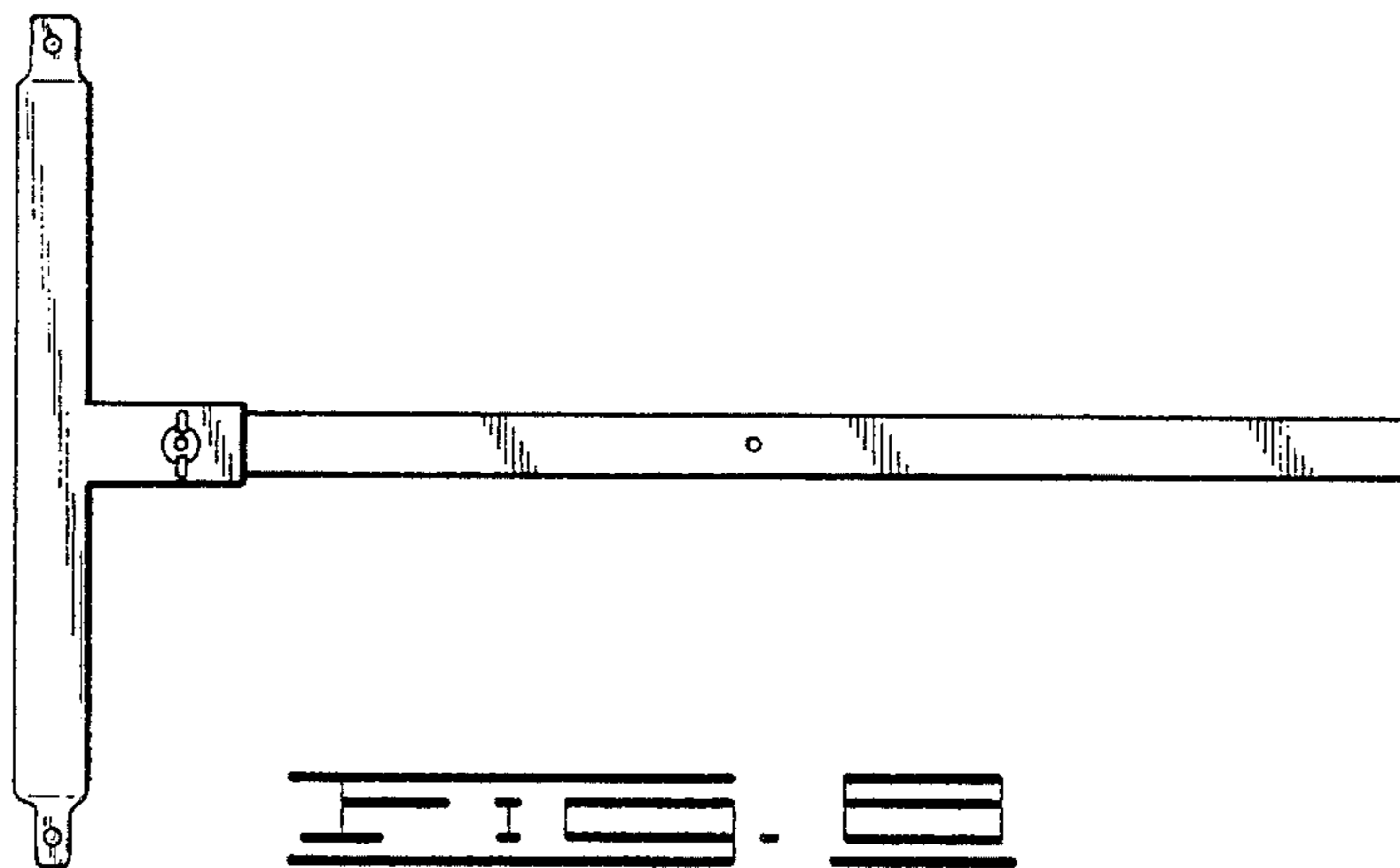

FIG. 2





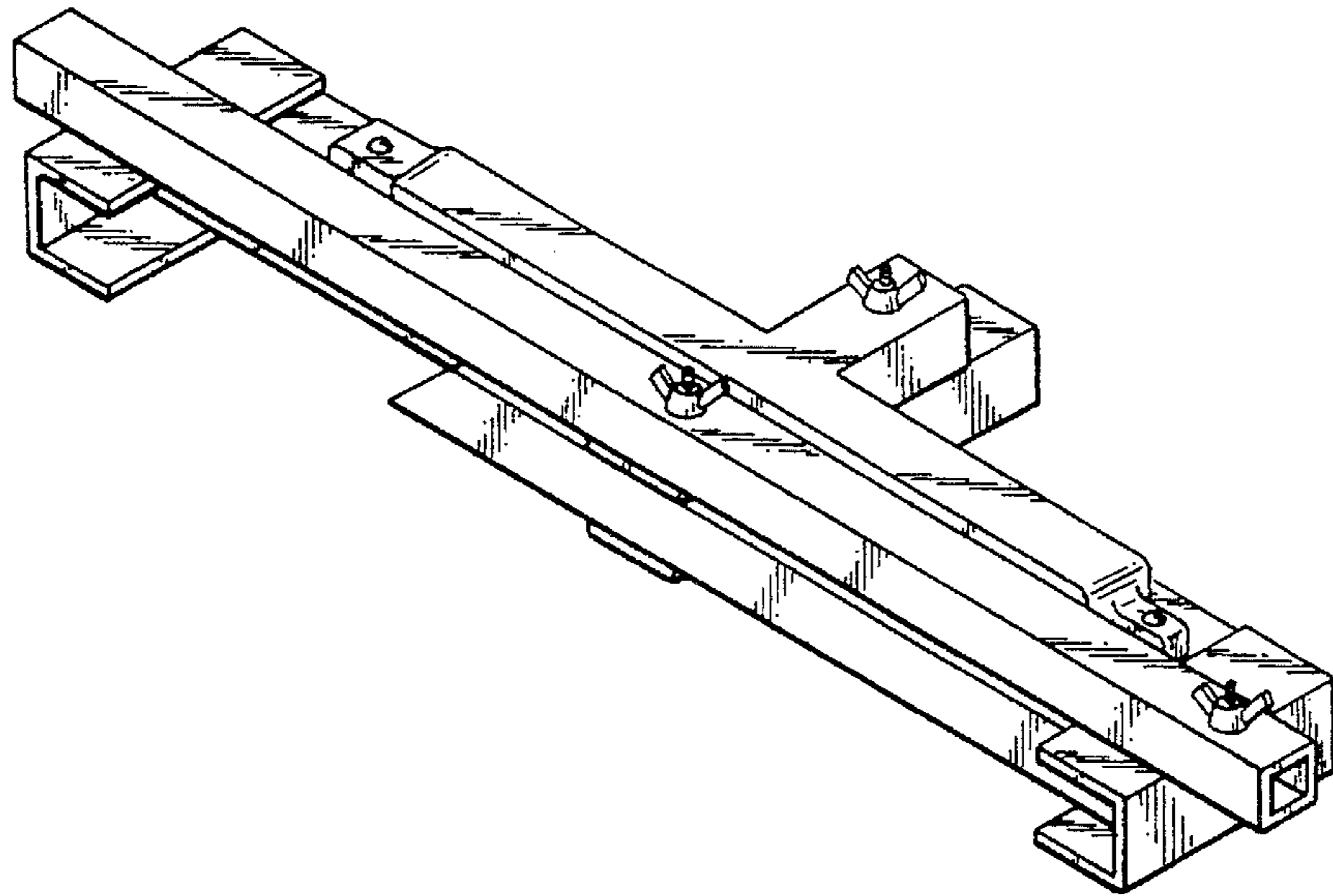

FIG. 14

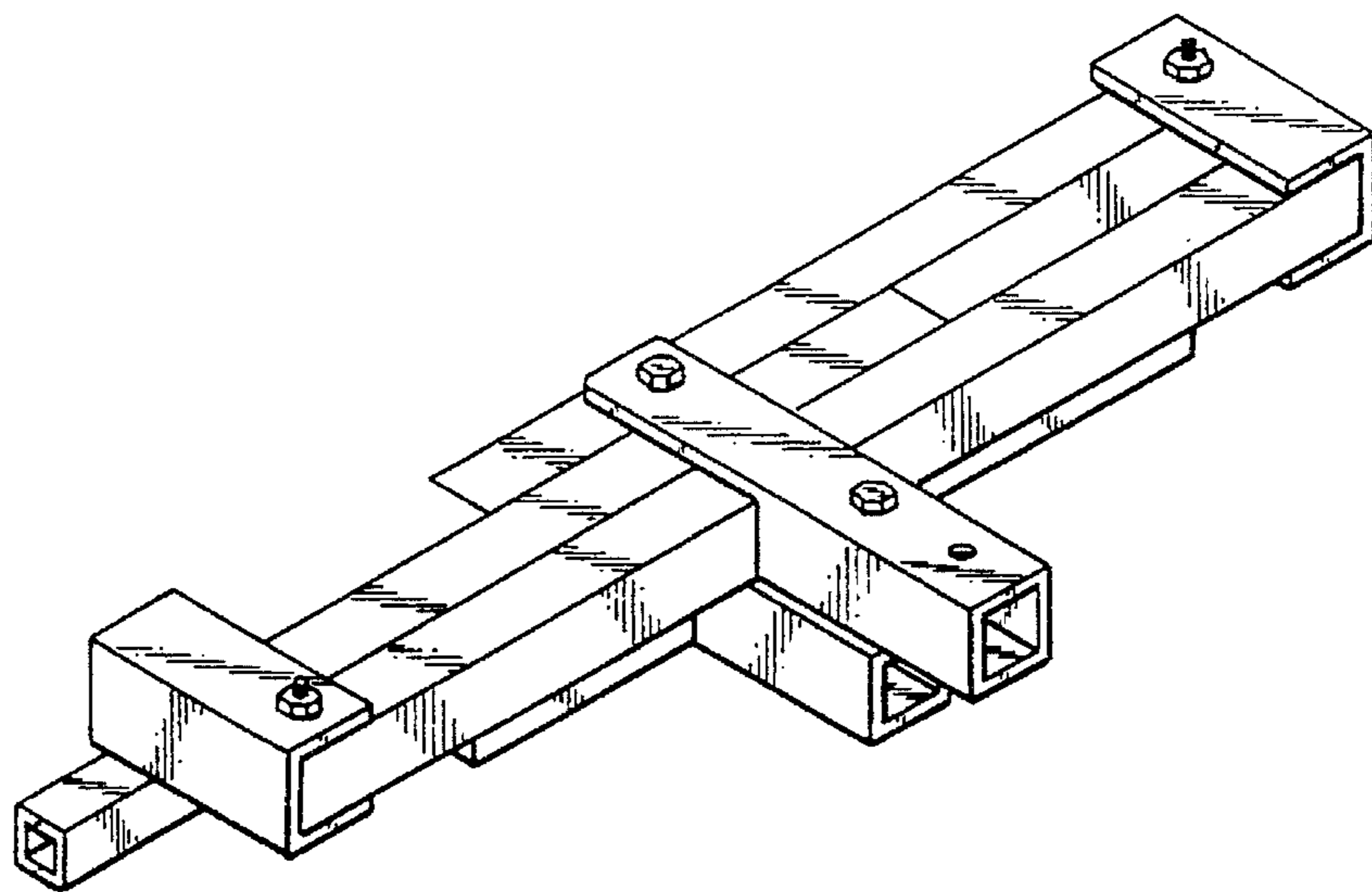

FIG. 15