



US00D368287S

# United States Patent [19]

[11] Patent Number: **Des. 368,287**

Walter

[45] Date of Patent: **\*\*Mar. 26, 1996**

[54] **TOY RIDE-IN TRUCK**

[75] Inventor: **Christopher G. Walter**, Suffield, Ohio

[73] Assignee: **The Little Tikes Company**, Hudson, Ohio

[\*\*] Term: **14 Years**

[21] Appl. No.: **25,213**

[22] Filed: **Jul. 29, 1994**

[52] U.S. Cl. .... **D21/78**

[58] Field of Search ..... D21/71, 76, 78, D21/133-137, 140; D12/90-92; 446/93, 95, 128, 465, 468, 470; 280/87.01, 87.021, 87.051, 828

[56] **References Cited**

### U.S. PATENT DOCUMENTS

D. 236,607	9/1975	Bundschuh et al. ....	D12/107
D. 242,273	11/1976	Brass .....	D21/134
D. 242,701	12/1976	Viniegra .....	D12/91
D. 243,546	3/1977	Peterson .....	D21/134
D. 246,299	11/1977	Haggard .....	D12/90
D. 248,119	6/1978	Nix et al. ....	D21/134
D. 264,608	5/1982	Mariol .....	D21/78
D. 269,098	5/1983	Mariol .....	D21/78
D. 277,494	2/1985	Lerch .....	D21/136
D. 303,776	10/1989	Aker .....	D12/108
D. 312,488	11/1990	Kwan .....	D21/136
D. 338,925	8/1993	VanHuystee .....	D21/78
3,659,378	5/1972	Tong .....	46/244

### OTHER PUBLICATIONS

P. 119, Ride-on vehicles; Montgomery Ward, address unknown. Publication date 1983.

P. 48, Pick-up truck; Buddy L, a Division of SLM, Patch

Road RD1, P.O. Box 1070, Gloversville, new York 12078. Publication date 1993.

P. T-6, Pick-up truck; Hasbro, Inc., 1027 Newport Avenue, P.O. Box 1059, Pawtucket, Rhode Island 02862. Publication date 1992.

Pp. 24 and 66, Pick-up trucks; Tyco Toys, Inc., 6000 Midlantic Drive, Mount Laurel, New Jersey 08054. Publication date 1993.

P. 14, 4x4 Truck; Blazon-Flexible Flyer Inc., 100 Tubb Avenue, West Point, Mississippi 39773. Publication date 1988.

*Primary Examiner*—Prabhakar G. Deshmukh

*Assistant Examiner*—R. Barkai

*Attorney, Agent, or Firm*—Richard B. O'Planick; Lisa B. Riedesel

[57] **CLAIM**

The ornamental design for a toy ride-in truck, as shown and described.

### DESCRIPTION

FIG. 1 is a top left front perspective view of a toy ride-in truck showing my new design;

FIG. 2 is a top plan view thereof;

FIG. 3 is a left side elevational view thereof; the right side elevational view being a mirror image;

FIG. 4 is a bottom plan view thereof;

FIG. 5 is a front elevational view thereof; and,

FIG. 6 is a rear elevational view thereof.

The broken line showing of the wheels in FIGS. 1 and 3-6 is for illustrative purposes only and forms no part of the claimed design.

**1 Claim, 3 Drawing Sheets**

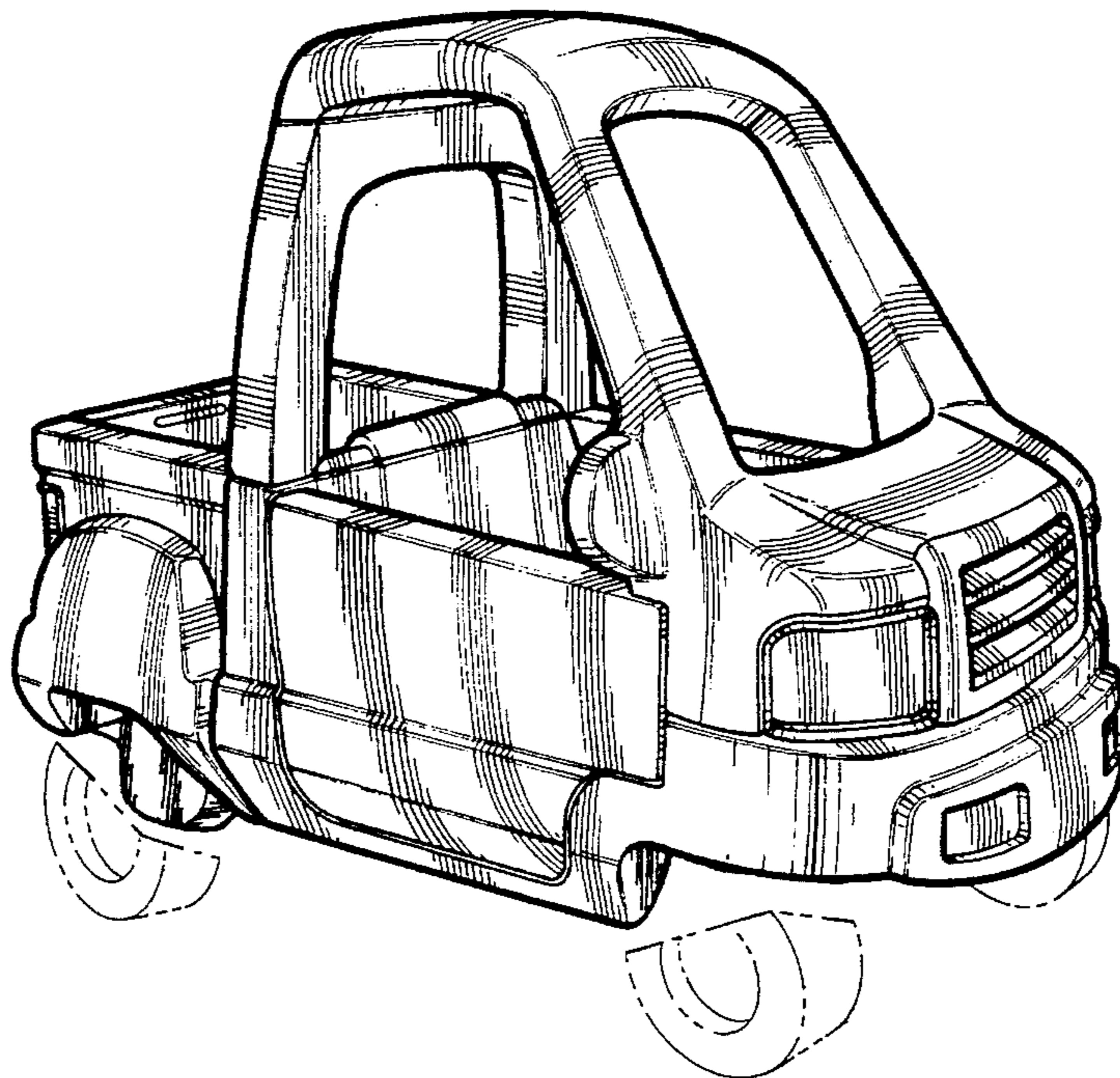

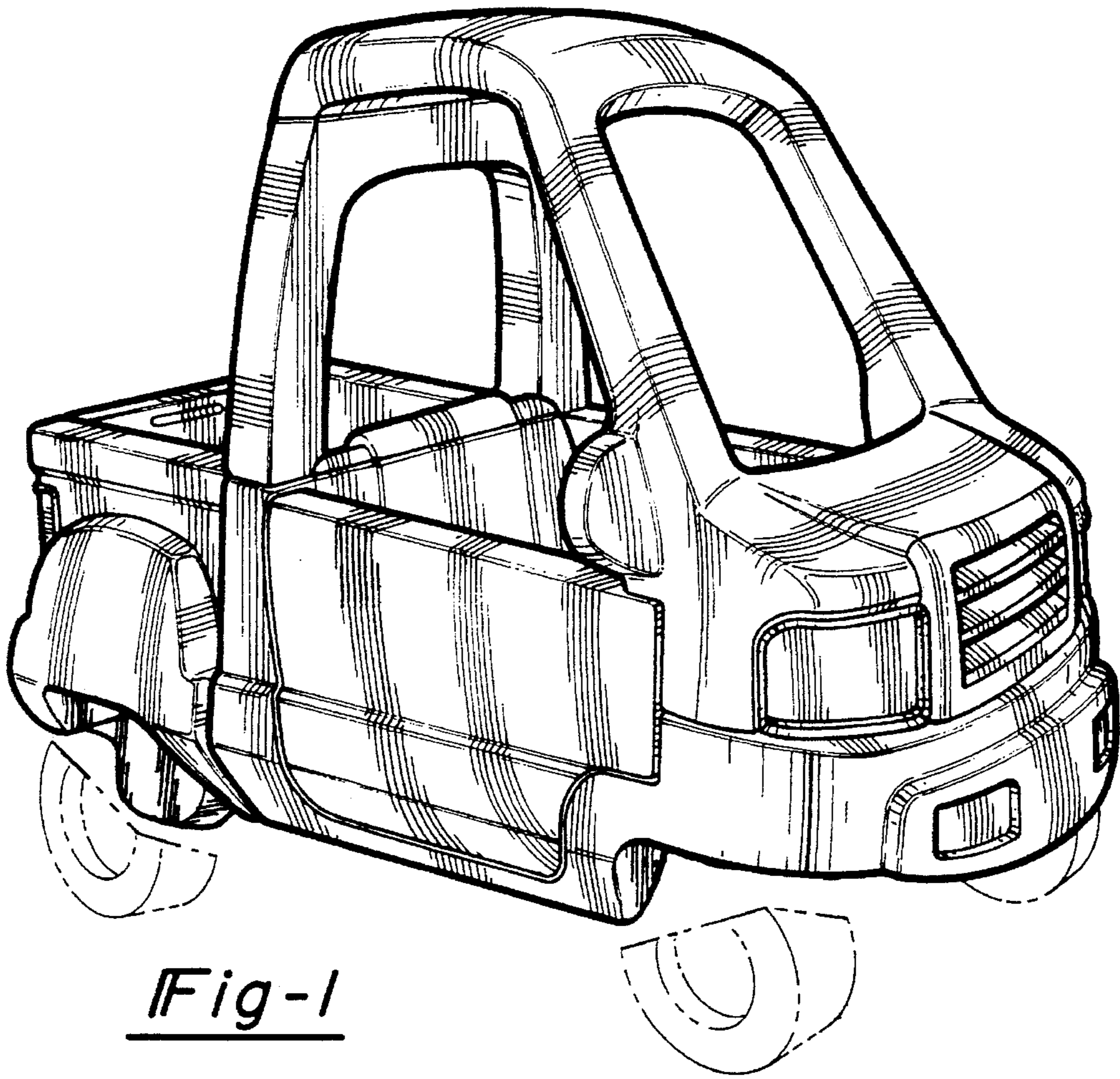

Fig-1

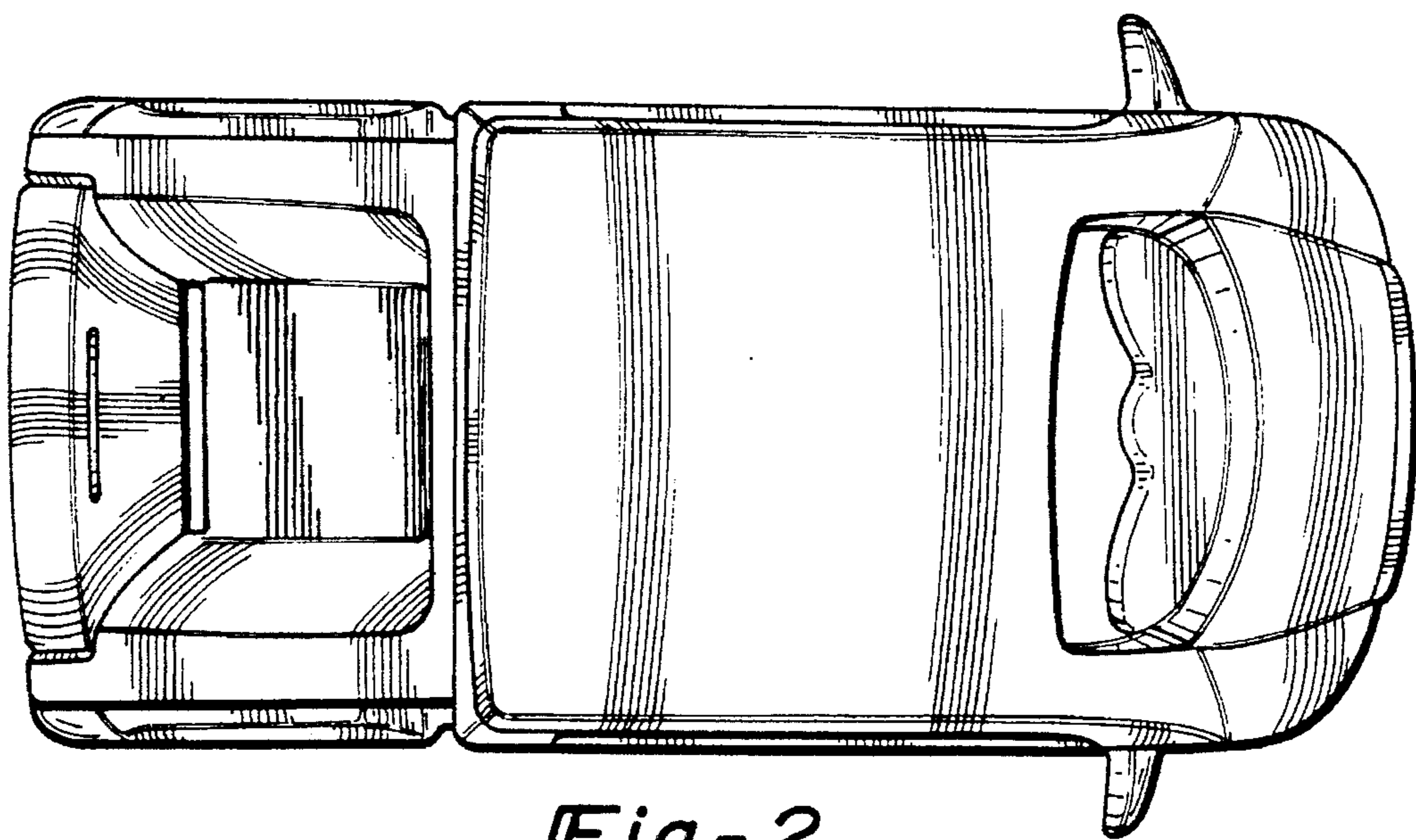

Fig-2

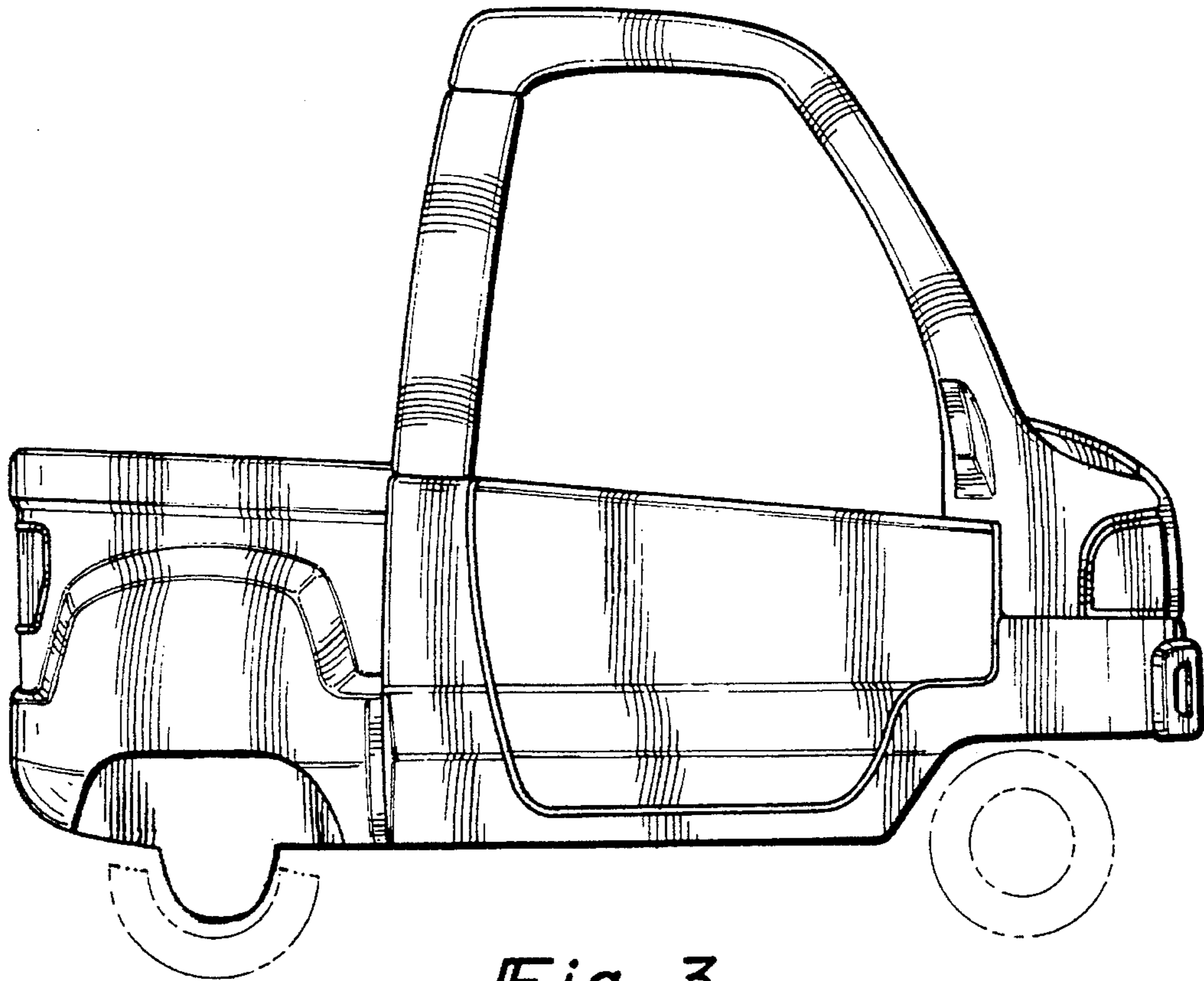

Fig-3

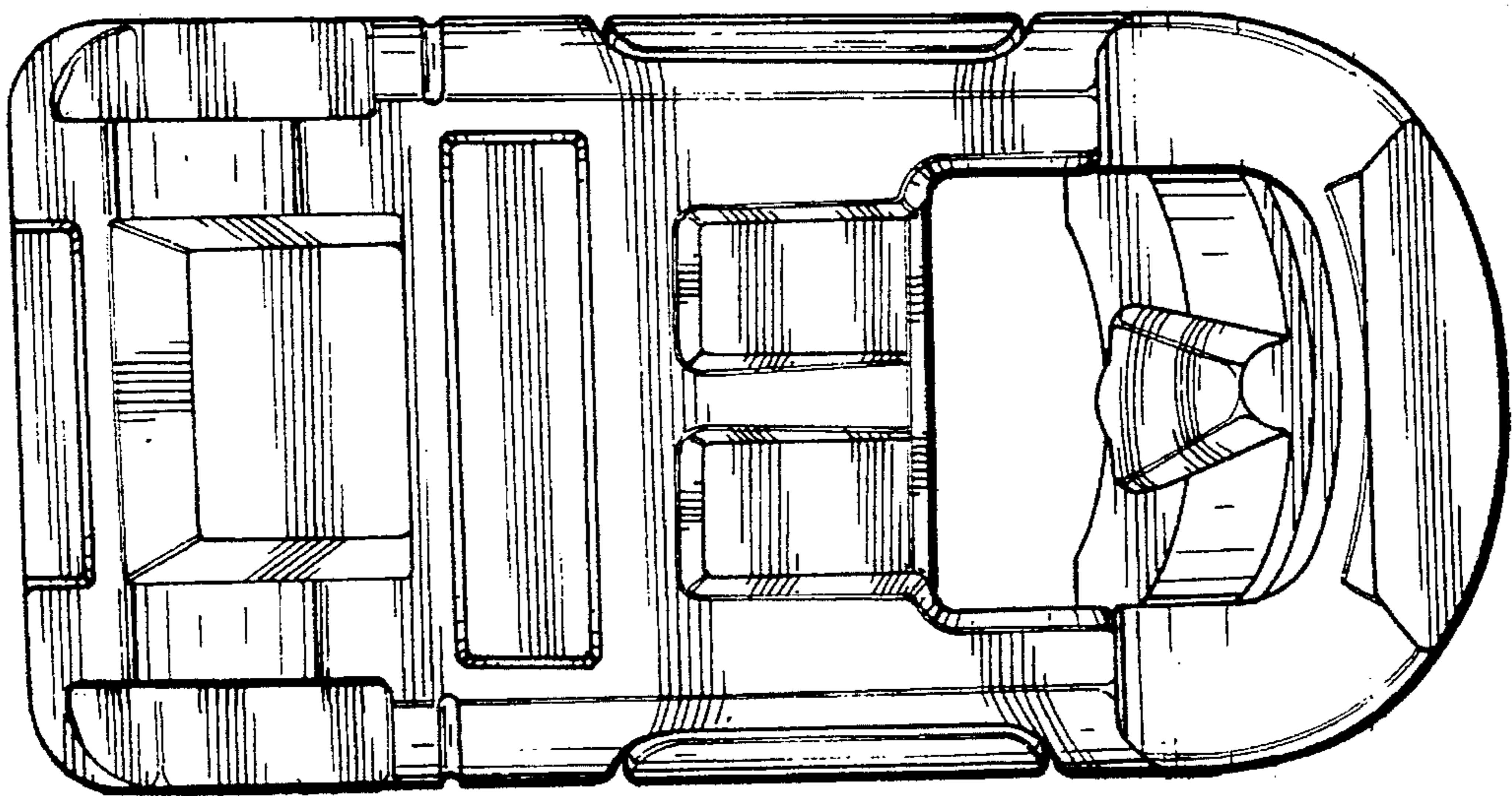

Fig-4

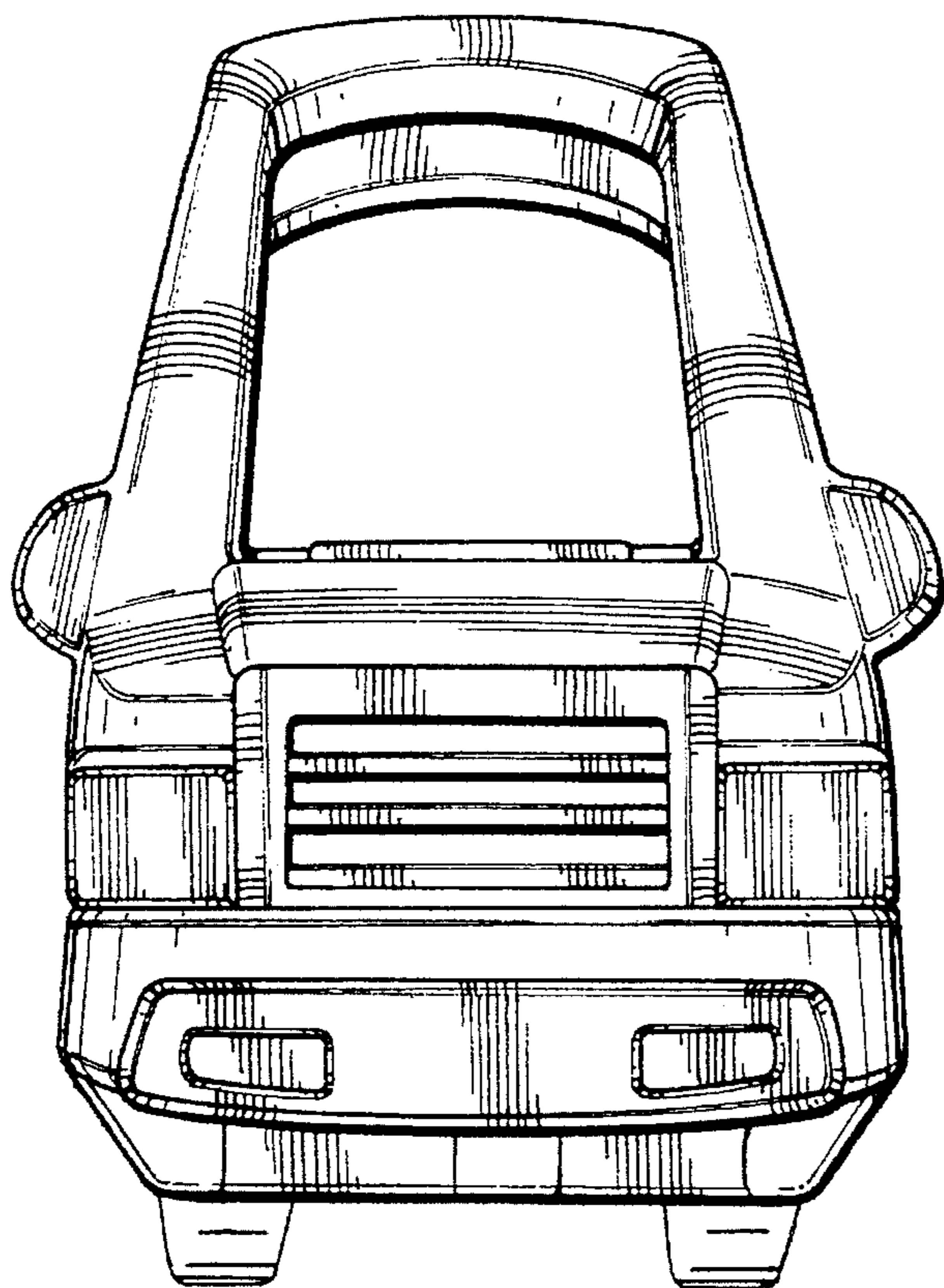

Fig-5

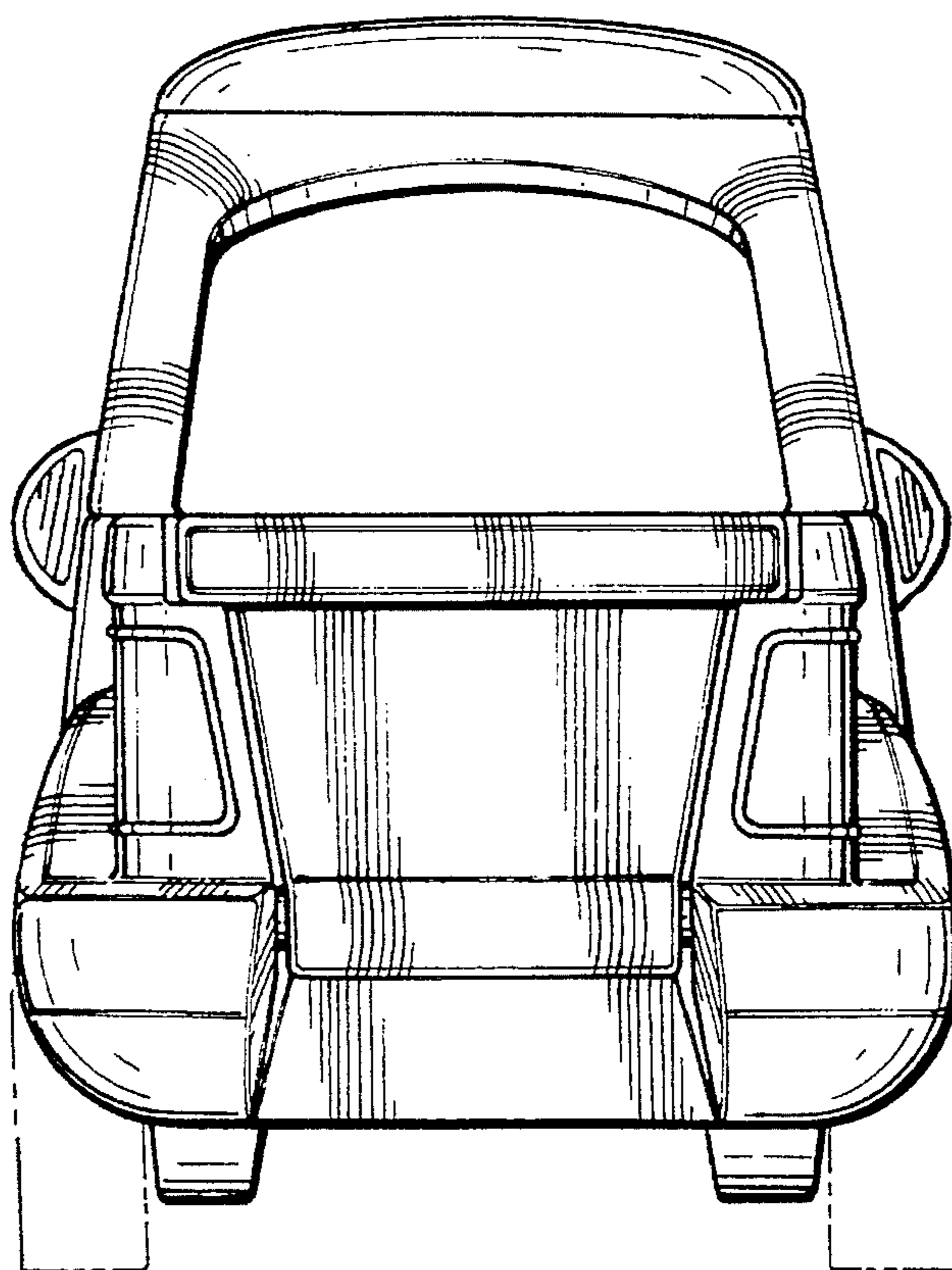

Fig-6