



US00D368269S

**United States Patent** [19]  
**Chapman**

[11] **Patent Number: Des. 368,269**

[45] **Date of Patent: \*\*Mar. 26, 1996**

[54] **COMPRESSOR HOUSING FOR A DIESEL TURBOCHARGER**

[76] Inventor: **Randy J. Chapman**, 955 Jones Rd., Yuba City, Calif. 95991

[\*\*] Term: **14 Years**

[21] Appl. No.: **32,734**

[22] Filed: **Dec. 27, 1994**

[52] U.S. Cl. .... **D15/5**

[58] Field of Search ..... D15/1-9.2; 415/200, 415/201, 213.1

[56] **References Cited**

**U.S. PATENT DOCUMENTS**

- D. 259,491 6/1981 Feuling ..... D15/5
- D. 268,585 4/1983 Drakulic ..... D15/5
- D. 285,570 9/1986 McInerney ..... D15/5

D. 352,720 11/1994 Gildersleeve et al. .... D15/7

*Primary Examiner*—Ralf Seifert  
*Attorney, Agent, or Firm*—Feix & Feix

[57] **CLAIM**

The ornamental design for a compressor housing for a diesel turbocharger, as shown and described.

**DESCRIPTION**

FIG. 1 is a front perspective view of the compressor housing for a diesel turbocharger of the present invention; FIG. 2 is a front elevational view thereof; FIG. 3 is a right side elevational view thereof; FIG. 4 is a rear elevational view thereof; FIG. 5 is a left side elevational view thereof; FIG. 6 is a top plan view thereof; and, FIG. 7 is a bottom plan view thereof.

**1 Claim, 1 Drawing Sheet**

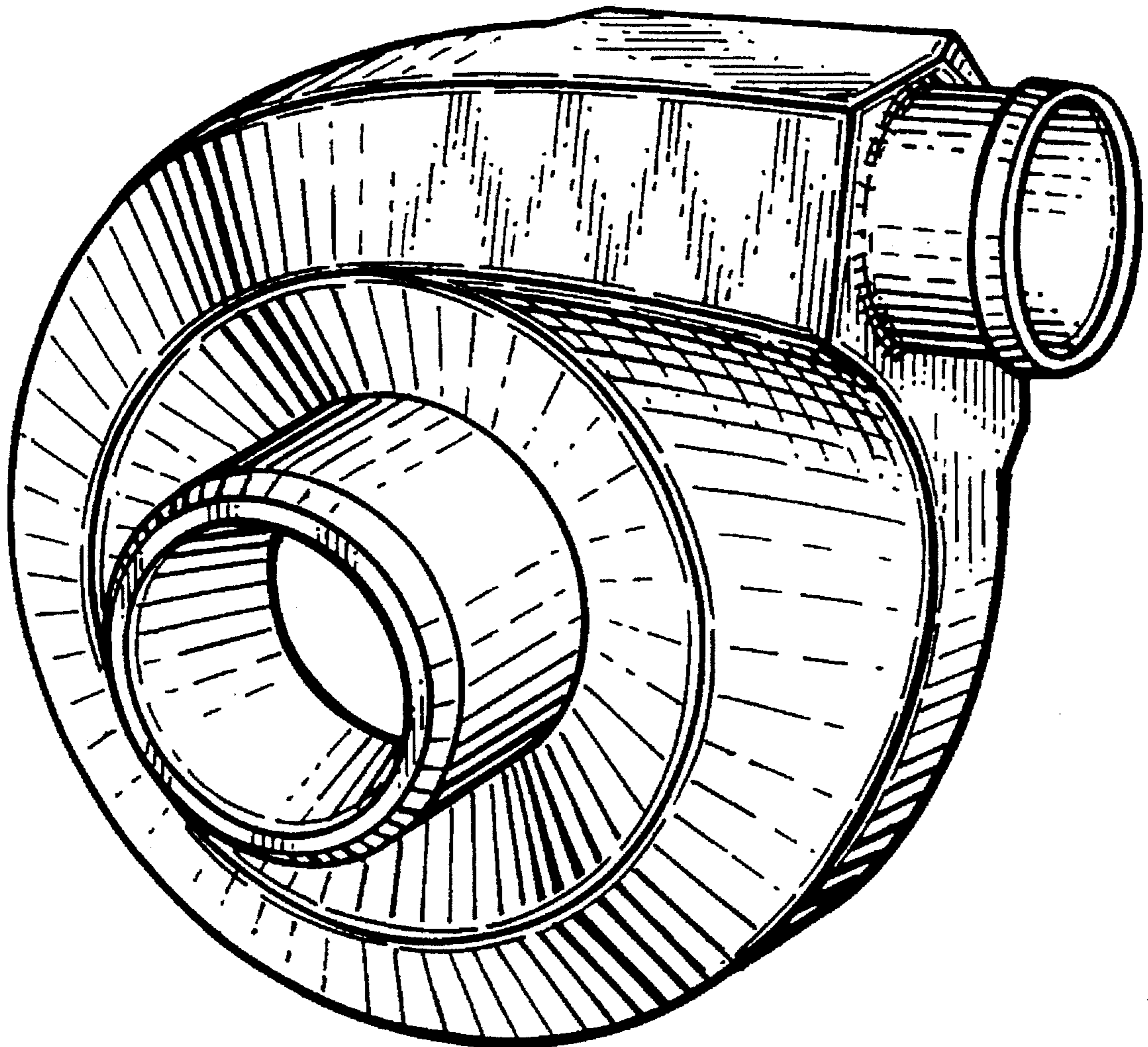

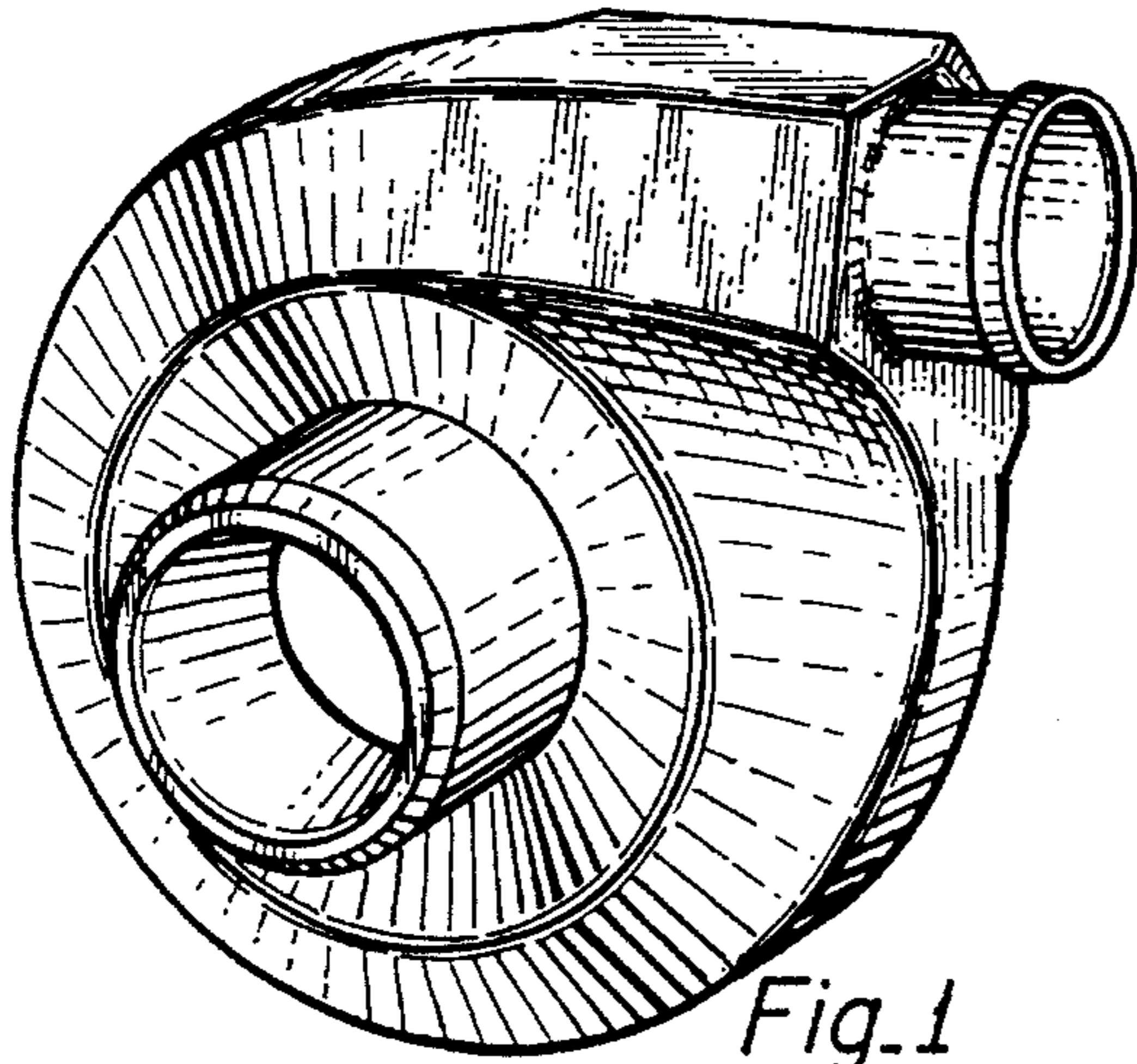

Fig. 1

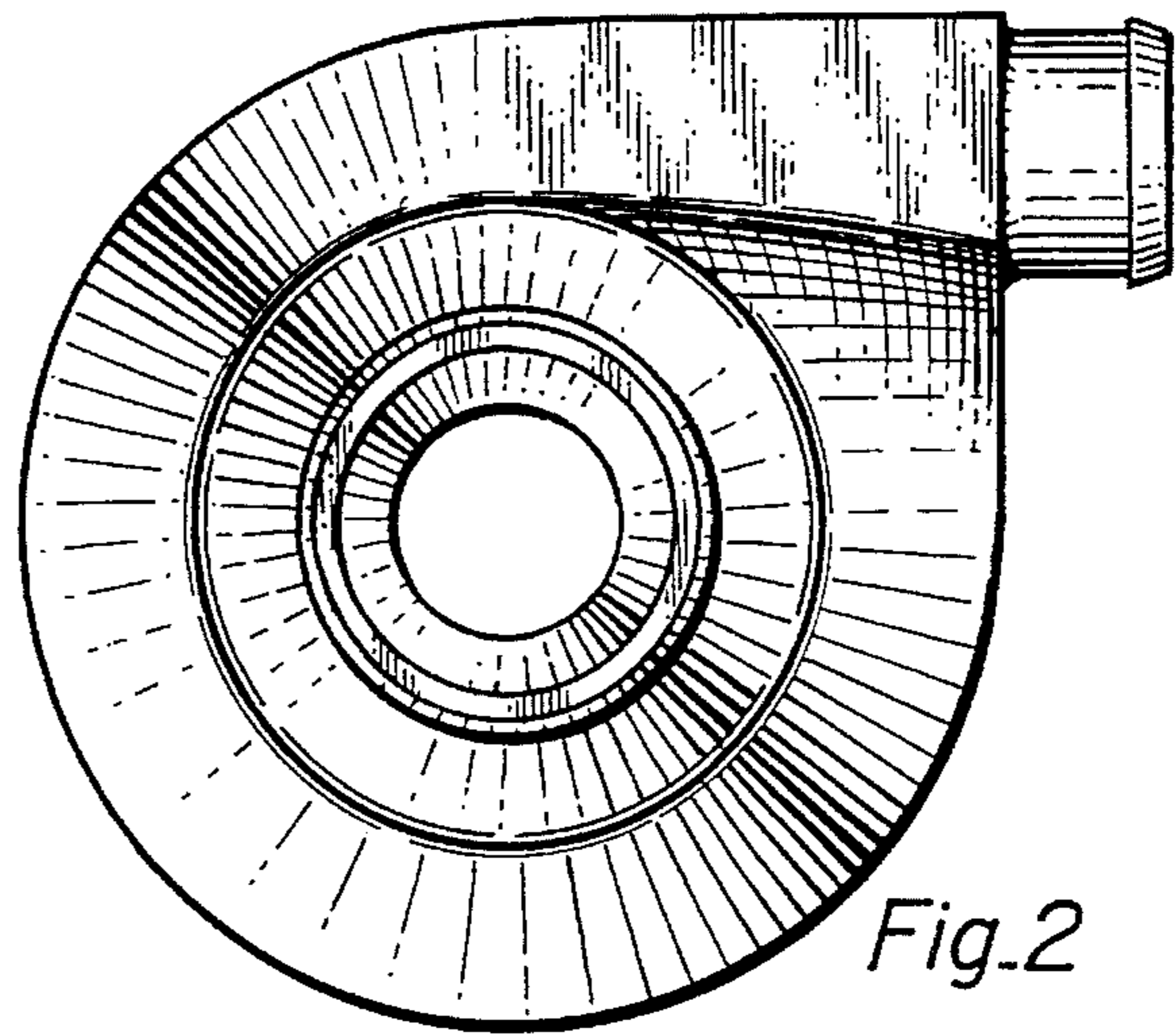

Fig. 2

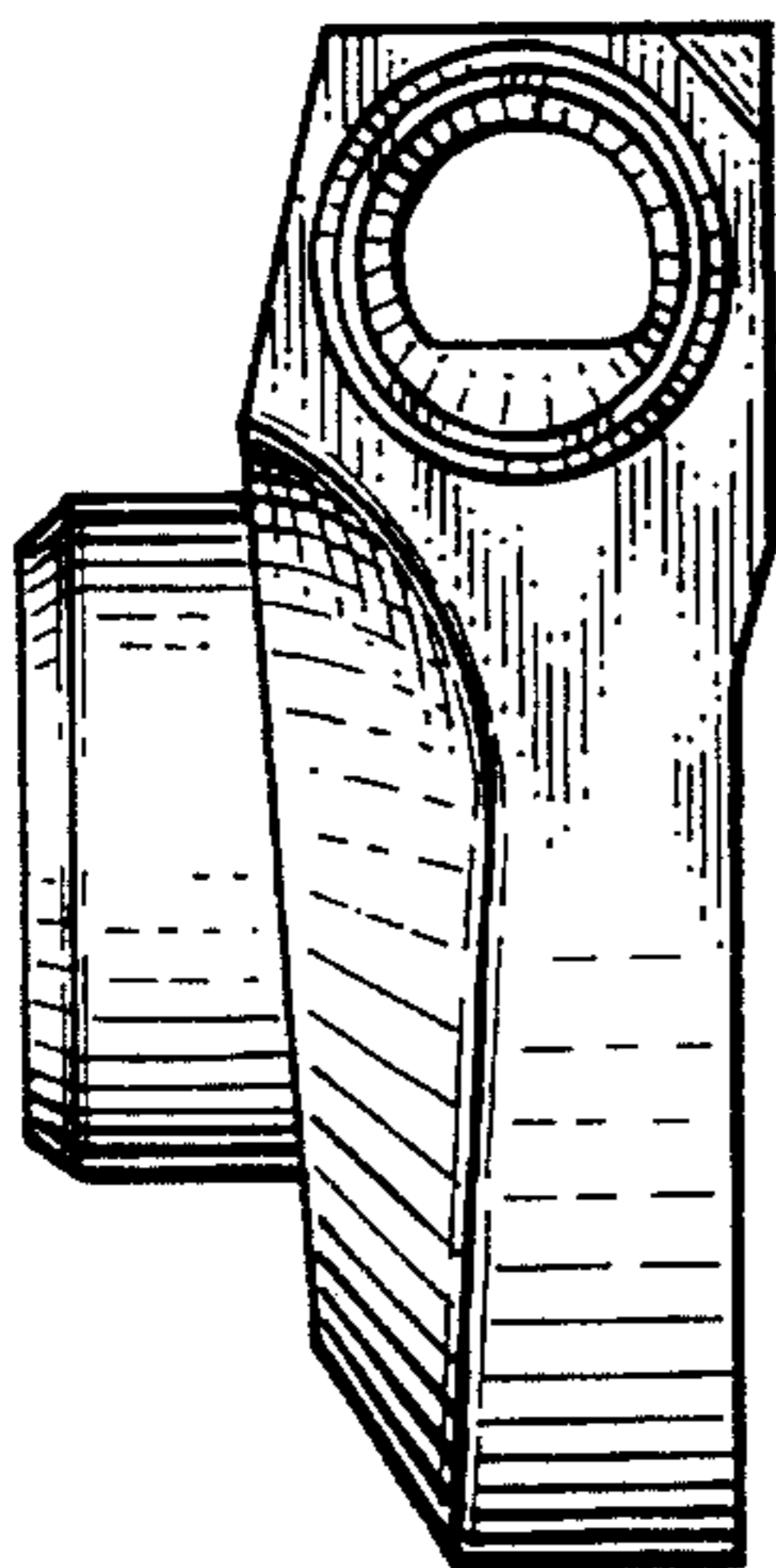

Fig. 3

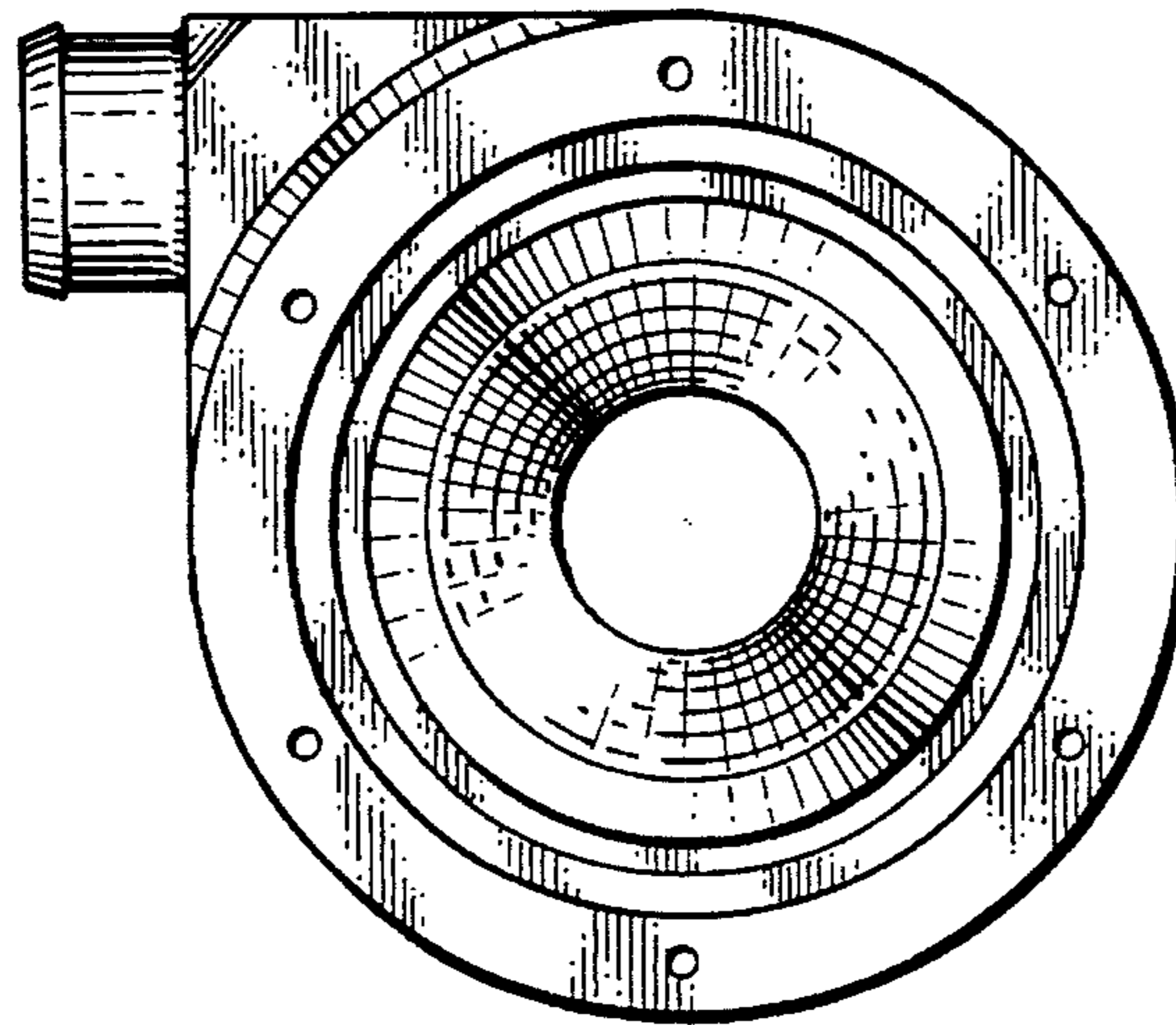

Fig. 4

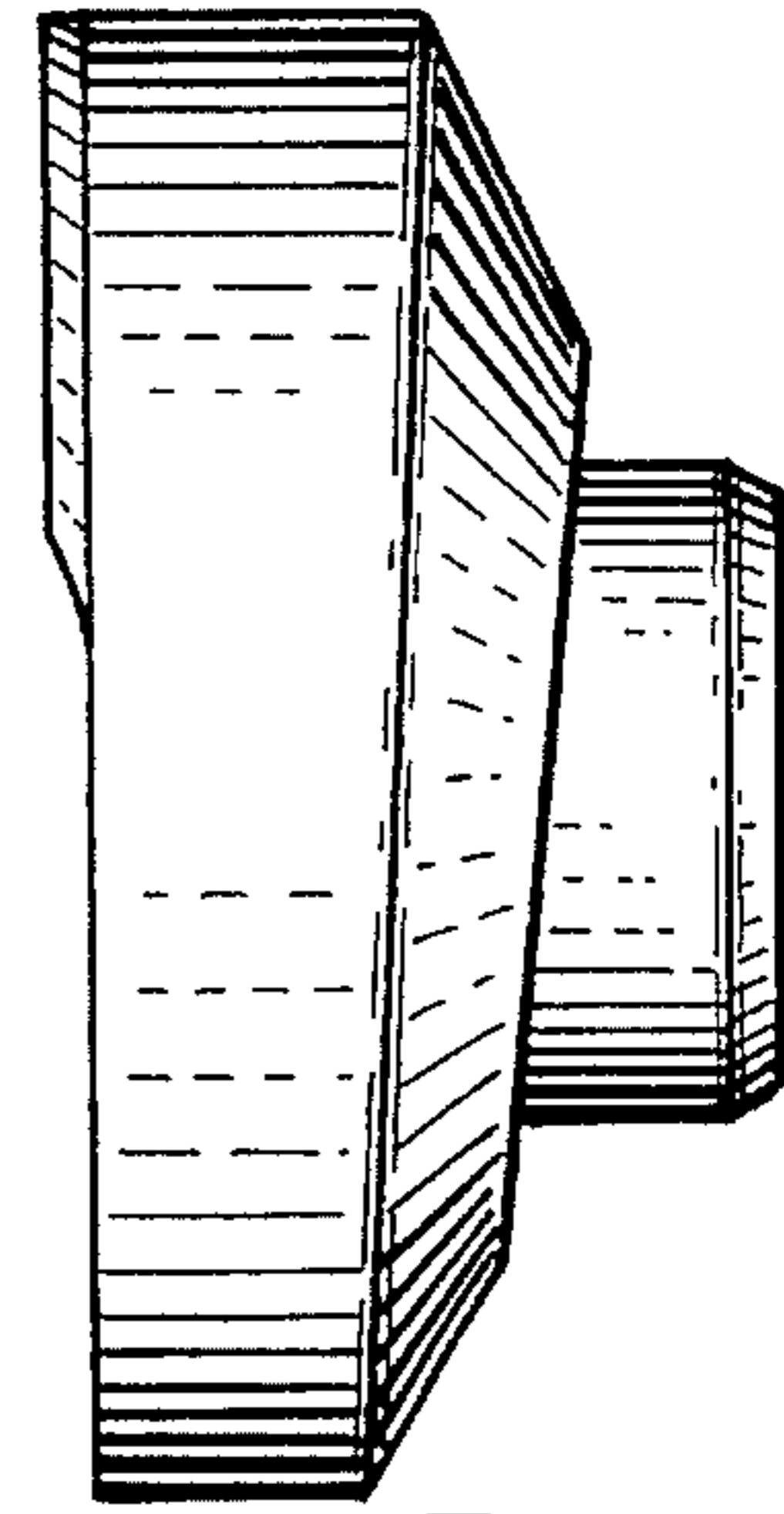

Fig. 5

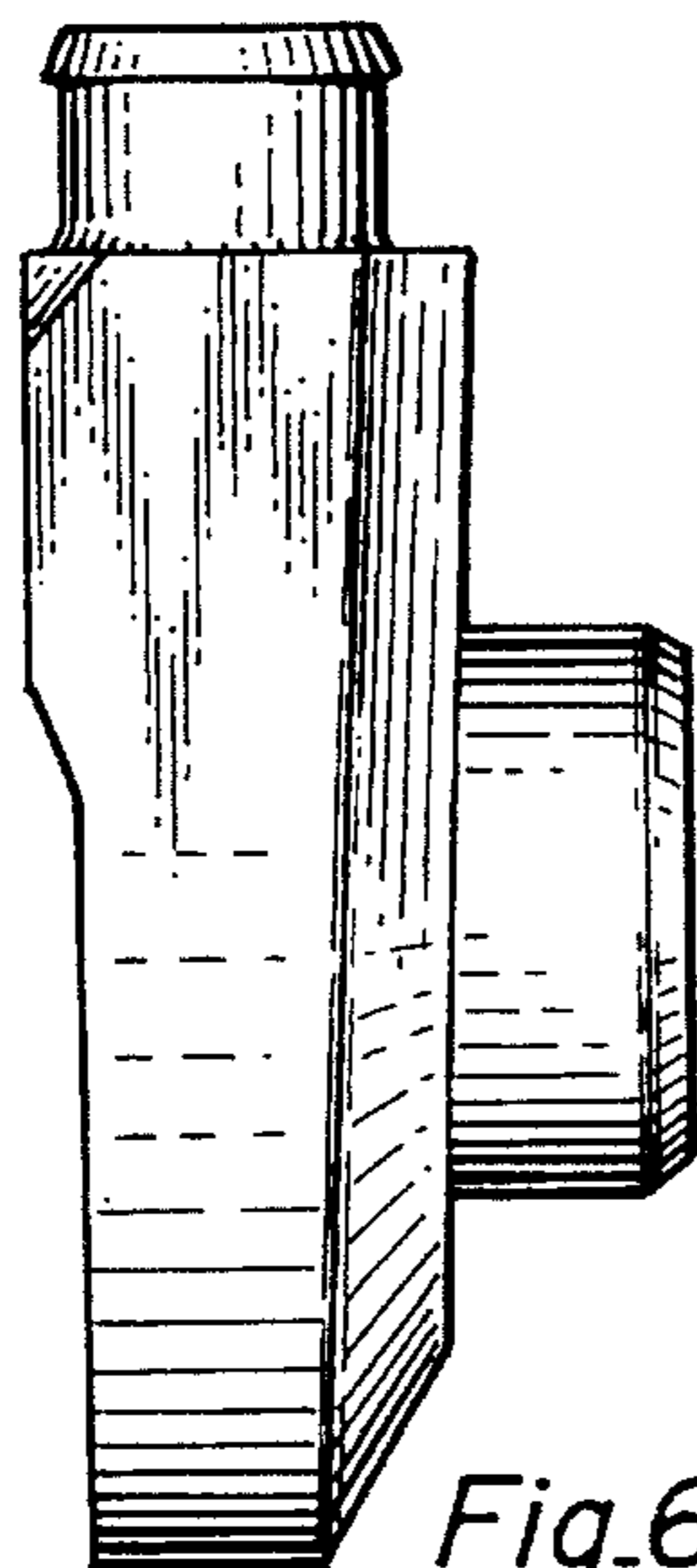

Fig. 6

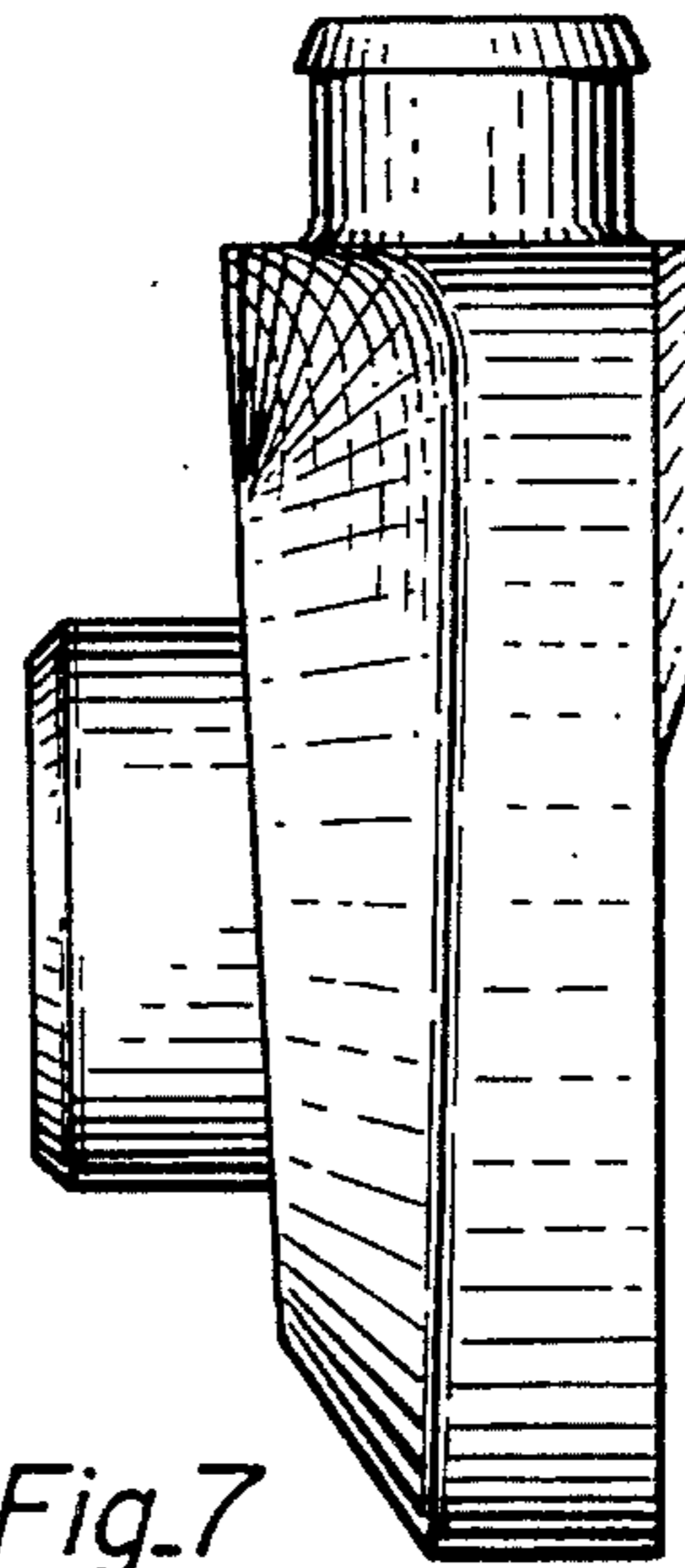

Fig. 7