



US00D368240S

# United States Patent [19] Pekkari

[11] Patent Number: **Des. 368,240**

[45] Date of Patent: **\*\*Mar. 26, 1996**

[54] **SCOOTER SLEIGH**

[75] Inventor: **Stefan Pekkari**, Umea, Sweden

[73] Assignee: **Bengt Ingvar Jacobsson**, Ursviken, Sweden

[\*\*] Term: **14 Years**

[21] Appl. No.: **15,976**

[22] Filed: **Dec. 3, 1993**

[30] **Foreign Application Priority Data**

Jun. 3, 1993 [SE] Sweden ..... 93-1316

[52] U.S. Cl. .... **D12/6**

[58] Field of Search ..... D12/6, 11; 280/12, 280/762; 180/180-184

[56] **References Cited**

**U.S. PATENT DOCUMENTS**

3,136,378	6/1964	Patee .....	180/192
3,599,740	8/1971	Martinmass .....	180/182
3,603,419	9/1971	Riddle .....	180/182

3,622,175	11/1971	Benz .....	180/182
3,877,533	4/1975	Maziarka et al. ....	180/182
4,249,626	2/1981	Fields et al. ....	180/182
4,285,529	8/1981	Vaillancourt .....	280/19.1
5,014,805	5/1991	Uchida .....	180/184

*Primary Examiner*—A Hugo Word  
*Assistant Examiner*—M. Brown  
*Attorney, Agent, or Firm*—Cushman Darby & Cushman

[57] **CLAIM**

The ornamental design for a scooter sleigh, as shown and described.

**DESCRIPTION**

FIG. 1 is a perspective view of a scooter sleigh showing my new design from the front, top and left side; FIG. 2 is a right side elevational view thereof, the left side being a mirror image thereof; FIG. 3 is a top plan view thereof; FIG. 4 is a bottom plan view thereof; FIG. 5 is a front elevational view thereof; and, FIG. 6 is a rear elevational view thereof.

**1 Claim, 4 Drawing Sheets**

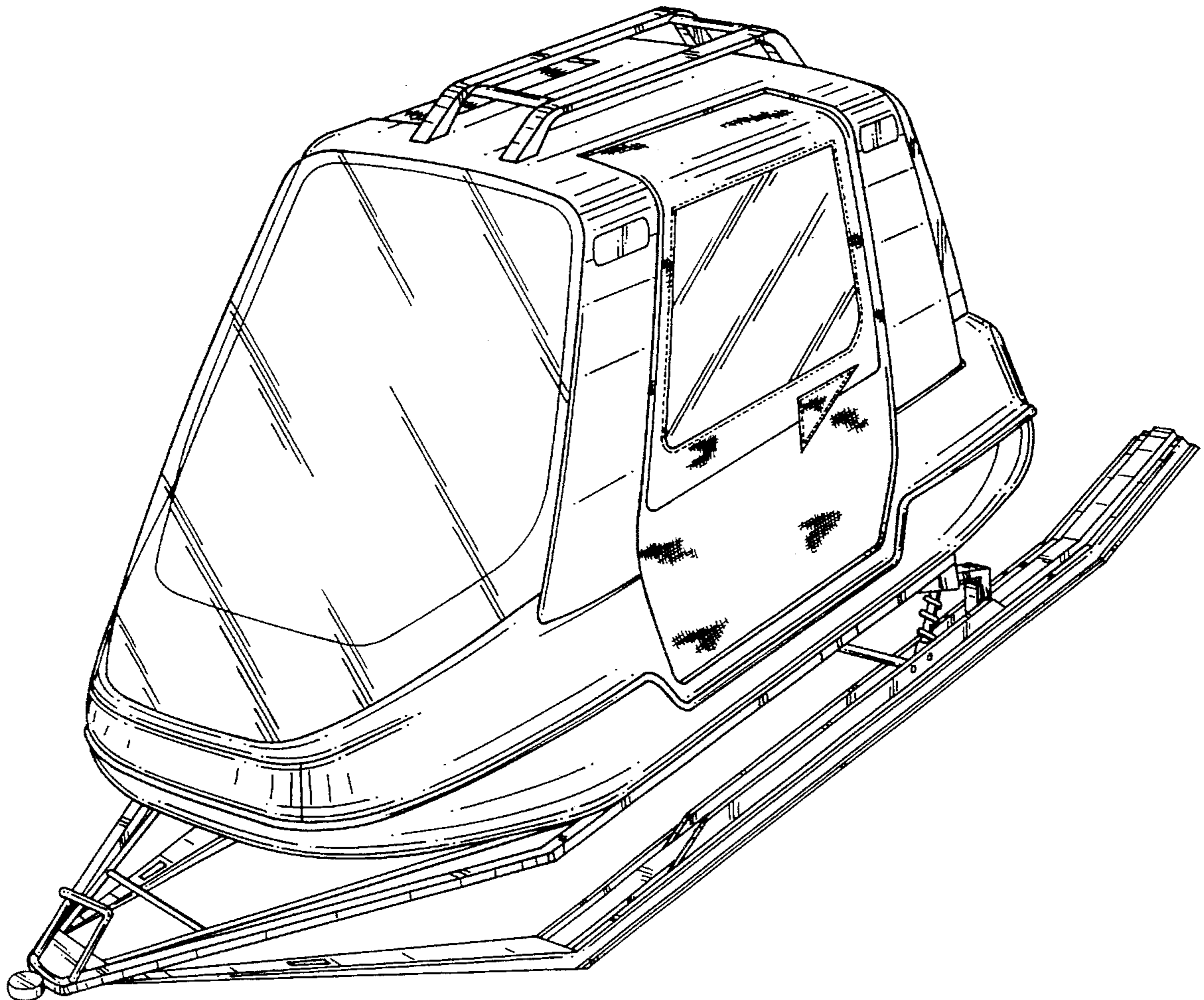

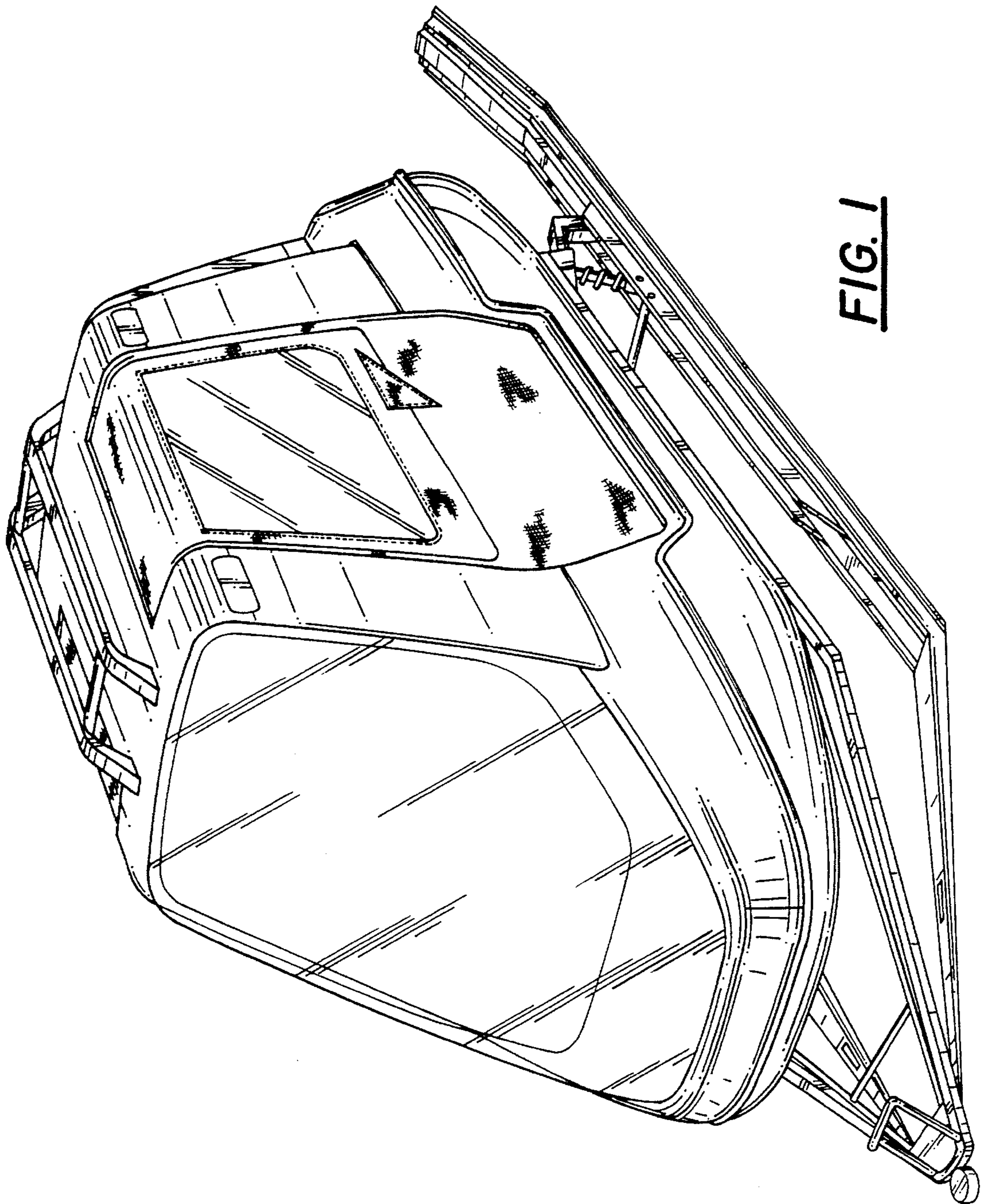
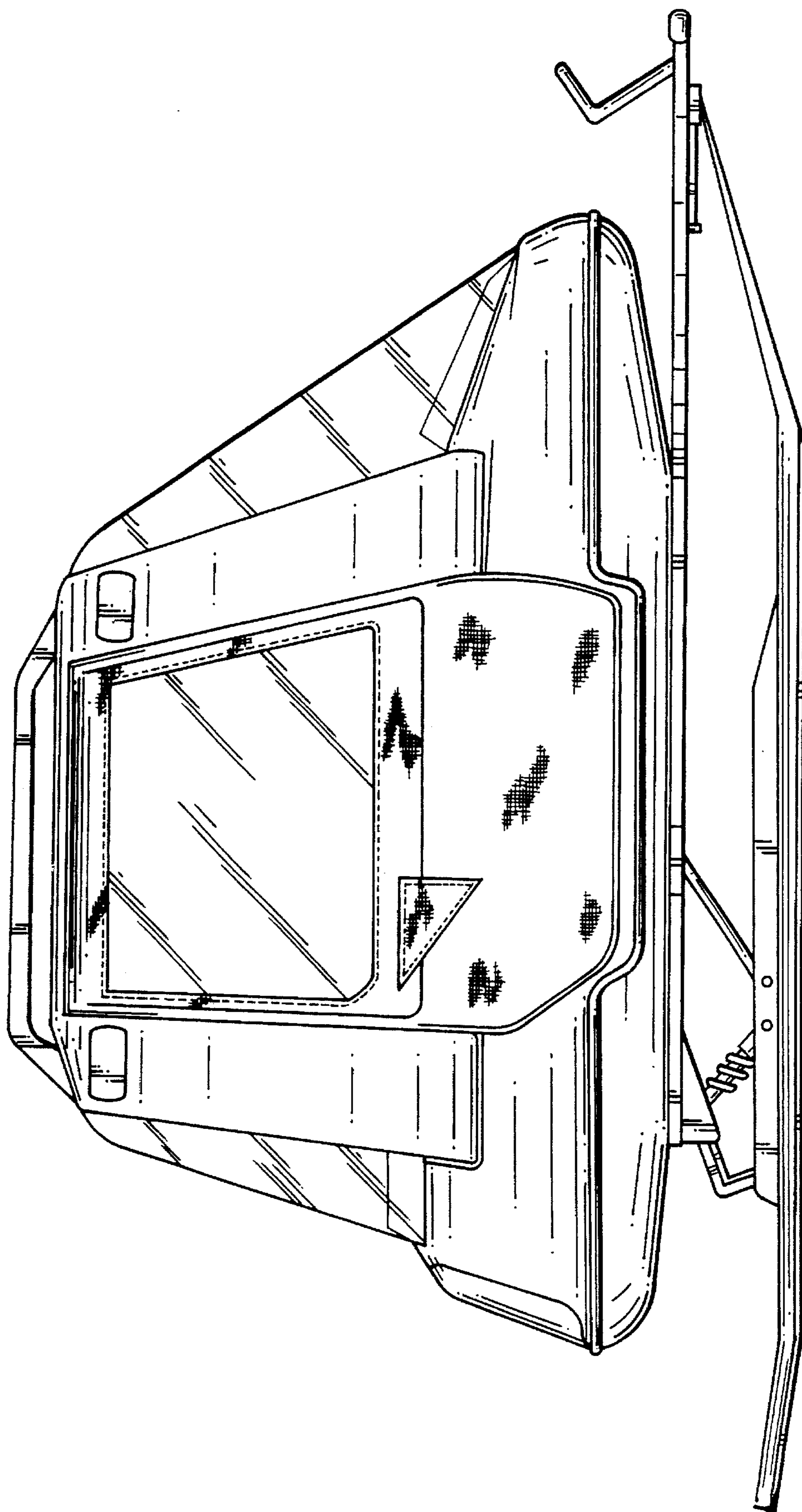
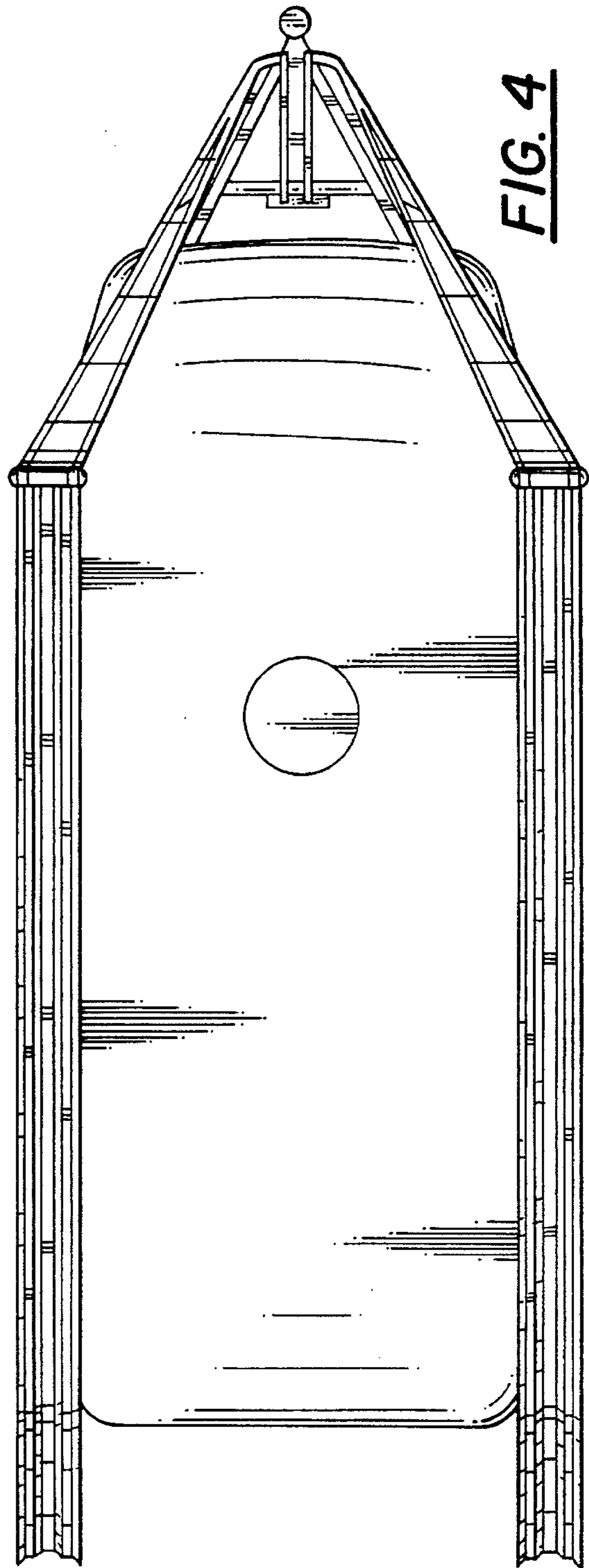
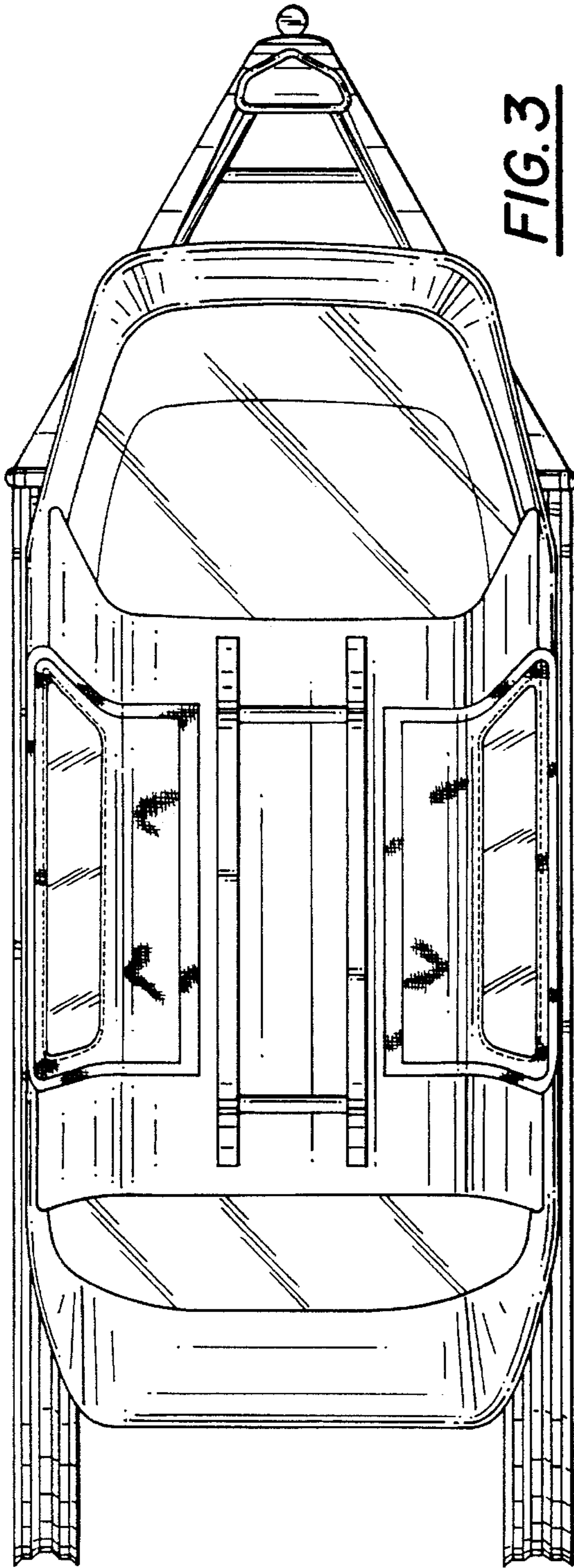

FIG. 1



**FIG. 2**



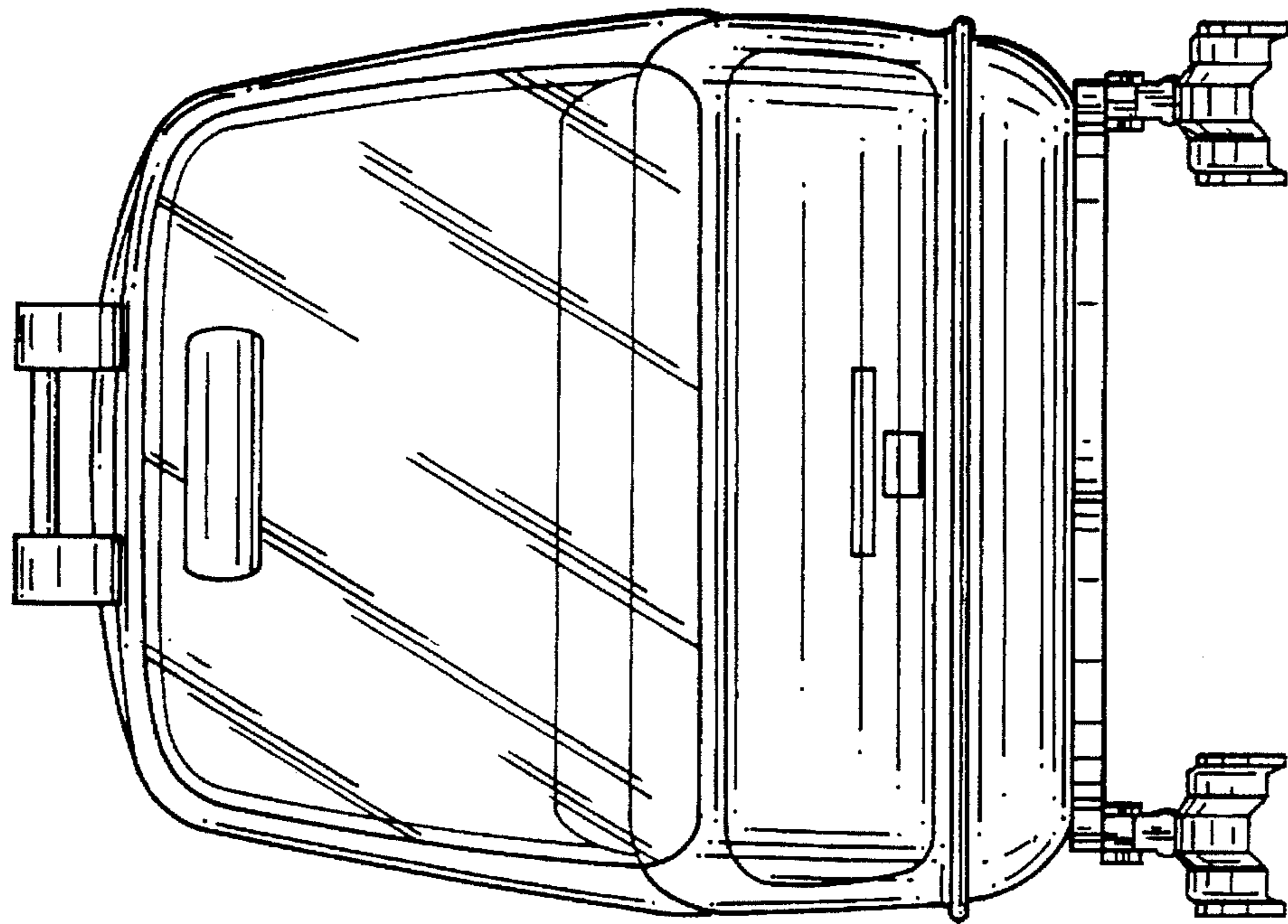

FIG. 5

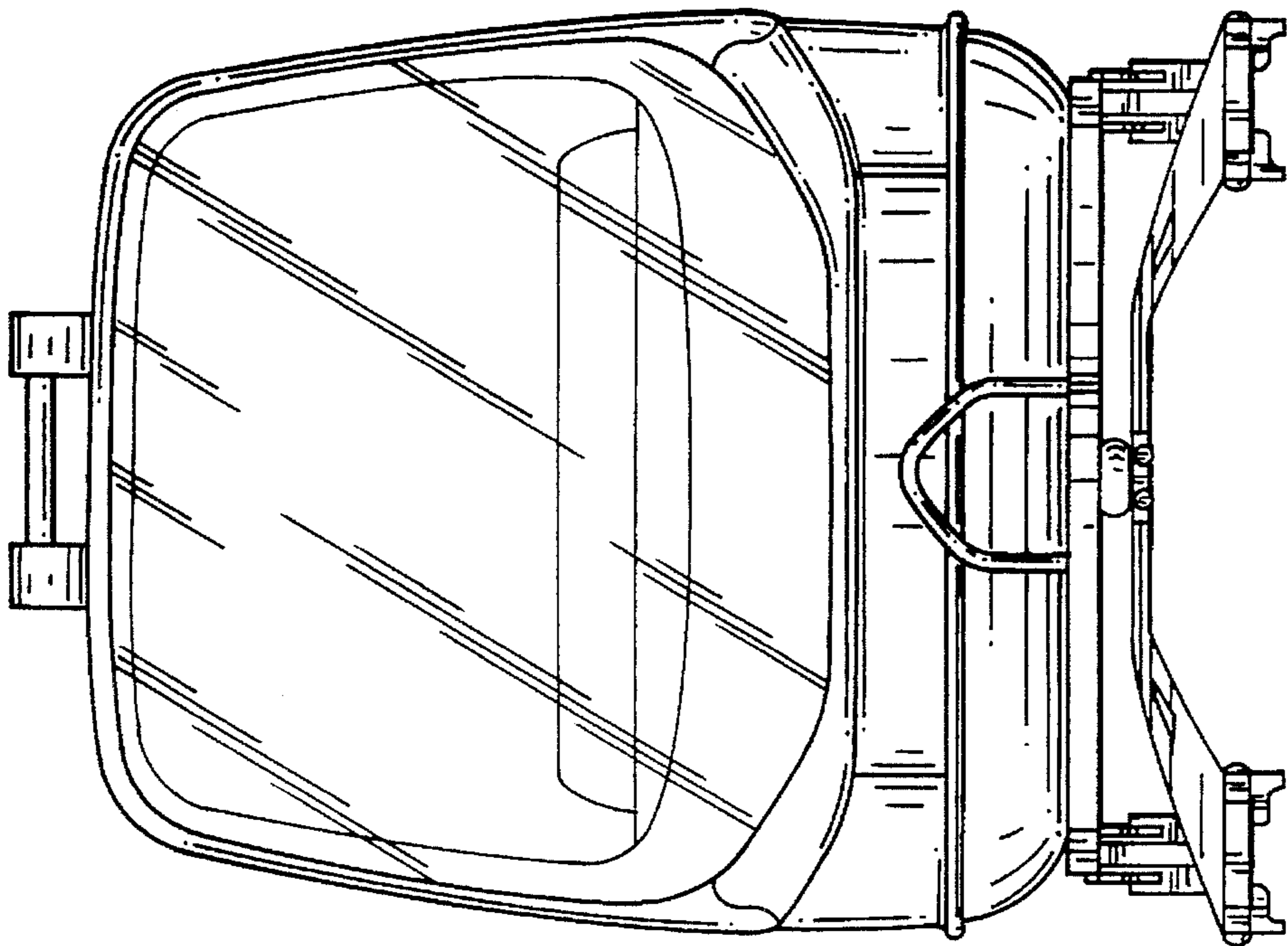

FIG. 6