



US00D368059S

United States Patent [19] Barth

[11] Patent Number: **Des. 368,059**
[45] Date of Patent: ****Mar. 19, 1996**

[54] **TRAILER HITCH GUARD**

5,378,008 1/1995 McCrossen 280/507

[76] Inventor: **Robert K. Barth**, 11763 82nd Ter. N.,
Seminole, Fla. 34642

Primary Examiner—Alan P. Douglas
Assistant Examiner—Cathron B. Matta
Attorney, Agent, or Firm—Herbert W. Larson; James E. Larson

[**] Term: **14 Years**

[21] Appl. No.: **33,238**

[57] **CLAIM**

[22] Filed: **Jan. 6, 1995**

The ornamental design for a trailer hitch guard, as shown and described.

[52] U.S. Cl. **D12/162**

[58] Field of Search D12/162; D8/349,
D8/354, 366, 373; 280/477, 507-511; 248/300;
D19/65, 99; D20/22

DESCRIPTION

[56] **References Cited**

U.S. PATENT DOCUMENTS

D. 243,166	1/1977	Jones	D12/162	X
D. 306,964	4/1990	Zupancic	D8/354	
D. 311,511	10/1990	Craig	D12/162	
D. 360,571	7/1995	Perry	D8/354	
3,522,958	8/1970	Lusignan	280/507	X
4,208,065	6/1980	Hansen	280/507	
4,226,438	10/1980	Collins	280/507	X

FIG. 1 is a perspective view of a trailer hitch guard, showing my new design;

FIG. 2 is a front view thereof;

FIG. 3 is a rear view thereof;

FIG. 4 is a left side elevational view thereof;

FIG. 5 is a right side elevational view thereof;

FIG. 6 is a top plan view thereof; and,

FIG. 7 is a bottom plan view thereof.

The broken line showing of a hitch ball is for illustrative purposes only and forms no part of the claimed design.

1 Claim, 4 Drawing Sheets

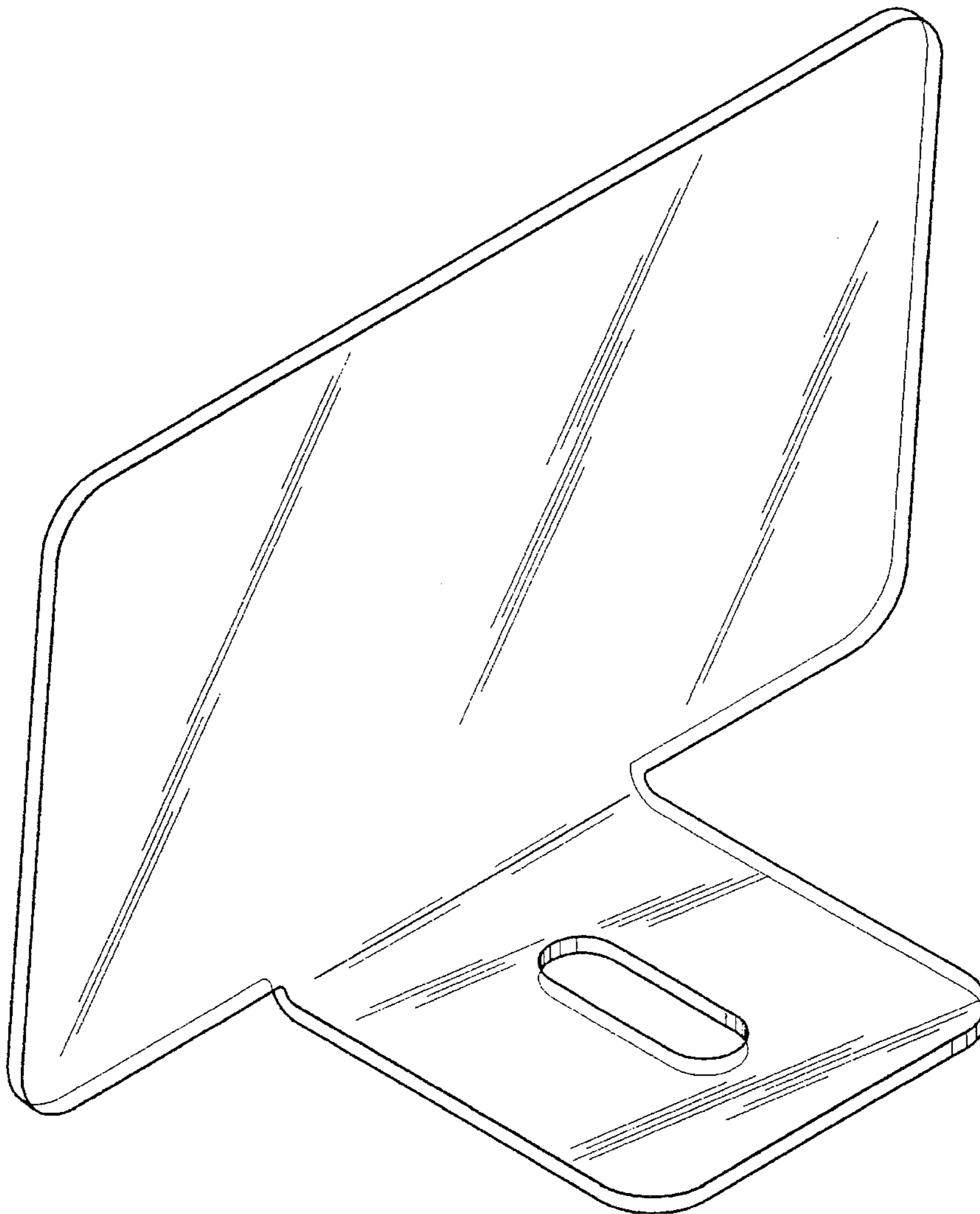

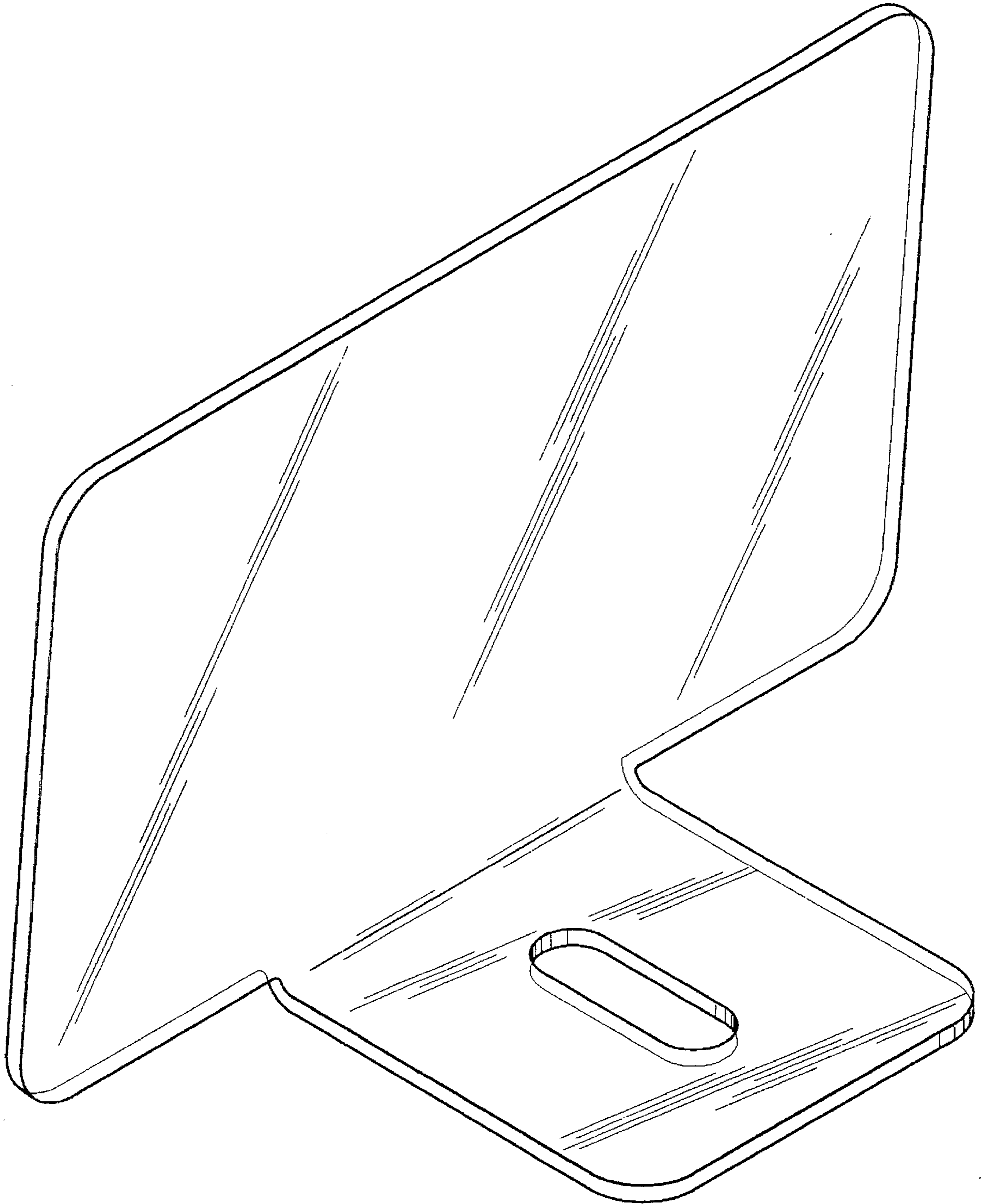

Fig. 1

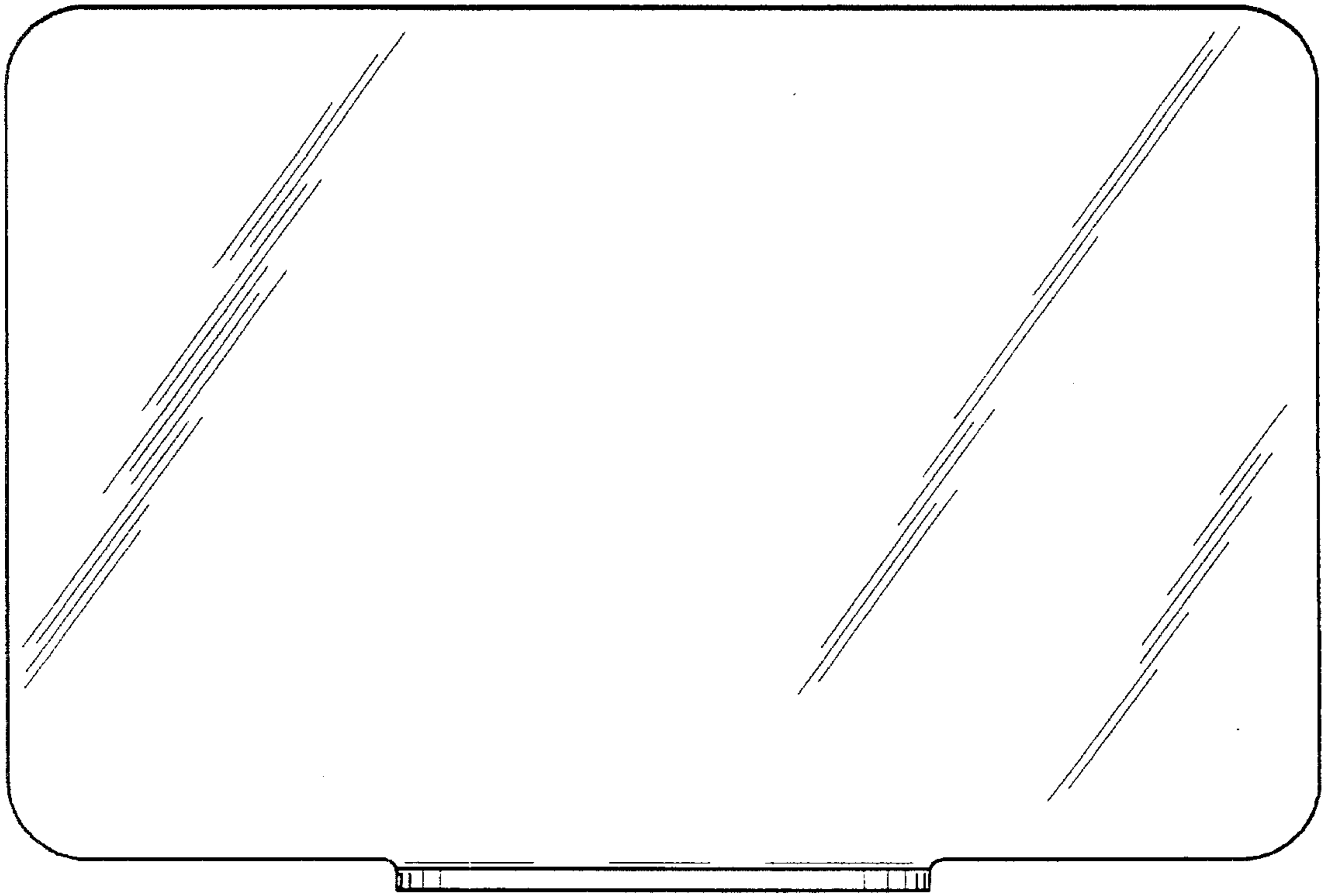

Fig. 2

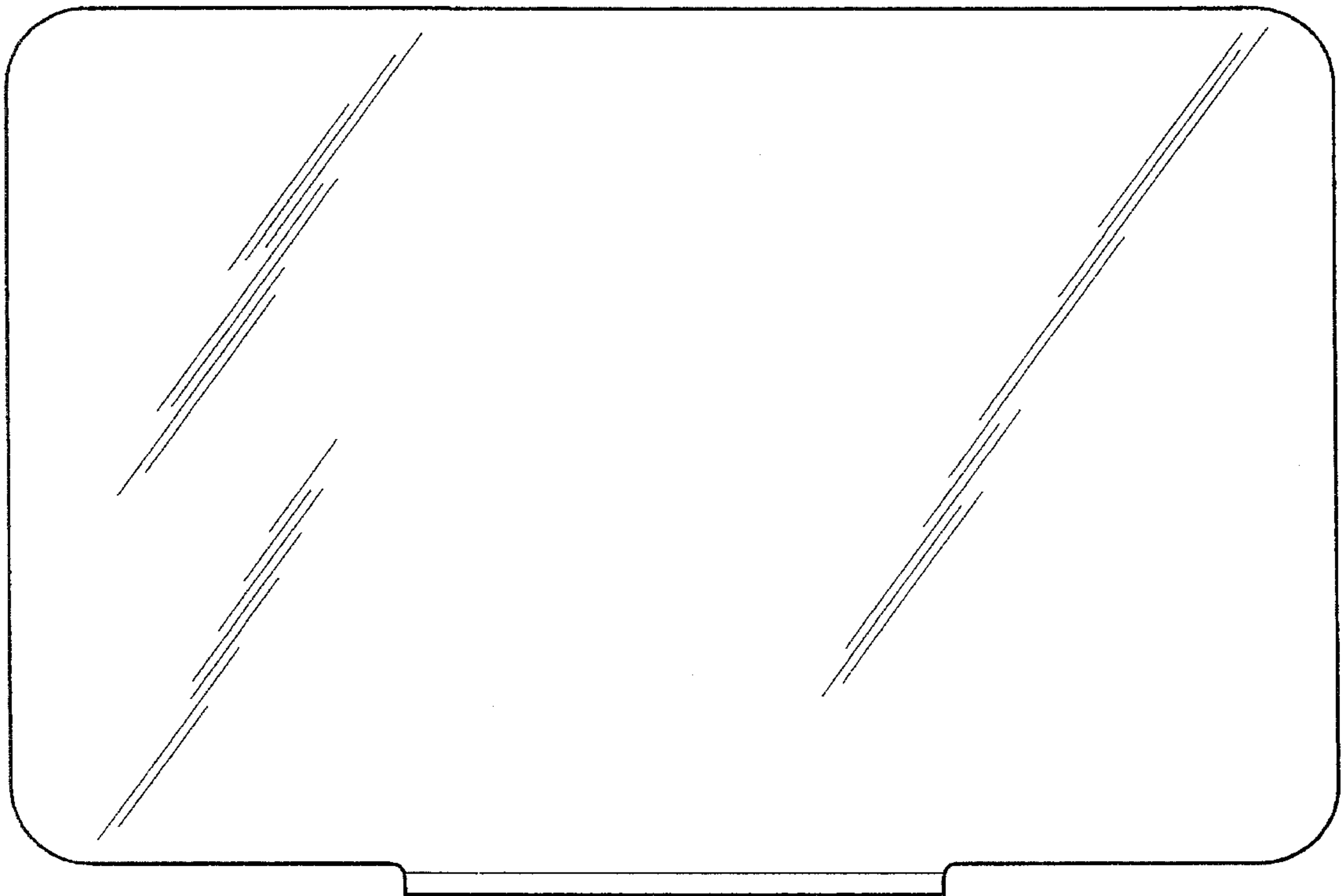

Fig. 3

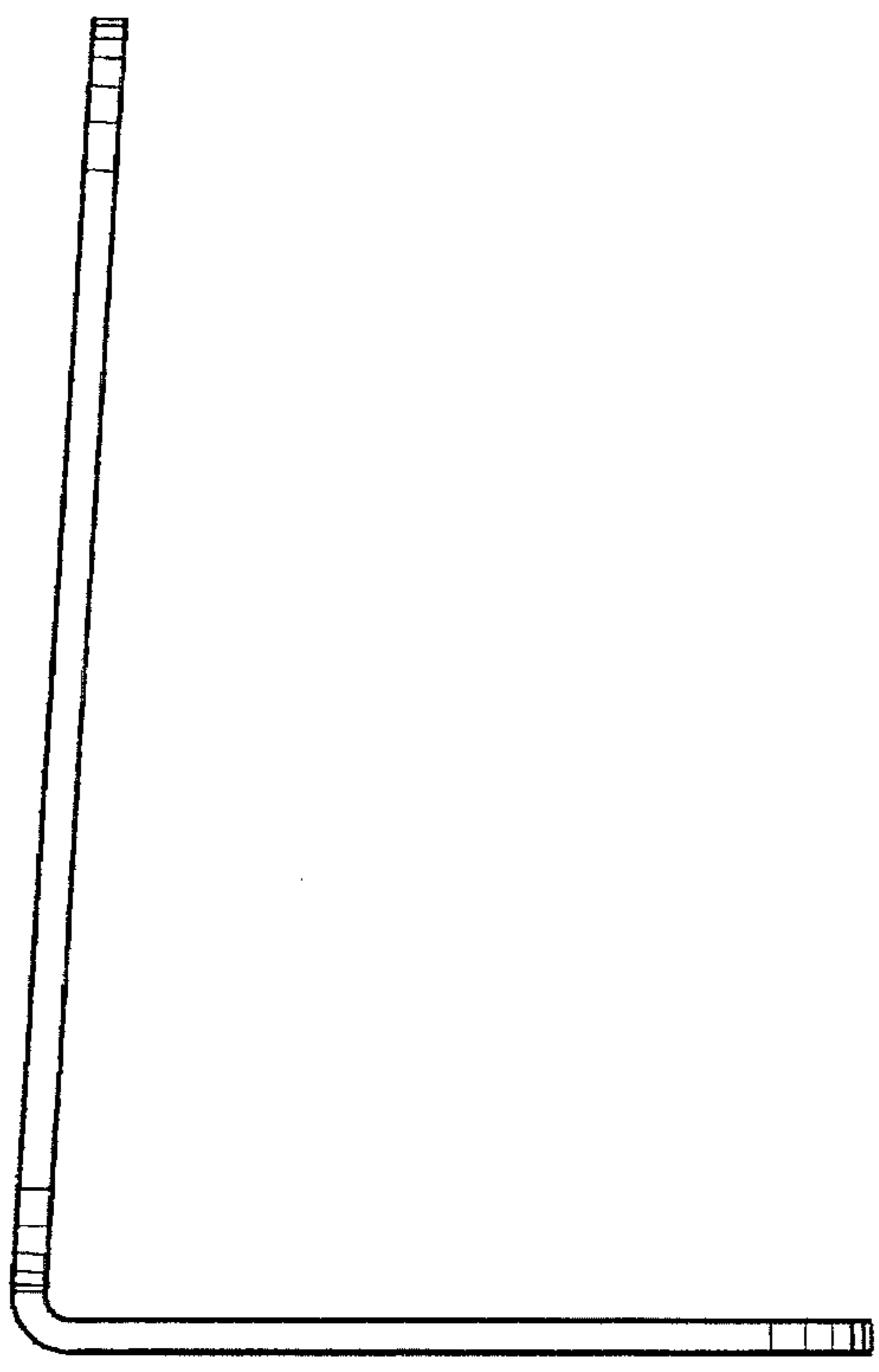

Fig. 4

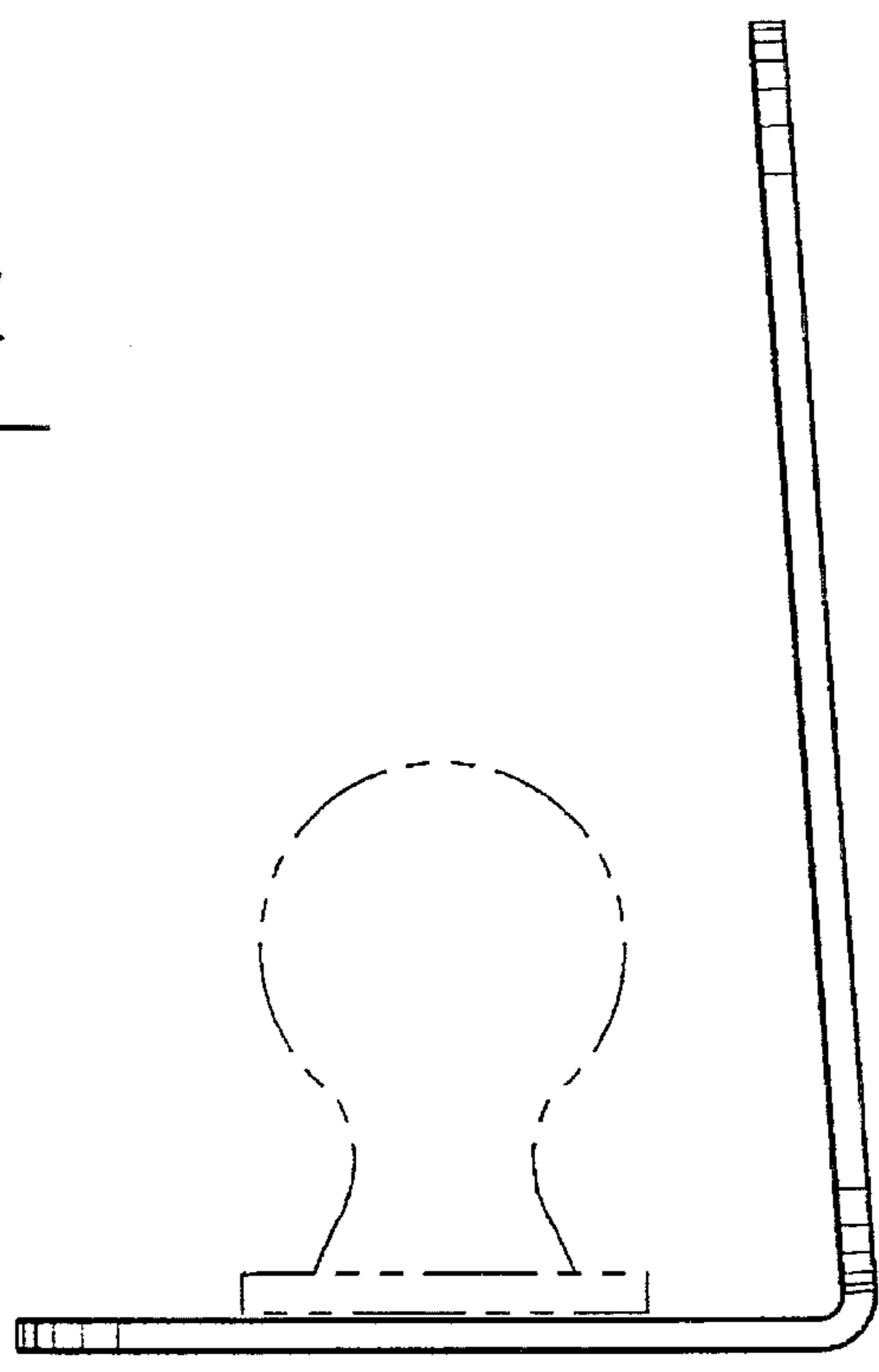

Fig. 5

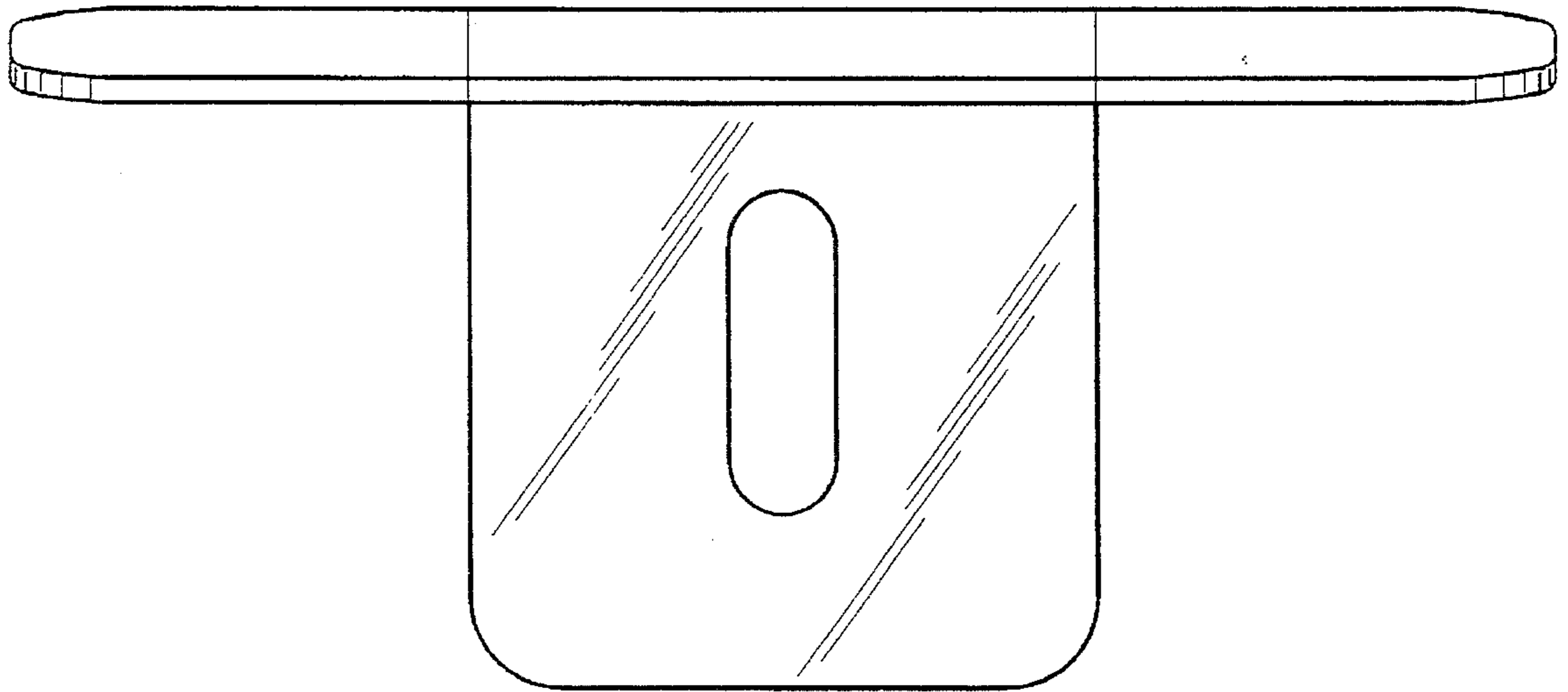

Fig. 6

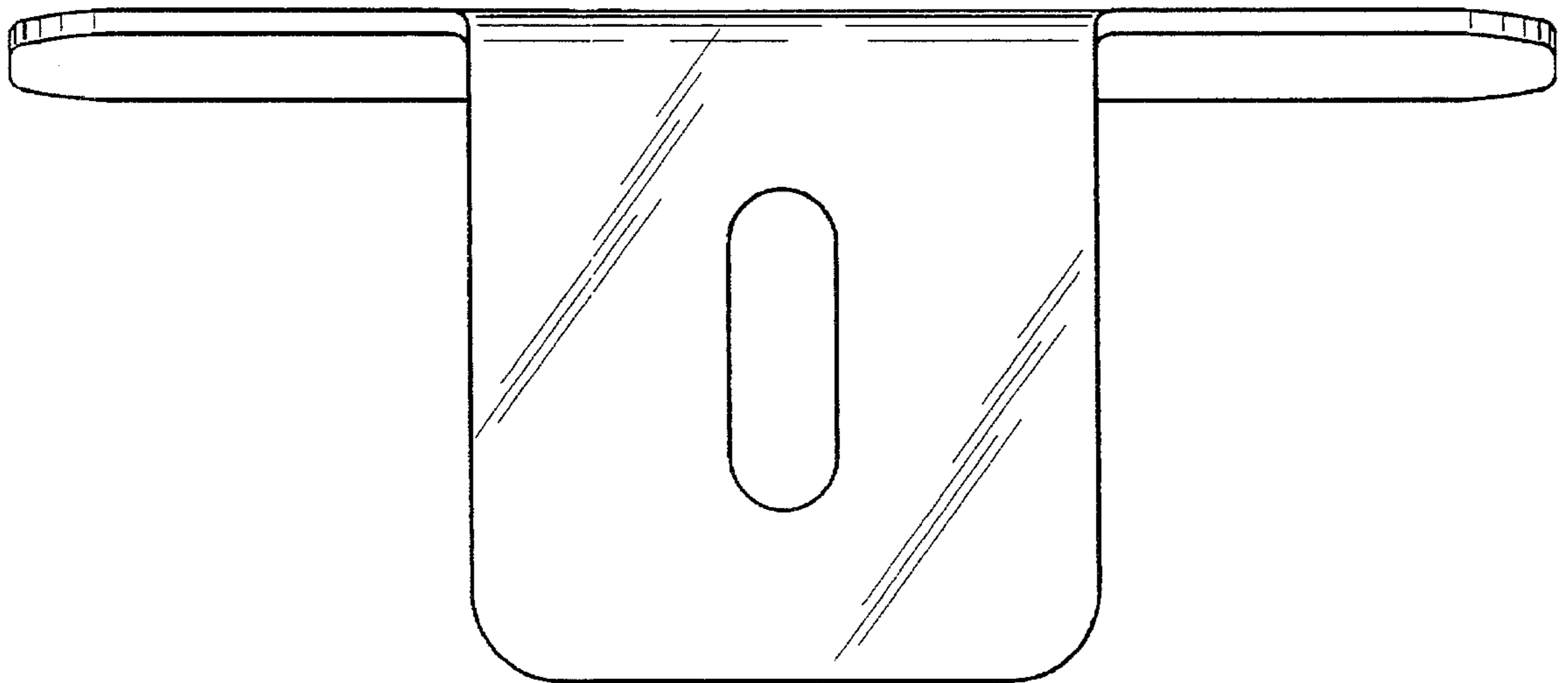

Fig. 7